

HANI™ Clamp Sensor - High Accuracy Non-Invasive Clamp Temperature Sensor



Hybrid temperature sensing on metal pipes integrated with Layer N connectivity

- Non-invasive temperature measurement
- Measure the fluid temperature inside of a metal pipe
- Accuracy for Metal Pipes:
 - Sanitary: $\pm 0.5^{\circ}\text{C}$
 - Industrial: ± 0.5 to $\pm 1.0^{\circ}\text{C}$
- Response time¹ = 5 sec (t63) / 10 sec (t90)
- 4 to 20 mA loop powered analog output
- 0 to 100°C process temperature range
- Available for 1 to 4.0" pipe diameters
- Omega Smart Core enabled
 - Data logging
 - Plug and play device detection
- IP65 environmental rating
- Patent pending



Ease of Installation

Install your HANI™ Clamp Sensor in seconds

Omega's innovative clamp-on design makes sensor installation easy. Unlike invasive sensors, HANI™ Clamp Sensors mounts to the outside of a metal pipe and measures the temperature of the process media inside the pipe.

- No drilling
- No welding
- No downtime

Need to relocate the sensor?
Un-clamp and go!

Non-Invasive & Non-Contact Operation

No penetration, no risk of contamination

The HANI™ Clamp Sensor never comes into contact with the process media flowing through the pipe. There is no risk of buildup, sensor wear or breakage from high flow rates, corrosive/abrasive liquids, wake frequency and water hammer.

High Accuracy & Fast Response Times

Performs like an invasive sensor

Omega's patent pending *Hybrid Temperature Sensing* platform uses

multiple sensors and a proprietary algorithm to achieve the same accuracy and fast response times as state-of-the-art invasive sensors without the cost and risk.

Common Applications

New and retrofitting existing systems

Lower the total cost of ownership and reduce contamination risk without sacrificing performance by upgrading to a HANI™ Clamp Sensor.

Quality control & ad-hoc sensing

Clamp-on the sensor in seconds and connect to your laptop or PC for readings anytime - anywhere.

Verify existing invasive sensors

With accuracies comparable to most state-of-the-art invasive sensors, the HANI™ Clamp Sensor can easily be placed next to an invasive sensor to verify the accuracy or determine the drift of

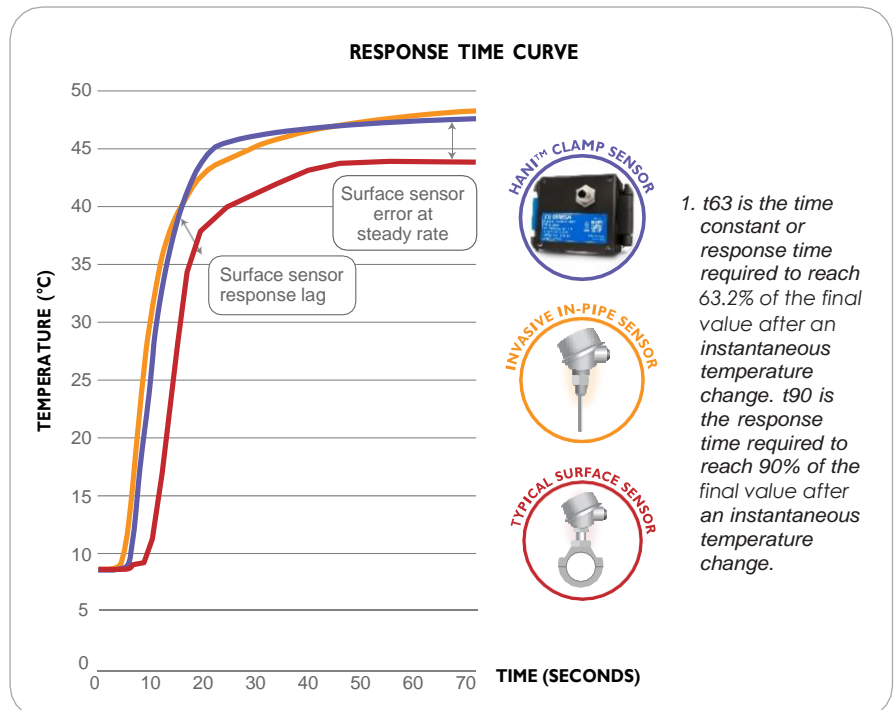

Specifications

Input Power

Voltage: 8 V_{DC} - 28 V_{DC} (loop powered)

Max Loop Resistance: R_{max} (Ω) =

$(V_{\text{supply}} - 8V) / 0.024 \text{ A}$

Analog Output

Current: 4 to 20 mA

Process Parameters

Process Medium: Water, water-based fluids (others upon request)

Materials: Metal pipes (others upon request)

Pipe Diameters:

Sanitary: 1.5", 2", 2.5", 3", 4"

Industrial: 1", 2", 2.5", 3", 4" nominal (others upon request)

Process Temperature Range:

0 to 100°C liquid, user scalable analog output

Performance

Accuracy with fluid flowing:

Sanitary Metal Pipes: ±0.5°C

Industrial Metal Pipes ±1.0°C from factory and improved accuracy to ±0.5°C possible with in-situation 1 or 2-point calibration

Response Time (t₆₃): 5 seconds

Response Time (t₉₀): 10 seconds

Environmental

Ambient Operating Temperature:

0 to 40°C (32 to 104°F)

Rating: IP65 when mated

Mechanical

Dimensions:

60.3 W x 64.31 L x 51.54 mm H

(2.38 W x 2.53 L x 2.03" H)

Materials: PA12, silicone rubber, nickel-plated brass, stainless steel

General

Agency Approvals: CE

Smart Core Enabled

Smart Core is integral to all Layer N integrated Smart Sensing devices. In addition to allowing for modular integration using any Layer N Smart Interface, this powerful suite of advanced features enables alarms and notifications, data assurance, data logging, storage, wireless connectivity and SYNC configuration.

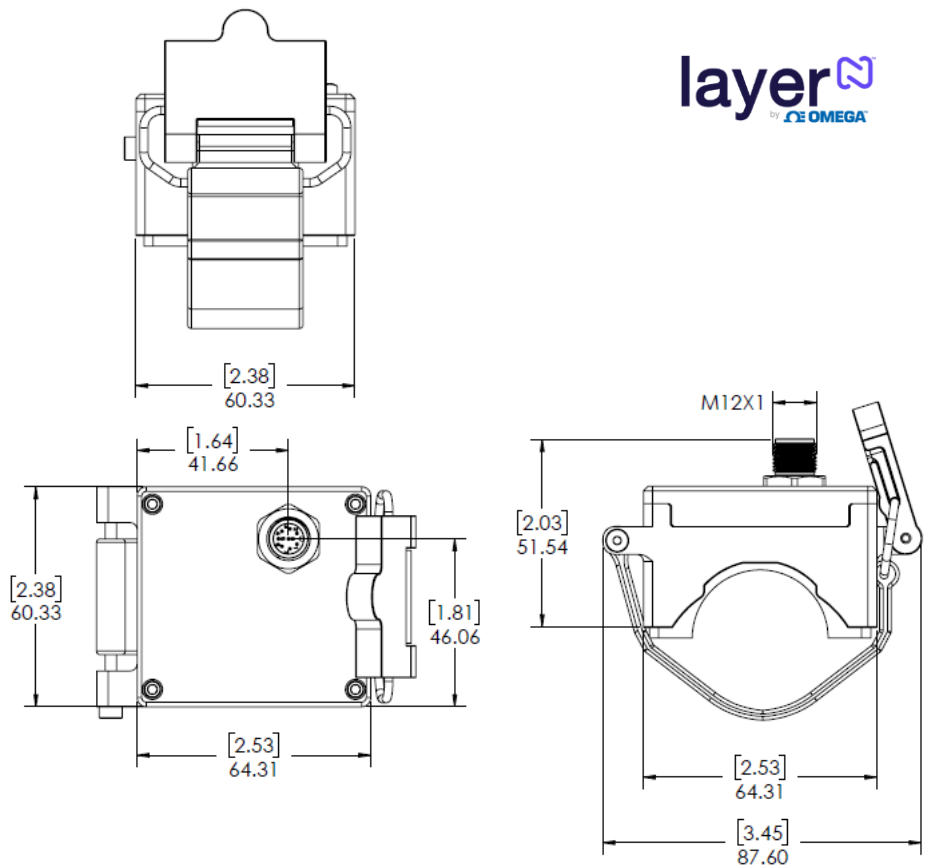

Frequently Asked Questions

How can a clamp-on temperature (surface) sensor have response times and accuracy similar to an immersion sensor?

Omega's innovative HANI™ Clamp Sensor includes multiple sensors along with a proprietary algorithm to reach response times and accuracy comparable to an immersion sensor.

Will ambient temperature affect the reading of the HANI™ Clamp Sensor?

Ambient temperature will not affect the reading of the HANI™ Clamp Sensor. Operating temperature for the clamp-on sensor is 0 to 40°C (32 to 104°F).

Is there any special preparation required to properly setup and mount the HANI™ Clamp Sensor?

There is no special preparation or tools required to setup and mount the sensor, however, when setting up any sensor ensure the mounting area is clean, dry, and free from any debris.

How should the sensor be oriented on the pipe?

The sensor can be mounted on any straight pipe at least 2.5" long. It is suggested to mount the sensing surface on the bottom half of the pipe for best results.

Are other pipe diameters / sizes available?

Yes, other diameters / sizes are available. Please contact us to discuss your specific application.

How can I improve the accuracy of ±1.0°C with my industrial pipe application?

Industrial pipes have a wide variety of tolerances, surface finishes, and coatings which can affect the accuracy. An in-situation user calibration can be done to improve the accuracy for your specific application. Use the free Omega Sync software to do a 1 or 2-point calibration with the HANI™ Clamp Sensor and an in place immersion sensor. See the user manual for additional details.

Other than water-based process mediums, can other liquids and viscosities be measured?

Yes, please contact us to discuss your specific application.

M12 8-Pin Wiring

Pin	Name	Function	Wiring
Pin 1	Loop -	4 to 20 mA Return	4 to 20 mA
Pin 2	INTR	Interrupt Signal	Layer N
Pin 3	SCL	I2C Clock Signal	Layer N
Pin 4	SDA	I2C Data Signal	Layer N
Pin 5	Shield	Shield Ground	Layer N
Pin 6	Loop +	4 to 20 mA Source	4 to 20 mA
Pin 7	GND	Power Ground	Layer N
Pin 8	3.3VDD	Power Supply	Layer N

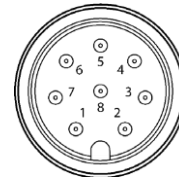

HANI™ Clamp Temperature Sensor

Model Number	Description
HANI-C-1.5S-M-MA	4 to 20 mA output, 0 to 100°C, 1.5" sanitary metal pipe
HANI-C-2.0S-M-MA	4 to 20 mA output, 0 to 100°C, 2.0" sanitary metal pipe
HANI-C-1.0I-M-MA	4 to 20 mA output, 0 to 100°C, 1.0" industrial metal pipe
HANI-C-2.0I-M-MA	4 to 20 mA output, 0 to 100°C, 2.0" industrial metal pipe
HANI-C-1.5S-M-MA-CAL-3	4 to 20 mA output, 0 to 100°C, 1.5" sanitary metal pipe, Cal Cert
HANI-C-2.0S-M-MA-CAL-3	4 to 20 mA output, 0 to 100°C, 2.0" sanitary metal pipe, Cal Cert
HANI-C-1.0I-M-MA-CAL-3	4 to 20 mA output, 0 to 100°C, 1.0" industrial metal pipe, Cal Cert
HANI-C-2.0I-M-MA-CAL-3	4 to 20 mA output, 0 to 100°C, 2.0" industrial metal pipe, Cal Cert

CAL-3 option is a 3 point calibration at 10°, 50° and 90° C. CAL-4 option is a user selected number and value of temperature points, please contact us for a quote.

Layer N Smart Interface

Layer N Smart Sensing devices require a Layer N Smart Interface to operate and connect to your Layer N Ecosystem. There are both wired and wireless options. Omega Sync software is free and enables you to read the fluid temperature digitally in just a few seconds.

Model Number	Description
IF-001	USB Smart Interface
IF-002	RS485/Modbus Smart Interface
IF-006-1-NA	Wireless Interface 915 MHZ (for North America)
IF-006-1-EU	Wireless Interface 868 MHZ (for Europe)

Accessories

Model Number	Description
M12.8-T-SPLIT	Smart Probe M12-8 pin shielded T-splitter — enables access to I/O pins
M12.8-S-F-FM	M12-8 pin female straight plug field install connector with screw terminals
DM12CAB-8-1-RA	1m (3.3') cable dual M12-8 connector, right angle terminator
DM12CAB-8-3-RA	3m (9.8') cable dual M12-8 connector, right angle terminator
DM12CAB-8-5-RA	5m (16.4') cable dual M12-8 connector, right angle terminator
DM12CAB-8-1	1m (3.3') cable dual M12-8 straight connector
DM12CAB-8-3	3m (9.8') cable dual M12-8 straight connector
DM12CAB-8-5	5m (16.4') cable dual M12-8 straight connector