

# ANGULAR PNEUMATIC GRIPPERS 180° SERIES DIRECTCONNECT™

## DCT Series

- Highly Configurable Modular Construction, Exclusive DIRECTCONNECT™ Technology
- Full Jaw Opening (180°) Allows Part to be Direct Fed into Gripper, Eliminating One Additional Motion
- Compact Design for Use in Confined Spaces
- Shielding to Repel Chips for Use in Harsh Environments
- Repeatability  $\pm 0.05$  mm (0.002") and Accuracy of  $\pm 0.07$  mm (0.0028")
- Up to 5 Million Cycles in Typical Applications and 10 Million with Maintenance
- Temperature Rating from -35 to 80°C (-30 to 180°F)
- System Requires 3 to 7 bar (40 to 100 psi) Dry Filtered (40 microns or better) Air Supply
- Accessory Equipment Required—4-Way 2-Position Pneumatic Control Valve

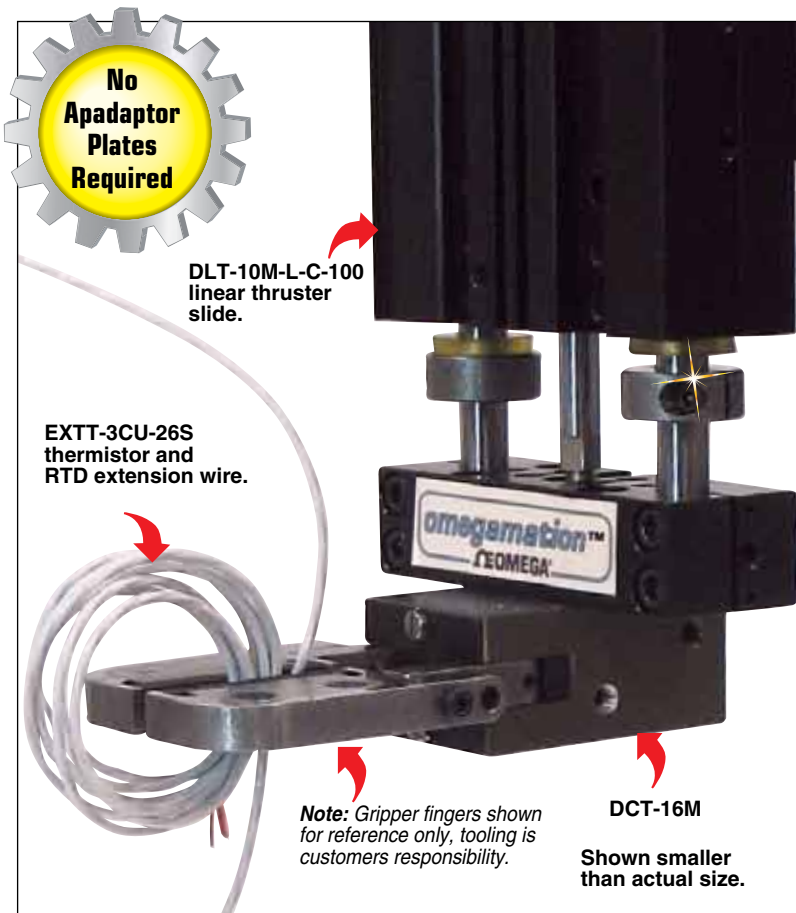

## PNEUMATIC SPECIFICATIONS IMPERIAL METRIC

**Pressure Operating Range:** 3 to 7 bar (40 to 100 psi)

**Cylinder Type:** Double acting

**Dynamic Seals:** Internally lubricated Buna-N

**Valve Required to Operate:** 4-way, 2-position

### AIR QUALITY REQUIREMENTS

**Air Filtration:** 40 Micron or better

**Air Lubrication:** Not necessary\*

**Air Humidity:** Low moisture content (dry)

### TEMPERATURE OPERATING RANGE

**Buna-N Seals (Standard):** -35 to 80°C (-30 to 180°F)

**FKM Seals (Optional):** -30 to 150°C (-20 to 300°F)

### MAINTENANCE SPECIFICATIONS

**Expected Life Normal Application:**  
5 million cycles w/preventative maintenance  
10+ million cycles\*

**Field Repairable:** Yes

**Seal Repair Kits Available:** Yes

\* Addition of lubrication will greatly increase service life.

## MOUNTING INFORMATION

### Grippers Can be Mounted and Operated in Any Orientation

Gripper is located from the top with 2 dowel pins and assembled with 2 screws.



DIRECTCONNECT mounting pattern:

Gripper is located with 2 dowel pins and assembled with 4 screws.

Alternative pattern: Gripper is located with 2 dowel pins and assembled with 2 screws.



The gripper is protected from falling debris when it is mounted and operated upside down.

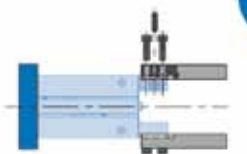

Fingers are centered over the jaws, located with 1 dowel pin and assembled with 2 screws.



Gripper can be operated utilizing top manifold air ports.

# PRODUCT FEATURES

## Gripper Attachment

Gripper mounting from side or bottom

## FKM Seals

FKM seals for high temperatures -30 to 150°C (-20 to 300°F) are optional

## Quality Components

Made from aluminum alloy anodized with PTFE impregnation. The gripper's main components are made of heat treated steel.

## Inductive Sensor Mounting Kit

Accessory (SD) in order to sense jaw position. Comes with 2 holders for tubular sensors and 2 adjustable flags (except size -12).

## Magneto Resistive Sensor Mounting Kit

Standard mounting slots for magneto resistive sensors. (sensors sold separately)

## Adjustable Stop

Accessory (BR) in order to adjust the opening of jaws, between 0° to 180°

## Shielded Plate and Wiper Covers

Gripper body is shielded to repel chips and other particulate from internal drive mechanism

## DIRECTCONNECT™ Mounting Patterns

DIRECTCONNECT™ mounting surface on back of body (sizes 12 to 20)

## Multiple Air Ports

Side or top air ports (top ports require O-ring)

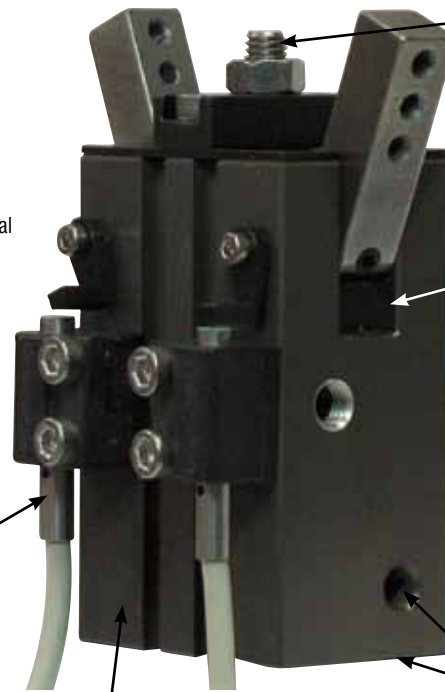

# OPERATING PRINCIPLE

- A Double Acting Piston, with a Ring Magnet for Magneto Resistive Sensing, is Connected to a Fork Driver on which 2 Drive Pins are Fixed
- Jaw Rotation is Synchronized with the Drive Pin-Jaw Assembly
- Sliding in These Slots, Drive Pins Convert Vertical Motion of the Piston into Rotating Opposite Synchronous Motion of Both Jaws
- Each Jaw Has a Useful Rotation Stroke of 90°, Between the 90° Open Position and the 0° Gripping Position, Plus a Gripping Over-Stroke of Approximately 1.5° Before Reaching the Fully Gripped Position; Jaws Have to be Designed for a 0° Gripping Position (Parallel Jaws)

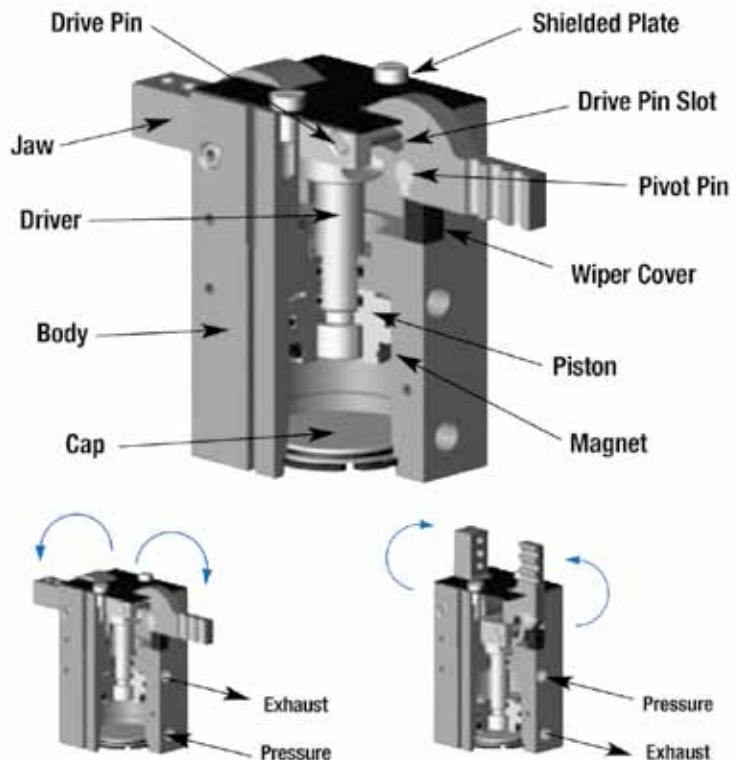

# DCT-12M DIRECTCONNECT™

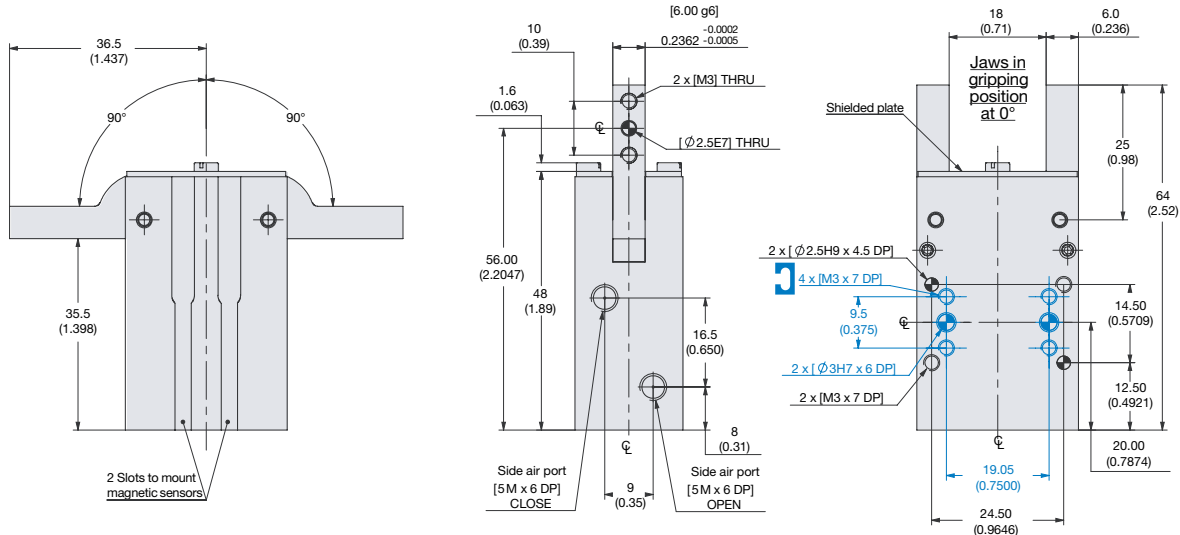

## SPECIFICATIONS DCT-12M

**Total Rated Grip Force, F @ 7 bar (100 psi)**  
**L = 25 mm (1") @ 0°: 32 N (7.2 lb)**

**Stroke: 90° of stroke for each finger**

**Weight: 0.09 Kg (0.20 lb)**

**Pressure Range: 3 to 7 bar (40 to 100 psi)**

**Cylinder Bore Ø: 12 mm (0.472")**

**Displacement: 1.92 cm<sup>3</sup> (0.117 in<sup>3</sup>)**

### TEMPERATURE RANGE

**Standard Seals: -35 to 80°C (-30 to 180°F)**

**FKM Seals: -30 to 150°C (-20 to 300°F)**

**Actuation: 0.06 sec**

**Accuracy: ±0.07 mm (±0.0028")**

**Repeatability: ±0.05 mm (±0.002")**

**Valve Required to Actuate: 4-way, 2-position**

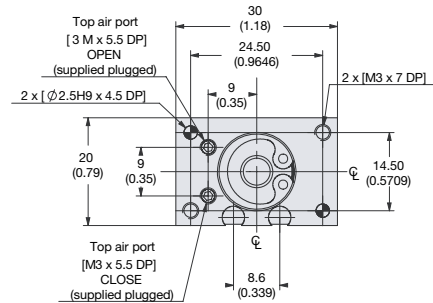
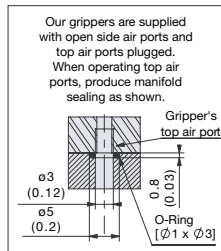

Our grippers are supplied with open side air ports and top air ports plugged. When operating top air ports, produce manifold sealing as shown.

### Dimensions: mm (inch)

**Notes:** Directconnect™ dimensions are shown in blue. Jaws have to be designed for a 0° gripping position (parallel jaws).

Jaws will close 1.5° past parallel. To limit shocks at the end of an opening or closing stroke, it is highly recommended to design jaws with minimal inertia (as light and short as possible).

Flow Controls make it possible to reduce the rotation speed and are highly recommended.

### UNLESS OTHERWISE NOTED ALL TOLERANCES ARE AS SHOWN BELOW

⊘  
Dimensions are symmetrical about centerline

⊘  
Third Angle Projection

⊘  
Metric Threads  
Course Pitch

Imperial inch  
0.00 = ±0.0  
0.000 = ±0.005  
0.0000 = ±0.0005

Metric mm  
0.0 = ±0.25  
0.0 = ±0.13  
0.00 = ±0.013

## LOADING INFORMATION

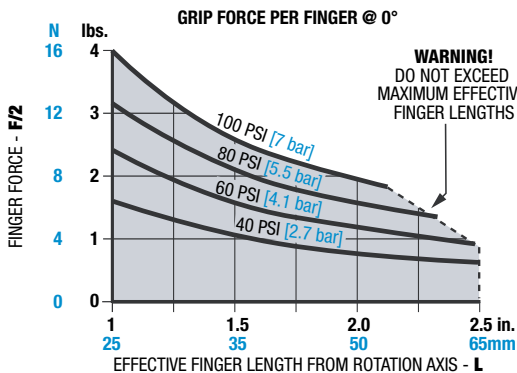

| LOADING CAPACITY†            | LOADING CAPACITY† |                  |
|------------------------------|-------------------|------------------|
|                              | STATIC            | DYNAMIC          |
| <b>DCT-12M</b>               |                   |                  |
| Maximum Tensile <b>T</b>     | 47 N (11 lb)      | 9.4 N (2 lb)     |
| Maximum Compressive <b>C</b> | 47 N (11 lb)      | 9.4 N (2 lb)     |
| Maximum Moment <b>Mx</b>     | 1.1 Nm (10 in-lb) | 0.3 Nm (3 in-lb) |
| Maximum Moment <b>My</b>     | 1.1 Nm (10 in-lb) | 0.3 Nm (3 in-lb) |
| Maximum Moment <b>Mz</b>     | 1.1 Nm (10 in-lb) | 0.3 Nm (3 in-lb) |

† Capacities are per set of jaws and are not simultaneous.



# DCT-20M DIRECTCONNECT™

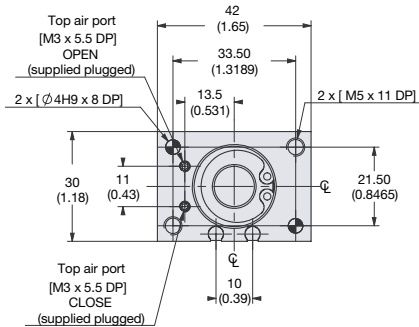
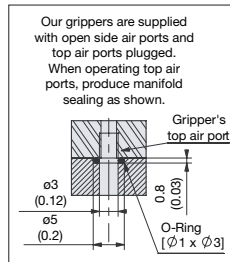
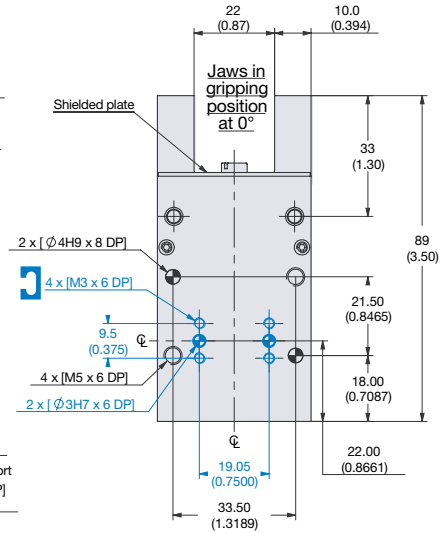
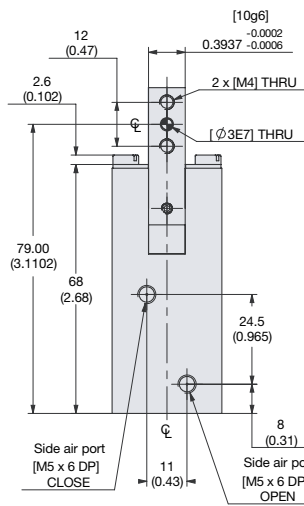
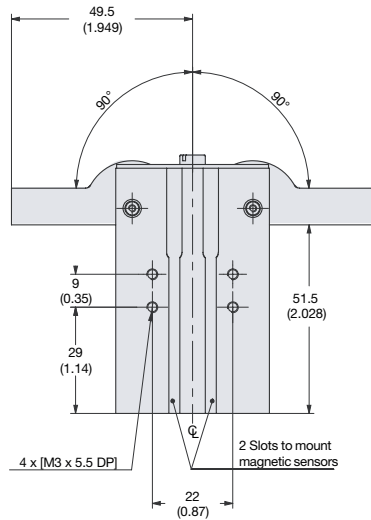

## SPECIFICATIONS DCT-20M

**TOTAL RATED GRIP FORCE, F @ 7 bar (100 psi)**

**L = 25 mm (1") @ 0°: 112 N (25 lb)**

**Stroke: 90° of stroke for each finger**

**Weight: 0.28 Kg (0.62 lb)**

**Pressure Range: 3 to 7 bar (40 to 100 psi)**

**Cylinder Bore Ø: 20 mm (0.787")**

**Displacement: 7.92 cm<sup>3</sup> (0.483 in<sup>3</sup>)**

### TEMPERATURE RANGE

**Standard Seals: -35 to 80°C (-30 to 180°F)**

**FKM Seals: -30 to 150°C (-20 to 300°F)**

**Actuation: 0.16 sec**

**Accuracy: ±0.08 mm (±0.003")**

**Repeatability: ±0.05 mm (±0.002")**

**Valve Required to Actuate: 4-way, 2-position**

### UNLESS OTHERWISE NOTED ALL TOLERANCES ARE AS SHOWN BELOW

☺  
Dimensions are symmetrical about centerline

☺  
Third Angle Projection

☺  
Metric Threads Course Pitch

**Imperial inch**  
0.00 = ±0.0  
0.000 = ±0.005  
0.0000 = ±0.0005

**Metric mm**  
0.0 = ±0.25  
0.0 = ±0.13  
0.00 = ±0.013

### Dimensions: mm (inch)

**Notes:** Directconnect™ dimensions are shown in blue. Jaws have to be designed for a 0° gripping position (parallel jaws).

Jaws will close 1.5° past parallel. To limit shocks at the end of an opening or closing stroke, it is highly recommended to design jaws with minimal inertia (as light and short as possible).

Flow Controls make it possible to reduce the rotation speed and are highly recommended.

## LOADING INFORMATION

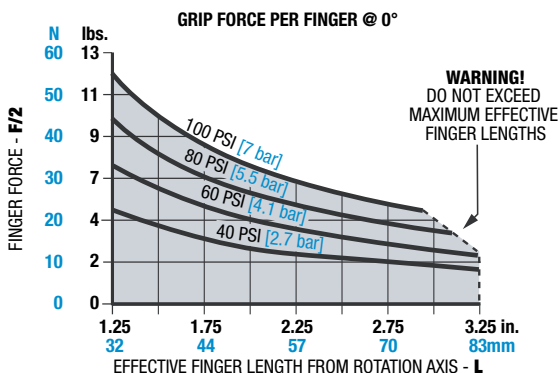

| LOADING CAPACITY†            | DCT-20M         |                   |
|------------------------------|-----------------|-------------------|
|                              | STATIC          | DYNAMIC           |
| Maximum Tensile <b>T</b>     | 150 N (34 lb)   | 30 N (7 lb)       |
| Maximum Compressive <b>C</b> | 150 N (34 lb)   | 30 N (7 lb)       |
| Maximum Moment <b>Mx</b>     | 6 Nm (53 in-lb) | 1.5 Nm (13 in-lb) |
| Maximum Moment <b>My</b>     | 6 Nm (53 in-lb) | 1.5 Nm (13 in-lb) |
| Maximum Moment <b>Mz</b>     | 6 Nm (53 in-lb) | 1.5 Nm (13 in-lb) |

† Capacities are per set of jaws and are not simultaneous.

# ACCESSORIES DIAGRAM

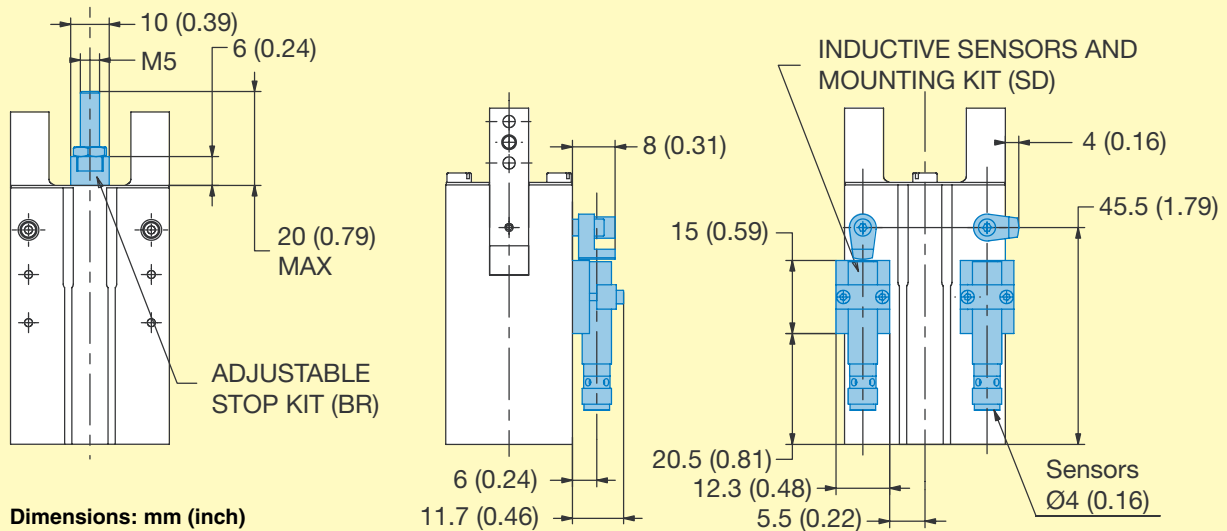

## To Order

| MODEL NO.      | DESCRIPTION  | FORCE N (lb) |
|----------------|--|--------------|
| <b>DCT-12M</b> | 180° Series angular gripper with 18 mm (0.71") jaw opening | 32 (7.2)     |
| <b>DCT-16M</b> | 180° Series angular gripper with 20 mm (0.79") jaw opening | 70 (16)      |
| <b>DCT-20M</b> | 180° Series angular gripper with 22 mm (0.87") jaw opening | 112 (25)     |

**Note:** Sensor and cable sold separately. Inductive sensor not available on DCT-12M.

**Ordering Example:** **DCT-12M**, 180° Series pneumatic angular gripper with 18 mm (0.71") jaw opening and gripper force of 32 N (7.2 lb). See air fittings for M5 threaded flow control valve, highly recommended due to jaw closing 1.5° past parallel. Suggested accessories include two PNP magneto resistive sensors with short 90° barrel **OHSP-011**, and **BR-CT-16**, adjustable stop kit.

Quick disconnect sensors will require cable, **CABL-013**, with 5 m (16') length. See accessory table below. **DCT-16M**, 180° Series pneumatic angular gripper with 20 mm (0.79") jaw opening and gripper force of 70 N (16 lb). See air fittings for M5 threaded flow control valve, highly recommended due to jaw closing 1.5° past parallel. Suggested accessories include two PNP inductive quick disconnect sensors, **OISP-014**, with two mounting kits, **SD-CT-16** and **BR-CT-16**, adjustable stop kit. Quick disconnect sensors will require cable, **CABL-013**, with 5 m (16') length. See accessory table below. CAD file available online.

## ACCESSORIES

| MODEL NO.       | QUANTITY | DESCRIPTION   |
|-----------------|----------|---|
| <b>OISP-014</b> | 1 or 2   | 4 mm PNP inductive sensor with quick disconnect                     |
| <b>OISN-014</b> | 1 or 2   | 4 mm NPN inductive sensor with quick disconnect                     |
| <b>OHSP-017</b> | 1 or 2   | PNP magneto resistive sensor long barrel with quick disconnect      |
| <b>OHSN-017</b> | 1 or 2   | NPN magneto resistive sensor long barrel with quick disconnect      |
| <b>OHSP-011</b> | 1 or 2   | PNP magneto resistive sensor short 90° barrel with quick disconnect |
| <b>OHSN-011</b> | 1 or 2   | NPN magneto resistive sensor short 90° barrel with quick disconnect |
| <b>CABL-010</b> | 1 or 2   | Quick disconnect cable 2 m (6') in length                           |
| <b>CABL-013</b> | 1 or 2   | Quick disconnect cable 5 m (16') in length                          |
| <b>BR-CT-12</b> | 1        | Adjustment stop kit (1 stop and 1 shielded plate) for DCT-12M       |
| <b>BR-CT-16</b> | 1        | Adjustment stop kit (1 stop and 1 shielded plate) for DCT-16M       |
| <b>BR-CT-20</b> | 1        | Adjustment stop kit (1 stop and 1 shielded plate) for DCT-20M       |
| <b>SD-CT-16</b> | 1 or 2   | Inductive sensor mounting kit for DCT-16M                           |
| <b>SD-CT-20</b> | 1 or 2   | Inductive sensor mounting kit for DCT-20M                           |