

User's Guide



Shop online at

omega.com[®]

ΩOMEGA

omega.com

e-mail: info@omega.com

For latest product manuals:

omegamanual.info

ISO 9001
CERTIFIED
CORPORATE QUALITY

STAMFORD, CT

ISO 9002
CERTIFIED
CORPORATE QUALITY

MANCHESTER, UK

BV80 Series
Premium Quality Maintenance Free Bar
Stock Ball Valves



OMEGAnet® Online Service omega.com	Internet e-mail info@omega.com
---------------------------------------	-----------------------------------

Servicing North America:

U.S.A.: One Omega Drive, P.O. Box 4047
ISO 9001 Certified Stamford, CT 06907-0047
 TEL: (203) 359-1660 FAX: (203) 359-7700
 e-mail: info@omega.com

Canada: 976 Bergar
 Laval (Quebec) H7L 5A1, Canada
 TEL: (514) 856-6928 FAX: (514) 856-6886
 e-mail: info@omega.ca

For immediate technical or application assistance:

U.S.A. and Canada: Sales Service: 1-800-826-6342 / 1-800-TC-OMEGA®
 Customer Service: 1-800-622-2378 / 1-800-622-BEST®
 Engineering Service: 1-800-872-9436 / 1-800-USA-WHEN®
 TELEX: 996404 EASYLINK: 62968934 CABLE: OMEGA

Mexico: En Español: (001) 203-359-7803 e-mail: espanol@omega.com
 FAX: (001) 203-359-7807 info@omega.com.mx

Servicing Europe:

Benelux: Postbus 8034, 1180 LA Amstelveen, The Netherlands
 TEL: +31 (0)20 3472121 FAX: +31 (0)20 6434643
 Toll Free in Benelux: 0800 0993344
 e-mail: sales@omegaeng.nl

Czech Republic: Frystatska 184, 733 01 Karviná, Czech Republic
 TEL: +420 (0)59 6311899 FAX: +420 (0)59 6311114
 Toll Free: 0800-1-66342 e-mail: info@omegashop.cz

France: 11, rue Jacques Cartier, 78280 Guyancourt, France
 TEL: +33 (0)1 61 37 2900 FAX: +33 (0)1 30 57 5427
 Toll Free in France: 0800 466 342
 e-mail: sales@omega.fr

Germany/Austria: Daimlerstrasse 26, D-75392 Deckenpfronn, Germany
 TEL: +49 (0)7056 9398-0 FAX: +49 (0)7056 9398-29
 Toll Free in Germany: 0800 639 7678
 e-mail: info@omega.de

United Kingdom: One Omega Drive, River Bend Technology Centre
ISO 9002 Certified Northbank, Irlam, Manchester
 M44 5BD United Kingdom
 TEL: +44 (0)161 777 6611 FAX: +44 (0)161 777 6622
 Toll Free in United Kingdom: 0800-488-488
 e-mail: sales@omega.co.uk

It is the policy of OMEGA Engineering, Inc. to comply with all worldwide safety and EMC/EMI regulations that apply. OMEGA is constantly pursuing certification of its products to the European New Approach Directives. OMEGA will add the CE mark to every appropriate device upon certification.

The information contained in this document is believed to be correct, but OMEGA accepts no liability for any errors it contains, and reserves the right to alter specifications without notice.

WARNING: These products are not designed for use in, and should not be used for, human applications.

MATERIALS OF CONSTRUCTION

BODY: Brass - ASTM B-16, or 316 Stainless Steel - ASTM A276

BALL AND STEM: 316 Stainless Steel

SEATS AND STEM SEAL: Glass Reinforced P.T.F.E. (Teflon®)

CONNECTION / STYLE SIZES

Pipe / N.P.T.F. 1/4" - 2"
(Dryseal National Pipe Taper)

RATINGS

TEMPERATURE: -50 F to 450 F
(also see Pressure Temperature Chart)

PRESSURE: 720 p.s.i. C.W.P. (Cold Working Pressure to 150 F)
(also see Pressure Temperature Chart)

VACUUM: 20 Micron

SATURATED STEAM: 150 p.s.i.

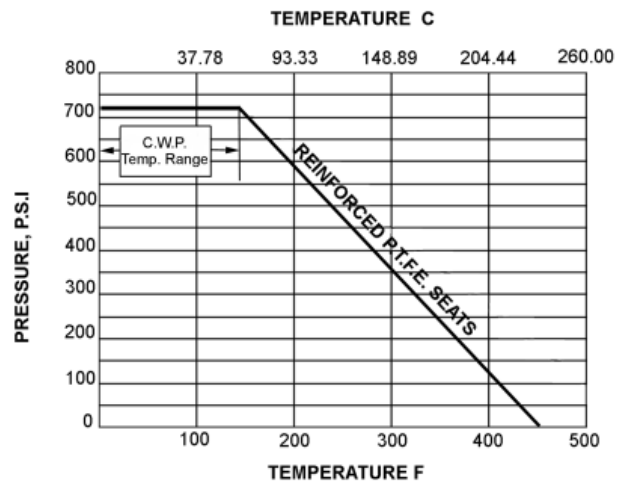

FLOW CHARACTERISTICS

The approximate flow rate through a valve can be calculated as follows:

$$Q = C_v \sqrt{\frac{\Delta P}{G}}$$

where; Q = flow rate in gallons (U.S. Std.) per minute
Cv = valve constant
P = pressure drop across the valve in pounds per square inch
G = specific gravity of the media of relative to water

Note: The values derived from the flow equation are for estimating purposes only. Product variances or systemic factors may alter actual performance.

Size	1/4	3/8	1/2	3/4	1	1-1/4	1-1/2	2
Cv	5.5	5.5	8	12	32	46	82	120

INSTALLATION INSTRUCTIONS

The following serves as a guideline for those experienced in pipe joint makeup. Otherwise, services of a certified pipe fitter should be utilized for installation.

1. Ensure that both the male pipe and female valve threads are free from dirt, debris and corrosion. Wire brushing of the male pipe threads is recommended to ensure a good metal-to-metal joint.
2. Apply a good quality thread lubricant (pipe dope) on the male threads. Lubricant reduces friction when pulling up the pipe joint. Note, thread lubricant is not intended to seal the joint and will not compensate for poor quality male pipe or fitting threads.
3. Turn the female valve threads onto the male pipe threads by hand. Upon free engagement of the threads, continue to turn the valve as far up as it will go (by hand). With the use of a wrench continue to tighten the valve onto the pipe. The pipe joint seal should occur within 1 to 3 turns after wrenching begins. Care should be taken not to exceed 3 turns in which damage to the threads can occur.
4. The pipe joint should be tested for leakage to ensure the pipe joint has been achieved.

MAINTENANCE

The BV80 Series utilizes our self compensating stem seal design. This design automatically compensates for wear as well as thermal expansion and contraction resulting in a leak tight, maintenance free, service life.

Once the stem seal has worn beyond the compensation afforded by the Belleville springs adjustment of the stem nut may enable valve to be returned to service. Holding the 'flats' of the stem, tighten the stem nut until Belleville springs become fully compressed (flattened); the torque required to tighten the nut further increases sharply when this point is reached. Do not tighten the stem nut beyond this point to avoid damage of the stem seal.

DIMENSIONS

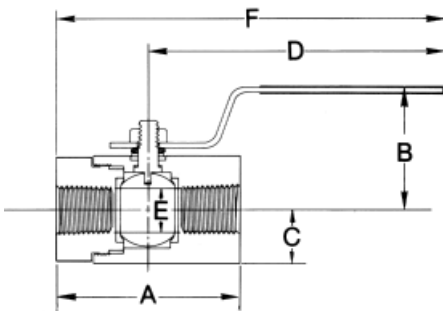

Size	Dimensions - Inches						Dimensions - Millimeters					
	A	B	C	D	E	F	A	B	C	D	E	F
1/4 & 3/8	2.22	1.75	0.50	4.00	0.36	5.09	56.4	44.4	12.7	101.6	9.1	129.3
1/2	2.61	1.84	0.59	4.00	0.49	5.30	66.3	46.7	15.0	101.6	12.4	134.6
3/4	2.94	2.00	0.75	5.38	0.62	6.85	74.7	50.8	19.0	136.7	15.8	174.0
1	3.32	2.28	1.00	5.38	0.80	7.04	84.3	58.0	25.4	136.7	20.3	179.0
1-1/4	3.70	2.93	1.06	6.75	0.97	8.60	94.0	74.4	26.9	171.4	24.6	218.4
1-1/2	4.25	3.19	1.31	6.75	1.25	8.87	108.0	81.0	33.3	171.4	31.8	225.3
2	4.57	3.37	1.50	6.75	1.50	9.41	116.1	85.6	38.1	171.4	38.1	239.0



WARRANTY/DISCLAIMER

OMEGA ENGINEERING, INC. warrants this unit to be free of defects in materials and workmanship for a period of **13 months** from date of purchase. OMEGA's WARRANTY adds an additional one (1) month grace period to the normal **one (1) year product warranty** to cover handling and shipping time. This ensures that OMEGA's customers receive maximum coverage on each product.

If the unit malfunctions, it must be returned to the factory for evaluation. OMEGA's Customer Service Department will issue an Authorized Return (AR) number immediately upon phone or written request. Upon examination by OMEGA, if the unit is found to be defective, it will be repaired or replaced at no charge. OMEGA's WARRANTY does not apply to defects resulting from any action of the purchaser, including but not limited to mishandling, improper interfacing, operation outside of design limits, improper repair, or unauthorized modification. This WARRANTY is VOID if the unit shows evidence of having been tampered with or shows evidence of having been damaged as a result of excessive corrosion; or current, heat, moisture or vibration; improper specification; misapplication; misuse or other operating conditions outside of OMEGA's control. Components in which wear is not warranted, include but are not limited to contact points, fuses, and triacs.

OMEGA is pleased to offer suggestions on the use of its various products. However, OMEGA neither assumes responsibility for any omissions or errors nor assumes liability for any damages that result from the use of its products in accordance with information provided by OMEGA, either verbal or written. OMEGA warrants only that the parts manufactured by the company will be as specified and free of defects. OMEGA MAKES NO OTHER WARRANTIES OR REPRESENTATIONS OF ANY KIND WHATSOEVER, EXPRESSED OR IMPLIED, EXCEPT THAT OF TITLE, AND ALL IMPLIED WARRANTIES INCLUDING ANY WARRANTY OF MERCHANTABILITY AND FITNESS FOR A PARTICULAR PURPOSE ARE HEREBY DISCLAIMED. LIMITATION OF LIABILITY: The remedies of purchaser set forth herein are exclusive, and the total liability of OMEGA with respect to this order, whether based on contract, warranty, negligence, indemnification, strict liability or otherwise, shall not exceed the purchase price of the component upon which liability is based. In no event shall OMEGA be liable for consequential, incidental or special damages.

CONDITIONS: Equipment sold by OMEGA is not intended to be used, nor shall it be used: (1) as a "Basic Component" under 10 CFR 21 (NRC), used in or with any nuclear installation or activity; or (2) in medical applications or used on humans. Should any Product(s) be used in or with any nuclear installation or activity, medical application, used on humans, or misused in any way, OMEGA assumes no responsibility as set forth in our basic WARRANTY/DISCLAIMER language, and, additionally, purchaser will indemnify OMEGA and hold OMEGA harmless from any liability or damage whatsoever arising out of the use of the Product(s) in such a manner.

RETURN REQUESTS/INQUIRIES

Direct all warranty and repair requests/inquiries to the OMEGA Customer Service Department. BEFORE RETURNING ANY PRODUCT(S) TO OMEGA, PURCHASER MUST OBTAIN AN AUTHORIZED RETURN (AR) NUMBER FROM OMEGA'S CUSTOMER SERVICE DEPARTMENT (IN ORDER TO AVOID PROCESSING DELAYS). The assigned AR number should then be marked on the outside of the return package and on any correspondence.

The purchaser is responsible for shipping charges, freight, insurance and proper packaging to prevent breakage in transit.

FOR **WARRANTY** RETURNS, please have the following information available BEFORE contacting OMEGA:

1. Purchase Order number under which the product was PURCHASED,
2. Model and serial number of the product under warranty, and
3. Repair instructions and/or specific problems relative to the product.

FOR **NON-WARRANTY** REPAIRS, consult OMEGA for current repair charges. Have the following information available BEFORE contacting OMEGA:

1. Purchase Order number to cover the COST of the repair,
2. Model and serial number of the product, and
3. Repair instructions and/or specific problems relative to the product.

OMEGA's policy is to make running changes, not model changes, whenever an improvement is possible. This affords our customers the latest in technology and engineering.

OMEGA is a registered trademark of OMEGA ENGINEERING, INC.

© Copyright 2005 OMEGA ENGINEERING, INC. All rights reserved. This document may not be copied, photocopied, reproduced, translated, or reduced to any electronic medium or machine-readable form, in whole or in part, without the prior written consent of OMEGA ENGINEERING, INC.

Where Do I Find Everything I Need for Process Measurement and Control? **OMEGA...Of Course!** *Shop online at omega.com*

TEMPERATURE

- ☑ Thermocouple, RTD & Thermistor Probes, Connectors, Panels & Assemblies
- ☑ Wire: Thermocouple, RTD & Thermistor
- ☑ Calibrators & Ice Point References
- ☑ Recorders, Controllers & Process Monitors
- ☑ Infrared Pyrometers

PRESSURE, STRAIN AND FORCE

- ☑ Transducers & Strain Gages
- ☑ Load Cells & Pressure Gages
- ☑ Displacement Transducers
- ☑ Instrumentation & Accessories

FLOW/LEVEL

- ☑ Rotameters, Gas Mass Flowmeters & Flow Computers
- ☑ Air Velocity Indicators
- ☑ Turbine/Paddlewheel Systems
- ☑ Totalizers & Batch Controllers

pH/CONDUCTIVITY

- ☑ pH Electrodes, Testers & Accessories
- ☑ Benchtop/Laboratory Meters
- ☑ Controllers, Calibrators, Simulators & Pumps
- ☑ Industrial pH & Conductivity Equipment

DATA ACQUISITION

- ☑ Data Acquisition & Engineering Software
- ☑ Communications-Based Acquisition Systems
- ☑ Plug-in Cards for Apple, IBM & Compatibles
- ☑ Datalogging Systems
- ☑ Recorders, Printers & Plotters

HEATERS

- ☑ Heating Cable
- ☑ Cartridge & Strip Heaters
- ☑ Immersion & Band Heaters
- ☑ Flexible Heaters
- ☑ Laboratory Heaters

ENVIRONMENTAL MONITORING AND CONTROL

- ☑ Metering & Control Instrumentation
- ☑ Refractometers
- ☑ Pumps & Tubing
- ☑ Air, Soil & Water Monitors
- ☑ Industrial Water & Wastewater Treatment
- ☑ pH, Conductivity & Dissolved Oxygen Instruments