

**1 YEAR**  
WARRANTY

# **Ω OMEGA®** **User's Guide**



***Shop online at  
omega.com<sup>SM</sup>***

***e-mail: info@omega.com  
For latest product manuals:  
omegamanual.info***

## **PX5200** **Differential Pressure Transmitter**

**M5109/0817**



omega.com info@omega.com

## **Servicing North America:**

**U.S.A.  
Headquarters:**

Omega Engineering, Inc.

Toll-Free: 1-800-826-6342 (USA & Canada only)

Customer Service: 1-800-622-2378 (USA & Canada only)

Engineering Service: 1-800-872-9436 (USA & Canada only)

Tel: (203) 359-1660

Fax: (203) 359-7700

e-mail: info@omega.com

**For Other Locations Visit [omega.com/worldwide](http://omega.com/worldwide)**

---

## CONTENTS

<b>CAUTION</b> .....	4-5
<b>1. PREFACE</b> .....	5
<b>2. OVERVIEW</b> .....	5
<b>3. FEATURES</b> .....	5
<b>4. SPECIFICATIONS</b> .....	6
<b>5. MOUNTING</b> .....	8
5.1 Mounting Location .....	8
5.2 Mounting Options .....	8
5.3 Pressure Connection .....	8
<b>6. PIPING</b> .....	9
<b>7. WIRING</b> .....	10
7.1 Cable / Wiring Specifications .....	10
7.2 Wiring Instructions .....	10
<b>8. DISPLAY FUNCTIONS</b> .....	13
<b>9. MODE CHANGES</b> .....	14
<b>10. POWER-ON MESSAGE</b> .....	14
<b>11. MEASUREMENT MODE</b> .....	15
11.1 Filter (Damping) .....	15
11.2 Pressure Display Mode (Re-scaling in "inH <sub>2</sub> O" units) .....	15
11.3 Linear Display Mode (Re-scaling in arbitrary user defined units) .....	16
11.4 Flow Measurement/Square Root Extraction Mode .....	19
11.5 Min/Max Display .....	26
<b>12. ZERO ADJUSTMENT MODE</b> .....	27
<b>13. KEY LOCK</b> .....	28
<b>14. SETTING MODE</b> .....	20
14.1 Setting Items for Pressure Display Mode (Re-scaling in "inH <sub>2</sub> O" units) .....	28
14.2 Setting Items for Linear Display Mode (Re-scaling in arbitrary user defined units) .....	29
14.3 Setting Items for Square Root Extraction (Flow Measurement) ..	31
14.4 Setting Procedure .....	32
14.5 Loop Check .....	34
<b>15. DIMENSIONAL DRAWINGS</b> .....	35
<b>16. MAINTENANCE</b> .....	36



## **WARNING! READ BEFORE INSTALLATION**



### **GENERAL:**

A failure resulting in **injury** or **damage** may be caused by excessive overpressure, excessive vibration or pressure pulsation, excessive instrument temperature, corrosion of the pressure containing parts, or other misuse.

### **OVERPRESSURE:**

Pressure spikes in excess of the rated overpressure capability of the transmitter may cause **irreversible electrical and/or mechanical damage** to the pressure measuring and containing elements.

**Fluid hammer** and surges can destroy any pressure transmitter and must always be avoided. A pressure snubber should be installed to eliminate the damaging hammer effects. Fluid hammer occurs when a liquid flow is suddenly stopped, as with quick closing solenoid valves. Surges occur when flow is suddenly begun, as when a pump is turned on at full power or a valve is quickly opened.

**Liquid surges** are particularly damaging to pressure transmitters if the pipe is originally empty. To avoid damaging surges, fluid lines should remain full (if possible), pumps should be brought up to power slowly, and valves opened slowly. To avoid damage from both fluid hammer and surges, a surge chamber should be installed.

Symptoms of fluid hammer and surge's damaging effects:

- Pressure transmitter exhibits an output at zero pressure (large zero offset).
- Pressure transmitter output remains constant regardless of pressure
- In severe cases, there will be no output.

### **FREEZING:**

Prohibit freezing of media in pressure port. Unit should be drained to prevent possible overpressure damage from frozen media.

### **STATIC ELECTRICAL CHARGES:**

Any electrical device may be susceptible to damage when exposed to static electrical charges. To avoid damage to the transmitter observe the following:

- Ground the body of the transmitter **BEFORE** making any electrical connections.
- When disconnecting, remove the ground **LAST!**

---

Note: The shield and drain wire in the cable (if supplied) is not connected to the transmitter body, and is not a suitable ground.

## 1. PREFACE

Thank you for purchasing the PX5200 Rangeable Differential Pressure Transmitter. Refer to the Omega PX5200 Data Sheet for product specifications and applicable operating conditions.

## 2. OVERVIEW

The PX5200 is a 4-20mA loop powered (two-wire) differential pressure transmitter with integral display incorporating Ashcroft's proven SiGlas silicon based variable capacitance sensor with stainless steel media isolation diaphragms and silicone pressure transmission fluid. The device was designed to offer the user small size and user adjustable ranging for applications such as tank level measurements and gas / liquid flow measurements.

## 3. FEATURES

- (1) **Media Compatibility:** Wetted materials consist of 316 stainless steel, alumina ceramic and viton to handle a wide range of media with the ability to offer ranges as low as 4" W.C. F.S. (URL).
- (2) **Linear Scaling Function:** The linear (scaling) function allows the user to adjust zero and span values providing a corresponding 4-20mA output signal.
- (3) **Flow Measurement/Square Root Extraction Function:** Momentary flow rate and integrated volume can be displayed and analog signal can be output.
- (4) **Digital Filter Function:** User adjustable damping of the output signal by means of internally calculated moving average to provide a stable output signal in applications where the user wants to reduce the pulsating of the display and / or output signal.
- (5) **LED Back Light:** To supplement the LCD display when conditions require (dark area, night etc.).
- (6) **Loop Check Function:** Allows the user to output an analog signal corresponding to differential pressure without applying pressure, simplifying system maintenance and troubleshooting.

- (7) **Zero and Span Adjustment:** The adjustment of the Zero (4mA) and Span (20mA) reading via internal push buttons.
- (8) **Key Lock Function:** Prevents inadvertent overwriting of setting values. Can not be reset by restoring power when activated.
- (9) **IP65 / NEMA 4X Environmental Rating:** Enclosure environmental rating suitable for indoor and outdoor installation, depending upon operating temperature range.\*
- \*Display not to be mounted in direct sunlight.

#### 4. SPECIFICATIONS

ITEM	DESCRIPTION
<b>1. Media/Wetted Parts</b>	Gas or liquid compatible with 316SS, viton and alumina ceramic (isolation fluid is silicone oil). Media temperature range: -10 to +70°C
<b>2. Overpressure (Proof)</b>	Static (Line) Pressure: 300psi all ranges Single Side (Differential) Limits: • Pressure Ranges <8°W.C., ±4°W.C.; 30psid • Pressure Ranges >20°W.C., ±8°W.C.; 100psid
<b>3. Supply Voltage</b>	12-32Vdc
<b>4. Output</b>	4-20mAdc (two wires, Output range: 3.2 to 20.8mAdc) Response Time: 100ms (with "0" filter setting) Resolution: 0.1%F.S., Load resistance: 500 max.
<b>5. Accuracy</b>	±0.5% F.S. (URL) at 73°F (23°C); includes the effects of non-linearity, hysteresis and non-repeatability)
<b>6. Display Accuracy</b>	±0.50% F.S. (URL) + 1 digit at 23°C

<b>7. Rangeability / Adjustment</b>	Zero: -10 to +110% FS Span: -10 to + 110% FS
<b>8. Display</b>	Character height: 10mm, with LCD display with LED backlight Pressure / linear display: (4) LCD digits max. Display update: 500 ms
<b>9. Units</b>	Pressure Units: inH <sub>2</sub> O (2), (1) arbitrary
<b>10. Setting Adjustments</b>	Internal key switches (Mode, ⏪, ⏩) Scaling function: Linear output, linear and momentary flow rate display/output. Filter function: User adjustable output damping select from 0, 2, 4, 8 and 16 (None, 2, 4, 8, and 16 (s)). Loop check function: User adjustable output for loop/system check and troubleshooting, 4-20mA.
<b>11. Enclosure</b>	Material: Aluminum die cast Environmental Rating: IP65 / NEMA 4X
<b>12. Pressure Connection</b>	¼ NPT female pressure ports w/equalizing valve
<b>13. Electrical Termination</b>	Cable Gland (Optional): Cable diameter 0.35 to 0.47" (9-12mm) ½ NPT Female Conduit Adapter (Optional) Terminal Block: 14-22 AWG (stranded or solid wire)
<b>14. Memory Protection</b>	Permanently stored by EEPROM (nonvolatile memory)
<b>15. EMC Directive</b>	
<b>16. Operating Temperature</b>	-10 to 60°C (14 to 140°F)
<b>17. Storage Temperature</b>	-20 to 70°C (-4 to 158°F)
<b>18. Vibration</b>	5g's, 150Hz
<b>19. Shock</b>	10g's, 16ms
<b>20. Insulation Resistance</b>	50Vdc, 100MΩ or more
<b>21. Weight</b>	Approx. 670g (1.5lbs)

---

## 5. MOUNTING

### 5.1 General

The GC52 was designed to be mounted using the bracket supplied. Pressure connections via the (2) 1/4" NPT female pressure ports. Although the display can be rotated in 90 degree increments by removing the display cover it is preferable to orientate the electrical termination downward, particularly in applications where protection from the environment is required.

### 5.2 Mounting Orientation

It is preferable to orientate the unit with the pressure ports either downward or upward. If mounting with pressure ports to the side an "orientation effect" will be seen at zero pressure as the pressure generated by the silicone oil fill will appear as a zero offset. If mounting in this manner this effect may be taken out by re-setting zero in final mounting orientation.

### 5.3 Installing Pressure Port Manifold

#### (1) Mounting 25.4mm Manifold (1/4" NPT female ports)

Manifold is secured using the (4) socket head bolts (M4x40) and appropriate allen wrench which is supplied. Check for dust and dirt on the O-ring and seal area, clean if necessary, before installing to ensure proper connection. The direction of the manifold is not important, determine best position by ability to operate the equalizing valve. The equalizing valve is used to open both ports to the line pressure at time of installation. Once installed and the system has been pressurized the valve needs to be closed to isolate the low and high pressure sides of the device.

**Tighten the equalizing valve with a torque of 0.75 ft-lbs±15%. When loosening the valve do not back off by more than three turns from the closed position.**

#### (2) Panel Mounting

Similar to (1) above except that the PX5200 is put between the manifold and the bracket and then the (4) socket head bolts (M4x40) are installed.



## Lower connection diagram

Connection: Lower side.

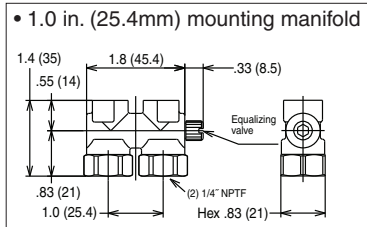

## 6. PIPING

Note: High (H) and Low (L) pressure sides of the device are marked on the yellow label affixed to the housing of the unit.

Install the high pressure side of the applied differential pressure in the pressure inlet of the high pressure side (H) and the low pressure side in the pressure inlet of the low pressure side (L).

(Refer to the outline drawing of section 14.)

After the piping is completed check for leaks.

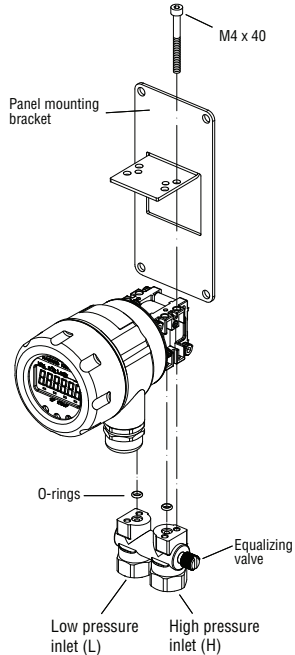

### (1) Piping of 1.0 in (25.4mm) Manifold (1/4" npt female ports)

Use caution when installing to keep metal chips and other debris from entering pressure transmitter. In addition, when sealing tape is used, do not apply to last two threads at the end of the fitting

---

**Note:**

- When transporting and / or mounting do not apply excessive shock or use device as a step.
- The piping should be of proper length so as not to apply load to the connection point on the transmitter.
- At the time of mounting or when bleeding air from the device be sure to open the equalizing valve with a flathead screwdriver so that excessive pressure (more than the allowable maximum differential pressure) is not applied to the differential pressure sensor. Maximum torque to apply to equalizer valve is 0.75 ft-lbs  $\pm$ 5%.

**7. WIRING****7.1 Cable/Wire Specifications**

Use appropriate cable described below which is suitable for power supply requirements and ground to housing.

Terminal Strip	SMKDSP1.5/2-5.08 Phoenix Contact
Cable Requirements	<ul style="list-style-type: none"><li>• Two core shielded cable</li><li>• Cable outer diameter: 0.35" to 0.47" 9-12mm (Required for correct installation with Cable Gland option)</li><li>• Wire Gauge: 14-22 AWG (multi-strand or solid)</li></ul>

**7.2. Wiring Instructions**

- To reduce potential for noise do not run pressure transmitter cable / wires alongside (same conduit as) high voltage (line power) lines. For optimum results use dedicated conduit for PX5200 cable / wires.
- If using the Cable Gland termination option must use cable within previously noted diameters to maintain environmental ratings.
- When connecting shield / drain wire, only connect one end which should be at the receiver ground.
- Wiring stripping instructions, remove cable jacket 2-3" and strip wires  $\pm$ 0.25". Shield / drain wire should not be exposed at the pressure transmitter termination.
- Remove cover and carefully remove the display to access the terminal strip, take care not to mishandle the display and associated electronics.

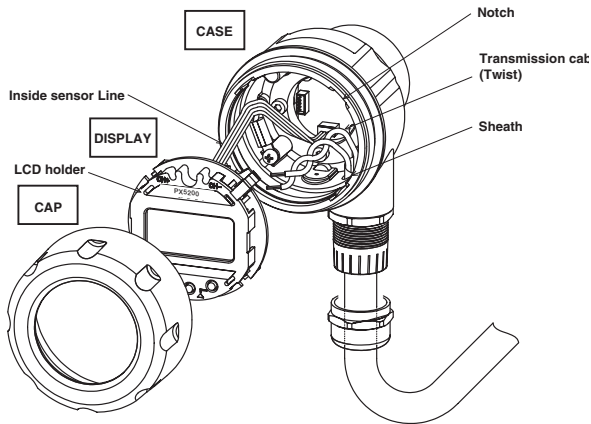
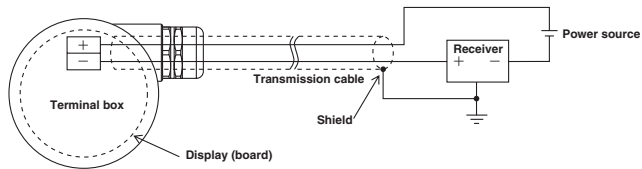

- Turn display over to expose terminal strip, make positive and negative connections, insert wire depth is equal to recommended strip length (0.25").

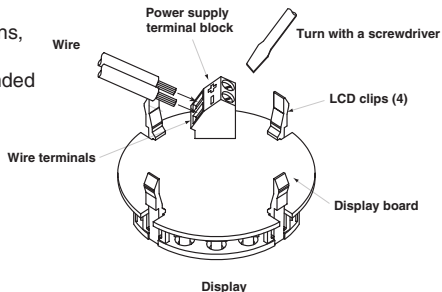

- After completing connections locate retaining clips in the appropriate notches and carefully place into the housing. Be sure that internal sensor transmission wire does not cross the power supply lines just installed.
- If using the Cable Gland be sure to properly tighten sealing grommet before applying any tension on the cable, the cable gland provides strain relief and environmental sealing.
- Tighten GC52 cover to maintain environmental rating.
- Connect to power source and receiver and power on to confirm correct wiring (see Section 10 for more detail).
- Power Supply Requirements: Although the 4-20mA signal can travel over long distances one of the most common problems is inadequate power at the pressure transmitter due to the voltage drop across the loop. Be sure to review table below to determine that 12-32V is getting to the pressure transmitter.

### Load Limitations 4-20mA Output Only

Loop Resistance ( $\Omega$ )

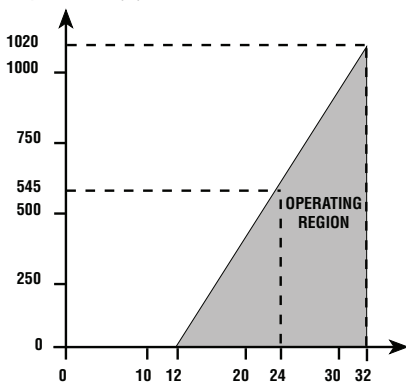

## 8. DISPLAY FUNCTIONS

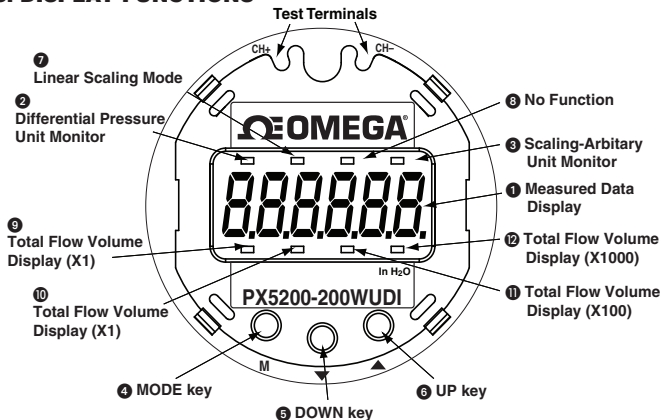

DESIGNATION	FUNCTION
① <b>Measured data display</b>	Differential pressure, linear scaling value are displayed.
② <b>Differential pressure unit monitor</b>	When this unit monitor is ON, the differential pressure (in H <sub>2</sub> O) is indicated on the measured data display.
③ <b>Scaling; arbitrary unit monitor</b>	When this unit monitor is ON, the scaling value of an arbitrary unit (linear scaling), is indicated on the measured data display.
④ <b>MODE key (M)</b>	This key is used to switch the setting mode and the measurement mode and to change the setting item.
⑤ <b>DOWN key</b> ▼	This key is used to change (decrease) and select the set value .
⑥ <b>UP key</b> ▲	This key is used to change (increase) and to shift from the measurement mode to the zero adjustment mode.

DESIGNATION	FUNCTION
⑦ <b>Linear scaling mode</b>	Used to adjust zero/ span values to 4-20mA output signal.
⑧ <b>No function</b>	None
⑨ to ⑫ <b>Total flow volume display</b>	

## 9. MODE CHANGES

- Measurement Mode (Section 11 for further detail) will be entered upon power-on. Setting Mode (Section 14 for further detail) is entered by pressing and holding the MODE button for more than 3 seconds. If there is no button operation for 10 minutes in the setting mode, it will shift back to the Measurement Mode automatically.
- To go from the Measurement Mode to the Zero Adjustment Mode (Section 12 for further detail) press and hold the UP ▲ button for more than 3 seconds.

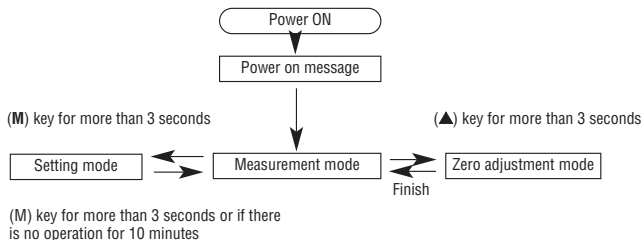

## 10. POWER-ON MESSAGE

After the power is turned on, the power-on message is displayed for 6 seconds as shown below and then the display is shifted to the measurement mode (section 11). In addition, the analog output during power-on message is at the zero point (4mA).

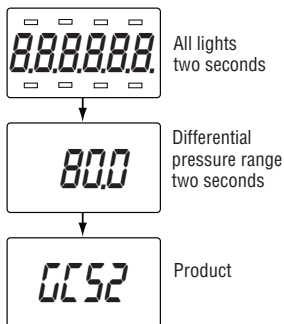

---

## 11. MEASUREMENT MODE

The measurement mode includes differential pressure display mode, and linear (scaling) display mode. For the setting items ① to ⑳, please refer to the Setting Mode (section14).

### 11.1 Filter

Set the filter before setting pressure display mode or linear (scaling) display mode.

The filter is based on the moving average of the pressure data to decrease display “bounce” and to smooth the analog output due to system pressure fluctuations at the user’s discretion.

Five selections: (0, 2, 4, 8, and 16 seconds).

If “0” is selected the filter is not applied.

See Section 14.4 for full menu.

Filter Setting	⇒ item ①
----------------	----------

### 11.2 Differential Pressure Display Mode (Re-scaling in “inH<sub>2</sub>O” units)

This mode is used for display and analog output of the actual differential pressure.

#### (1) Analog output

The analog output can be adjusted as follows; the zero point (4mA) and the span point (20mA) can each be adjusted from -10 to 110%F.S. (URL)\*.

#### (2) Pressure display

The **pressure display** has a display span between the zero point and the span point as determined by the adjustment of zero and span (see previous paragraph) and can display the range of -5 to 105%F.S.(URL). In addition, the decimal point position of the pressure display is fixed for each pressure range.

**Pressure Unit:** in.H<sub>2</sub>O

See Section 14.4 for full menu.

Output zero point and span point setting	⇒ Setting item ③, ④
--	---------------------

\*This means that although the zero point is typically set at 0%F.S. (in the case of bi-directional ranges 0%Span) and the span point is set as 100%F.S., the zero point can be adjusted to the point where zero (4mA) is 110%F.S. and the span point (20mA) can be adjusted to -10%F.S thus reversing the output. In addition, through this adjustment zero and span can be adjusted accordingly for elevated tank levels.

### Setting example 1 : Differential pressure display mode

The setting to use the differential pressure range 0 to 20in.H<sub>2</sub>O ("W.C.") and to display the zero point and span point of the analog output as -2 in.H<sub>2</sub>O and 18 in.H<sub>2</sub>O respectively is as follows:

In the example the filter (moving average time) is set at 2 seconds, the differential pressure display and the analog output are based on the moving average equivalent to the differential pressure data per 100ms for the past 2 seconds (20 times).

Select the filter of "2 seconds"	⇒ Setting item ①
Select the "Differential pressure display mode"	⇒ Setting item ②
Set output zero point as "-10.0%F.S."	⇒ Setting item ③
Set output span point as "90.0%F.S."	⇒ Setting item ④

#### ■ Display and analog output

Ex. Differential pressure of 8 inH<sub>2</sub>O

- Differential pressure display: 8.00(H<sub>2</sub>O)
- Analog output: 12(mA) in.H<sub>2</sub>O



	Differential Pressure Display (inH <sub>2</sub> O)	Analog Output (mA)
Output span point	18.00 ⇒ 20	12
	∫	∫
	8.00 ⇒ 12	
Output zero points	-2.00 ⇒ 4	

### 11.3 Linear Display Mode (Re-scaling in arbitrary user defined units)

This mode is used for display / analog output of the scaling value where the differential pressure is linearly converted to an arbitrary physical quantity.

#### (1) Linear display

By setting the OFFSET to the minimum differential pressure P<sub>1</sub> and the FULL SCALE to the maximum differential pressure P<sub>2</sub>, the linear display indicates the value on the line between the two points (the maximum display span). The actual linear display span depends on the setting of the zero point and span point of the analog output as shown in (2) of the next page. It can display the range of -5 to 105%F.S. of the linear display span.



- The setting range for the **minimum differential pressure  $P_1$**  and the **maximum differential pressure  $P_2$**  is 0 to 100%F.S. of the differential pressure range, and the maximum differential pressure  $P_2$  is set from the value which is more than 25%F.S. of the differential pressure range above the minimum differential pressure  $P_1$ .
- The setting range for the **OFFSET** and **FULL SCALE** values is -1999 to 1999, and the decimal point can be set arbitrarily. At this time, the arbitrary unit monitor turns on

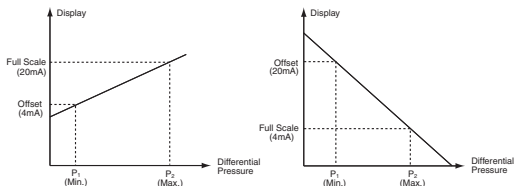

See Section 14.4 for full menu.

Min. differential pressure $P_1$ and max. differential pressure $P_2$ setting	⇒ Setting item ⑥, ⑦
OFFSET & FULL SCALE setting	⇒ Setting item ⑧, ⑨, ⑩

## (2) Analog output

The zero point (4mA) and span point (20mA) of analog output can be set in the range of -10 to 110%F.S. of the maximum display span (between OFFSET and FULL SCALE). The span between the zero point and the span point in this analog output is the linear display span.

Analog output zero point and span point setting	Setting item ⑪, ⑫
--	-------------------

As shown in the previous diagram, usually, the OFFSET is set as Output zero point (4mA) and the FULL SCALE is set as Output span point (20mA), but the OFFSET can be reversed to Output span point (20mA) and the FULL SCALE can be reversed to Output zero point (4mA).

### ■ Setting example 2 : Linear display mode

A level gauge using a differential pressure range of 0 to 200 in.H<sub>2</sub>O, the linear display setting to display the OFFSET for minimum 20 in.H<sub>2</sub>O as 0.0, the FULL SCALE for maximum differential pressure 120 in.H<sub>2</sub>O as 50.0, the unit as arbitrary unit (m), the zero point (4mA) analog output as 0.0, and the span point (20mA) as 50.0 is as follows:

See Section 14.4 for full menu.

For display mode, select "Linear display mode"	⇒ Setting item ②
Set min. differential pressure P1 as "20 in.H <sub>2</sub> O"	⇒ Setting item ⑥
Set max. differential pressure P2 as "120 in.H <sub>2</sub> O"	⇒ Setting item ⑦
Set decimal point position of linear display as "one digit"	⇒ Setting item ⑧
Set OFFSET of linear display as "0.0m"	⇒ Setting item ⑨
Set FULL SCALE of linear display as "50.0m"	⇒ Setting item ⑩
Set output zero point as "0.0%F.S." (0.0m) of max. display span*	⇒ Setting item ⑪
Set output span point as "100.0%F.S." (50.0m) of max. display span*	⇒ Setting item ⑫

\*Maximum display span: OFFSET to FULL SCALE

### ■ Linear display and analog output

Ex. Differential pressure 70 in.H<sub>2</sub>O

- Linear display: 25.0(m)
- Analog output: 12(mA)

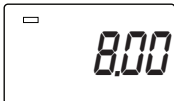
m <sup>(1)</sup>	Differential Pressure (in.H <sub>2</sub> O)	Linear Display (m)	Analog Output (mA)
	120 ⇒	50.0	⇒ 20 Span Point
	∫	∫	∫
	70 ⇒	25.0	⇒ 12
	20 ⇒	0.0	⇒ 4 Zero Point

(1) Put the arbitrary unit sticker.

## 11.4 Flow Measurement/Square Root Extraction Mode

### Square Root Display Mode

Combining the sensing elements (orifice and pitot tube) with this product, the mode is used for the display of the momentary flow rate, integrated volume and for analog output corresponding to the momentary flow rate.

#### (1) Momentary flow rate

Maximum display span from zero to the maximum momentary flow rate. The **Momentary flow rate display span** depends on the setting of the zero point and span point of the analog output as shown in (2) analog output. It can display 0 to 105%F.S. of the momentary flow rate display span. The scaling method can be performed only by setting the maximum momentary flow rate and then generate differential pressure using the following square root formula.

**Momentary flow rate  $D_x$**  is expressed by the square root formula (a), and can be calculated only by measuring the generated differential pressure  $P_x$  (percent value over the differential pressure range).

$$(a) \quad D_x = k \times \sqrt{\frac{P_x(\%)}{100(\%)}}$$

In addition, the coefficient  $k$  is determined by substituting the maximum momentary flow rate  $D_m$ , which is measured from the formula (a), and the then generated differential pressure  $P_m$  into the formula (b).

$$(a) \quad k = \frac{D_m}{\sqrt{\frac{P_m}{100}}}$$

- The **differential pressure generated** during the maximum momentary flow rate can be set in the range of 25 to 100%F.S. of the differential pressure range.
- The setting range for values of the **maximum momentary flow rate** is 0 to 1999. Note: The decimal point can be set arbitrarily.

Setting of max. momentary flow rate and then generated differential pressure $\implies$ Setting item (14), (15), (16)
---

- When the display resolution lowers and the wobbling of momentary flow rate increases in the low flow domain of the differential pressure flow meter, the domain (below the set value) will be forcedly indicated as zero by means of the **low-cut for momentary flow rate**.

Moreover, the analog output has a fixed value of 4mA at the zero point. For setting of low-cut, input the percent value over the maximum display span. Its range is 0 to 30%F.S. and the decimal point position can be set up to one digit after decimal point as fixed point.

Setting of low-cut

⇒ Setting item 17

## (2) Analog output

The zero point (4mA) and span point (20mA) of analog output can be set in the range of 0 to 110%F.S. of the maximum display span (0 to maximum momentary flow rate). The span between the zero point and the span point in this analog output is the momentary flow rate display span.

## (3) Integrated volume

- The **units of integrated volume** include two standards: Time factor and flow rate volume factor.

Setting of integrated volume unit

⇒ Setting item 20, 21

- The **number of digits of integrated volume display** is a maximum of 6 figures (999999); the display will return to 0 once the maximum reading has been met.



- The zero reset of an integrated volume is executed by pressing  $\text{⏏}$  key for more than 3 seconds and displaying "cLr" (clear) for 2 seconds.



- As **backup in case of POWER OFF**, the integrated volume value is stored in the nonvolatile memory for every hour. After power returns, integration starts from the integrated volume value stored in the memory.

- Integration is halted during the "FFF" display **at the time of differential pressure range OVER** (Refer to paragraph 11.5 (1) ).
- The indicated value which is blinking is integrated during the "blink" display **at the time of momentary flow rate display span OVER** (Refer to paragraph 11.5 (2) ).

#### (4) Display switching method of momentary flow rate and integrated volume

Display switching methods of momentary flow rate and integrated volume include the **automatic switching display method** to display them by turns at intervals of fixed time (1 to 10 seconds) and the manual switching display method to change the display by pressing (**M**) key.

Selection of display switching method (automatic or manual)	⇒ Setting item ②
Setting of display switching time for automatic	⇒ Setting item ③

#### ■ Setting example 3: Standard unit for square root display mode

In the differential flow meter whose differential pressure generated at maximum momentary flow rate of 120 is 32IW (80%F.S.) and which uses a differential pressure range of 0 to 40IW, the scaling setting of the momentary flow rate of standard unit and the setting of integrated volume of the standard unit are as follows:

In this case, the low-cut is set as 15%F.S., the display switching method is set as automatic, and the switching time is set as 5 seconds.

Select the "Square root display mode"	⇒ Setting item ②
Set the differential pressure at max. momentary flow rate as 32.0IW (80%F.S.)	⇒ Setting item ⑭
Select "1-digit" as decimal point position of momentary flow rate	⇒ Setting item ⑮
Set the max. momentary flow rate as "120.0."	⇒ Setting item ⑯
Set the low-cut as "15.0%F.S." of max. display span*	⇒ Setting item ⑰
Set the output zero point as "0.0%F.S." (0.0 arbitrary unit of measure) of max. display span*	⇒ Setting item ⑱

- |   |                  |
|---|------------------|
| Set the output span point as "100.0%F.S."<br>(120.0 arbitrary unit of measure) of<br>max. display span* | ⇒ Setting item ⑱ |
| Set time factor selection<br>(seconds, minutes, hours)  | ⇒ Setting item ⑳ |
| Select standard "I" as flow rate volume factor  | ⇒ Setting item ㉑ |
| Select "ti" (automatic) as display<br>switching method  | ⇒ Setting item ㉒ |
| Set automatic display switching time<br>as "5 seconds"  | ⇒ Setting item ㉓ |

\*Maximum display span: 0 to Maximum momentary flow rate

### ■ Arbitrary unit of square root display and analog

Momentary flow rate display (standard)

Outbreak differential pressure: 16IW Integrated volume display (arbitrary unit)

- Second flow quantity: 84.9 Integrated volume 270225  
(Next page reference)

- Analog output: 15.3 mA

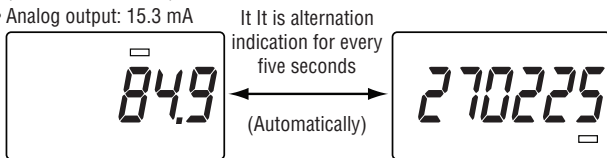

Differential Pressure (IW)	Momentary Flow Rate Unit Span Point	Analog Output (mA)
32	120	20
<b>16</b>	<b>84.9</b>	<b>15.3</b>
0	<b>Zero Point</b> 0	4

## ■ Square Root

The momentary flow rate  $D_x$  at a generated differential pressure of 16IW (40%F.S.) is calculated by the following formula:

The coefficient  $k$  is determined by substituting the maximum momentary flow rate  $D_m=120$  and the then differential pressure  $P_m=80\%$ F.S.(32IW) into the formula (b) of the preceding paragraph 11.4 (1).

$$k = \frac{D_m}{\sqrt{\frac{P_m}{100}}} = \frac{120}{\sqrt{\frac{80}{100}}} = 134.2$$

Therefore, the momentary flow rate  $D_x$  is determined by the formula (a) of the preceding paragraph 11.4(1).

$$D_x = kx \sqrt{\frac{P_x}{100}} = 134.2 \sqrt{\frac{40}{100}} = 84.9$$

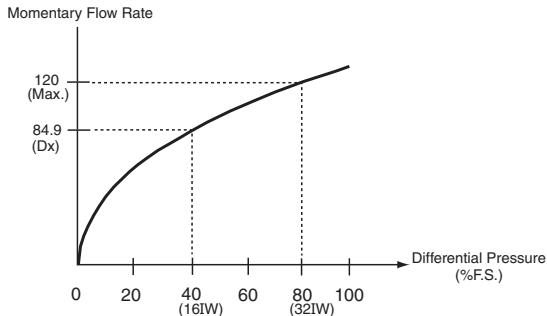

## ■ Setting example 4: Arbitrary unit of square root display mode

### ① Setting of momentary flow rate

In order to set a momentary flow rate to an “arbitrary unit,” the momentary flow rate unit must be set as the arbitrary unit, and the maximum momentary flow rate of the arbitrary unit and the then generated differential pressure must be set.

## ② Setting of integrated volume

When a momentary flow rate unit is set as an arbitrary unit, the integrated volume is also an arbitrary unit and the factor of the two following points must be set:

- Setting of **time factor (second, minute, hour)**
- Setting of **flow factor weight (1, 10, 100, 1000)**

In the differential flow meter whose differential pressure generated at maximum momentary flow rate of 1.000L/s is 16IW (80%F.S.) and which uses a differential pressure range of 0 to 2.0 IW, the setting of momentary flow rate of arbitrary unit and the setting of integrated volume of the arbitrary unit (in order to display 1 per count) are as follows: In this case, the low-cut is set as 10%F.S. and the display switching method is set as manual.

Select the "Square root display mode"	⇒ Setting item ②
Set the differential pressure at max. momentary flow rate as 16IW (80%F.S.)	⇒ Setting item ⑭
Select "3-digit" as decimal point position of momentary flow rate	⇒ Setting item ⑮
Set the max. momentary flow rate as "1.000."	⇒ Setting item ⑯
Set the low-cut as "10.0%F.S." of max. display span*	⇒ Setting item ⑰
Set the output zero point as "0.0%F.S." 0 of max. display span*	⇒ Setting item ⑱
Set the output span point as "100.0%F.S." 1 of max. display span*	⇒ Setting item ⑲
Select "SEC" (second) as time factor of integrated volume	⇒ Setting item ⑳
Select "1" as weight of flow factor of integrated volume	⇒ Setting item ㉑
Select "bt" (manual) as display switching method	⇒ Setting item ㉒

\*Maximum display span: 0 to Maximum momentary flow rate



## ■ Square root display and analog

Momentary flow rate display (arbitrary unit)

Differential pressure: 12IW

Integrated volume display (arbitrary unit)

- Momentary flow rate 0.868

Integrated volume: 570616

- Analog output: 17.9 mA

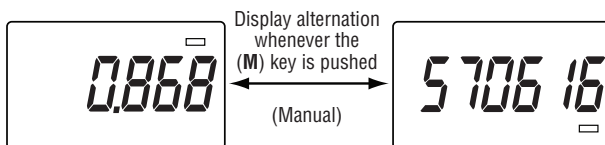

**Differential Pressure (IW)**

16

|

**12**

|

0

**Momentary Flow Rate Unit**

Span Point

1.000

|

**0.868**

|

Zero Point

0

**Analog Output (mA)**

20

|

**17.9**

|

4

---

## 11.5 Out of Range Display

### (1) Range Over display

In the Measurement Mode, if the pressure is below  $-15\%$  F.S. (URL) “-FFF” will be displayed, and if it is more than  $115\%$ F.S., “FFF” will be displayed.

### (2) Span Over display

When the user has adjusted the span of the device this case will apply. The display range in each display mode is  $-5$  to  $105\%$ F.S. of the display span. When this range is exceeded, the value of  $-5\%$ F.S. or  $105\%$ F.S. will be held (depending upon whether unit is below or above the span values) in a blinking state.

### (3) Analog output

The analog output is linked with the display and is at  $3.2\text{mA}$  when the display span is at or exceeded  $-5\%$ F.S. and at  $20.8\text{mA}$  when the display span is at or greater than  $105\%$ F.S.

## ■ Out of Range Display

Differential pressure mode (Differential pressure range  $0$  to  $20\text{in.H}_2\text{O}$ )

Pressure display span  $20\text{in.H}_2\text{O}$ )

Span point:  $2000$

Zero point:  $000$

- Overage display

- Overage display

-15%F.S. (-3.0 inH<sub>2</sub>O) more/less

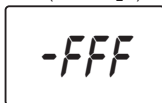

115%F.S. (23.0 inH<sub>2</sub>O) more/less



- Span over display

- 5%F.S. (-1.0 inH<sub>2</sub>O) more/less



105%F.S. (21.0 inH<sub>2</sub>O) more/less



## 12. ZERO ADJUSTMENT MODE

In the measurement mode, the pressure connection (H, L) is open to the atmosphere and  key is pressed for more than 3 seconds in order to shift to zero adjustment mode (refer to section 11) for zero point adjustment of the differential pressure sensor.

- If the zero point adjustment is correctly performed, the message "AdJ" will be displayed for 2 seconds, and the display will return to the measurement mode.
- If zero point correction is performed when the applied pressure is over  $\pm 10\%$ F.S., the error message "E-0" will be displayed for 2 seconds, and the display will return to the measurement mode without completing the zero point adjustment.

- Normal Message -



- Error Message -

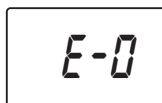

**CAUTION:** Only perform the zero point correction when both the H and L ports are open to the atmosphere. If done incorrectly the accuracy of the device may be effected.

### 13. KEY LOCK

Function	Key Manual	Indicator
Setting of key lock	MODE+▲ one second	LoC
Release of key lock	MODE+▲ one second	UnL

Operation during keylock

Function	Key Manual	Indicator
Zero adjust. mode	▲ key greater than 3 sec.	LoC (Key invalidity)
Hold value reset	▼ key greater than 3 sec.	LoC (Key invalidity)

### 14. SETTING MODE

The setting modes include differential pressure display mode setting, linear display mode setting, and flow measurement/square root mode setting. In addition, loop check (refer to section 14.5) can be performed in each mode setting.

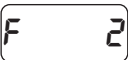

For the setting procedure of each display mode, refer to paragraphs 14.3 and 14.4.

- 14.1 List of Setting Items for Differential Pressure Display Mode**  
(Re-scaling in "inH<sub>2</sub>O" units). Set the filter before setting the differential pressure setting mode. See page 24 for full menu.

No.	Setting Item	LCD Display	Setting Description	Setting Range	Default*
①	Filter		Selection of moving average time of differential pressure: 2 (sec)	0,2,4,8,16,sec	4

\*The factory default.

The setting of the following table is the Setting example 1: pressure display mode of Section 11-2. This applies when re-scaling in “inH<sub>2</sub>O” units. See Section 14.4 for full menu.

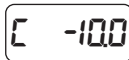
No.	Setting Item	LCD Display	Setting Description	Setting Range	Default
②	Display mode		Selection of differential pressure display mode: non	non: Differential pressure display mode Lin: Linear display mode	non
③	Output zero point <sup>(1)</sup>		Differential pressure of analog output zero point 4mA: -10.0(%F.S.)	Differential pressure range: -10 to 110%F.S.	0.0
④	Output span point <sup>(1)</sup>		Differential pressure of analog output span point (20mA): 90.0(%F.S.)	Differential pressure range: -10 to 110%F.S.	100.0
⑤	Loop check <sup>(2)</sup>		Arbitrary change of differential pressure display and analog output: -10.00 (psi.)	Display: Differential pressure display span; Analog output: 4 to 20mA	0.0 (4.00 mA)

(1) For setting of zero point and span point in the analog output, input the percent value over the differential pressure range.

(2) Regardless of generated differential pressure, the loop check can be changed by arbitrarily linking the pressure display with the analog output using ▲, ▼ key. (Refer to Section 14.3). This example of LCD display shows the zero point display at the time of loop check start.

**14.2 Setting Items for Linear Display Mode** (Re-scaling in arbitrary user defined units) Set the filter before setting the linear display mode (Refer to the preceding Section 11.1). The setting of the following table is the Setting example 2: Linear display mode of Section 11.3. (Arbitrary unit: m). This applies when re-scaling in arbitrary user defined units. See Section 14.4 for full menu.

No	Setting Item	LCD Display	Setting Description	Setting Range	Default
②	Display mode		Selection of linear display mode: Lin	non: Differential pressure display mode; Lin: Linear display mode	non
⑥	Min. differential pressure <sup>(1)</sup>		Min. differential pressure corresponding to OFF-SET (⑨):20.0(inH <sub>2</sub> O)	Differential pressure range: 0 to 75%F.S.	0.0
⑦	Max. differential pressure <sup>(1)</sup>		Max. differential pressure corresponding to FULL SCALE (⑩):120inH <sub>2</sub> O	Differential pressure range: 25 to 100%F.S.	100.0
⑧	Decimal point position		Display after decimal point Number of digits:1 (digit)	0,1,2,3 digit	0
⑨	OFFSET		OFFSET corresponding min. differential pressure (⑥): 0.0 (m)	-1999 to 1999	0
⑩	FULL SCALE		FULL SCALE corresponding to max. differential pressure (⑦):50.0 (m)	-1999 to 1999	1000
⑪	Output zero point <sup>(2)</sup>		Analog output zero point : (4mA): 0.0 (%F.S.)	Max. display span: -10 to 110%F.S.	0.0
⑫	Output span point <sup>(2)</sup>		Analog output span point : (20mA): 100.0 (%F.S.)	Max. display span: -10 to 110%F.S.	100.0
⑬	Loop check <sup>(3)</sup>		Arbitrary change of linear display and analog output: 50.0 (m), 20mA	Display: Linear display span; Analog output: 4 to 20mA	0 (4.0mA)

- (1) The decimal point position is fixed for each differential pressure range. (Refer to section 10, Power-on Message).  
The max. differential pressure can be set from the value which is 25%F.S above the minimum differential pressure. The values under 25%F.S. cannot be increased or decreased by , key.
- (2) For setting zero point and span point of the analog output, input the percent value over the maximum display span (between OFFSET and FULL SCALE). Its decimal point position can be set up to one digit after the decimal point (xx.x).
- (3) Regardless of whether pressure is applied or not, the loop check can be activated which links the display and the output allowing the operator to arbitrarily adjust the output to check the system, troubleshoot etc (using the , keys), ref section 14.4. This example shows the display set to the span point.

### 14.3 Flow Measurement/Square Root Extraction Mode

No.	Setting Item	LCD Display	Setting Description	Setting Range	Default
②	Display mode	$\bar{n}$ rot	Selection for flow measurement/ square root extraction mode	<b>non</b> : Differential pressure display mode <b>Lin</b> : Linear display mode <b>Rot</b> : Square root display mode	non
⑭	Maximum differential selection <sup>1</sup>	P. 400	Maximum differential pressure relating to the flow rate	25 to 100% F.S. of sensor range	100.0% of sensor range
⑮	Flow rate decimal pt. position	d 0	Displays of value after decimal point, # of digits	0,1,2,3 digit	0
⑯	Max. momentary flow	d 1000	Max. momentary of flow using arbitrary units	0 to 1999	1000
⑰	Low cut	L 0.0	Forces display and output to zero	0.0 to 30.0% F.S. of max. display span	0.0
⑱	Output zero point <sup>2</sup>	R 0.0	Momentary flow rate of analog output zero point (4mA): 100.0% F.S.	-10 to 100% F.S. of max. display span	0.0
⑲	Output span point <sup>2</sup>	R 100.0	Momentary flow rate of analog output zero point (20mA): 100.0% F.S.	-10 to 100% F.S. of max. display span	100.0
⑳	Time factor	U SEC	Measurement of max. momentary flow rate over time selected	Seconds, minutes or hours	Sec
㉑	Flow rate volume factor	U 1	Flow rate x time selected	1,10,100,1000	1
㉒	Display switch setting	S bt	Selection of display switching method of momentary flow rate and integrated volume	ti = automatic bt = manual	bt
㉓	Switch time interval	t 5	Selection for ti: automatic Displays switching time interval in seconds	1 to 10 seconds (10 stage)	5
㉔	Loop check <sup>3</sup>	c 0.0	Output check using arbitrary value – displays pressure correlating to the 4 to 20mA signal	Display: momentary flow rate display span Analog output: 4 to 20mA 0.0 to 100.0%	0 (4.0mA)

- (1) In the setting of a differential pressure the decimal point position is fixed for each differential pressure range. (Refer to paragraph 12, Power-on Message). The max. differential pressure can be set from the value which is 25%F.S of the differential pressure range above the minimum differential pressure. The values under 25%F.S. cannot be increased or decreased by  $\odot$ ,  $\ominus$  key.
- (2) For setting zero point and span point of the analog output, input the percent value over the maximum display span (between OFFSET and FULL SCALE). Its decimal point position can be set up to one digit after the decimal point (xx.x).
- (3) Regardless of generated differential pressure or low-cut, the loop check can be changed arbitrarily linking the momentary flow rate display with the analog output using the  $\odot$ ,  $\ominus$  keys. (Refer to 14.5.) This example of LCD display shows the display set to span point.

## 14.4 Setting Procedure (Setting Examples from 14.1, 14.2)

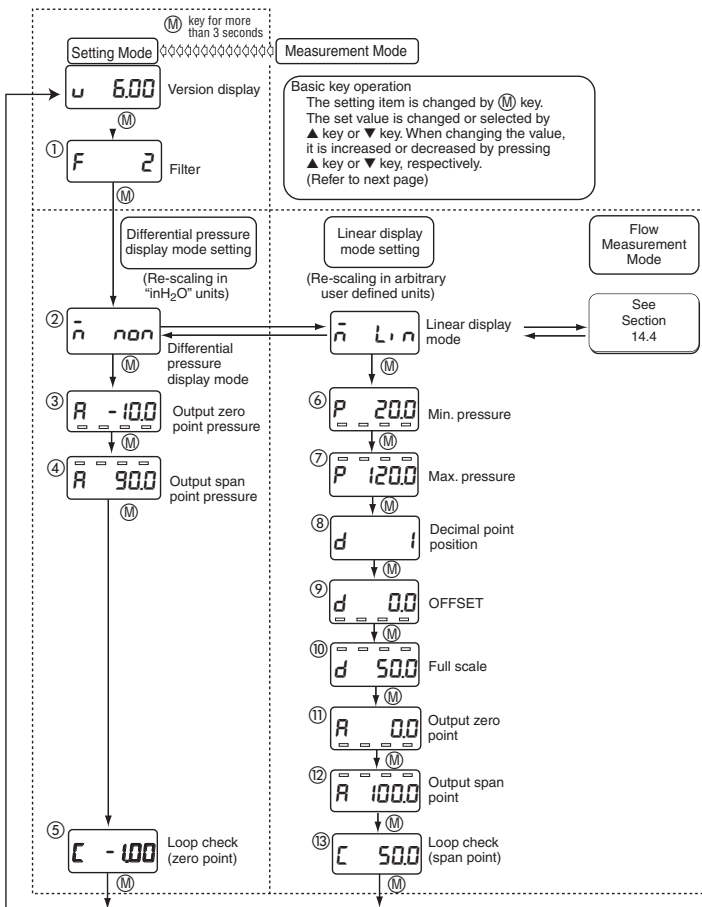



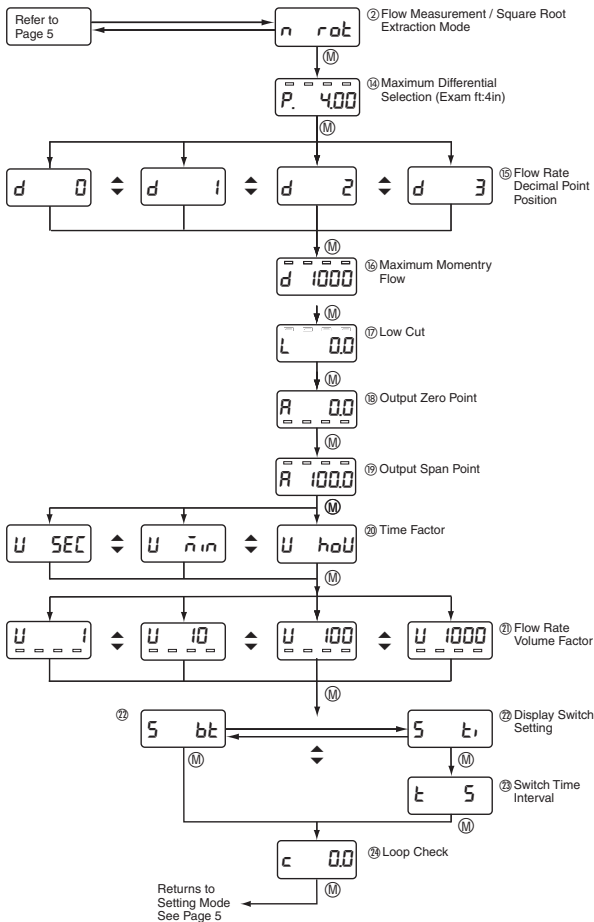

## 14.5 Loop Check

In each display mode, regardless of applied pressure, the loop check can be changed by arbitrarily linking the display with the analog output using the key operation. The display will show representative pressure readings correlating to the 4-20mA signal.

### ■ Loop check method

- (1) Remove the lid of this product.
- (2) Shift to either the differential pressure, linear display or flow measurement modes. (See Section 14). Use (M) button to scroll to Loop Check function as indicated within Section 14.1, 14.2 or 14.3 respectively. The display and output (4mA) are at the zero point when loop check starts.
- (3) If the  $\odot$  is pressed, the display will increase along with the output. By pressing  $\ominus$  key, decrease will occur. Release the key at the desired indication. For example, if the key is released at 25.0m, the display will stop and be held at analog output 12mA corresponding to the indication, ref. example from section 14.2

### ■ Analog Output Check Terminals

When the front cover is removed, the analog output check terminals (pad: CH+, CH-) are visible at the upper part of the display substrate. The analog output can be checked during measurement mode or loop check by applying a probe, such as a tester for current measurement, onto the check terminal of the substrate, as shown in the following figure. In addition, receivers are not affected by the tester's probes.

#### Loop check / linear display

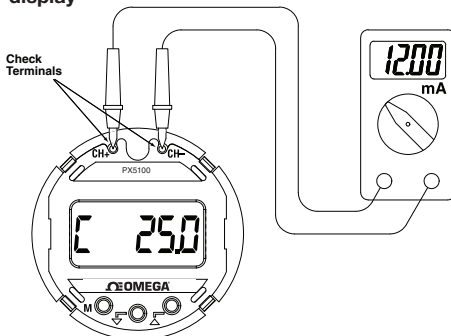

## 15. DIMENSION DRAWINGS

Dimensions in inches

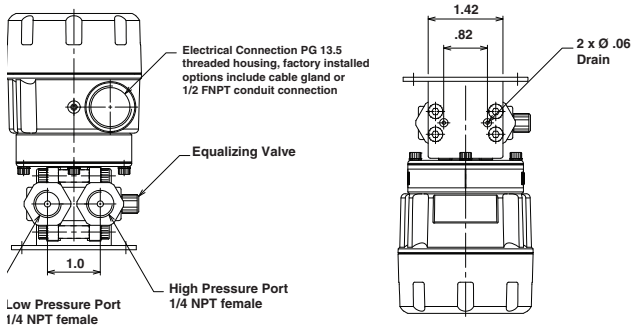
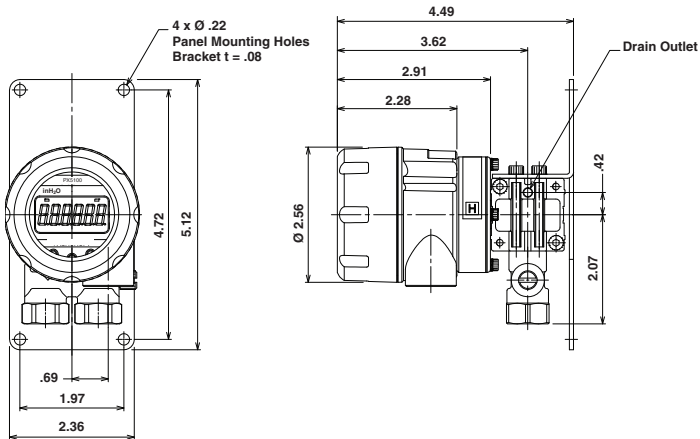

---

## 16. MAINTENANCE AND WARRANTY

### ■ Periodic inspection

Depending upon the type of use periodic inspection is recommended at least once a year. Please refer to the following items for periodic inspection.

- (1) Appearance
- (2) Display/output check via appropriate pressure standard<sup>(1)</sup>
- (3) Display/output check via Loop Check<sup>(2)</sup>

### ■ CAUTION

- Avoid electrostatic charging. When cleaning this product, please use a soft, damp, cloth.
- Do not use thinner, etc. which may cause deterioration and failure.

### ■ Product warranty

Except as otherwise provided, the product warranty of this product is as follows:

Period: 12 months after delivery

Warrantable defects: Defects resulting from the design and manufacture of our company, the quality of the material, etc.

Implementation of warranty: This warranty will be completed by substitution or repair of the product concerned.

We will not take responsibility for consequential damages caused by product defects.

- If you have any questions about this document, please contact the sales office or distributor nearest you.
- This document is subject to change without notice due to upgrade etc.

(1) If zero correction is required refer to section 12.

(2) Loop check, see section 14.5.

---

---

---

---

## WARRANTY/DISCLAIMER

OMEGA ENGINEERING, INC. warrants this unit to be free of defects in materials and workmanship for a period of **13 months** from date of purchase. OMEGA's Warranty adds an additional one (1) month grace period to the normal **one (1) year product warranty** to cover handling and shipping time. This ensures that OMEGA's customers receive maximum coverage on each product.

If the unit malfunctions, it must be returned to the factory for evaluation. OMEGA's Customer Service Department will issue an Authorized Return (AR) number immediately upon phone or written request. Upon examination by OMEGA, if the unit is found to be defective, it will be repaired or replaced at no charge. OMEGA's WARRANTY does not apply to defects resulting from any action of the purchaser, including but not limited to mishandling, improper interfacing, operation outside of design limits, improper repair, or unauthorized modification. This WARRANTY is VOID if the unit shows evidence of having been tampered with or shows evidence of having been damaged as a result of excessive corrosion; or current, heat, moisture or vibration; improper specification; misapplication; misuse or other operating conditions outside of OMEGA's control. Components in which wear is not warranted, include but are not limited to contact points, fuses, and triacs.

**OMEGA is pleased to offer suggestions on the use of its various products. However, OMEGA neither assumes responsibility for any omissions or errors nor assumes liability for any damages that result from the use of its products in accordance with information provided by OMEGA, either verbal or written. OMEGA warrants only that the parts manufactured by the company will be as specified and free of defects. OMEGA MAKES NO OTHER WARRANTIES OR REPRESENTATIONS OF ANY KIND WHATSOEVER, EXPRESSED OR IMPLIED, EXCEPT THAT OF TITLE, AND ALL IMPLIED WARRANTIES INCLUDING ANY WARRANTY OF MERCHANTABILITY AND FITNESS FOR A PARTICULAR PURPOSE ARE HEREBY DISCLAIMED. LIMITATION OF LIABILITY: The remedies of purchaser set forth herein are exclusive, and the total liability of OMEGA with respect to this order, whether based on contract, warranty, negligence, indemnification, strict liability or otherwise, shall not exceed the purchase price of the component upon which liability is based. In no event shall OMEGA be liable for consequential, incidental or special damages.**

CONDITIONS: Equipment sold by OMEGA is not intended to be used, nor shall it be used: (1) as a "Basic Component" under 10 CFR 21 (NRC), used in or with any nuclear installation or activity; or (2) in medical applications or used on humans. Should any Product(s) be used in or with any nuclear installation or activity, medical application, used on humans, or misused in any way, OMEGA assumes no responsibility as set forth in our basic WARRANTY/DISCLAIMER language, and, additionally, purchaser will indemnify OMEGA and hold OMEGA harmless from any liability or damage whatsoever arising out of the use of the Product(s) in such a manner.

## RETURN REQUESTS/INQUIRIES

Direct all warranty and repair requests/inquiries to the OMEGA Customer Service Department. BEFORE RETURNING ANY PRODUCT(S) TO OMEGA, PURCHASER MUST OBTAIN AN AUTHORIZED RETURN (AR) NUMBER FROM OMEGA'S CUSTOMER SERVICE DEPARTMENT (IN ORDER TO AVOID PROCESSING DELAYS). The assigned AR number should then be marked on the outside of the return package and on any correspondence. The purchaser is responsible for shipping charges, freight, insurance and proper packaging to prevent breakage in transit.

FOR **WARRANTY** RETURNS, please have the following information available BEFORE contacting OMEGA:

1. Purchase Order number under which the product was PURCHASED,
2. Model and serial number of the product under warranty, and
3. Repair instructions and/or specific problems relative to the product.

FOR **NON-WARRANTY** REPAIRS, consult OMEGA for current repair charges. Have the following information available BEFORE contacting OMEGA:

1. Purchase Order number to cover the COST of the repair,
2. Model and serial number of the product, and
3. Repair instructions and/or specific problems relative to the product.

OMEGA's policy is to make running changes, not model changes, whenever an improvement is possible. This affords our customers the latest in technology and engineering.

OMEGA is a registered trademark of OMEGA ENGINEERING, INC.

© Copyright 2017 OMEGA ENGINEERING, INC. All rights reserved. This document may not be copied, photocopied, reproduced, translated, or reduced to any electronic medium or machine-readable form, in whole or in part, without the prior written consent of OMEGA ENGINEERING, INC.

# Where Do I Find Everything I Need for Process Measurement and Control? **OMEGA...Of Course!**

*Shop online at [omega.com](http://omega.com)<sup>SM</sup>*

## **TEMPERATURE**

- ☑ Thermocouple, RTD & Thermistor Probes, Connectors, Panels & Assemblies
- ☑ Wire: Thermocouple, RTD & Thermistor
- ☑ Calibrators & Ice Point References
- ☑ Recorders, Controllers & Process Monitors
- ☑ Infrared Pyrometers

## **PRESSURE, STRAIN AND FORCE**

- ☑ Transducers & Strain Gages
- ☑ Load Cells & Pressure Gages
- ☑ Displacement Transducers
- ☑ Instrumentation & Accessories

## **FLOW/LEVEL**

- ☑ Rotameters, Gas Mass Flowmeters & Flow Computers
- ☑ Air Velocity Indicators
- ☑ Turbine/Paddlewheel Systems
- ☑ Totalizers & Batch Controllers

## **pH/CONDUCTIVITY**

- ☑ pH Electrodes, Testers & Accessories
- ☑ Benchtop/Laboratory Meters
- ☑ Controllers, Calibrators, Simulators & Pumps
- ☑ Industrial pH & Conductivity Equipment

## **DATA ACQUISITION**

- ☑ Communications-Based Acquisition Systems
- ☑ Data Logging Systems
- ☑ Wireless Sensors, Transmitters, & Receivers
- ☑ Signal Conditioners
- ☑ Data Acquisition Software

## **HEATERS**

- ☑ Heating Cable
- ☑ Cartridge & Strip Heaters
- ☑ Immersion & Band Heaters
- ☑ Flexible Heaters
- ☑ Laboratory Heaters

## **ENVIRONMENTAL MONITORING AND CONTROL**

- ☑ Metering & Control Instrumentation
- ☑ Refractometers
- ☑ Pumps & Tubing
- ☑ Air, Soil & Water Monitors
- ☑ Industrial Water & Wastewater Treatment
- ☑ pH, Conductivity & Dissolved Oxygen Instruments