

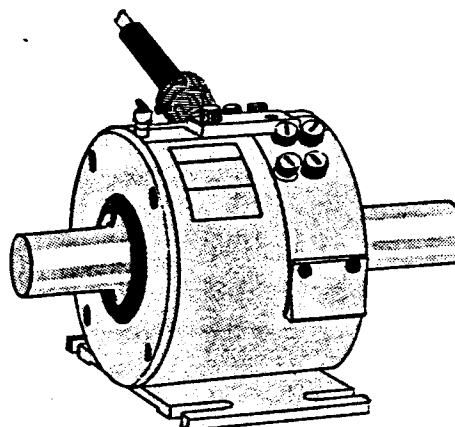

TQ501 Rotary Torque Sensor

M1460/0592



GENERAL DESCRIPTION

The OMEGA TQ501 Rotary Torque Sensor is ideal for measuring torques in rotating shafts. An integral slip ring assembly is used to transfer the electrical signal from rotating electronics to stationary electronics. The slip ring consists of silver graphite brushes which rub on the rotating ring, providing an electrical path for the incoming excitation and the outgoing signal voltage. Because of the low signal levels produced by a strain gage bridge, brushes should be periodically cleaned. For long term measurements, the brushes can be replaced.

HOW TORQUE SENSORS WORK

Torque sensors have an output or sensitivity in mV/V. What this sensitivity/output represents is as follows:

Change in Millivolt output from zero load to the full scale capacity of the sensor (21.3 mV in this example) = Output/Sensitivity (example 2.13 mV/V) x Excitation (10.0 VDC)

Torque sensors rarely have exactly zero millivolts at no load. Most sensors have a small DC offset of a few millivolts, which is normal. To scale a system, the end-user simply scales the recorder/meter for a full scale range, then connects the torque sensor.

AVAILABLE MODELS

MODEL	RANGE
TQ501-100	0 - 100 in-lb
TQ501-200	0 - 200 in-lb
TQ501-500	0 - 500 in-lb
TQ501-1K	0 - 1,000 in-lb
TQ501-2K	0 - 2,000 in-lb
TQ501-5K	0 - 5,000 in-lb
TQ501-10K	0 - 10,000 in-lb

INSTALLATION INSTRUCTIONS

While the TQ501 Rotary Torque Sensor is a very rugged device, it should not be subjected to torsional loads in excess of 150% of it's rated capacity. The sensor can be used to measure torque in both clockwise and counterclockwise directions. When alternating clockwise and counterclockwise torsional loads are applied to the sensor, there should be no play in either loading direction.

NOTE: The TQ501 sensor is not designed to take off-axis loading. It is very important to have the proper shaft couplings installed in your system.

DIMENSIONS (INCHES)

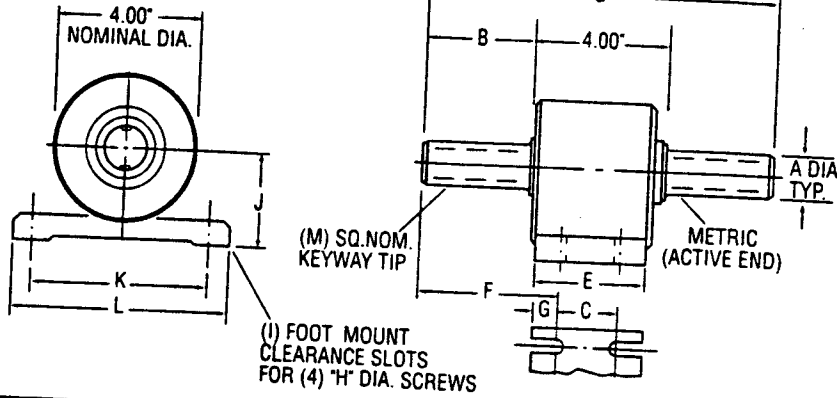

Model No.	A +.000 -.003	B	C	D	E	F	G	H	J +.000 -.010	K	L	M
TQ501-100	.750	2.25	1.56	8.50	3.26	3.26	0.86	14	2.125	4.000	4.75	3/16
TQ501-200												
TQ501-500												
TQ501-1K	1.000											1/4
TQ501-2K												
TQ501-5K	1.500	2.75	2.02	9.50	3.50	3.64	0.74	3/8	2.500	5.250	6.25	3/8
TQ501-10K												

GENERAL CALIBRATION PROCEDURE

The sensor is cycled through the operating range to develop a stable hysteresis loop. Known loads are then applied to the sensor by means of dead weights or a reference load cell in ascending and descending increments. The data recorded is then best fit to second degree equations which describe ascending, descending, and average calibration curves. These equations are incrementally solved to generate theoretical sensor outputs at various loads. The calibration sheet supplies you with these data points and their meanings are defined in the following diagram:

SENSOR CALIBRATION
(CURVATURE EXAGGERATED)

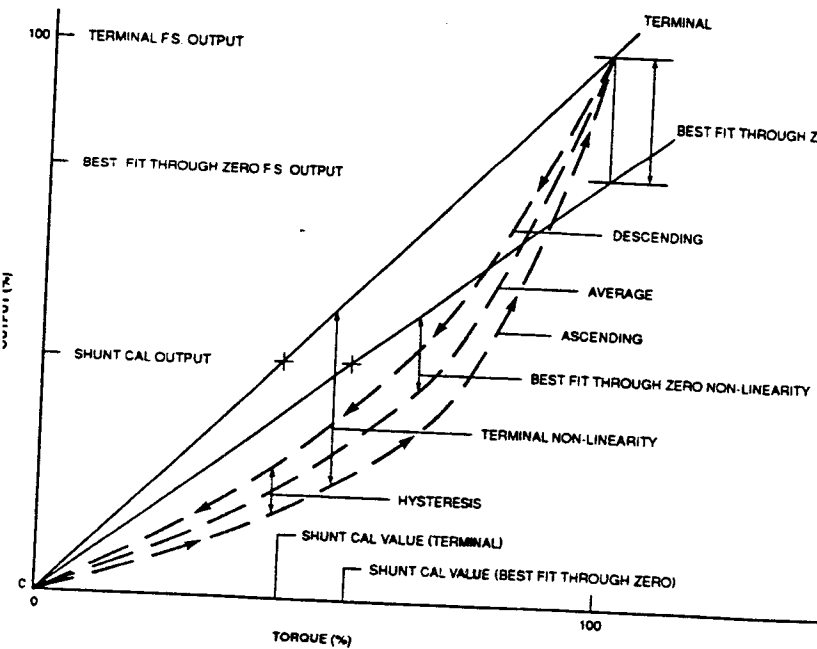

Terminal Non-linearity (N/L): computed from deviations of ascending theoretical data from a straight line connecting the zero and full scale points.

Terminal hysteresis (HYS): computed from the differences between descending and ascending theoretical data.

Best fit through zero Non-linearity (BF/0): computed from deviations of average theoretical data from a straight line through zero with a slope which produces minimum deviations with average theoretical data.

Best fit through zero outputs and best fit through zero shunt cal values should be used when the sensor is assumed to be linear. If the instrumentation is capable of correcting second order non-linearity, the average outputs and shunt cal output values should be used.

WIRING

PIN A: + EXCITATION
PIN B: + SIGNAL
PIN C: - SIGNAL
PIN D: - EXCITATION

NIST TRACEABILITY

The TQ501 sensor is calibrated using a known load (applied to an NIST traceable load cell) through a known distance (measured by an NIST traceable lever arm). This set-up is considered a tertiary standard, traceable to NIST.

SPECIFICATIONS

RATED OUTPUT:	2 mV/V nominal
EXCITATION:	10 Vdc, 20 Vdc maximum
ACCURACY:	0.18% F.S.
LINEARITY:	0.10% F.S.
HYSTERESIS:	0.10% F.S.
REPEATABILITY:	0.10% F.S.
ZERO BALANCE:	1.0% F.S.
OPERATING TEMP. RANGE:	-65°F to 250°F
COMPENSATED TEMP. RANGE:	70°F to 170°F
THERMAL EFFECTS	
Zero:	0.002% F.S./°F
Span:	0.002% Rdg./°F
MAX. LOAD	
Safe:	150% F.S.
Ultimate:	300% F.S.
BRIDGE RESISTANCE:	350 ohms nominal
FULL SCALE ANGULAR DEFLECTION:	1.2 degrees
CONSTRUCTION:	Nickel plated steel
ELECTRICAL:	Mating connector supplied
WEIGHT:	8 lbs. (3.6 kg)

Servicing USA and Canada: Call OMEGA Toll Free

OMEGA Engineering, Inc.

One Omega Drive, Box 4047

Stamford, CT 06907-0047 U.S.A.

Headquarters: (203) 359-1660

Sales: 1-800-826-6342 / 1-800-TC-OMEGA

Customer Service: 1-800-622-2378 / 1-800-622-BEST

Engineering: 1-800-872-9436 / 1-800-USA-WHEN

FAX: (203) 359-7700 TELEX: 996404 EASYLINK: 62968934 CABLE: OMEGA

Servicing Europe: United Kingdom Sales and Distribution Center

OMEGA Technologies Ltd.

P.O. Box 1, Broughton Astley, Leicestershire

LE9 6XR, England

Telephone: (0455) 285520 FAX: (0455) 283912

WARRANTY

OMEGA warrants this unit to be free of defects in materials and workmanship and to give satisfactory service for a period of **13 months** from date of purchase. OMEGA Warranty adds an additional one (1) month grace period to the normal **one (1) year product warranty** to cover handling and shipping time. This ensures that our customers receive maximum coverage on each product. If the unit should malfunction, it must be returned to the factory for evaluation. Our Customer Service Department will issue an Authorized Return (AR) number immediately upon phone or written request. Upon examination by OMEGA, if the unit is found to be defective, it will be repaired or replaced at no charge. However, this WARRANTY is VOID if the unit shows evidence of being damaged as a result of excessive corrosion; or current, heat, moisture, vibration, or other operating conditions outside of OMEGA's control. Components that wear or wear out or are damaged by misuse are not warranted. These include contact points, fuses, and triacs.

We are glad to offer suggestions on the use of our various products. Nevertheless OMEGA only warrants that the parts manufactured by it will be as specified and free of defects.

OMEGA MAKES NO OTHER WARRANTIES OR REPRESENTATIONS OF ANY KIND WHATSOEVER, EXPRESSED OR IMPLIED, EXCEPT THAT OF TITLE AND ALL IMPLIED WARRANTIES INCLUDING ANY WARRANTY OF MERCHANTABILITY AND FITNESS FOR A PARTICULAR PURPOSE ARE HEREBY DISCLAIMED.

LIMITATION OF LIABILITY: The remedies of buyer set forth herein are exclusive and the total liability of OMEGA with respect to this order, whether based on contract, warranty, negligence, indemnification, strict liability or otherwise, shall not exceed the purchase price of the component upon which liability is based. In no event shall OMEGA be liable for consequential, incidental or special damages.

Every precaution for accuracy has been taken in the preparation of this manual, however, OMEGA ENGINEERING, INC. neither assumes responsibility for any omissions or errors that may appear nor assumes liability for any damages that result from the use of the products in accordance with the information contained in the manual.

RETURN REQUESTS / INQUIRIES

Direct all warranty and repair requests/inquiries to the OMEGA ENGINEERING Customer Service Department. Call toll free in the USA and Canada: 1-800-622-2378, FAX: 203-359-7811; International: 203-359-1660, FAX: 203-359-7807.

BEFORE RETURNING ANY PRODUCT(S) TO OMEGA, YOU MUST OBTAIN AN AUTHORIZED RETURN (AR) NUMBER FROM OUR CUSTOMER SERVICE DEPARTMENT (IN ORDER TO AVOID PROCESSING DELAYS). The assigned AR number should then be marked on the outside of the return package and on any correspondence.

FOR WARRANTY RETURNS, please have the following information available BEFORE contacting OMEGA:

1. P.O. number under which the product was PURCHASED,
2. Model and serial number of the product under warranty, and
3. Repair instructions and/or specific problems you are having with the product.

FOR NON-WARRANTY REPAIRS OR CALIBRATION, consult OMEGA for current repair / calibration charges. Have the following information available BEFORE contacting OMEGA:

1. Your P.O. number to cover the COST of the repair / calibration,
2. Model and serial number of the product, and
3. Repair instructions and/or specific problems you are having with the product.

OMEGA's policy is to make running changes, not model changes, whenever an improvement is possible. That way our customers get the latest in technology and engineering.

OMEGA is a registered trademark of OMEGA ENGINEERING, INC.

© Copyright 1992 OMEGA ENGINEERING, INC. All rights reserved including illustrations. Nothing in this manual may be reproduced in any manner, either wholly or in part for any purpose whatsoever without written permission from OMEGA ENGINEERING, INC. Printed in U.S.A.