

# User's Guide



*Shop online at*

**omega.com<sup>®</sup>**

Ω OMEGA<sup>®</sup>

*omega.com*

*e-mail: info@omega.com*

*For latest product manuals:*

*omegamanual.info*

**ISO 9001**  
CERTIFIED  
CORPORATE QUALITY

STAMFORD, CT

**ISO 9002**  
CERTIFIED  
CORPORATE QUALITY

MANCHESTER, UK

## **LVU30 Series Ultrasonic Sensors Serial Communication Guide**



**OMEGAnet® Online Service**  
**omega.com**

**Internet e-mail**  
**info@omega.com**

### **Servicing North America:**

**U.S.A.:** One Omega Drive, P.O. Box 4047  
ISO 9001 Certified Stamford, CT 06907-0047  
TEL: (203) 359-1660  
FAX: (203) 359-7700  
e-mail: info@omega.com

**Canada:** 976 Bergar  
Laval (Quebec) H7L 5A1, Canada  
TEL: (514) 856-6928  
FAX: (514) 856-6886  
e-mail: info@omega.ca

### **For immediate technical or application assistance:**

**U.S.A. and Canada:** Sales Service: 1-800-826-6342/1-800-TC-OMEGA®  
Customer Service: 1-800-622-2378/1-800-622-BEST®  
Engineering Service: 1-800-872-9436/1-800-USA-WHEN®

**Mexico:** En Español: (001) 203-359-7803  
e-mail: espanol@omega.com  
FAX: (001) 203-359-7807  
info@omega.com.mx

### **Servicing Europe:**

**Czech Republic:** Frystatska 184, 733 01 Karviná, Czech Republic  
TEL: +420 (0)59 6311899  
FAX: +420 (0)59 6311114  
Toll Free: 0800-1-66342  
e-mail: info@omegashop.cz

**Germany/Austria:** Daimlerstrasse 26, D-75392 Deckenpfronn, Germany  
TEL: +49 (0)7056 9398-0  
FAX: +49 (0)7056 9398-29  
Toll Free in Germany: 0800 639 7678  
e-mail: info@omega.de

**United Kingdom:** One Omega Drive, River Bend Technology Centre  
ISO 9002 Certified Northbank, Irlam, Manchester  
M44 5BD United Kingdom  
TEL: +44 (0)161 777 6611  
FAX: +44 (0)161 777 6622  
Toll Free in United Kingdom: 0800-488-488  
e-mail: sales@omega.co.uk

---

It is the policy of OMEGA Engineering, Inc. to comply with all worldwide safety and EMC/EMI regulations that apply. OMEGA is constantly pursuing certification of its products to the European New Approach Directives. OMEGA will add the CE mark to every appropriate device upon certification. The information contained in this document is believed to be correct, but OMEGA accepts no liability for any errors it contains, and reserves the right to alter specifications without notice.  
**WARNING:** These products are not designed for use in, and should not be used for, human applications.

# Table of Contents

1.0 Introduction.....	3
2.0 Sensor Wiring .....	3
3.0 Communications Protocol .....	3
4.0 Sensor Commands.....	4-8
4.1 Request for STATUS from the LVU30 Series .....	4
4.2 Response from LVU30 Series when STATUS information is requested .....	4
4.3 Request to WRITE to the LVU30 Series Data Memory .....	5
4.4 Request to READ from the LVU30 Series Data Memory .....	6
4.5 Response from the LVU30 Series to a READ request of Data Memory.....	6
4.6 Request to SOFTWARE TRIGGER the LVU30 Series .....	7
4.7 Request for LVU30 Series MODEL TYPE and FIRMWARE REVISION LEVEL.....	7
4.8 Response from the LVU30 Series when requesting MODEL TYPE and FIRMWARE REV. 7	
4.9 Response from the LVU30 Series on a SENSOR ERROR.....	8
4.10 Resetting an LVU30 Series ERROR .....	8
4.11 Request to REBOOT the LVU30 Series.....	8
5.0 LVU30 Series Data Memory .....	9-13
5.1 LVU30 Series Data Memory (General) .....	9-10
5.2 LVU30 Series Data Memory (Linear Mode Parameters).....	11
5.3 LVU30 Series Data Memory (Switch Mode Parameters).....	12
5.4 LVU30 Series Data Memory (Sensitivity Adjustment Parameters).....	13
6.0 Flowcharts .....	14-17
LVU30 Series Flowchart for Status Information on Multiple Sensors.....	14
LVU30 Series Flowchart for Writing to Data Memory .....	15
LVU30 Series Flowchart for Reading Data Memory.....	16
LVU30 Series Flowchart for Error Processing.....	17

*This document contains proprietary information which is protected by copyright. All rights are reserved. No part of this document may be photocopied, reproduced, or translated without the prior written consent of Omega Engineering, Inc.*

*All specifications are subject to change without notice.*

# 1 Introduction

---

This document was developed for users who want to communicate and control the LVU30 Series Ultrasonic Sensors with their own host device. The following pages describe how to obtain Sensor Status information and how to access Data Memory, which controls the sensors operation. Flowcharts in the back of the guide include how to develop routines to implement 32 sensors on line and error handling. Throughout this guide, the term LVU30 Series will mean the line of LVU30 Series Smart Sensors.

# 2 Sensor Wiring

---

A wiring diagram using an RS232 (DB9) to RS485 Converter is shown below. You can also use a USB to RS485 Converter if your PC does not have a RS232 communications port.

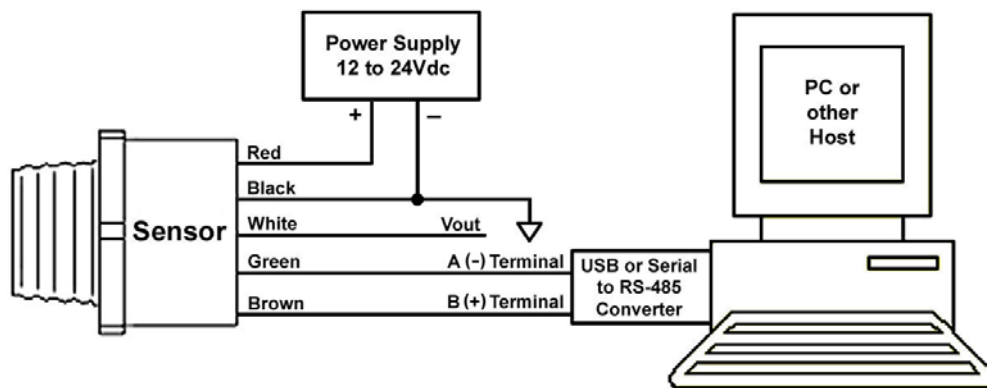

# 3 Communications Protocol

---

The data rate is set at 19.2 kbaud. Each byte contains 10 bits that include a start bit, 8 bit data, and 1 stop bit and no parity bit. There are a total of 6 bytes required to access the LVU30 Series. The LVU30 Series will respond back with 6 bytes that include status (range to target, temperature, target strength, etc), Data Memory read requests, and sensor error messages on the RS485 bus. Transmitted values are in binary.

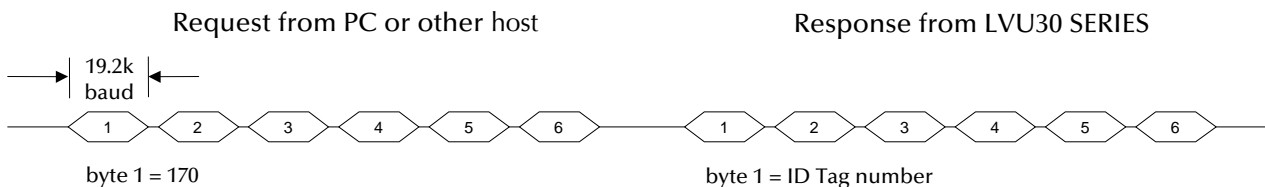

## 4 Sensor Commands

### 4.1 Request for STATUS from the LVU30 Series

There are a total of 6 bytes required to obtain the status information from the LVU30 Series that will include target range, temperature, target strength, error condition and other information. The data format of the Status Request from host to sensor is as follows:

<u>Byte</u>	<u>Description</u>	<u>Value</u>
1	Sensor Request	170
2	Sensor ID Tag No.	1 to 32
3	Request Code	3 (status)
4	Placeholder byte	0
5	Placeholder byte	0
6	Checksum	sum of bytes 1 to 5, modulo 256

### 4.2 Response from LVU30 Series when STATUS information is requested

Upon receiving the Status request, the LVU30 Series will respond back with 6 bytes of Status data with the format defined as:

<u>Byte</u>	<u>Description</u>	<u>Value</u>
1	Sensor ID Tag No.	1 to 32
2	Response Code	8 bits parsed, see below
3	Range data byte (LSB)	see Notes 1 and 2
4	Range data byte (MSB)	see Notes 1 and 2
5	Temperature data	5 to 254, see Note 3 below
6	Checksum byte	Sum of bytes 1 to 5, modulo 256

Response Code data byte 2 parsed:

bit	<u>Z</u>	<u>6</u>	<u>5</u>	<u>4</u>	<u>Description</u>	bit	<u>Description</u>
	<b>0000</b>				0% target strength	<u>3</u>	Target Detected: <b>0</b> =NO <b>1</b> =YES
	<b>0001</b>				25% target strength	<u>2</u>	Vout operating mode: <b>0</b> =Linear <b>1</b> =Switch
	<b>0010</b>				50% target strength	<u>1</u>	If Switch Mode operation Vout: <b>0</b> =0Vout <b>1</b> =10Vout else Linear Mode = <b>0</b>
	<b>0011</b>				75% target strength	<u>0</u>	Set if sensor error, see Data Memory address 104, on page 8 for the error description
	<b>0100</b>				100% target strength		

#### Notes:

1. Range to target (average): Byte 3 (LSB) combined with byte 4 (MSB) to form 2 bytes, then divided by 128 (inches).
2. No target detected will be indicated as 0000 range and 0% target strength.
3. Temperature data is defined as deg C = (byte 5 \* 0.48876) – 50.
4. See page 8 for the response if there is a sensor error.

### 4.3 Request to WRITE to the LVU30 Series Data Memory

There are a total of 6 bytes required to write to the LVU30 Series Data Memory. These locations affect operation of the sensor including sample rate, averaging, loss of echo timeout, Voltage Output operating mode, Sensor ID tag, etc. The description to each Data Memory location is on pages 9-13. The data format is as follows:

<u>Byte</u>	<u>Description</u>	<u>Value</u>
1	Sensor Request	170
2	Sensor ID Tag No.	1 to 32
3	Request Code	103 (write to Data Memory)
4	Address of Data Memory	21 to 104
5	Data to be stored in memory	0 – 255 (limits indicated in Data Memory section of this guide)
6	Checksum	sum of bytes 1 to 5, modulo 256

There is no response from the LVU30 Series after a write request. Good design practice is to read back the Data Memory for verification (see next page). The LVU30 Series will verify that the Data Memory is within specified values as described in the Data Memory description section. Any invalid data will be replaced with the factory default value and will indicate a Data Memory replacement error (see page 8).

When a write command is initiated, the sensor will stop its normal operation and remain idle waiting for additional writing to the Data Memory. The sensor will only return to normal operation (with the new parameters in Data Memory) when a re-boot command is initiated (see page 8) or if it is re-powered.

**SPECIAL CASE:** The ID Tag memory address 40 must be unlocked by the command shown here prior to requesting the change. Note that any other command request other than the ID Tag change request will re-lock the ID Tag memory location.

<u>Byte</u>	<u>Description</u>	<u>Value</u>
1	Sensor Request	170
2	Sensor ID Tag No.	1 to 32
3	Request Code	105 (unlock ID Tag location 40)
4	Unlock value	12
5	Unlock value	234
6	Checksum	sum of bytes 1 to 5, modulo 256

This command must immediately follow with the standard write to Data Memory:

<u>Byte</u>	<u>Description</u>	<u>Value</u>
1	Sensor Request	170
2	Sensor ID Tag No.	1 to 32 (Sensor ID Tag you are requesting to change)
3	Request Code	103 (write to Data Memory)
4	Address of data memory	40
5	New ID Tag	1 to 32
6	Checksum	sum of bytes 1 to 5, modulo 256

The new ID Tag will take affect after a re-boot command (or power cycle).

#### 4.4 Request to READ from the LVU30 Series Data Memory

There are a total of 6 bytes required to access and read the Data Memory from the LVU30 Series. The data format is as follows:

<u>Byte</u>	<u>Description</u>	<u>Value</u>
1	Sensor Request	170
2	Sensor ID Tag No.	1 to 32
3	Request Code	104 (read)
4	Address of data memory	21 to 104
5	Placeholder byte	0
6	Checksum	sum of bytes 1 to 5, modulo 256

#### 4.5 Response from the LVU30 Series to a READ request of Data Memory

Upon the LVU30 Series receiving the read request for the specific Data Memory location, the LVU30 Series will respond back with 6 bytes of data with the format defined below:

<u>Byte</u>	<u>Description</u>	<u>Value</u>
1	Sensor ID Tag No.	1 to 32
2	Response Code	128 (read)
3	Address	address of Data Memory
4	Data Memory	data from address in byte 3
5	Data Memory	data from next higher address
6	Checksum	sum of bytes 1 to 5, modulo 256

See pages 9-13 for details on all the Data Memory locations.

#### 4.6 Request to SOFTWARE TRIGGER the LVU30 Series

If the LVU30 Series trigger mode is programmed for Software Trigger (memory address 94 = 1), the LVU30 Series will then remain idle until a Software Trigger request occurs. This trigger request will cause the sensor to transmit an ultrasonic pulse and acquire the range to target. Page 9 describes the trigger mode options. See Note 1 below on how long to wait before you request the status information from the sensor. You may also trigger all the sensors wired to the communication bus simultaneously by setting the sensor ID to 0 (zero). This is recommended when sensors are placed in close proximity to each other thus avoiding acoustic cross-talk and erroneous operation. The data format to trigger the LVU30 Series is as follows:

<u>Byte</u>	<u>Description</u>	<u>Value</u>
1	Sensor Request	170
2	Sensor ID Tag No.	1 to 32 (including 0, see Note 2)
3	Request Code	1 (trigger sensor to transmit)
4	Placeholder byte	0
5	Placeholder byte	0
6	Checksum	sum of bytes 1 to 5, modulo 256

Note 1: After you request a software trigger, you must wait a finite amount of time before you request for status information from the sensor so that it has time to capture the furthest target (model dependant). For the 210 kHz model, wait at least 10mS. For the 150 kHz models, wait at least 15mS. For the 95 kHz model, wait at least 40mS.

Note 2: If the Sensor ID Tag (byte 2) is zero, then all sensors on the communications bus will transmit at approximately the same time.

#### 4.7 Request for LVU30 Series MODEL TYPE and FIRMWARE REVISION LEVEL

There are a total of 6 bytes required to access the sensor's model type and firmware revision level. Shown below is the data format required to receive this information:

<u>Byte</u>	<u>Description</u>	<u>Value</u>
1	Sensor Request	170
2	Sensor ID Tag No.	1 to 32
3	Request Code	123 (model type /firmware revision request code)
4	Placeholder byte	0
5	Placeholder byte	0
6	Checksum	sum of bytes 1 to 5, modulo 256

#### 4.8 Response from the LVU30 Series when requesting MODEL TYPE and FIRMWARE REVISION LEVEL

Upon the LVU30 Series receiving the request for Model Type and Firmware Revision Level request, the LVU30 Series will respond back with 6 bytes of data with the format defined below:

<u>Byte</u>	<u>Description</u>	<u>Value</u>
1	Sensor ID Tag No.	1 to 32
2	Response Code	131 (model type /firmware revision response code)
3	Sensor Model Code	100 = LVU31, 101 = LVU33, 102 = LVU32 (guide will be updated to any future sensors)
4	Firmware Revision	data
5	Placeholder byte	0
6	Checksum	sum of bytes 1 to 5, modulo 256

#### 4.9 Response from the LVU30 Series on a SENSOR ERROR

An error is indicated in the Sensor Status response if byte 2 bit 0 = 1. The Data Memory address 104 will have at least a bit set indicating the source of the error (see Error Flags in the Data Memory Section, page 10). The LVU30 Series will respond back to the normal Status request with 6 bytes as defined below:

<u>Byte</u>	<u>Description</u>	<u>Value</u>
1	Sensor ID Tag No.	1 to 32
2	Response Code	bit 0 is set on error, other bits undetermined
3	Range data byte (LSB)	see note below
4	Range data byte (MSB)	see note below
5	Temperature data	5 to 255 (probe fault if less than 5)
6	Checksum	sum of bytes 1 to 5, modulo 256

Note: Range data bytes will be zero if Data Memory was replaced. Other errors may or may not have valid range. For example, a temperature probe fault error will still try to attempt to obtain a range and report it. An Internal Signal Detect error will report the range as zero and attempts to self correct. A Brown Out error may operate properly, but users should verify their power supply for minimum requirements.

Data Memory address 104 error flags (see page 10):

- If bit 0 set: A Data Memory location was replaced with a factory default value. Sensor sampling operation stops until user clears bit and re-boots the sensor.
- If bit 1 set: Internal Signal Detect error. Sensor will attempt to self correct.
- If bit 2 set: Temperature Probe error. Sensor will attempt to self correct.
- If bit 3 set: Brown out error. Sensor will attempt to self correct. Verify supply voltage.



#### 4.10 Resetting an LVU30 Series ERROR

The only two errors that can be reset are the Data Memory replacement and Brown Out errors. This can be done by writing a zero to the memory address **104**. After clearing the error, the sensor must be re-booted (see below). The sensor will attempt to self clear both the Internal Signal detect and Temperature Probe faults. The user cannot clear these errors.

#### 4.11 Request to REBOOT the LVU30 Series

There are a total of 6 bytes required to reboot the LVU30 Series. This command must be sent after you have completed writing to any or all LVU30 Series Data Memory locations to activate the changes (however re-powering the sensor will also activate the changes). The data structure is as follows:

<u>Byte</u>	<u>Description</u>	<u>Value</u>
1	Sensor Request	170
2	Sensor ID Tag No.	1 to 32
3	Request Code	119 (reboot)
4	Placeholder byte	0
5	Placeholder byte	0
6	Checksum	sum of bytes 1 to 5, modulo 256

The latter pages contain flowcharts to be used as guides in developing your code.

## 5 LVU30 Series Data Memory

---

The LVU30 Series Data Memory locations described below may be changed to tailor the sensor's operation to your particular application. The LVU30 Series will verify that you stay within product limits for proper operation. If you write invalid data to any location, the LVU30 Series sensor will replace the invalid data with the product default values after a re-boot command or next power up. Common practice is to verify the location you written to with the Read command (see page 6).

### 5.1 LVU30 Series Data Memory (General)

**5.1.1 ID Tag** is in Data Memory address **40**. Values in this location must be between **1** and **32**. This location requires a special unlock command to enable writing to this location. See page 5 for details. The default value is **1**.

**5.1.2 User Description Field** is in Data Memory address **41** thru **72**. These values must be ASCII codes from **32** through **126**. The default values are **32** (ASCII spaces).

**5.1.3 Voltage Output Operating Mode** is in Data Memory address **85**. This location defines the operating mode of the Sensor's Voltage Output. A **"0"** in this location operates the Voltage Output in a linear mode. The parameters that control the slope and min/max voltage values of the voltage output are located in data memory locations *Zero Setpoint Distance*, *Zero Setpoint Voltage Value*, *Span Setpoint Distance*, and *Span Setpoint Voltage Value* (see page 11). A **"1"** in this location operates the Voltage Output as switch. The parameters that control the switch points are located in data memory *Close Setpoint Distance*, *Far Setpoint Distance*, and *Switch Mode Output Operation* and *Setpoint Output Hysteresis* (see page 12).

**5.1.4 Average** is in Data Memory address **91**. This location is defined as follows: **0**=ave. of 1, **1**=ave. of 2, **2**=ave. of 4, **3**=ave. of 8, **4**=ave. of 16, **5**=ave. of 32, **6**=ave. of 64, **7**=ave. of 128, **8**=ave. of 256, **9**=ave. of 512, and **10**=ave. of 1024. The maximum average for the "Rolling" average type is 32 (or index value of 5). The default value is **0**.

**5.1.5 Average Type** is in Data Memory address **92**. This location is defined as follows: **"0"** = Rolling and **"1"** = Boxcar. By definition, a Rolling average uses the latest samples where each new sample replaces the oldest sample. A Boxcar average takes the selected number of samples before outputting the average reading, then starts a new average. The default value is **0** (Rolling).

**5.1.6. No Echo Time Out** is in Data Memory address **93**. This location is programmable from **1** to **254** representing the amount of consecutive missed echoes before the sensor reaches a loss of echo condition. This parameter is independent of the Average parameter. The default value is **1**.

**5.1.7 Trigger Mode** is in Data Memory address **94**. This location is defined as follows: **"0"** establishes normal operation or internal self triggering at a rate programmed by the Sample Rate (data memory location **100-103**). A **"1"** in this location places the sensor in a software trigger mode where a computer or other host is required to initiate the sensor to transmit (see Software Trigger command on page 7). The default value is **0** (internal).

**5.1.8 Sample Rate** is in Data Memory address 100 thru 103. This 4 byte location represents the sampling time for which the sensor transmits its ultrasonic pulse. Address 100 is the LSB thru 103 being the MSB. Resolution for all sensor model LVU31 Series is 200nS/bit, model LVU32 Series is 400nS/bit, and model LVU33 Series is 800nS/bit. The default value for all models is 10Hz.

**5.1.9 Temperature Compensation** is in Data Memory address **95**. This location is defined as follows: “0” = internal probe or “1” = manual temperature (see location 96). The default value is **0** (internal probe). The formula for the speed of sound compensation is:

$$c = 789.9147 * \text{SQRT}(\text{temperature in } ^\circ\text{C} + 273) \text{ inches/sec}$$

For round trip to get range, divide the above formula by 2.

**5.1.10 Manual Temperature Override** is in Data Memory address **96**. When address **95** is set to 1, Manual Temperature operation is in effect and the value in this location (**96**) is used in calculating the target distance. The temperature is defined as:

$$\text{Temp } ^\circ\text{C} = (\text{data memory } 96 * 0.48876) - 50$$

**5.1.11 Self Heating Correction** is in Data Memory address **24**. This location is defined as follows: “0” corrects for a self-heating error immediately at power up and is based on the input power supply voltage. The sensor’s self heating time is approximately 30 minutes where the sensor’s temperature probe will measure slightly low and will correct in time (30 min). This will give a slight error in reporting the range during this initial power up period (worst case error at power up). In most processes, the sensor is powered continuously, so it only affects the initial power up cycle. Subsequent power cycles (low off duty cycle) will report the temperature accurately.

When applications requires a sensor to be occasionally powered (very low ON duty cycles), setting this location to “1” disables self heating correction and will properly measure the ambient temperature. Note that if self heating is disabled and the sensor is powered continuously, then an error in reading the temperature will occur. The default value is **0** (self heating correction enabled).

**5.1.12 Error Flags** is in Data Memory address **104**. These are set when the sensor is in a fault condition. If **bit 0** is set, then at least one Data Memory location was programmed beyond the sensor limits and a factory default value replaced the data in error. The user should validate all Data Memory locations since more than one location could have been replaced. This particular error requires user intervention to clear by writing a “0” to this location.

Other errors indicators are **bit1** for an internal Signal Detect Error. **Bit 2** for an internal Temperature Probe Fault. And **bit 3** for a Brown Out error due to a low power supply. Errors indicated by bits 1 and 2 are self clearing and the sensor will try to recover on its own. The Brown Out error flag can be cleared by writing a zero to its location. It is possible for the LVU30 Series to continue to operate, even with this Brown Out flag set. However, users should check the power supply if this continues to be set.

## **5.2 LVU30 Series Data Memory (Linear Mode Parameters)**

**5.2.1 Zero Setpoint Distance** is in Data Memory address **73-74**. This 2 byte memory location represents the distance for the *Zero Setpoint Voltage Value* for the voltage output operating in the Linear Mode. The Voltage Output will operate linearly when a target is detected between this Zero Setpoint Distance and the Span Setpoint Distance. These 2 bytes are defined as **74** being the MSB and **73** being the LSB having a value of 128 times the range in inches<sup>1</sup>. The default value is the Sensor’s minimum specified distance and the limits are the sensors minimum and maximum specified ranges and must not equal the *Span Setpoint Distance*.

**5.2.2 Zero Setpoint Voltage Value** is in Data Memory address **77-78**. This 2 byte memory location is the voltage value for the *Zero Setpoint Distance* and is used when operating in the Linear Mode. The resolution for this 2 byte value is 1mV/bit with address **78** being MSB and **77** being LSB. The default value is **0** (0V).

**5.2.3 Span Setpoint Distance** is in Data Memory address **75-76**. This 2 byte memory location represents the distance for the *Span Setpoint Voltage Value* for the voltage output operating in the Linear Mode. The Voltage Output will operate linearly when a target is detected between the Zero Setpoint Distance and this Span Setpoint Distance. These 2 bytes are defined as **76** being the MSB and **75** being the LSB having a value of 128 times the range in inches<sup>1</sup>. The default value is the Sensor's maximum specified distance and the limits are the sensors minimum and maximum specified ranges and must not equal the *Zero Setpoint Distance*.

**5.2.4 Span Setpoint Voltage Value** is in Data Memory address **79-80**. This 2 byte memory location is the voltage value for the *Span Setpoint Distance* and is used when operating in the Linear Mode. The resolution for this 2 byte value is 1mV/bit with address **80** being MSB and **79** being LSB. The default value is **10,000** (10.00V).

**5.2.5 Loss of Echo Voltage Value** is in Data Memory address **86-87**. This value represents the voltage output when the sensor is in the *No Echo Condition* (see No Echo Timeout address 93 on page 9). The resolution for this 2 byte value is 1mV/bit with address **87** being MSB and **86** being LSB. The default value is **10250** (10.25V).

**5.2.6 Voltage Output Calibration** is in Data Memory address **22-23**. This 2 byte location represents the 10.00V calibration value. The factory calibrates this parameter, but it may be adjusted to your instrument. The limits are from **900** to **1023**.

Note 1: Example for a range value of 37.75" saved in data memory would be  $37.75 \times 128 = 4832_{10}$  or  $12E0_{16}$ . Thus in data memory store MSB= $12_{16}$  and LSB= $E0_{16}$  (MSB= $18_{10}$  and LSB= $224_{10}$ )

### 5.3 LVU30 Series DATA MEMORY (Switch Mode Parameters)

**5.3.1 Close Setpoint Distance** is in Data Memory address **81-82**. This 2 byte memory location is the distance used to establish a zone for the Voltage Output when operating in the Switch Mode. The 2<sup>nd</sup> setpoint used to create these zones is the *Far Setpoint Distance*. See *Switch Mode Output Operation* below for details on how the voltage output will operate. These 2 bytes are defined as **82** being the MSB and **81** being the LSB having a value of 128 times the range in inches (see note 1 previous page). This value must be less than the *Far Setpoint Distance*. The default value is the Sensor's minimum specified distance.

**5.3.2 Far Setpoint Distance** is in Data Memory address **83-84**. This 2 byte memory location is the distance used to establish a zone for the Voltage Output when operating in the Switch Mode. The 1<sup>st</sup> setpoint used to create these zones is the *Close Setpoint Distance*. See *Switch Mode Output Operation* below for details on how the voltage output will operate. These 2 bytes are defined as **84** being the MSB and **83** being the LSB having a value of 128 times the range in inches (see note 1 previous page). This value must be greater than the *Close Setpoint Distance*. The default value is the Sensor's maximum specified distance.

**5.3.3 Switch Mode Output Operation** is in Data Memory address **88**. This data location is used to establish what state the voltage output will be in when a target is detected within a particular zone created by the Close and Far Setpoint Distances (subject to Hysteresis, see below) when operating in the Switch Mode. The default value is **0**. The data byte is parsed as follows:

**bit 0:** No Echo

**0** = No Echo Vout=0V , Echo present Vout=10V

**1** = No Echo Vout=10V, Echo present Vout=0V

**bit 1:** Target > Far Setpoint Distance

**0** = If Target > Far Setpoint Distance, then Vout = 0V

**1** = If Target > Far Setpoint Distance, then Vout = 10V

**bit 2\*:** Target between Close and Far Setpoint Distances (\* bit 3 = 0 for this function, else see bit 3)

**0** = Target Present between Close and Far Setpoint Distances, Vout=0V

**1** = Target Present between Close and Far Setpoint Distances, Vout=10V

**bit 3:** No Change for Target between Close and Far Setpoint Distances

**0** = See bit 2 for operation of targets between Close and Far Setpoint Distances

**1** = No change in voltage output when targets enter between Close & Far Setpoint Distances  
(setting this to 1 will disable function of bit 2)

**bit 4:** Target < Close Setpoint Distance

**0** = If Target < Close Setpoint Distance, then Vout = 0V

**1** = If Target < Close Setpoint Distance, then Vout = 10V

**5.3.4 Setpoint Output Hysteresis** is in Data Memory address **90**. This location specifies the amount of hysteresis in %. The Close Setpoint Distance, Far Setpoint Distance, and Hysteresis must be chosen so that the Far Setpoint Distance with hysteresis applied is greater than the Close Setpoint Distance. This parameter is used when operating in the Switch Mode. The limits are **0** to **75%**. Hysteresis is defined as the distance between the operating point when a target approaches a setpoint and the release point when the target moves away from the setpoint towards its original position. The default value is **5** (percent).

**5.3.5 Maximum Sensing Range** is in Data Memory address **98-99**. This programmed value limits how far the sensor detects objects. These 2 bytes are defined as **99** being the MSB and **98** being the LSB having a value of 128 times the range in inches (see note 1 previous page). This parameter can be useful if you would like to eliminate a fixed background target and have the sensor indicate it as "No Echo". The default value is the Sensor model maximum specified sensing range.

## 5.4 LVU30 Series Data Memory (Sensitivity Adjustment Parameters)

The LVU30 Series Sensor has a sensitivity adjustment that can set both in amplitude and in time where it occurs. Omega has developed a set of adjustments as seen in the LVU30 Series Software drop down menu. This includes *Normal*, *Normal High-Temperature*, *Low*, *Very Low*, *High* and *Very High*. These thresholds have been developed for typical or not so typical applications. Most applications should use the *Normal* setting. However applications such as the sensor being in a very hot environment (over 130°F) may want to select *Normal High-Temperature*. *High* settings improve acquiring a weak target, but may have other issues like detecting unwanted targets, so use these *High* settings with care. In applications such as a sensor aiming down a narrow pipe, the *Low* setting may be selected to avoid side reflections. Described below are the Data Memory locations that affect the sensitivity adjustment of the sensor. However it is highly recommended that if you change from the *Normal* setting that you fully evaluate operation of the sensor in your application. The LVU30 Series Software has a menu item that displays the ultrasonic signals and will show the threshold levels as programmed.

**5.4.1 Threshold Voltage #1** is in Data Memory address **30**. This is the initial voltage level set. The value is indexed from **1** to **18** and is defined as:

**1**=1.25V, **2**=1.41V, **3**=1.46V, **4**=1.56V, **5**=1.67V, **6**=1.72V, **7**=1.88V, **8**=2.03V, **9**=2.08V, **10**=2.19V, **11**=2.29V, **12**=2.34V, **13**=2.50V, **14**=2.66V, **15**=2.71V, **16**=2.81V, **17**=2.92V, **18**=2.97V.

**5.4.2 Threshold Voltage #2** is in Data Memory address **31**. This is the next level change that can be set and will occur at the timing parameter *Switch time for Threshold #2*. The value is indexed from **1** to **18** and as described in *Threshold Voltage #1*. However, programming this location to a **0** will turn off this voltage level change.

**5.4.3 Threshold Voltage #3** is in Data Memory address **32**. This is the next level change that can be set and will occur at the timing parameter *Switch time for Threshold #2*. The value is indexed from **1** to **18** and as described in *Threshold Voltage #1*. However, programming this location to a **0** will turn off this voltage level change.

**5.4.4 Threshold Voltage #4** is in Data Memory address **33**. This is the next level change that can be set and will occur at the timing parameter *Switch time for Threshold #2*. The value is indexed from **1** to **18** and as described in *Threshold Voltage #1*. However, programming this location to a **0** will turn off this voltage level change.

**5.4.5 Switch Time for Threshold Voltage #2** is in Data Memory address **33-34**. This 2 byte value represents the time from transmission of the ultrasonic pulse to the voltage level changing to *Threshold Voltage #2*. The MSB is stored in **34** and the LSB is in **33**. See note below for the defined unit value.

**5.4.6 Switch Time for Threshold Voltage #3** is in Data Memory address **35-36**. This 2 byte value represents the time from transmission of the ultrasonic pulse to the voltage level changing to *Threshold Voltage #3*. The MSB is stored in **36** and the LSB is in **35**. See note below for the defined unit value.

**5.4.7 Switch Time for Threshold Voltage #4** is in Data Memory address **37-38**. This 2 byte value represents the time from transmission of the ultrasonic pulse to the voltage level changing to *Threshold Voltage #4*. The MSB is stored in **34** and the LSB is in **33**. See note below for the defined unit value.

Note: The Switch Time for Threshold Voltage is model dependant. The LVU31 Series is 200nS per bit, LVU32 Series is 400nS per bit, and the LVU33 Series is 800nS per bit.

## 6 Flow Charts

### LVU30 SERIES Flow Chart for Status Information on Multiple Sensors

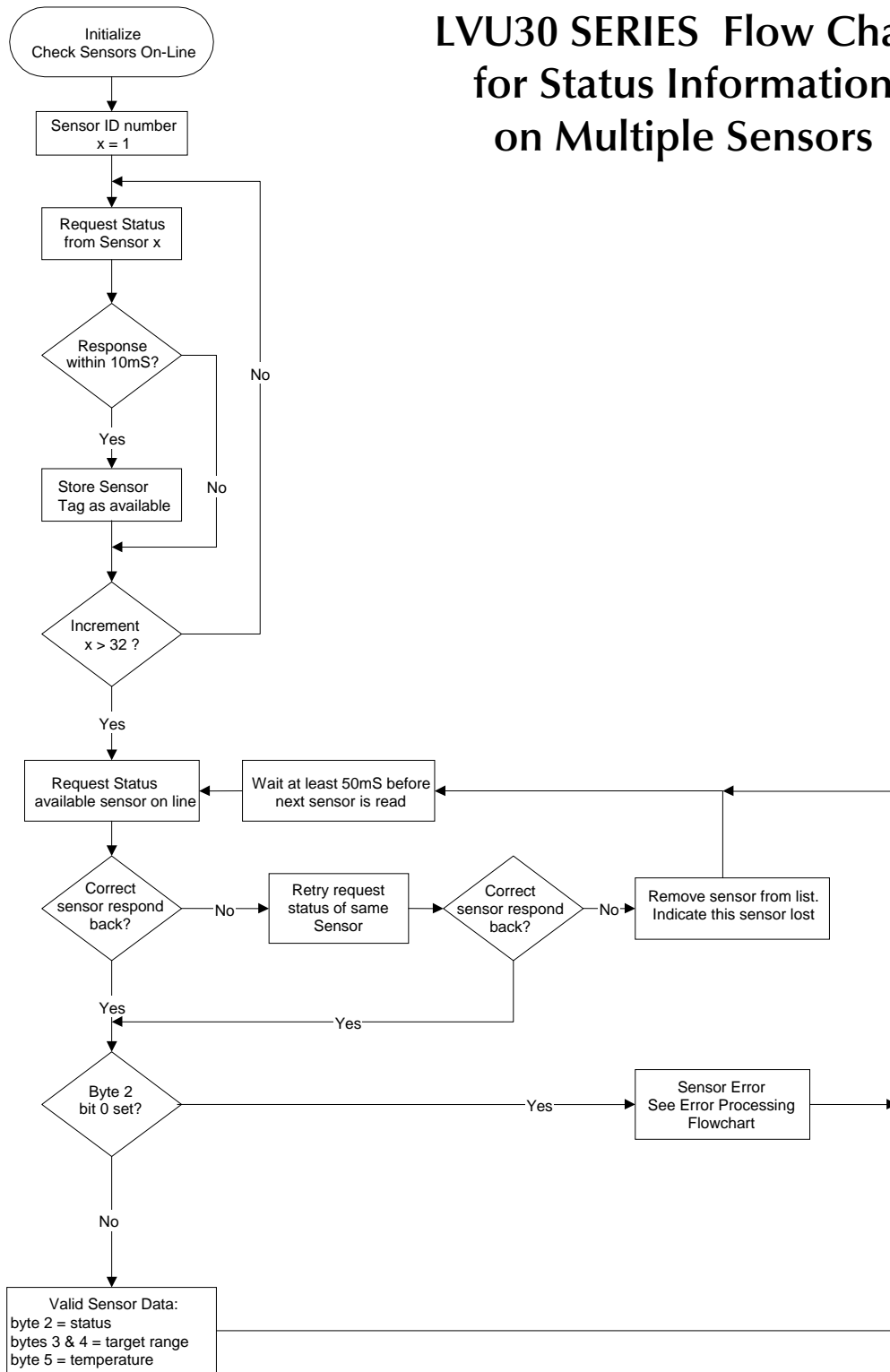

## LVU30 SERIES Flowchart for Writing to Data Memory

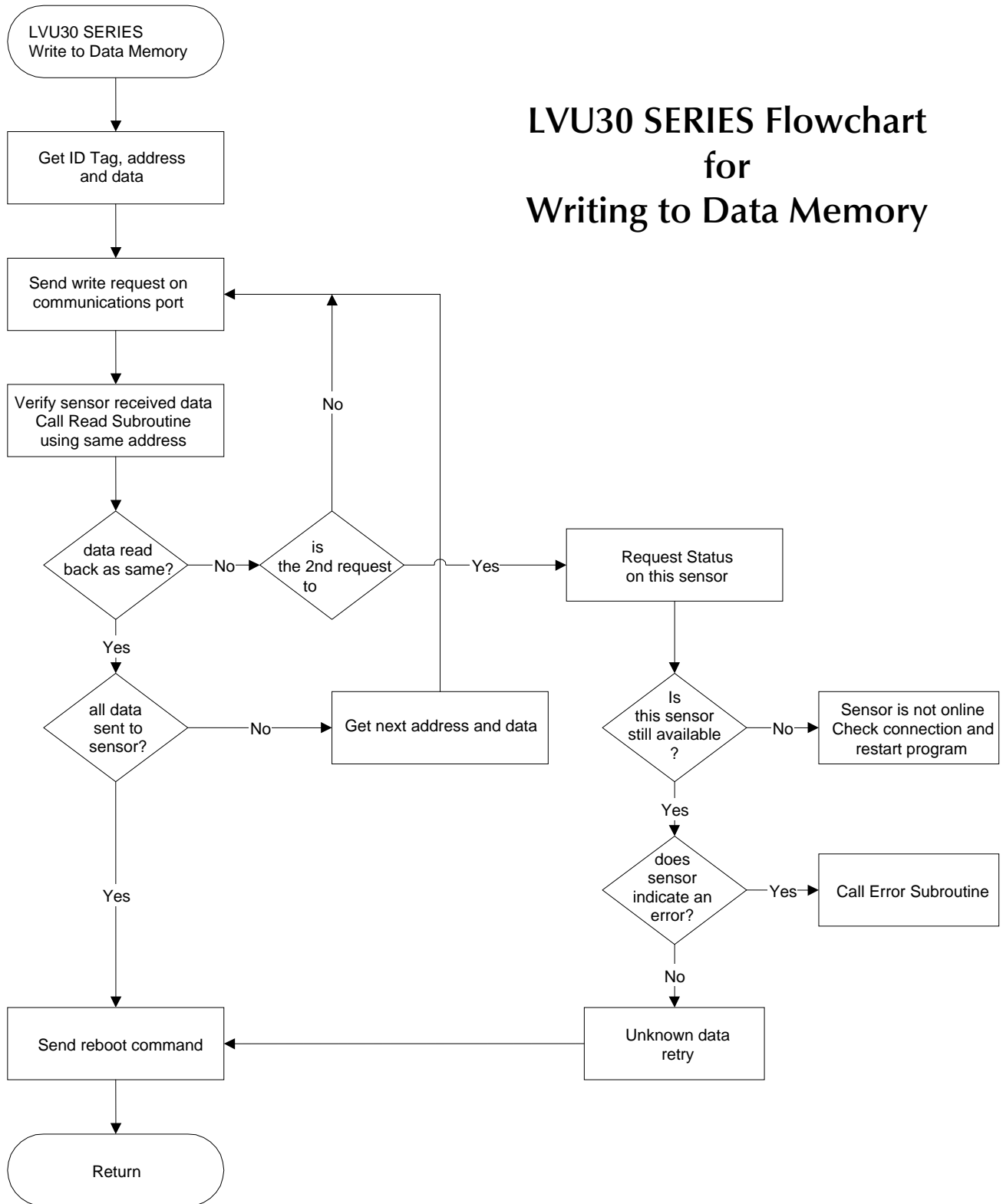



# LVU30 SERIES Flowchart for

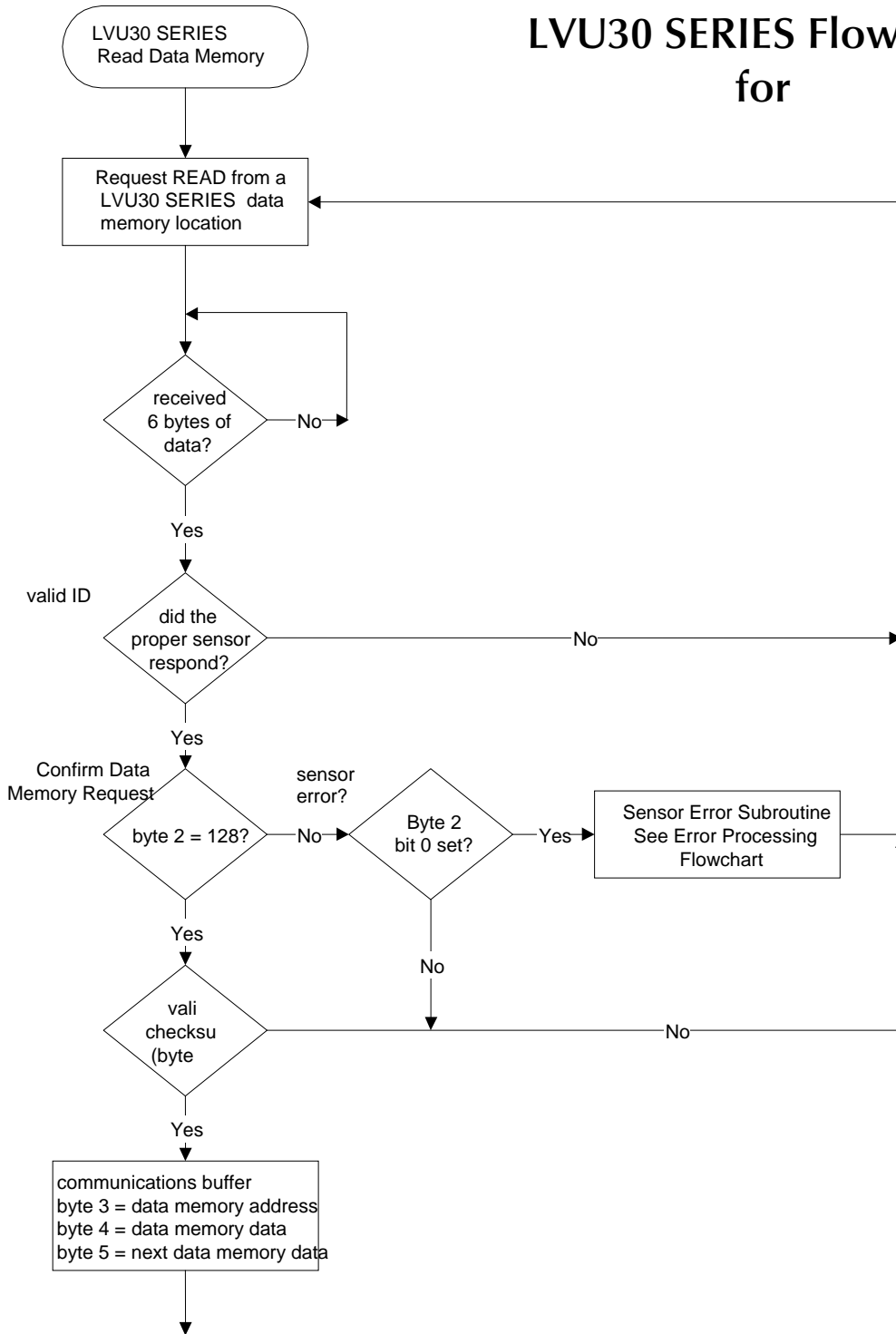

# LVU30 SERIES Flowchart for Error Processing

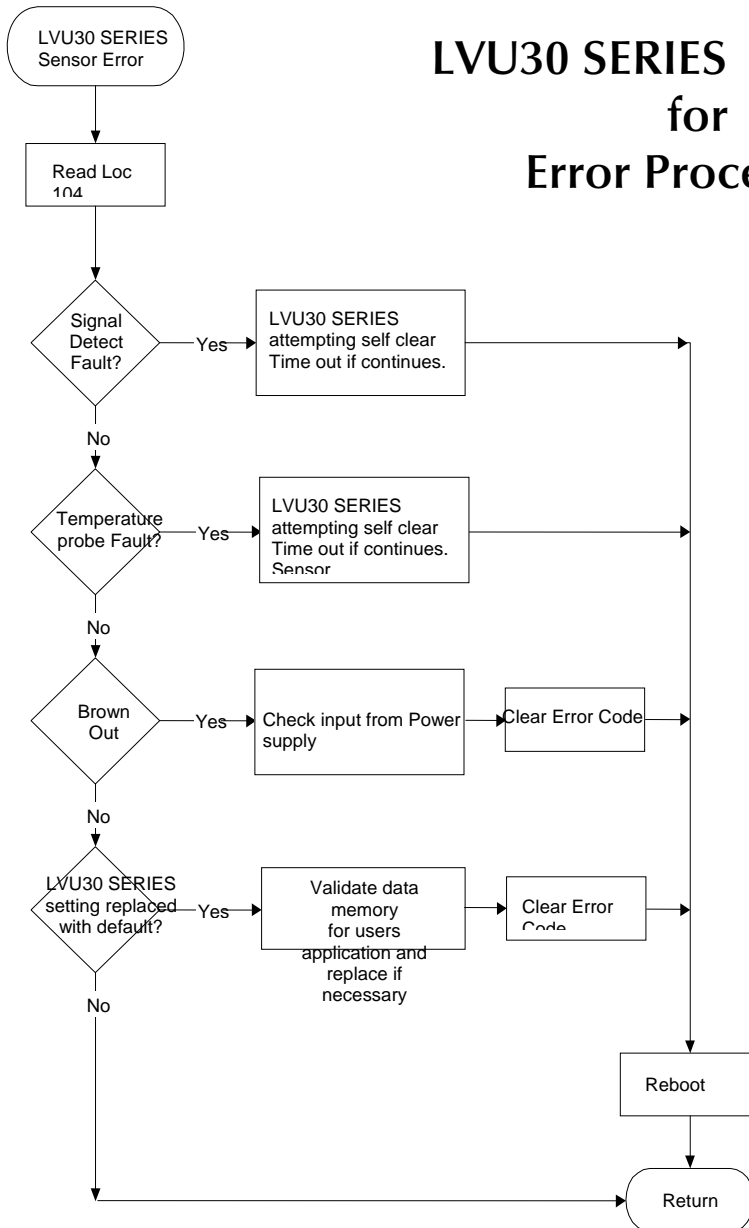

## WARRANTY/DISCLAIMER

OMEGA ENGINEERING, INC. warrants this unit to be free of defects in materials and workmanship for a period of **13 months** from date of purchase. OMEGA's WARRANTY adds an additional one (1) month grace period to the normal **one (1) year product warranty** to cover handling and shipping time. This ensures that OMEGA's customers receive maximum coverage on each product.

If the unit malfunctions, it must be returned to the factory for evaluation. OMEGA's Customer Service Department will issue an Authorized Return (AR) number immediately upon phone or written request. Upon examination by OMEGA, if the unit is found to be defective, it will be repaired or replaced at no charge. OMEGA's WARRANTY does not apply to defects resulting from any action of the purchaser, including but not limited to mishandling, improper interfacing, operation outside of design limits, improper repair, or unauthorized modification. This WARRANTY is VOID if the unit shows evidence of having been tampered with or shows evidence of having been damaged as a result of excessive corrosion; or current, heat, moisture or vibration; improper specification; misapplication; misuse or other operating conditions outside of OMEGA's control. Components in which wear is not warranted, include but are not limited to contact points, fuses, and triacs.

**OMEGA is pleased to offer suggestions on the use of its various products. However, OMEGA neither assumes responsibility for any omissions or errors nor assumes liability for any damages that result from the use of its products in accordance with information provided by OMEGA, either verbal or written. OMEGA warrants only that the parts manufactured by the company will be as specified and free of defects. OMEGA MAKES NO OTHER WARRANTIES OR REPRESENTATIONS OF ANY KIND WHATSOEVER, EXPRESSED OR IMPLIED, EXCEPT THAT OF TITLE, AND ALL IMPLIED WARRANTIES INCLUDING ANY WARRANTY OF MERCHANTABILITY AND FITNESS FOR A PARTICULAR PURPOSE ARE HEREBY DISCLAIMED. LIMITATION OF LIABILITY: The remedies of purchaser set forth herein are exclusive, and the total liability of OMEGA with respect to this order, whether based on contract, warranty, negligence, indemnification, strict liability or otherwise, shall not exceed the purchase price of the component upon which liability is based. In no event shall OMEGA be liable for consequential, incidental or special damages.**

CONDITIONS: Equipment sold by OMEGA is not intended to be used, nor shall it be used: (1) as a "Basic Component" under 10 CFR 21 (NRC), used in or with any nuclear installation or activity; or (2) in medical applications or used on humans. Should any Product(s) be used in or with any nuclear installation or activity, medical application, used on humans, or misused in any way, OMEGA assumes no responsibility as set forth in our basic WARRANTY/DISCLAIMER language, and, additionally, purchaser will indemnify OMEGA and hold OMEGA harmless from any liability or damage whatsoever arising out of the use of the Product(s) in such a manner.

## RETURN REQUESTS/INQUIRIES

Direct all warranty and repair requests/inquiries to the OMEGA Customer Service Department. BEFORE RETURNING ANY PRODUCT(S) TO OMEGA, PURCHASER MUST OBTAIN AN AUTHORIZED RETURN (AR) NUMBER FROM OMEGA'S CUSTOMER SERVICE DEPARTMENT (IN ORDER TO AVOID PROCESSING DELAYS). The assigned AR number should then be marked on the outside of the return package and on any correspondence.

The purchaser is responsible for shipping charges, freight, insurance and proper packaging to prevent breakage in transit.

FOR **WARRANTY** RETURNS, please have the following information available BEFORE contacting OMEGA:

1. Purchase Order number under which the product was PURCHASED,
2. Model and serial number of the product under warranty, and
3. Repair instructions and/or specific problems relative to the product.

FOR **NON-WARRANTY** REPAIRS, consult OMEGA for current repair charges. Have the following information available BEFORE contacting OMEGA:

1. Purchase Order number to cover the COST of the repair,
2. Model and serial number of the product, and
3. Repair instructions and/or specific problems relative to the product.

OMEGA's policy is to make running changes, not model changes, whenever an improvement is possible. This affords our customers the latest in technology and engineering.

OMEGA is a registered trademark of OMEGA ENGINEERING, INC.

© Copyright 2006 OMEGA ENGINEERING, INC. All rights reserved. This document may not be copied, photocopied, reproduced, translated, or reduced to any electronic medium or machine-readable form, in whole or in part, without the prior written consent of OMEGA ENGINEERING, INC.

# Where Do I Find Everything I Need for Process Measurement and Control? **OMEGA...Of Course!** *Shop online at [omega.com](http://omega.com)*

## **TEMPERATURE**

- Thermocouple, RTD & Thermistor Probes, Connectors, Panels & Assemblies
- Wire: Thermocouple, RTD & Thermistor
- Calibrators & Ice Point References
- Recorders, Controllers & Process Monitors
- Infrared Pyrometers

## **PRESSURE, STRAIN AND FORCE**

- Transducers & Strain Gages
- Load Cells & Pressure Gages
- Displacement Transducers
- Instrumentation & Accessories

## **FLOW/LEVEL**

- Rotameters, Gas Mass Flowmeters & Flow Computers
- Air Velocity Indicators
- Turbine/Paddlewheel Systems
- Totalizers & Batch Controllers

## **pH/CONDUCTIVITY**

- pH Electrodes, Testers & Accessories
- Benchtop/Laboratory Meters
- Controllers, Calibrators, Simulators & Pumps
- Industrial pH & Conductivity Equipment

## **DATA ACQUISITION**

- Data Acquisition & Engineering Software
- Communications-Based Acquisition Systems
- Plug-in Cards for Apple, IBM & Compatibles
- Datalogging Systems
- Recorders, Printers & Plotters

## **HEATERS**

- Heating Cable
- Cartridge & Strip Heaters
- Immersion & Band Heaters
- Flexible Heaters
- Laboratory Heaters

## **ENVIRONMENTAL MONITORING AND CONTROL**

- Metering & Control Instrumentation
- Refractometers
- Pumps & Tubing
- Air, Soil & Water Monitors
- Industrial Water & Wastewater Treatment
- pH, Conductivity & Dissolved Oxygen Instruments