

2 YEAR
WARRANTY



Ω OMEGA™ **User's Guide**



***Shop online at
omega.com***

***e-mail: info@omega.com
For latest product manuals:
www.omegamanual.info***

BB705 **Very High Temperature Laboratory Blackbody Calibration Source**



omega.com info@omega.com

Servicing North America:

**U.S.A.
Headquarters:**

Omega Engineering, Inc.

Toll-Free: 1-800-826-6342 (USA & Canada only)

Customer Service: 1-800-622-2378 (USA & Canada only)

Engineering Service: 1-800-872-9436 (USA & Canada only)

Tel: (203) 359-1660

Fax: (203) 359-7700

e-mail: info@omega.com

For Other Locations Visit omega.com/worldwide

Table of Contents

Section	Page
Section 1 Introduction	1-1
1.1 Precautions	1-1
1.2 Safety Warnings and IEC Symbols	1-1
1.3 General Description	1-2
Section 2 Installation	2-1
2.1 Unpacking and Inspection	2-1
2.2 Mounting	2-1
2.3 Ambient Temperature	2-1
2.4 Power Connection	2-2
Section 3 Operation	3-1
3.1 Front Panel Controls and Indicators	3-1
3.2 Heater Cavity and Aperture Plate	3-2
3.3 Rear Panel	3-4
3.4 Controller Settings	3-5
3.4.1 Changing the Temperature Setpoint	3-5
3.4.2 Changing the Controller Parameter Settings	3-6
3.5 Temperature Reference Meter Settings	3-7
3.6 Target Cavity Temperature Transition Table	3-8
Section 4 RS232 Communications	4-1
Section 5 Maintenance	5-1
5.1 Calibration	5-1
5.2 Cleaning	5-1
5.2.1 Main Body	5-1
5.2.2 Heater Cavity	5-1
5.2.3 Fan	5-1
5.3 Fuse Replacement	5-1
Section 6 Specifications	6-1
Section 7 Troubleshooting Guide	7-1
Section 8 Glossary of Terms Used in This Manual	8-1

Table of Figures

Figure	Description	Page
1	IEC Symbols	1-2
2	Front Panel	3-1
3	Heater Cavity Dimensions	3-3
4	Aperture Plate	3-3
5	Rear Panel	3-4
6	Controller Default Parameters	3-6
7	Controller Programming Procedures	3-7
8	Approximate Target Plate Temperature Transition Times	3-8
9	Connecting a PC to the BB705's Controller/Reference Meter Serial Port	4-1

Section 1 - Introduction

Your BB700 Series Blackbody Calibration Source has been designed for ease of use and reliability whenever you have the need to test or calibrate non-contact infrared temperature instruments. It is important that you read this manual completely and follow all safety precautions before operating this instrument.

1.1 Precautions

- Follow all safety precautions and operating instructions outlined in this manual.
- Never leave your calibrator unattended when in use.
- Keep out of reach of children.
- Never touch the aperture plate or header cavity when hot.
- Never place any flammable or explosive material near the cavity opening.
- Do not operate in flammable or explosive environments.
- Never operate with a power cord other than the one provided with your unit.
- Remove or disconnect main power cord before attempting any maintenance or fuse replacement.
- Do not connect this unit to a non-grounded, non-polarized outlet or power source.
- This unit is intended for indoor use only. Avoid exposure to any moisture or rain.
- Do not connect the serial ports to equipment with exposed, hazardous, live voltages.
- The operator of this instrument is advised that if the equipment is used in a manner not specified in this manual, the protection provided by the equipment may be impaired.



NOTE:

There are no user serviceable parts inside your unit. Attempting to repair or service your unit may void your warranty.

1.2 Safety Warnings and IEC Symbols

This device is marked with international safety and hazard symbols in accordance with IEC 1010. It is important to read and follow all precautions and instructions in this manual before operating or commissioning this device as it contains important information relating to safety and EMC. Failure to follow all safety precautions may result in injury and or damage to your calibrator. Use of this device in a manner not specified by the manufacturer may impair protection provided within the unit.





IEC symbols	Description
	Caution, risk of electric shock
	Caution, refer to accompanying documents
	Caution, hot surface
	230 VAC @50/60Hz (European Models) 115 VAC @50/60Hz (Domestic Models)

Figure 1. IEC symbols

1.3 General Description

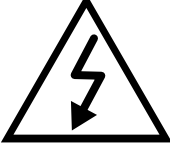
The Model BB705 is a very high temperature, laboratory grade, blackbody calibration source. The calibrator is used to test and calibrate infrared pyrometers. The calibration source, with built-in PID digital controller, maintains an accuracy of 0.25% of reading $\pm 1^{\circ}\text{C}$. The cavity has a 44.5 mm (1.75") diameter aperture with an emissivity of 0.99 and can be set to any temperature from 100 to 1046 $^{\circ}\text{C}$ (212 to 1915 $^{\circ}\text{F}$).

Section 2 - Installation

2.1 Unpacking and Inspection

Remove the packing list and verify that you have received all your equipment. If you have any questions about the shipment, please call our Customer Service Department at

1-800-622-2378 or 203-359-1660. We can also be reached on the Internet at **www.omega.com**
e-mail: cservice@omega.com

When you receive the shipment, inspect the container and equipment for any signs of damage. Note any evidence of rough handling in transit. Immediately report any damage to the shipping agent.

NOTE:

The carrier will not honor any damage claims unless all shipping material is saved for inspection. After examining and removing contents, save packing material and carton in the event reshipment is necessary.

The following items are supplied in the box:

Item:	OMEGA Part Number:
BB705 Blackbody Calibration Source	BB705 or BB705-230
User Manual	M-3638
Calibration Certificate	CAL-3 (3 DATA POINTS)
Power Cord	200-0028 (Domestic), 200-0107 (International)

2.2 Mounting

Mount the unit on a bench, table top or shelf in a horizontal position and operate at least ten inches from any air obstructions to the fan, front panel, rear panel, sides and top of the unit, in an ambient environment between the specified 0 to 35°C (32 to 95°F).

2.3 Ambient Temperature

The target cavity of the BB705 can achieve any temperature within the specified temperature range when being operated in normal specified ambient temperature environments. The maximum specified target plate temperature of 1046°C (1915°F) can be achieved over the entire specified ambient temperature range of 0 to 35°C (32 to 95°F).

2.4 Power Connection

Standard (115 VAC~, 50/60 Hz Models)

The BB705 comes with a standard North American 3-prong AC power cord. Do not use any other power cord other than the one provided. This cord provides the proper grounding and has been safety tested by the proper safety agencies.

International (230 VAC~, 50/60 Hz Models)

On 230 VAC~, 50/60Hz models an International style power cord with the proper color code and approvals is provided with stripped wire ends for connection to the proper connector used in your country or local area, this connector is not provided.

CAUTION:

- Electrical connections and wiring should be performed only by suitably trained personnel.
 - Be sure that the line voltage powering your unit does not go above or below 10% of the rated voltages specified above.
-

Section 3 - Operation

3.1 Front Panel Controls and Indicators

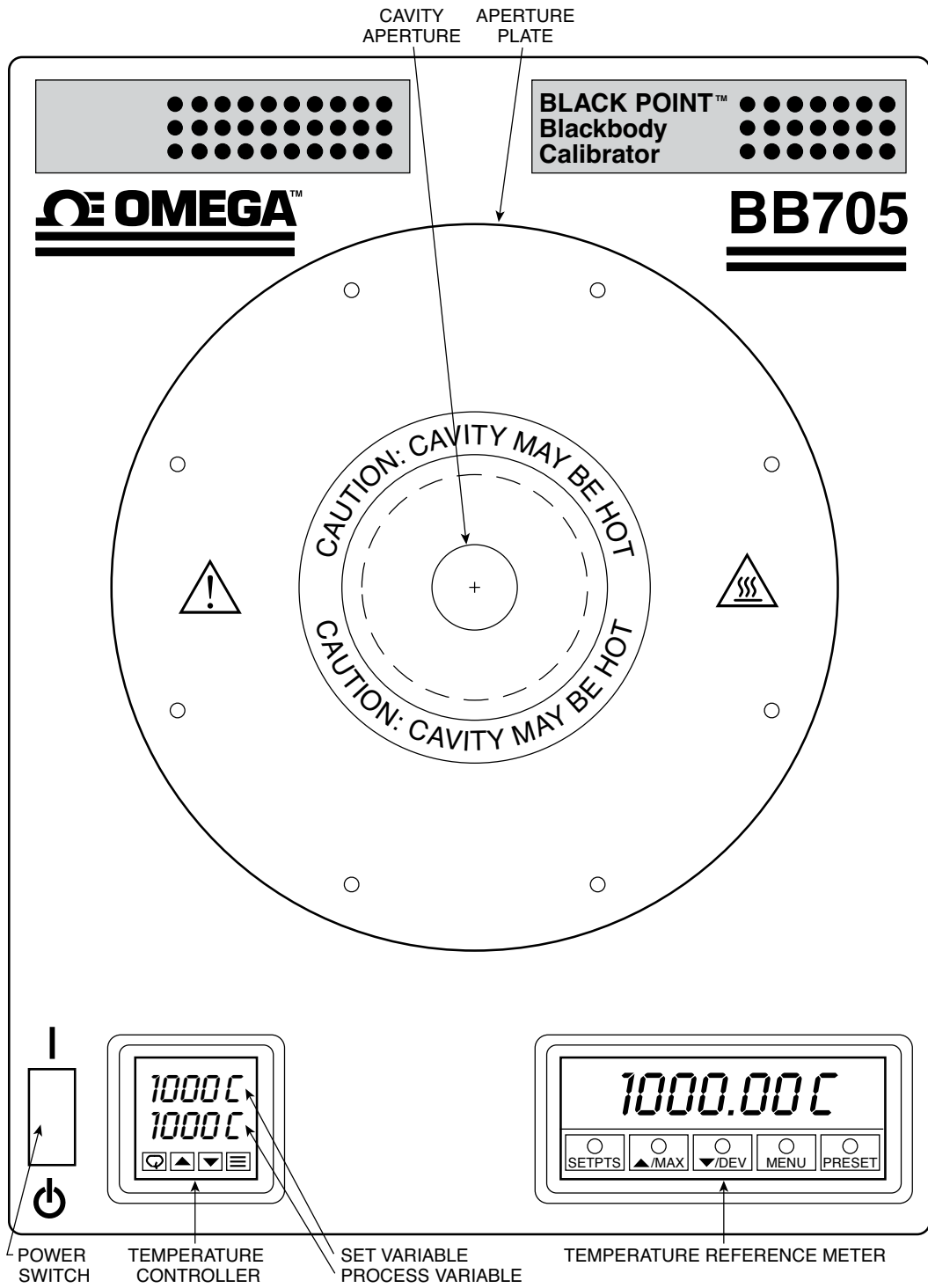



Figure 2. Front Panel

Power Switch

The power switch has two positions, "ON" and "STANDBY."



The fans are activated whenever the unit is plugged into a live power outlet. Regardless of whether the power switch is on, the fans will run for a period of 2 hours or until the power is turned on. The fans will remain on as long as the unit is turned on. Once the unit is switched from "ON" mode | to "STANDBY" mode  the fans will again run for 2 hours. **Never disconnect the power cord while the unit is still cooling down. A safety hazard may result and the unit may get damaged.**

Temperature Controller:

The controller is used for setting the desired temperature of the cavity. The controller display provides process temperature and setpoint temperature. A 4 button keypad is used to set the setpoint temperature and change engineering units.

Temperature Reference Meter:

The temperature reference meter displays the cavity temperature with high precision. See Section 3.5 for parameter programming information.

3.2 Heater Cavity and Aperture Plate

The heater cavity is a near ideal blackbody source. The emissivity of the cavity is 0.99. When calibrating an IR pyrometer, hold the pyrometer perpendicular to the aperture for optimal performance. The proper distance between the IR pyrometer and the target plate depends on the field of view of the pyrometer. If the pyrometer is too far away, it will scan unwanted surfaces outside of the perimeter of the target plate. Holding the pyrometer too close could introduce undesirable heat to the IR detector of the pyrometer. Always aim the gun toward the center of the cavity cone. Then search for the hottest spot. Use the pyrometer's peak detector feature.

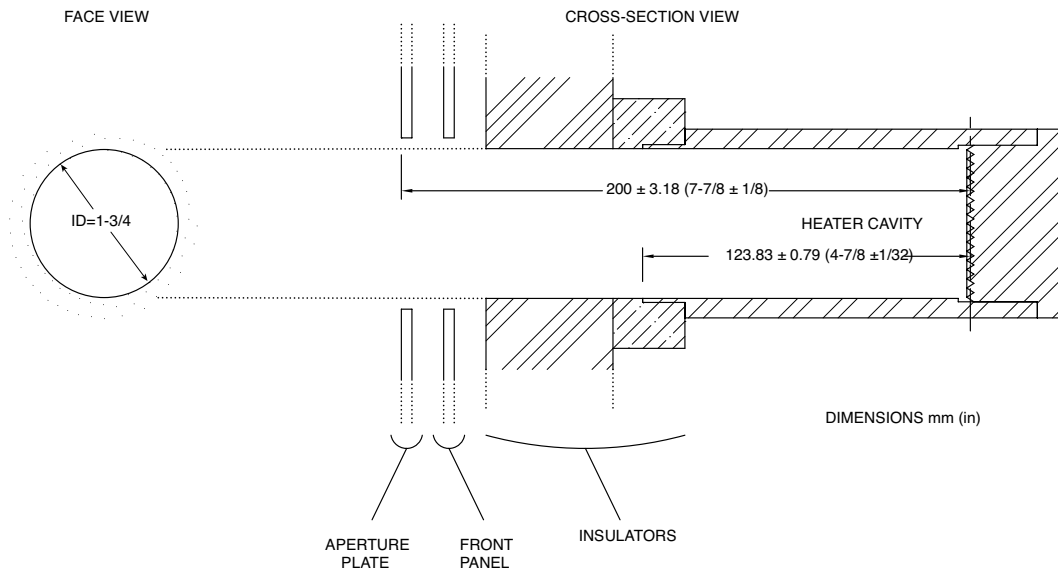
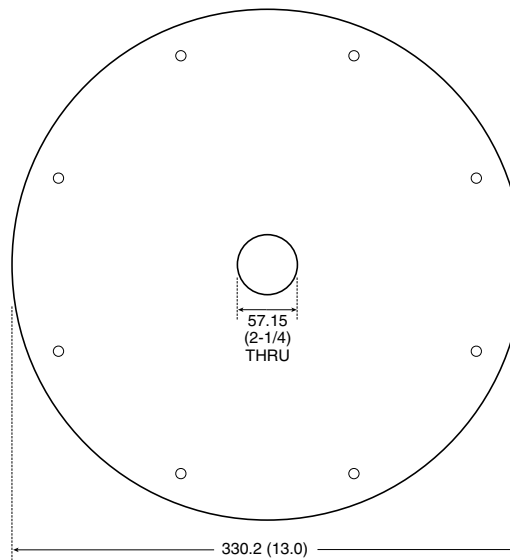

Figure 3. Heater Cavity Dimensions

WARNING:



- The BB705's heater cavity can be set to very high temperatures. Exercise extreme caution when operating the unit. Keep hands and fingers away from the heater cavity aperture and aperture plate area. Keep flammable products such as paper, plastics and clothing far from the BB705.
- The BB705 is a Class II instrument. It is intended to be operated in laboratory environment only. Never operate the unit outside or around children.
- Nothing should come in contact with the heater cavity aperture or aperture plate. Even when the unit is off.
- Never unplug the unit while it is on or during "Cool-Down."



The 8 equally spaced mounting holes are 0.457 mm (0.180") in diameter and are on an 293.6 mm (11.56") diameter bolt circle. The plate is anodized aluminum.

Figure 4. Aperture Plate

3.3 Rear Panel

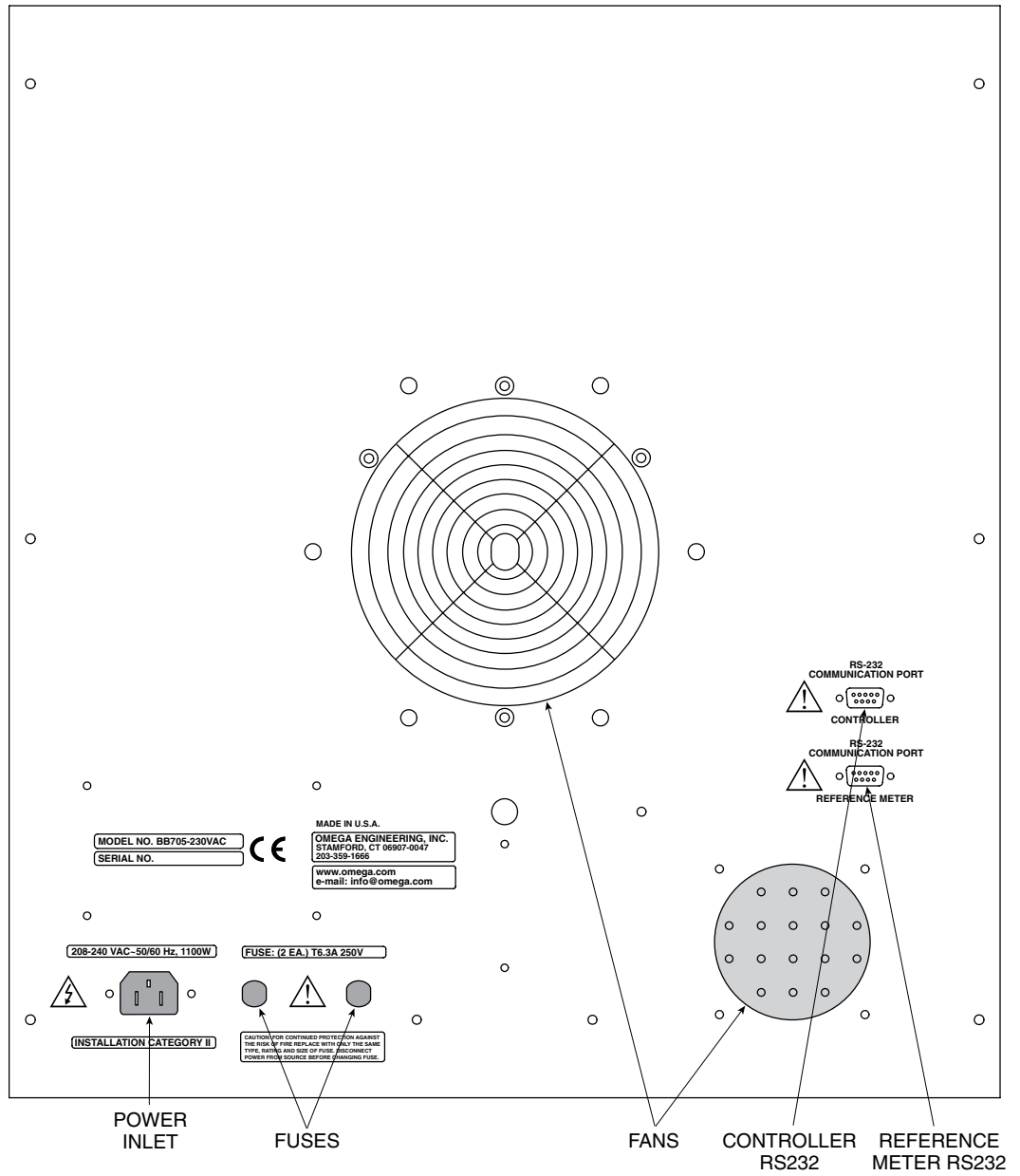

Figure 5. Rear Panel

AC Power Inlet:

The customer connects the power cord to the AC Power Input. As a safety precaution, the power cord cannot be connected if the fuse compartment is open. Refer to Section 5.3 for information on fuse replacement.

Fuses:

The fuses are replaceable by removing the fuse cap with a screwdriver. Domestic models (115V) have $\frac{1}{4} \times 1\frac{1}{4}$ " fuse, International models (230V) have two 5 x 20 mm fuses. **Be sure to disconnect the power cord before checking or replacing fuses.** See Section 5.3 for fuse specification information.

RS-232 Communication Ports:

The female DP-9 ports allow the customer to make a 3-wire RS-232 interface with the controller and the reference meter. A detailed description of this part is described in Section 4.

3.4 Controller Settings

3.4.1 Changing the Temperature Setpoint

Definitions:

Process Variable:

This field displays the current temperature of the target plate.

Setpoint Temperature:

This field displays the desired target plate temperature. Once the target plate reaches this desired temperature, both displays will read the same value.

Controller Keys:



Parameter/Access Key:

Press to scroll through menu parameters



Raise Key:

In the normal operating mode, press this key to increase the setpoint temperature. In the programming mode, use this key to increase the menu level or the value of a selected parameter.



Lower Key:

In the normal operating mode, press this key to decrease the setpoint temperature. In the programming mode, use this key to decrease the menu level or the value of a selected parameter.



Mode Key:

Press to save settings and exit a menu level.

The layout of the front panel is shown in Figure 2. The BB705 incorporates a PID digital temperature controller. In the default mode, the digital displays the process variable (PV) as well as the setpoint variable (SV). The process variable in the BB705 is the current measured temperature of the heater cavity. The

setpoint variable is the desired temperature the user has set. Setpoint temperature can be changed by depressing the “▲” and “▼” keys. Holding either of these keys for an extended period will cause the setpoint temperature to advance more quickly to a desired value. Three scanning speeds are provided: slow, medium and fast. The minimum and maximum setpoints are locked at 0 and 1046°C (32 and 1915°F), respectively. **While these max. and min. settings are changeable (see “Changing Controller Parameter Settings,” Section 3.4.2), it is strongly advised not to adjust these parameters.**

NOTE:

P.I.D. Control:

Proportional, integral, derivative control (P.I.D.) is a temperature control algorithm used in high-end temperature controllers. The controller causes the process to attain the desired temperature by turning the process on or off. The process may be a heater or refrigerator. As the process temperature approaches the setpoint temperature the hot or cold process will be pulsed to reduce the corrective measures and minimize overshooting. The controller provides a visual representation of the process status through LED indicators. An indicator may be lit continuously, blink or shut off entirely to indicate that the process is on, being pulsed, or off, respectively.

3.4.2 Changing the Controller Parameter Settings

The BB705's controller operates at its optimum performance when left with the factory parameter settings. The only internal parameter that the operator may need to change is the engineering units (°C or °F) or serial communications parameters. If the parameter settings are accidentally altered or become lost, the parameters should be re-programmed in according to the factory default settings. Below are two diagrams: a) menu hierarchy with factory default settings b) programming procedure.

Menu 00	Menu 01	Menu 02	Menu 03	Menu 04	Menu 05	
Key Lock	SETPOINT	Ac.Cd = 02	Ac.Cd = 03	Ac.Cd = 04	Ac.Cd = 05	
	Ac.Cd					
	Gn.o1	193 [†]	ALr1	1925	id.no 01	SnSr S
	Gr.o2		ALr2		bAUd 12.o.7	Sn.00
	rAtE	29 [†]	Cy.t1	01	CAL.L	dEC.P
	rSEt	146 [†]	Cy.t2		CAL.H	FILt
	H.Hys		SP.tt	OFF		OUt.1 Ht.P
	HyS.1		L.SP.L	212		OUt.2 Alr
	C.HyS		L.SCL			CoL.t nor
	HyS.2		U.SP.L	1915		A1.HL HI
	C.SPr		H.SCL			A1.Pd Pr
	SPr.2					A1.OP LAt
	dPnG	NI				A2.HL HI
						A2.Pd Pr
						A2.OP OFF
						Unit F

[†] Suggested starting values shown above. Actual values will be determined and automatically updated by Autotune function.

Figure 6. Controller Default Parameters







1. Press the  once.
2. Use the  and  keys to select menu level.
3. Once the the desired menu appears, scroll through the parameters of that menu using the  key.
4. Use the  and  keys to adjust a given parameter.
5. Press  to save settings and exit programming mode.
6. Re-enter the programming mode (from step #1) to access other menus.

Figure 7. Controller Programming Procedures

3.5 Temperature Reference Meter Settings

The high accuracy temperature reference meter has been calibrated at the factory and need not be adjusted by the user except for setting the engineering units ($^{\circ}\text{F}$ or $^{\circ}\text{C}$), enabling or disabling the units indicator (ON/OFF), or setting the display resolution (XXXXXX, XXXXX.X or XXXX.XX).

To change the engineering units:

1. Press the MENU key until the display reads "RDG.CNF."
2. Press the MIN key until the display reads "RDG.5."
3. Set this parameter as desired using the MAX key ("0"= $^{\circ}\text{C}$, "1"= $^{\circ}\text{F}$, "2"= $^{\circ}\text{K}$).
4. Press MENU to store the settings.
5. Press RESET twice to save settings and return to normal operation mode.

To turn the engineering units indicator on or off:

1. Press the MENU key until the display reads "RDG.CNF."
2. Press the MIN key until the display reads "RDG.6."
3. Set this parameter as desired using the MAX key ("0"=units not displayed, "1"=units displayed).
4. Press MENU to store the settings.
5. Press RESET twice to save settings and return to normal operation mode.

To select the display resolution:

1. Press the MENU key until the display reads "DEC PT."
2. Press the MAX key to choose the desired resolution (FFFFFF, FFFFF.F, or FFFF.FF).
3. Press MENU to store the settings.
4. Press RESET twice to save settings and return to normal operation mode.

3.6 Target Cavity Temperature Transition Table

The BB705 heat-up and cool-down characteristics are illustrated in the following table. The table illustrates the approximate time required to make a transition from one heater cavity temperature to another. First, determine the current heater cavity temperature and go to the corresponding row. Now, decide the new heater cavity temperature and go to the appropriate column. Note that there are X's along the diagonal where original and target heater cavity temperatures are the same.

TO: FROM:		
TEMPERATURE		100 (212)
	100 (212)	

Figure 8. Approximate Target Plate Temperature Transition Times

Section 4 - RS232 Communications

The controller and reference meter provides for bi-directional data transfer via a three conductor cable consisting of signal ground, receive input, and transmit output. It is **recommended that less than fifty feet of shielded cable be used between the computer and this instrument. This will assure performance of the BB705 to EN61326 standards, under the E.M.C.** Note that multiple instruments cannot be tied to the same port in this configuration. The RS232 port is optically isolated to eliminate ground loop problems.

In Figure 9 is a pinout diagram for the serial port of the BB705 as well as the pinout for a 9-pin PC serial port. Use a straight DB9 (female) to DB9 (male) connector cable to connect your computer to the BB705. The cable should be attached only when the computer and BB705 are off.

Only parameters in the parameter list should be modified or queried via the serial port. Other parameters should be viewed or queried from the controller, directly. It is highly recommended that baud rate for the controller be modified on the controller, directly. Note that both the BB705 and the computer must be communicating with the same serial communications parameters to establish a working communication link.

The serial communications feature can be tested using terminal emulation package. Note that this controller does not time out waiting for the next character to be transmitted. Be sure not to use the XON/XOFF or hardware handshaking. Lastly, it should be noted that following a complete transmission to the BB705, a response it sent back. If the message was valid, the changed or queried parameter is echoed back (following the same format). If the message was not according to acceptable format or was attempting to force a parameter out of range, an "ERROR" message is echoed.

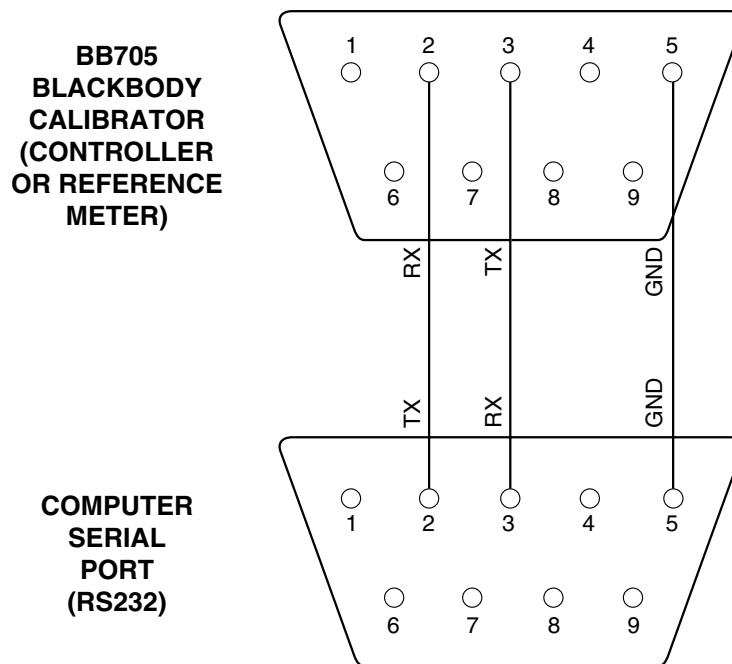

Figure 9. Connecting a PC to the BB705's Controller/Reference Meter Serial Port

Parameter List (only relevant parameters shown):

<u>PAR#:</u>	<u>Parameter:</u>	<u>Range/Units:</u>
00	Process Temp.	Input determined
01	Setpoint	Input determined
19	Baud Selection	bAUd

Baud Selections:

<u>Code:</u>	<u>Baud:</u>	<u>Parity:</u>	<u>Data Bits:</u>	<u>Stop Bits:</u>
3.o.7	300	odd	7	2
6.o.7	600	odd	7	2
12.o.7	1200	odd	7	2 (factory default settings)
24.o.7	1200	odd	7	2
3.n.8	300	no	8	1
6.n.8	600	no	8	1
12.n.8	1200	no	8	1
24.n.8	2400	no	8	1

General Message Format:

#[controller id][command][parameter number]<new value><units>[CR/LF]

Definitions:

- This character initiates an "escape sequence" that the controller will recognize.

[controller id] – Up to 2 numeric characters, "00" to "99" (factory default="01")

[command] – 1 character, upper case or lower case

"R" – To read a parameter from the controller

"M" – To temporarily modify a controller parameter (lost upon shutdown)

"E" – To modify a controller param. in non-volatile mem. (saved even after shutdown)

[parameter #] – Up to 2 numeric characters, "00" to "99"

<new value> - This control word is used only when entering or modifying a parameter. Up to 6 characters may be entered. The first character can be a space, a "+", or a "-". The next 4 characters are for entering the new value parameter value. Be sure to use the exact same field format as is currently being used. (i.e. if the XXX.X format is used to express temperature, be sure to enter a new value that conforms to the same format).

<units> - This optional control word is used to specify units, F for °F, C for °C.

[CR/LF] – Every transmission must be terminated with a carriage return [CR] character. The line feed [LF] character is optional.

Section 5 - Maintenance

5.1 Calibration

This unit has been fine tuned at the factory and calibrated to give optimum performance of its full temperature range. It is recommended that the unit be returned annually for re-calibration.

5.2 Cleaning

CAUTION:

Remove all electrical connections and power before attempting any maintenance or cleaning. Only suitably trained service persons should perform maintenance or cleaning on the BB705.

5.2.1 Main Body

Only a damp, soft rag with a mild cleaning solution should be used when cleaning the main body of this unit.

5.2.2 Heater Cavity

Do not attempt to clean the heater cavity through conventional means. The only type of cleaning the cavity may need is the removal of some soot after burn in. This fine grain soot can be vacuumed out of the cavity.

CAUTION:

When removing soot from heater cavity, be sure to wear protective goggles. NEVER REMOVE SOOT FROM A HOT OR WARM CAVITY! Be sure unit has cooled to room temperature and is disconnected from power source before vacuuming out the soot. Never touch the cavity with your hand, tools or brushes.

5.2.3 Fan

The fan guard should be cleaned as a minimum annually by using a compressed air source.

5.3 Fuse replacement

WARNING:

Disconnect all power from source before attempting fuse replacement.

CAUTION:

For continued protection against the risk of fire replace with only the same size, type and rating fuse indicated here and on the rear panel of your unit.

For model: **BB705 use** 1 ea. 250 VAC~, T12A (Time-Lag, 12 A)
UL APPROVED ($\frac{1}{4}$ " dia. x $1\frac{1}{4}$ " long).



For model: **BB705 -230VAC use** 2 ea. 250 VAC~, T6.3A (Time-Lag, 6.3A)
VDE APPROVED (5 mm dia. x 20 mm long).

Note that for the **BB705-230VAC** both fuses need to be checked if there is a suspicion that a fuse has been blown. One or both fuses may have been damaged.

Section 6 - Specifications

Heater Cavity Temperature Range:	100°C to 1046°C (212°F to 1915°F)
Ambient Environmental Conditions:	
Temperature:	0°C to 35°C (32°F to 95°F)
Humidity:	0 to 90% RH, non-condensing
Power:	
BB705	115 VAC~, 50/60 Hz, 1100W
BB705-230VAC	230 VAC~, 50/60 Hz, 1100W
Internal Control Sensor:	Platinum Thermocouples
Accuracy:	±1°C, ±0.25% rdg (±1.8°F, ±0.25% rdg)
Ref. Meter Display Accuracy:	±0.06°C (over entire range)
Resolution:	0.01° (on temperature reference meter)
Overall System Stability:	±0.4°C per 8-hr. period
Target Plate Emissivity:	0.99
Cavity Aperture Diameter:	44.4 mm (1.75")
Heat-Up Time:	80 minutes from 100°C to 1000°C (from 212°F to 1832°F)
Dimensions:	566 W x 520 H x 600 D (22.3 W x 20.5 H x 23.6" D)
Weight:	31 kg. (68 lb.)
Installation Category II	

Section 7 - Troubleshooting Guide

Problem	Solution
1. Unit will not turn on.	a. Check all electrical connections. b. Check rear panel fuses. c. Unit requires service, contact our customer service department.
2. Unit turns on but the target plate will not get hot.	a. Check that you have entered a will setpoint above the ambient temperature. b. Verify that the controller is set to its factory default settings. c. Unit requires service, contact our customer service department. d. Unit has been operated outside of operating range. Safety cutoff switch has disabled heater. Unit should be sent back to factory for reset and safety check.
3. Controller display shows "Error" and the target plate will not get hot or cold.	a. Unit requires service, contact our customer service department.
4. Target plate temperature will not stabilize to within $\pm 0.5^{\circ}\text{F}$ of the setpoint temperature.	a. Verify that the controller is set to its factory default settings. b. Unit requires service, contact our customer service department.
5. Controller has no output. Pressing buttons has No effect. TUNE blinks on the display.	a. Controller may be in STANDBY mode. Hold down the  key continuously until "TUNE" stops blinking.
6. Controller has no output. Controller does not Respond to any keypresses.	a. Controller may be in LOCK mode. Hold down the  key continuously until "Ac.Cd" is displayed. Change to a menu level other than level 1 and exit the menu selection mode by pressing the  key once.

Section 8 - Glossary of Terms Used in This Manual

Blackbody

A theoretical object that radiates the maximum amount of energy at a given temperature, and absorbs all the energy incident upon it.

Calibration

The process of adjusting an instrument or compiling a deviation chart so that its reading can be correlated to the actual value being measured.

Emissivity

The ratio of energy emitted by a surface to the energy emitted by a blackbody at the same temperature.

IEC

International Electrotechnical Commission

Infrared (IR)

A range of the electromagnetic spectrum extending beyond red visible light from 760 nanometers to 1000 microns.

NIST

National Institute of Standards and Technology

PID

Proportional, Integral, Derivative. A three mode control action where the controller has time proportioning, integral (auto reset) and derivative rate action.

RTD

Resistance temperature detector

The OMEGA Family of Blackbody Calibrators

Listed below is a selection guide of OMEGA's current line of blackbody calibration sources in addition to the one you have selected. This family of rugged, portable and accurate calibrators cover a wide range of temperatures, target plate sizes and features making them perfect for infrared pyrometer field service testing and laboratory calibrations.

BB701 Hot/Cold Blackbody Calibration Source

Calibration Range: -18 to 149°C (0 to 300°F)

Emissivity: 0.95

Cavity Size: 63.5 mm (2.5 in.)

Accuracy: $\pm 0.8^{\circ}\text{C}$ ($\pm 1.4^{\circ}\text{F}$)

Ambient Temp.: 4 to 43°C (40 to 110°F)

Power: 115/230V, 50/60 Hz, 175W

BB702 Blackbody Calibration Source

Calibration Range: 32 to 215°C (amb. 90 to 420°F)

Emissivity: 0.95

Cavity Size: 63.5 mm (2.5 in.)

Accuracy: $\pm 0.5^{\circ}\text{C}$ ($\pm 0.9^{\circ}\text{F}$), $\pm 0.25\%$ rdg.

Ambient Temp.: 5 to 45°C (41 to 113°F)

Power: 115/230V, 50/60 Hz, 75W

BB703 Mini Blackbody Calibration Source

Calibration Range: 32 to 400°C (90 to 752°F)

Emissivity: 0.95

Cavity Size: 28.6 mm (1.125 in.)

Accuracy: $\pm 1.4^{\circ}\text{C}$ ($\pm 2.5^{\circ}\text{F}$)

Ambient Temp.: 0 to 40°C (32 to 104°F)

Power: 115/230V, 50/60 Hz, 175W

BB704 4" Target Plate Blackbody Calibration Source

Calibration Range: 100 to 400°C (212 to 752°F)

Emissivity: 0.95

Cavity Size: 101.6 mm (4 in.)

Accuracy: $\pm 0.8^{\circ}\text{C}$ ($\pm 1.4^{\circ}\text{F}$)

Ambient Temp.: 0 to 50°C (32 to 122°F)

Power: 115/230V, 50/60 Hz, 425W

BB705 Laboratory Grade Blackbody Calibration Source

Calibration Range: 100 to 1046°C (212 to 1915°F)

Emissivity: 0.99

Cavity Size: 44 mm (1.75 in.)

Accuracy: $\pm 1.0^{\circ}\text{C}$ ($\pm 1.8^{\circ}\text{F}$), $\pm 0.25\%$ rdg

Ambient Temp.: 0 to 35°C (32 to 95°F)

Power: 115/230V, 50/60 Hz, 1100W

BB-4A High Temperature Blackbody Calibration Source

Calibration Range: 100 to 982°C (212 to 1800°F)

Emissivity: 0.99

Cavity Size: 22.2 mm (0.88 in.)

Accuracy: $\pm 1.0^{\circ}\text{C}$ ($\pm 1.8^{\circ}\text{F}$), $\pm 0.25\%$ rdg

Ambient Temp.: 0 to 50°C (32 to 122°F)

Power: 115/230V, 50/60 Hz, 400W

For a complete, updated specification sheet and price on any of the calibrators listed here visit our website at www.omega.com. Please call our sales or customer service department for information and pricing on any new models available.



NOTES:

WARRANTY/DISCLAIMER

OMEGA ENGINEERING, INC. warrants this unit to be free of defects in materials and workmanship for a period of **25 months** from date of purchase. OMEGA's WARRANTY adds an additional one (1) month grace period to the normal **two (2) year product warranty** to cover handling and shipping time. This ensures that OMEGA's customers receive maximum coverage on each product.

If the unit malfunctions, it must be returned to the factory for evaluation. OMEGA's Customer Service Department will issue an Authorized Return (AR) number immediately upon phone or written request. Upon examination by OMEGA, if the unit is found to be defective, it will be repaired or replaced at no charge. OMEGA's WARRANTY does not apply to defects resulting from any action of the purchaser, including but not limited to mishandling, improper interfacing, operation outside of design limits, improper repair, or unauthorized modification. This WARRANTY is VOID if the unit shows evidence of having been tampered with or shows evidence of having been damaged as a result of excessive corrosion; or current, heat, moisture or vibration; improper specification; misapplication; misuse or other operating conditions outside of OMEGA's control. Components in which wear is not warranted, include but are not limited to contact points, fuses, and triacs.

OMEGA is pleased to offer suggestions on the use of its various products. However, OMEGA neither assumes responsibility for any omissions or errors nor assumes liability for any damages that result from the use of its products in accordance with information provided by OMEGA, either verbal or written. OMEGA warrants only that the parts manufactured by the company will be as specified and free of defects. OMEGA MAKES NO OTHER WARRANTIES OR REPRESENTATIONS OF ANY KIND WHATSOEVER, EXPRESSED OR IMPLIED, EXCEPT THAT OF TITLE, AND ALL IMPLIED WARRANTIES INCLUDING ANY WARRANTY OF MERCHANTABILITY AND FITNESS FOR A PARTICULAR PURPOSE ARE HEREBY DISCLAIMED. LIMITATION OF LIABILITY: The remedies of purchaser set forth herein are exclusive, and the total liability of OMEGA with respect to this order, whether based on contract, warranty, negligence, indemnification, strict liability or otherwise, shall not exceed the purchase price of the component upon which liability is based. In no event shall OMEGA be liable for consequential, incidental or special damages.

CONDITIONS: Equipment sold by OMEGA is not intended to be used, nor shall it be used: (1) as a "Basic Component" under 10 CFR 21 (NRC), used in or with any nuclear installation or activity; or (2) in medical applications or used on humans. Should any Product(s) be used in or with any nuclear installation or activity, medical application, used on humans, or misused in any way, OMEGA assumes no responsibility as set forth in our basic WARRANTY/DISCLAIMER language, and, additionally, purchaser will indemnify OMEGA and hold OMEGA harmless from any liability or damage whatsoever arising out of the use of the Product(s) in such a manner.

RETURN REQUESTS/INQUIRIES

Direct all warranty and repair requests/inquiries to the OMEGA Customer Service Department. BEFORE RETURNING ANY PRODUCT(S) TO OMEGA, PURCHASER MUST OBTAIN AN AUTHORIZED RETURN (AR) NUMBER FROM OMEGA'S CUSTOMER SERVICE DEPARTMENT (IN ORDER TO AVOID PROCESSING DELAYS). The assigned AR number should then be marked on the outside of the return package and on any correspondence.

The purchaser is responsible for shipping charges, freight, insurance and proper packaging to prevent breakage in transit.

FOR **WARRANTY** RETURNS, please have the following information available BEFORE contacting OMEGA:

1. Purchase Order number under which the product was PURCHASED,
2. Model and serial number of the product under warranty, and
3. Repair instructions and/or specific problems relative to the product.

FOR **NON-WARRANTY** REPAIRS, consult OMEGA for current repair charges. Have the following information available BEFORE contacting OMEGA:

1. Purchase Order number to cover the COST of the repair,
2. Model and serial number of the product, and
3. Repair instructions and/or specific problems relative to the product.

OMEGA's policy is to make running changes, not model changes, whenever an improvement is possible. This affords our customers the latest in technology and engineering.

OMEGA is a trademark of OMEGA ENGINEERING, INC.

© Copyright 2017 OMEGA ENGINEERING, INC. All rights reserved. This document may not be copied, photocopied, reproduced, translated, or reduced to any electronic medium or machine-readable form, in whole or in part, without the prior written consent of OMEGA ENGINEERING, INC.

Where Do I Find Everything I Need for Process Measurement and Control? **OMEGA...Of Course!** *Shop online at omega.com*

TEMPERATURE

- ☑ Thermocouple, RTD & Thermistor Probes, Connectors, Panels & Assemblies
- ☑ Wire: Thermocouple, RTD & Thermistor
- ☑ Calibrators & Ice Point References
- ☑ Recorders, Controllers & Process Monitors
- ☑ Infrared Pyrometers

PRESSURE, STRAIN AND FORCE

- ☑ Transducers & Strain Gages
- ☑ Load Cells & Pressure Gages
- ☑ Displacement Transducers
- ☑ Instrumentation & Accessories

FLOW/LEVEL

- ☑ Rotameters, Gas Mass Flowmeters & Flow Computers
- ☑ Air Velocity Indicators
- ☑ Turbine/Paddlewheel Systems
- ☑ Totalizers & Batch Controllers

pH/CONDUCTIVITY

- ☑ pH Electrodes, Testers & Accessories
- ☑ Benchtop/Laboratory Meters
- ☑ Controllers, Calibrators, Simulators & Pumps
- ☑ Industrial pH & Conductivity Equipment

DATA ACQUISITION

- ☑ Communications-Based Acquisition Systems
- ☑ Data Logging Systems
- ☑ Wireless Sensors, Transmitters, & Receivers
- ☑ Signal Conditioners
- ☑ Data Acquisition Software

HEATERS

- ☑ Heating Cable
- ☑ Cartridge & Strip Heaters
- ☑ Immersion & Band Heaters
- ☑ Flexible Heaters
- ☑ Laboratory Heaters

ENVIRONMENTAL MONITORING AND CONTROL

- ☑ Metering & Control Instrumentation
- ☑ Refractometers
- ☑ Pumps & Tubing
- ☑ Air, Soil & Water Monitors
- ☑ Industrial Water & Wastewater Treatment
- ☑ pH, Conductivity & Dissolved Oxygen Instruments