

Where Do I Find Everything I Need for Process Measurement and Control? **OMEGA...Of Course!**

Shop online at www.omega.com

TEMPERATURE

- ☑ Thermocouple, RTD & Thermistor Probes, Connectors, Panels & Assemblies
- ☑ Wire: Thermocouple, RTD & Thermistor
- ☑ Calibrators & Ice Point References
- ☑ Recorders, Controllers & Process Monitors
- ☑ Infrared Pyrometers

PRESSURE, STRAIN AND FORCE

- ☑ Transducers & Strain Gages
- ☑ Load Cells & Pressure Gages
- ☑ Displacement Transducers
- ☑ Instrumentation & Accessories

FLOW/LEVEL

- ☑ Rotameters, Gas Mass Flowmeters & Flow Computers
- ☑ Air Velocity Indicators
- ☑ Turbine/Paddlewheel Systems
- ☑ Totalizers & Batch Controllers

pH/CONDUCTIVITY

- ☑ pH Electrodes, Testers & Accessories
- ☑ Benchtop/Laboratory Meters
- ☑ Controllers, Calibrators, Simulators & Pumps
- ☑ Industrial pH & Conductivity Equipment

DATA ACQUISITION

- ☑ Data Acquisition & Engineering Software
- ☑ Communications-Based Acquisition Systems
- ☑ Plug-in Cards for Apple, IBM & Compatibles
- ☑ Datalogging Systems
- ☑ Recorders, Printers & Plotters

HEATERS

- ☑ Heating Cable
- ☑ Cartridge & Strip Heaters
- ☑ Immersion & Band Heaters
- ☑ Flexible Heaters
- ☑ Laboratory Heaters

ENVIRONMENTAL MONITORING AND CONTROL

- ☑ Metering & Control Instrumentation
- ☑ Refractometers
- ☑ Pumps & Tubing
- ☑ Air, Soil & Water Monitors
- ☑ Industrial Water & Wastewater Treatment
- ☑ pH, Conductivity & Dissolved Oxygen Instruments

1 YEAR
WARRANTY



User's Guide

Shop online at

[omega.com](http://www.omega.com)

Ω OMEGA®

www.omega.com

e-mail: info@omega.com

ISO 9001
CERTIFIED
CORPORATE QUALITY
STAMFORD, CT

ISO 9002
CERTIFIED
CORPORATE QUALITY
MANCHESTER, UK

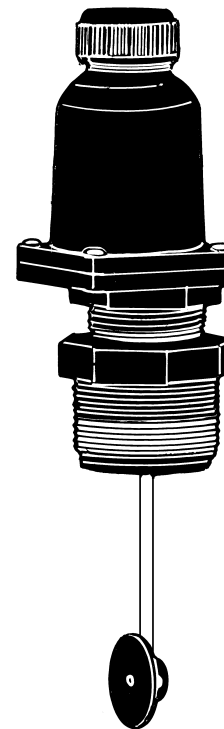

FSW-50 Series Industrial Flow Switches

M0772/0802



WARRANTY/DISCLAIMER

OMEGAnet® Online Service
www.omega.com

Internet e-mail
info@omega.com

Servicing North America:

USA: One Omega Drive, Box 4047
Stamford CT 06907-0047
Tel: (203) 359-1660 FAX: (203) 359-7700
e-mail: info@omega.com
ISO 9001 Certified

Canada: 976 Bergar
Laval (Quebec) H7L 5A1
Tel: (514) 856-6928 FAX: (514) 856-6886
e-mail: info@omega.com

For immediate technical or application assistance:

USA and Canada: Sales Service: 1-800-826-6342 / 1-800-TC-OMEGA®
Customer Service: 1-800-622-2378 / 1-800-622-BEST®
Engineering Service: 1-800-872-9436 / 1-800-USA-WHEN®
TELEX: 996404 EASYLINK: 62968934 CABLE: OMEGA

Mexico: En Español: (001) 203-359-7803 e-mail: espanol@omega.com
FAX: (001) 203-359-7807 info@omega.com.mx

Servicing Europe:

Benelux: Postbus 8034, 1180 LA Amstelveen, The Netherlands
Tel: +31 (0)20 3472121 FAX: +31 (0)20 6434643
Toll Free in Benelux: 0800 0993344
e-mail: sales@omegaeng.nl

Czech Republic: Rudé armády 1868, 733 01 Karviná 8
Tel: +420 (0)69 6311899 FAX: +420 (0)69 6311114
Toll Free: 0800-1-66342 e-mail: info@omegashop.cz

France: 11, rue Jacques Cartier, 78280 Guyancourt, France
Tel: +33 (0)1 61 37 29 00 FAX: +33 (0)1 30 57 54 27
Toll Free in France: 0800 466 342
e-mail: sales@omega.fr

Germany/Austria: Daimlerstrasse 26, D-75392 Deckenpfronn, Germany
Tel: +49 (0)7056 9398-0 FAX: +49 (0)7056 9398-29
Toll Free in Germany: 0800 639 7678
e-mail: info@omega.de

United Kingdom: One Omega Drive, River Bend Technology Centre
Northbank, Irlam, Manchester
M44 5BD United Kingdom
Tel: +44 (0)161 777 6611 FAX: +44 (0)161 777 6622
Toll Free in United Kingdom: 0800-488-488
e-mail: sales@omega.co.uk
ISO 9002 Certified

It is the policy of OMEGA to comply with all worldwide safety and EMC/EMI regulations that apply. OMEGA is constantly pursuing certification of its products to the European New Approach Directives. OMEGA will add the CE mark to every appropriate device upon certification.

The information contained in this document is believed to be correct, but OMEGA Engineering, Inc. accepts no liability for any errors it contains, and reserves the right to alter specifications without notice.

WARNING: These products are not designed for use in, and should not be used for, patient-connected applications.

OMEGA ENGINEERING, INC. warrants this unit to be free of defects in materials and workmanship for a period of **13 months** from date of purchase. OMEGA's Warranty adds an additional one (1) month grace period to the normal **one (1) year product warranty** to cover handling and shipping time. This ensures that OMEGA's customers receive maximum coverage on each product.

If the unit malfunctions, it must be returned to the factory for evaluation. OMEGA's Customer Service Department will issue an Authorized Return (AR) number immediately upon phone or written request. Upon examination by OMEGA, if the unit is found to be defective, it will be repaired or replaced at no charge. OMEGA's WARRANTY does not apply to defects resulting from any action of the purchaser, including but not limited to mishandling, improper interfacing, operation outside of design limits, improper repair, or unauthorized modification. This WARRANTY is VOID if the unit shows evidence of having been tampered with or shows evidence of having been damaged as a result of excessive corrosion; or current, heat, moisture or vibration; improper specification; misapplication; misuse or other operating conditions outside of OMEGA's control. Components which wear are not warranted, including but not limited to contact points, fuses, and triacs.

OMEGA is pleased to offer suggestions on the use of its various products. However, OMEGA neither assumes responsibility for any omissions or errors nor assumes liability for any damages that result from the use of its products in accordance with information provided by OMEGA, either verbal or written. OMEGA warrants only that the parts manufactured by it will be as specified and free of defects. OMEGA MAKES NO OTHER WARRANTIES OR REPRESENTATIONS OF ANY KIND WHATSOEVER, EXPRESS OR IMPLIED, EXCEPT THAT OF TITLE, AND ALL IMPLIED WARRANTIES INCLUDING ANY WARRANTY OF MERCHANTABILITY AND FITNESS FOR A PARTICULAR PURPOSE ARE HEREBY DISCLAIMED. LIMITATION OF LIABILITY: The remedies of purchaser set forth herein are exclusive, and the total liability of OMEGA with respect to this order, whether based on contract, warranty, negligence, indemnification, strict liability or otherwise, shall not exceed the purchase price of the component upon which liability is based. In no event shall OMEGA be liable for consequential, incidental or special damages.

CONDITIONS: Equipment sold by OMEGA is not intended to be used, nor shall it be used: (1) as a "Basic Component" under 10 CFR 21 (NRC), used in or with any nuclear installation or activity; or (2) in medical applications or used on humans. Should any Product(s) be used in or with any nuclear installation or activity, medical application, used on humans, or misused in any way, OMEGA assumes no responsibility as set forth in our basic WARRANTY/DISCLAIMER language, and, additionally, purchaser will indemnify OMEGA and hold OMEGA harmless from any liability or damage whatsoever arising out of the use of the Product(s) in such a manner.

RETURN REQUESTS/INQUIRIES

Direct all warranty and repair requests/inquiries to the OMEGA Customer Service Department. BEFORE RETURNING ANY PRODUCT(S) TO OMEGA, PURCHASER MUST OBTAIN AN AUTHORIZED RETURN (AR) NUMBER FROM OMEGA'S CUSTOMER SERVICE DEPARTMENT (IN ORDER TO AVOID PROCESSING DELAYS). The assigned AR number should then be marked on the outside of the return package and on any correspondence.

The purchaser is responsible for shipping charges, freight, insurance and proper packaging to prevent breakage in transit.

FOR **WARRANTY** RETURNS, please have the following information available BEFORE contacting OMEGA:

1. Purchase Order number under which the product was PURCHASED,
2. Model and serial number of the product under warranty, and
3. Repair instructions and/or specific problems relative to the product.

FOR **NON-WARRANTY** REPAIRS, consult OMEGA for current repair charges. Have the following information available BEFORE contacting OMEGA:

1. Purchase Order number to cover the COST of the repair,
2. Model and serial number of the product, and
3. Repair instructions and/or specific problems relative to the product.

OMEGA's policy is to make running changes, not model changes, whenever an improvement is possible. This affords our customers the latest in technology and engineering.

OMEGA is a registered trademark of OMEGA ENGINEERING, INC.

© Copyright 2002 OMEGA ENGINEERING, INC. All rights reserved. This document may not be copied, photocopied, reproduced, translated, or reduced to any electronic medium or machine-readable form, in whole or in part, without the prior written consent of OMEGA ENGINEERING, INC.

General Description

The OMEGA® FSW-50 Series Flow Switches feature a 15A SPDT switch and an internal screw adjustment which provides continuous switch point adjustment while in operation in-line. Multiple drag disks are supplied with each unit to provide incremental switch point adjustment. Their non-magnetic design makes them ideal for applications where rust is a problem. The FSW-50 comes standard in a plastic/316SS construction. The FSW-50 Series is also available in a special PPS* Hastelloy C and Viton construction.

The FSW-50 Series are for use in highly particle-contaminated liquids such as sewage, machine cutting oils and medium slurries. The standard models can be used in mildly corrosive liquids such as low to medium concentration acids and bases; sea water, sewage oils; rusty coolant water, etc. The special PPS* Hastelloy C and Viton construction models are for use in concentrated corrosive liquids such as sulfuric, nitric, hydrochloric and acetic acids; ferric chloride; aqueous ammonia; benzene; magnesium chloride, etc.

Particle contamination resistance is provided by a flexible filter boot which prevents crystallization, caking, heavy dirt concentration, slurries, scum, etc., from affecting the operation of the flow detector. The FSW-50 Series Switches respond to flow only, independent of line pressure, temperature and environment.

During emergency conditions these switches signal catastrophic system failures such as line breakage; pump failure; incorrect valve opening or closing; pipe, valve or filter clogging, etc.

PPS* = polyphenylene sulfide plastic

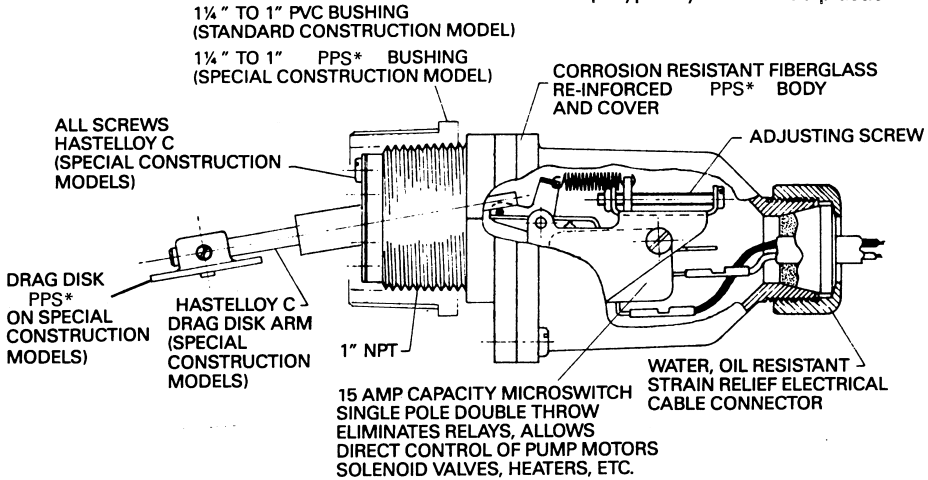

PPS*= polyphenylene sulfide plastic

Specifications

FLOW RANGE (water calibrated @ 70°F)

The maximum flow range flexibility is provided by three adjustment options:

1. Continuous adjustment while operating via a calibrated FORCE/BALANCE spring.
2. Step incremental adjustment via drag disk size change.
3. Continuous adjustment via moment arm change.

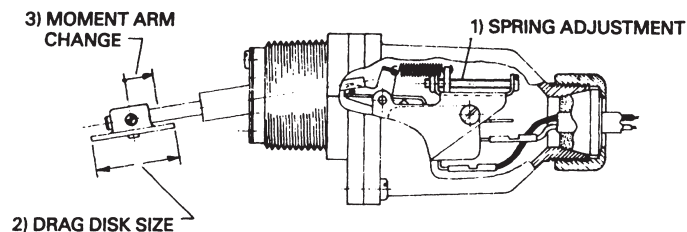

Available Drag Disks

The FSW-50 Series Switches come with three different drag disks. The drag disks are sized as follows:

DRAG DISK	SIZE
#1	.5" dia.
#2	.83" dia.
#3	1.0" dia.

The following table lists flow adjustment limits for various pipe sizes relative to Model No. and drag disk size. The moment arm (see Step 3 of FLOW RANGE) is held constant at the maximum value. Decreasing the moment arm, increases the adjustment range.

Low Flow Model Number	Nominal Low Flow Cont. Adj. Range (GPM)	Pipe Size (Ins.)	Nominal High Flow Cont. Adj. Range (GPM)	High Flow Model Number	% Increase of Listed Flows via Moment Arm Adj.	
FSW-50 w/drag disk #2 Shortest drag disk arm. Mid. size drag disk	*** 8-13	1	*** 18-28	FSW-50 w/drag disk #1 Shortest drag disk arm. Smallest drag disk	None	
	3.3-5.3 ft/sec		7.4-11.5 ft/sec			
FSW-51 w/drag disk #3 Mid. size drag disk arm. Largest drag disk	15-30 25-50 40-80	1½ 2 2½	30-60 50-105 80-155	FSW-51 w/drag disk #1 Mid. size drag disk arm. Smallest drag disk	None	
	2.7-5.4 ft/sec		5.4-10.8 ft/sec			
FSW-52 w/drag disk #3 Longest drag disk arm. Largest drag disk	40-90 60-120 75-155	3 3½ 4	90-180 120-240 155-310	FSW-52 w/drag disk #1 Longest drag disk arm. Smallest drag disk	+25%	
	120-245 180-350 300-600 500-950		5 6 8 10			245-480 350-700 600-1200 950-1900
	2.4-4.0 ft/sec		4.0-8.0 ft/sec			

* Force/Balance spring relaxed.
**Force/Balance spring fully extended.

Relay Switch:	SPDT 15A @ 125 or 250 Vac, 10,000,000 operations median
Nominal Sensitivity (% Flow Change to Activate Switch):	Approximately 10% @ upper end of range; approximately 30% @ lower end of range
Differential Pressure Drop Across Unit:	(Under normal operating conditions) 1"-3" pipe, less than 0.5 PSI; 4"-10" pipe, negligible
Working Line Pressure:	For standard construction model: 100 PSIG at 150°F; for special PPS*, Hastelloy C and Viton construction model: 100 PSIG at 200°F
Maximum Continuous Temperature:	Standard construction: 150°F; special construction: 200°F
Wetted Parts:	Standard construction PPS*, 316 SS, Viton PVC; Special construction: PPS*, Hastelloy C and Viton
Electrical Cable Fitting:	Water resistant for cable diameters .250" ±0.25"
Weight:	0.25 lb.

PPS* = polyphenylene sulfide plastic

Installation Dimensions

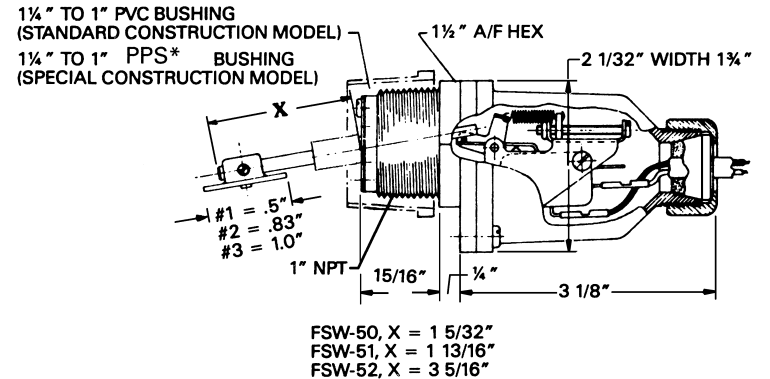

INSTALLATION WARNING

THE 1 1/2" X 1 1/4" PVC BUSHING (WHITE OR GRAY) SUPPLIED WITH THE FSW-50 SERIES CAN BE CRACKED IF THE CENTER BODY IS FIRST TIGHTENED INTO THE BUSHING. CRACKING PROBABILITY IS REDUCED IF THE BUSHING IS FIRST TIGHTENED INTO THE PIPE OR TANK FITTING AND THEN THE CENTER BODY TIGHTENED INTO THE BUSHING. THUS:

STEP 1: THREAD AND TIGHTEN THE PVC BUSHING INTO THE PIPE OR TANK FITTING.
 STEP 2: THREAD AND TIGHTEN THE CENTER BODY INTO THE PVC BUSHING.

ASSEMBLY WARNING

THE FSW-50 SERIES SWITCHES EMPLOY AN EXTERNAL SEAL SHAFT (A) A FLEXIBLE ELASTOMER DIAPHRAGM SEAL (B) AND AN INTERNAL FEED THRU SHAFT OR SWITCH ACTUATING ARM (D). ALL THREE ELEMENTS ARE ASSEMBLED AND LOCKED IN PLACE WITH LOCTITE ADHESIVE. TO PREVENT RUPTURE OF SEAL AND LEAKAGE INTO SWITCH AREA, IT IS CRITICALLY IMPORTANT THAT TORQUE NOT BE APPLIED TO SEAL SHAFT (A), FLOAT SHAFT (E) OR DRAG DISK ARM (E) DURING CHANGE OF FLOAT OR DRAG DISK.

IF FLOAT SHAFT OR DRAG DISK ARM (E) REQUIRE REPLACEMENT IT IS NECESSARY TO REMOVE FILTER BOOT (F). SEAL SHAFT (A) MUST THEN BE HELD FIRMLY IN A VISE OR WITH PLIERS WHILE (E) IS UNTHREADED AND A NEW SHAFT IS ASSEMBLED.

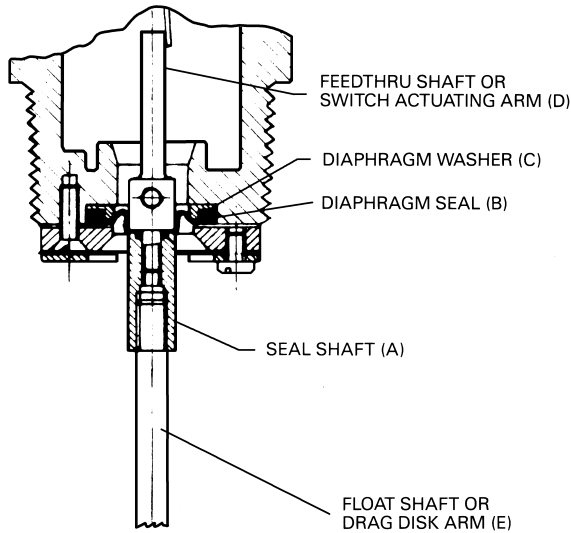

Installation

The FSW-50 Series Fluid Flow Switch is supplied with a 1 1/4" x 1" PVC TT bushing (standard construction model) or 1 1/4" x 1" PPS* bushing (special PPS* Hastelloy C and Viton construction model) threaded in place with 2 to 3 wraps of Teflon tape, which must be intact or renewed if bushing and switch are separated before assembly in tank. Care must be exercised when threading the bushing into plastic or metal fittings.

Apply a minimum of 2 to a maximum of 3 wraps of Teflon tape to threads of bushing – this is especially important if unit is to be used in metal fittings where coarse metal threads could gall plastic if not lubricated.

The plastic bushing CAN BE CRACKED if the main body of the flow switch is tightened into it FIRST. Cracking will not occur if the bushing is FIRST tightened into the pipe or tank fitting and THEN the body is tightened into the bushing.

PPS* = polyphenylene sulfide plastic

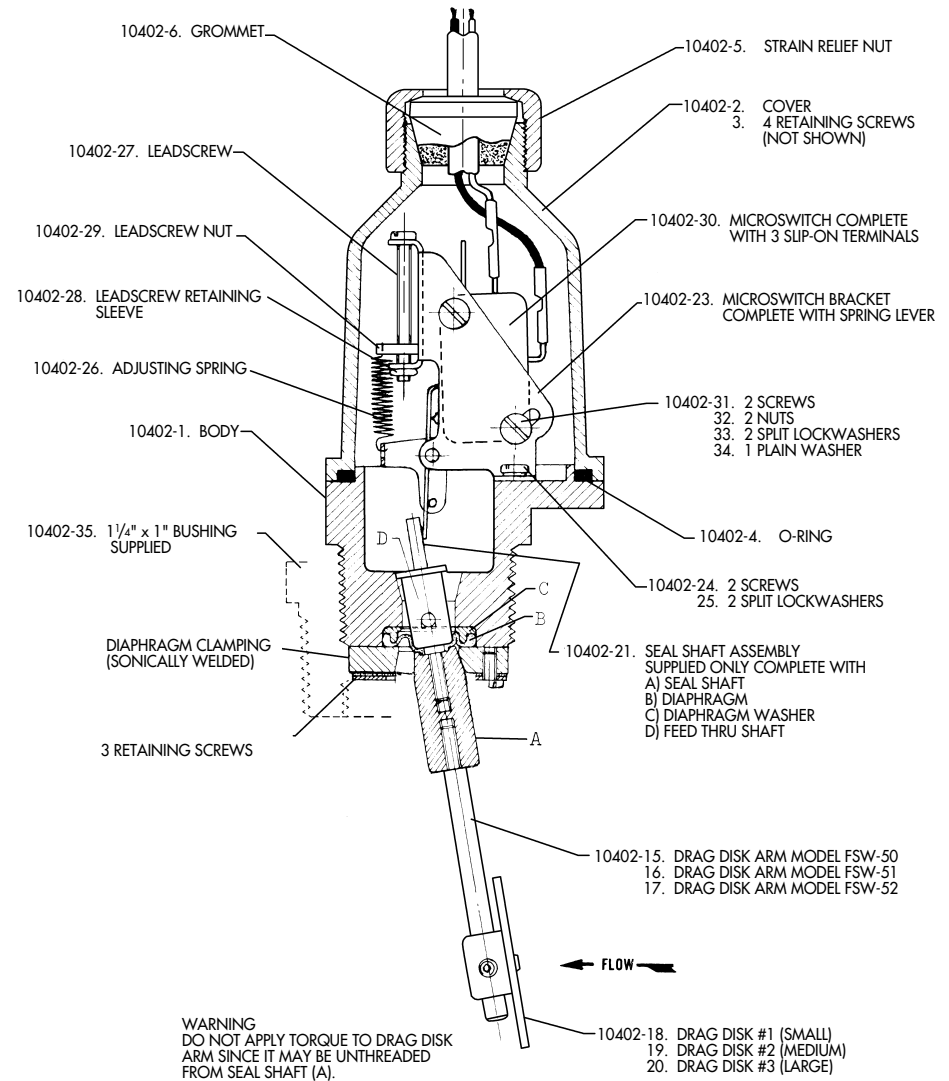

FSW-50 Series w/Special Ryton R-4, Hastelloy C and Viton Construction Parts Diagram

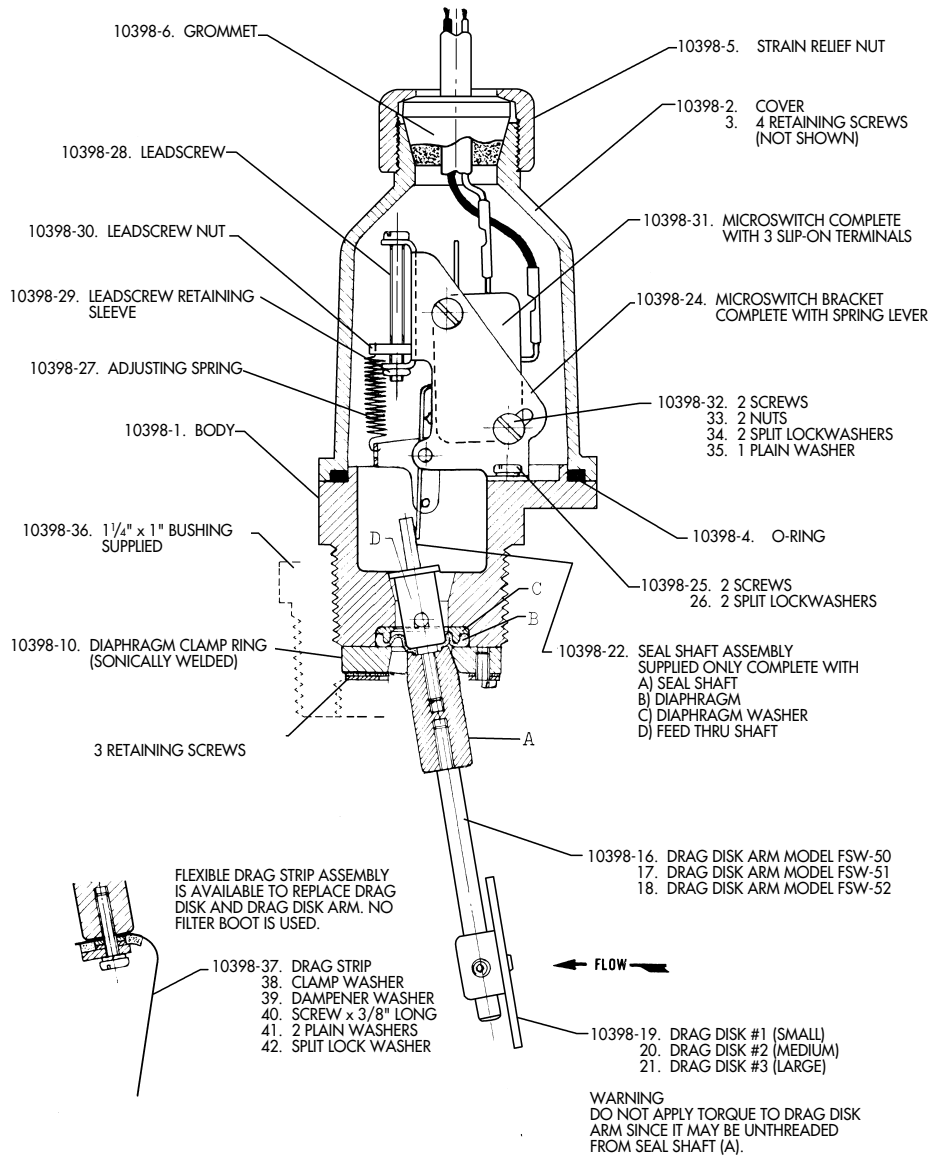

FSW-50 Series w/Standard Construction Parts Diagram

- Thus:
1. Teflon tape thread and tighten the plastic bushing into the pipe or tank fitting.
 2. Teflon tape thread and tighten the switch into the PLASTIC bushing by applying a wrench to the hexagon section. Repeat steps 1 and 2 until the ARROW on the body points in the DIRECTION OF FLOW and threads are leak tight.

NOTE

Plumber's tools such as pipe wrenches are not recommended. If possible, use a 'Rigid' type wrench where the smooth jaws closely fit the hexagon section.

Electrical Wiring

1. Remove gland nut, grommet and switch cover.
2. Strip outer jacket of electrical cord back approximately 1 1/4 inches. Strip insulation from individual conductors back approximately 1/4 inch.
3. Slip on terminals are supplied with each switch. Remove from switch terminals and crimp on or solder to electrical leads.
4. Feed electrical cable through gland nut, grommet and switch cover as shown.

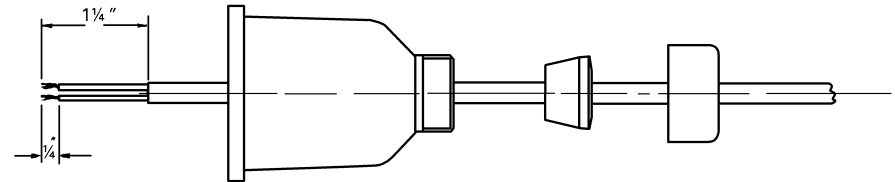

5. Apply slip on terminals to appropriate contacts of microswitch.
6. Slide the cover down the cable and fasten to the body of the switch with 4 screws provided.
7. Slide the grommet down the cable until the outer jacket is level with the small end of the grommet.
8. Push the grommet into the tapered end of the cover. Hold the cable jacket to prevent rotation and thread the gland nut firmly on to the cover.

Figure 1: Wiring Schematic for power applied to the load when the flow level is less than set point (power to load interrupted when flow increases to above set point).

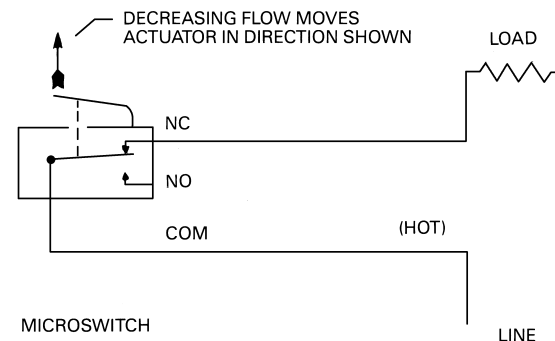
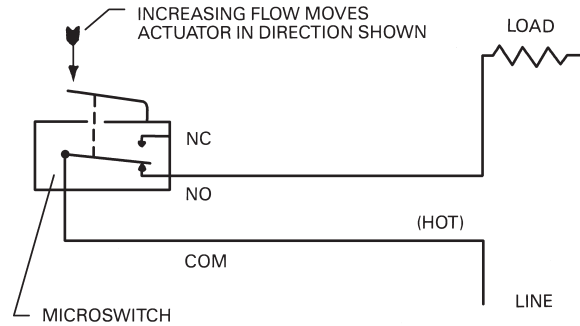

Figure 2: Wiring Schematic for power applied to load when the flow is greater than set point (power to load interrupted when flow decreases to below set point).



Switch Point Adjustment

1. Thread the unit into line while observing the following precautions:
 - a) Use appropriate adapters to keep the body of the switch from projecting into the flow stream.
 - b) Inspect to make sure that the drag disk does not touch the opposite wall of a small diameter pipe.
 - c) Use Teflon tape to seal the threads and lubricate to allow the arrow on the body to be aligned with the flow.
2. After aligning the arrow with flow, adjust the flow in the system to the desired rate without regard to the FSW-50 Series switch point setting.
3. The Switch Point Adjusting Mechanism consists of a leadscrew, a leadscrew nut and a helical spring.

CLOCKWISE rotation of the adjusting screw changes the microswitch actuation point toward HIGHER flow rates. COUNTERCLOCKWISE rotation changes the microswitch actuation point toward LOWER flow rates.

NOTE

All FSW-50 Series Switches are factory set at the lower end of the flow range, i.e., the adjusting screw is set at the low flow COUNTERCLOCKWISE position.

The leadscrew nut locks the adjusting screw in position, maintaining the flow set point under all environmental conditions.

4. Turn the adjusting screw in a clockwise direction until the microswitch is actuated while maintaining the desired fluid flow rate in the system. Turn the adjusting screw two additional turns in the clockwise direction and then slowly back off in a counterclockwise direction until microswitch is again actuated. The FSW-50 Flow Switch is now set for maximum sensitivity for detecting small flow changes.
5. Microswitch actuation point may be monitored during the adjustment procedure detailed in Step 4 above by an audible click or with an OHM meter before connecting line power or by monitoring the voltage supplied to the load through the microswitch.

6. If the system flow rate is changed, the FSW-50 can be adjusted to monitor the new flow rate by turning the adjusting screw in a counterclockwise direction to the minimum flow position and then proceeding as in Step 4 above.
7. In the event that the system flow is at the desired rate and the adjustment mechanism runs out of travel, i.e., the leadscrew nut is at either end of the support bracket before the microswitch is actuated, then the drag disk must be changed to shift the flow range so that it straddles the system flow rate.

EXAMPLE: If the FSW-50 is fitted with a No. 1 drag disk and the procedure in Step 4 has been followed, the adjusting screw has been turned counterclockwise until the leadscrew nut is at the extreme end of the support bracket (spring fully relaxed) and the microswitch still has not been actuated, then the flow is too low and a larger drag disk will have to be substituted for the drag disk #1 and the procedure in Step 4 repeated. If the No. 2 disk will not allow switch actuation via the procedure in Step 4, substitute disk No. 3.

The opposite procedure is used if the flow is so high that full extension of the spring cannot counterbalance the fluid forces on the drag disk and the switch remains actuated. Proceed by using a smaller drag disk, e.g., replace No. 3 with a No. 2, or a No. 2 with a No. 1 until the procedure in Step 4 can be accomplished.

Adjusting the moment arm can be employed after adjustment by the spring and changing drag disk sizes have been tried to no avail. Adjusting the moment arm consists of moving the drag disk along the arm thereby changing the force-balance moment arm. Moving a drag disk to the far end of the arm lowers the flow rate required to activate the switch. Moving a drag disk towards the filter boot increases the flow rate required to activate the switch.

NOTE

It is necessary throughout all installation and adjustment procedures to check to ensure that the drag disk is perpendicular to the flow and does not touch any interior surface throughout its complete fore and aft travel.