

2 YEAR
WARRANTY



Ω OMEGA® **User's Guide**



Shop online at
omega.comSM

e-mail: info@omega.com
For latest product manuals:
www.omegamanual.info

ZW-ED

ZW Series Wireless End Device



omega.com info@omega.com

Servicing North America:

U.S.A.:

Omega Engineering, Inc.,

Toll-Free: 1-800-826-6342 (USA & Canada only)

Customer Service: 1-800-622-2378 (USA & Canada only)

Engineering Service: 1-800-872-9436 (USA & Canada only)

Tel: (203) 359-1660 Fax: (203) 359-7700

e-mail: info@omega.com

For Other Locations Visit omega.com/worldwide

Table of Contents

NOTES, WARNINGS AND CAUTIONS	3
PART 1: INTRODUCTION	4
1.1 SAFETY AND EMC CONSIDERATIONS	4
<i>ESD Warning:</i>	4
<i>EMC Considerations:</i>	4
1.2 BEFORE YOU BEGIN	4
<i>Inspecting Your Shipment:</i>	4
<i>Manuals / Software:</i>	4
1.3 INCLUDED WITH YOUR ZW-REC	5
1.4 DESCRIPTION	6
PART 2: HARDWARE	7
2.1 ZW-ED DIAGRAM.....	7
2.2 DIP SWITCHES.....	8
<i>Setting the Network ID:</i>	8
<i>Setting the Device ID:</i>	9
2.3 POWER BUTTON	11
2.4 DIMENSIONS AND MOUNTING	11
PART 3: INITIAL SETUP	12
3.1 ANTENNA WARNING.....	12
3.2 CHOOSING A WIRELESS NETWORK ID.....	12
3.3 CHOOSING A DEVICE ID	12
3.4 CONNECTING YOUR SENSORS.....	12
3.5 POWERING THE UNIT	14
<i>Batteries</i>	14
<i>Coin Cell</i>	14
<i>Line Power</i>	15
3.6 START UP AND ENUMERATION.....	15
PART 4: SPECIFICATIONS	16
4.1 WIRELESS COMMUNICATIONS.....	16
4.2 POWER.....	16
<i>Input Power:</i>	16
<i>Batteries (Included):</i>	16
<i>Safety Qualified AC Power Adaptor (Optional):</i>	16
4.3 ENVIRONMENTAL	16
4.4 GENERAL	16
4.5 BATTERY LIFE.....	16
4.6 POWER CONNECTOR (OPTIONAL).....	16
APPENDIX A: RF TOPICS	17
<i>RF Channel Selection</i>	17
<i>Signal Strength Indicator</i>	17
<i>Maximizing Range</i>	18
APPENDIX B: WIRELESS CERTIFICATIONS	19
FEDERAL COMMUNICATION COMMISSION INTERFERENCE STATEMENT	19
INDUSTRY CANADA STATEMENT	19
CE STATEMENT.....	19
APPENDIX C: SAFETY & REGULATORY COMPLIANCE	20
<i>Safety:</i>	20
<i>EMC:</i>	20
<i>Radio:</i>	20

CE:.....20
FCC / IC:.....20
FCC Radiation Exposure Statement:.....20

NOTES, WARNINGS and CAUTIONS

Information that is especially important to note is identified by the following labels:

- **NOTE**
- **WARNING or CAUTION**
- **IMPORTANT**
- **TIP**



NOTE: Provides you with information that is important to successfully setup and use the ZW-ED Wireless End Device.



CAUTION or WARNING: Tells you about the risk of electrical shock.



CAUTION, WARNING or IMPORTANT: Tells you of circumstances or practices that can affect the instrument's functionality and must refer to accompanying documents.



TIP: Provides you helpful hints.



PART 1: INTRODUCTION

1.1 Safety and EMC Considerations

ESD Warning:



Warning: The following parts of the unit are ESD sensitive:

- Antenna
- LCD display
- Metal connectors for signal and power
- Metal body of sensor probes

EMC Considerations:

- Whenever EMC is an issue, always use shielded cables.
- Never run signal and power wires in the same conduit.
- Use twisted-pair wires for differential signal connections.
- Install Ferrite Bead(s) on signal wires close to the instrument if EMC problems persist.
- Failure to follow all instructions and warnings may result in injury!

1.2 Before You Begin

Inspecting Your Shipment:

Remove the packing slip and verify that you have received everything listed. Inspect the container and equipment for signs of damage as soon as you receive the shipment. Note any evidence of rough handling in transit. Immediately report any damage to the shipping agent. The carrier will not honor damage claims unless all shipping material is saved for inspection. After examining and removing the contents, save the packing material and carton in the event reshipment is necessary.

If you need assistance, please contact the Customer Service Department nearest you.

Manuals / Software:

The latest User Manual as well as free software including iConnect and Omega Dashboard are available at the website listed on the cover page of this manual.

1.3 Included with Your ZW-REC

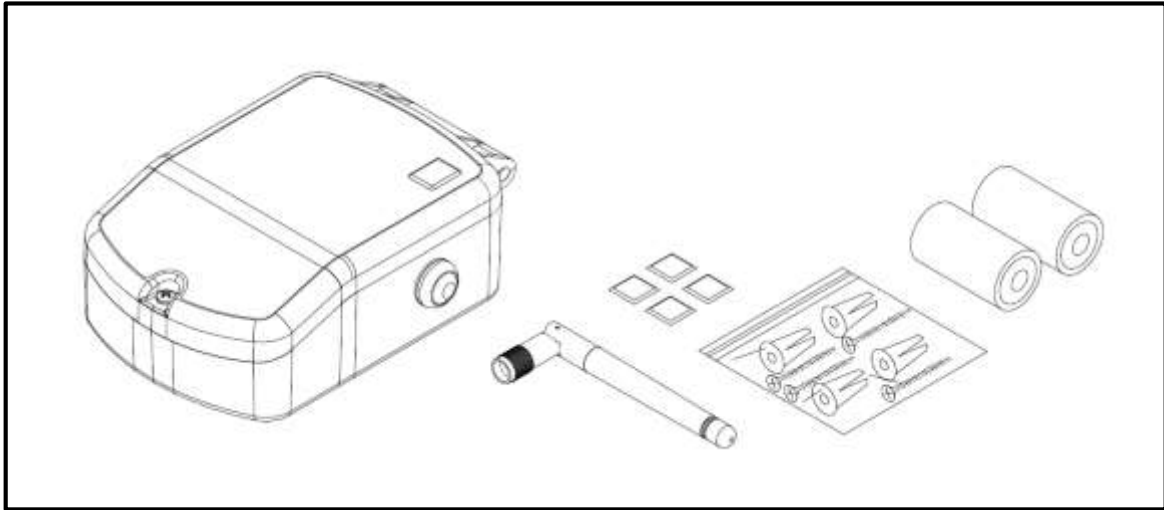

Figure 1.1: ZW-ED Included Items

- ZW-ED Wireless End Device
- 2.4GHz Antenna
- Mounting Kit including screws, anchors, mounting bracket and feet.
- CR2032 Battery (Pre-Installed)
- 2x C Cell Batteries

1.4 Description

The new, high-performance, long range, OMEGA® ZW-ED wireless End Device provides robust wireless environmental and process monitoring. The ZW-ED transmits to a Wireless Receiver, such as the new ZW-REC. The ZW-REC provides web-based monitoring of all of OMEGA's IEEE 802.15.4 compatible Wireless End Devices.

The ZW-ED is IEEE 802.15.4 compliant and operates at 2.4 GHz. It communicates over distances up to 1000m¹ (3280'). The ZW-ED monitors and transmits Temperature, Humidity, Light and Barometric Pressure. OMEGA offers a wide variety of compatible sensors to suit every application.

The ZW-ED can run off of 2 Cell Batteries for up to 7² years. For applications that require high update rates, or even longer up time, an optional AC adaptor is available. The ZW-ED also offers strong data assurance. The receipt of each reading is confirmed by the Receiver. If communication with the Receiver is lost the ZW-ED continues to record readings and transmits them the next time you connect to the network. Even if the ZW-ED loses power, the built in Real Time Clock (RTC) and RTC backup battery keep a consistent time base.

The ZW-ED is design to communicate with the all new ZW-REC. The ZW-REC offers greatly expanded functionality over previous wireless receivers. The ZW-REC can connect to up to 128 End Devices at once. The built in web server supports encryption to protect your sensitive data. The ZW-REC can also wirelessly update firmware for the ZW-ED and Compatible Sensors.

The ZW-REC is designed to require no software to setup and run. A standard web browser can be used to monitor and chart all sensor readings. The browser can also be used for all configuration of the ZW-ED. Firmware updates for the ZW-ED and compatible sensors can also all be loaded directly from the web browser.

Each ZW-REC receiver can support up to 128 ZW-ED End Devices and up to 8 receivers can be setup in one area allowing for networks of up to 1028 total End Devices. For large networks the Omega Dashboard web server software can be used to allow the monitoring of devices connected to different receivers from a single webpage.

¹ Without obstructions or interferences

² Battery life varied with update rate. See Battery Power Section.

PART 2: HARDWARE

2.1 ZW-ED Diagram

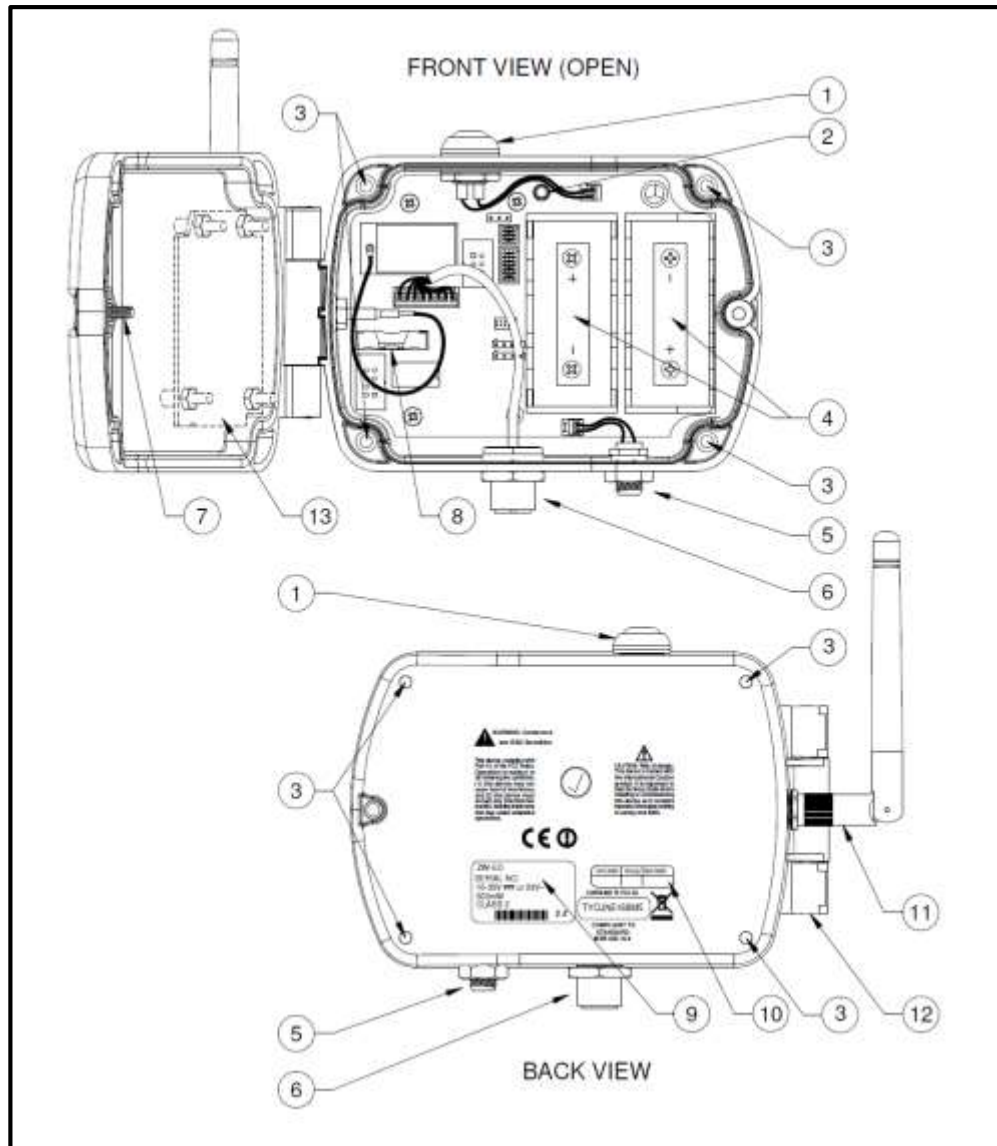

Figure 2.1 – ZW-ED Diagram

Table 2.1 – ZW-ED Diagram

1	Power Button	8	CR2032 Clock Backup Battery
2	Transmit LED	9	Serial Number
3	Mounting Holes (x4)	10	User Configuration Label
4	C Cell Battery Holders	11	2.4GHz Antenna
5	5 – 36VDC / 24VAC Power Connector	12	Hinge
6	M12 Digital Probe Connector	13	LCD (Optional)
7	Lid Screw		

2.2 DIP Switches

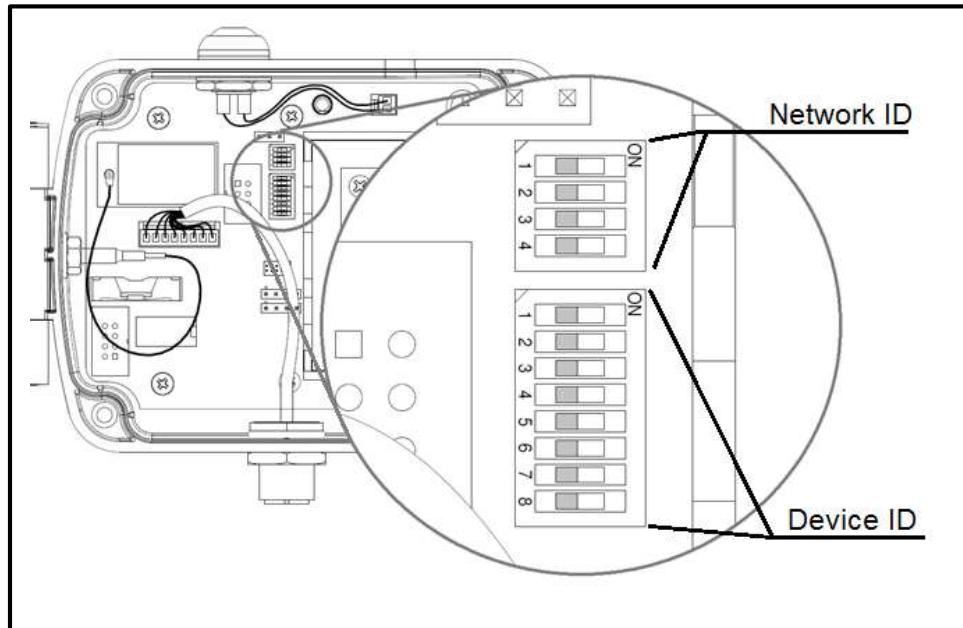

Figure 2.2 – ZW-ED DIP Switch Detail

The ZW-ED has two banks of DIP switched located near the battery holder, inside of the unit, for easy configuration. **Figure 2.2** shows a close up view of the switches. To change the DIP switches use a tweezer or small screwdriver to gently push the switch. Do not apply excessive force.

Setting the Network ID:

The set of 4 switches, labeled Network ID in **Figure 2.2**, set the Network ID. The Network ID (or NID) identifies which Receiver the ZW-ED will communicate with. If there are multiple Receivers deployed in the same area each one must have a unique NID. Make sure the same NID is selected on each of the End Devices you wish to monitor from a single Receiver. Record the NID in the Net Addr. field of the User Configuration Label for future reference. (See **Figure 2.1**.)

Table 2.2 – Network ID

Switch				NID	PID
8	7	6	5		
OFF	OFF	OFF	OFF	0	13106
OFF	OFF	OFF	ON	1	13107
OFF	OFF	ON	OFF	2	13108
OFF	OFF	ON	ON	3	13109
OFF	ON	OFF	OFF	4	13110
OFF	ON	OFF	ON	5	13111
OFF	ON	ON	OFF	6	13112
OFF	ON	ON	ON	7	13113

Switch				NID	PID
8	7	6	5		
OFF	OFF	OFF	OFF	8	13114
ON	OFF	OFF	ON	9	13115
ON	OFF	ON	OFF	10	13116
ON	OFF	ON	ON	11	13117
ON	ON	OFF	OFF	12	13118
ON	ON	OFF	ON	13	13119
ON	ON	ON	OFF	14	13120
ON	ON	ON	ON	15	13121



Caution: The NID may be set with a different set of switches on your Receiver. Please refer to your Receiver user manual to determine which switches correspond to the NID.

Setting the Device ID:

The set of 8 switches, labeled Device ID in **Figure 2.2**, set the Device ID. The Device ID (or DID) uniquely identifies each ZW-ED to its Receiver. If there are multiple End Devices connected to a Receiver each one must have a unique DID. The ZW-ED supports Device IDs 0 to 127. Refer to **Table 2.3** and **Table 2.4** for the correct switch settings for each DID. Record the DID in the Unit Addr. field of the User Configuration Label for future reference. (See **Figure 2.1**.)

Table 2.3 – Device ID (0 – 63)

Switch							DID
7	6	5	4	3	2	1	
OFF	OFF	OFF	OFF	OFF	OFF	OFF	0
OFF	OFF	OFF	OFF	OFF	OFF	ON	1
OFF	OFF	OFF	OFF	OFF	ON	OFF	2
OFF	OFF	OFF	OFF	OFF	ON	ON	3
OFF	OFF	OFF	OFF	ON	OFF	OFF	4
OFF	OFF	OFF	OFF	ON	OFF	ON	5
OFF	OFF	OFF	OFF	ON	ON	OFF	6
OFF	OFF	OFF	OFF	ON	ON	ON	7
OFF	OFF	OFF	ON	OFF	OFF	OFF	8
OFF	OFF	OFF	ON	OFF	OFF	ON	9
OFF	OFF	OFF	ON	OFF	ON	OFF	10
OFF	OFF	OFF	ON	OFF	ON	ON	11
OFF	OFF	OFF	ON	ON	OFF	OFF	12
OFF	OFF	OFF	ON	ON	OFF	ON	13
OFF	OFF	OFF	ON	ON	ON	OFF	14
OFF	OFF	OFF	ON	ON	ON	ON	15
OFF	OFF	ON	OFF	OFF	OFF	OFF	16
OFF	OFF	ON	OFF	OFF	OFF	ON	17
OFF	OFF	ON	OFF	OFF	ON	OFF	18
OFF	OFF	ON	OFF	OFF	ON	ON	19
OFF	OFF	ON	OFF	ON	OFF	OFF	20
OFF	OFF	ON	OFF	ON	OFF	ON	21
OFF	OFF	ON	OFF	ON	ON	OFF	22
OFF	OFF	ON	OFF	ON	ON	ON	23
OFF	OFF	ON	ON	OFF	OFF	OFF	24
OFF	OFF	ON	ON	OFF	OFF	ON	25
OFF	OFF	ON	ON	OFF	ON	OFF	26
OFF	OFF	ON	ON	OFF	ON	ON	27
OFF	OFF	ON	ON	ON	OFF	OFF	28
OFF	OFF	ON	ON	ON	OFF	ON	29
OFF	OFF	ON	ON	ON	ON	OFF	30
OFF	OFF	ON	ON	ON	ON	ON	31

Switch							DID
7	6	5	4	3	2	1	
OFF	ON	OFF	OFF	OFF	OFF	OFF	32
OFF	ON	OFF	OFF	OFF	OFF	ON	33
OFF	ON	OFF	OFF	OFF	ON	OFF	34
OFF	ON	OFF	OFF	OFF	ON	ON	35
OFF	ON	OFF	OFF	ON	OFF	OFF	36
OFF	ON	OFF	OFF	ON	OFF	ON	37
OFF	ON	OFF	OFF	ON	ON	OFF	38
OFF	ON	OFF	OFF	ON	ON	ON	39
OFF	ON	OFF	ON	OFF	OFF	OFF	40
OFF	ON	OFF	ON	OFF	OFF	ON	41
OFF	ON	OFF	ON	OFF	ON	OFF	42
OFF	ON	OFF	ON	OFF	ON	ON	43
OFF	ON	OFF	ON	ON	OFF	OFF	44
OFF	ON	OFF	ON	ON	OFF	ON	45
OFF	ON	OFF	ON	ON	ON	OFF	46
OFF	ON	OFF	ON	ON	ON	ON	47
OFF	ON	ON	OFF	OFF	OFF	OFF	48
OFF	ON	ON	OFF	OFF	OFF	ON	49
OFF	ON	ON	OFF	OFF	ON	OFF	50
OFF	ON	ON	OFF	OFF	ON	ON	51
OFF	ON	ON	OFF	ON	OFF	OFF	52
OFF	ON	ON	OFF	ON	OFF	ON	53
OFF	ON	ON	OFF	ON	ON	OFF	54
OFF	ON	ON	OFF	ON	ON	ON	55
OFF	ON	ON	ON	OFF	OFF	OFF	56
OFF	ON	ON	ON	OFF	OFF	ON	57
OFF	ON	ON	ON	OFF	ON	OFF	58
OFF	ON	ON	ON	OFF	ON	ON	59
OFF	ON	ON	ON	ON	OFF	OFF	60
OFF	ON	ON	ON	ON	OFF	ON	61
OFF	ON	ON	ON	ON	ON	OFF	62
OFF	ON	ON	ON	ON	ON	ON	63

Table 2.4 – Device ID (64 - 127)

Switch							DID
7	6	5	4	3	2	1	
ON	OFF	OFF	OFF	OFF	OFF	OFF	64
ON	OFF	OFF	OFF	OFF	OFF	ON	65
ON	OFF	OFF	OFF	OFF	ON	OFF	66
ON	OFF	OFF	OFF	OFF	ON	ON	67
ON	OFF	OFF	OFF	ON	OFF	OFF	68
ON	OFF	OFF	OFF	ON	OFF	ON	69
ON	OFF	OFF	OFF	ON	ON	OFF	70
ON	OFF	OFF	OFF	ON	ON	ON	71
ON	OFF	OFF	ON	OFF	OFF	OFF	72
ON	OFF	OFF	ON	OFF	OFF	ON	73
ON	OFF	OFF	ON	OFF	ON	OFF	74
ON	OFF	OFF	ON	OFF	ON	ON	75
ON	OFF	OFF	ON	ON	OFF	OFF	76
ON	OFF	OFF	ON	ON	OFF	ON	77
ON	OFF	OFF	ON	ON	ON	OFF	78
ON	OFF	OFF	ON	ON	ON	ON	79
ON	OFF	ON	OFF	OFF	OFF	OFF	80
ON	OFF	ON	OFF	OFF	OFF	ON	81
ON	OFF	ON	OFF	OFF	ON	OFF	82
ON	OFF	ON	OFF	OFF	ON	ON	83
ON	OFF	ON	OFF	ON	OFF	OFF	84
ON	OFF	ON	OFF	ON	OFF	ON	85
ON	OFF	ON	OFF	ON	ON	OFF	86
ON	OFF	ON	OFF	ON	ON	ON	87
ON	OFF	ON	ON	OFF	OFF	OFF	88
ON	OFF	ON	ON	OFF	OFF	ON	89
ON	OFF	ON	ON	OFF	ON	OFF	90
ON	OFF	ON	ON	OFF	ON	ON	91
ON	OFF	ON	ON	ON	OFF	OFF	92
ON	OFF	ON	ON	ON	OFF	ON	93
ON	OFF	ON	ON	ON	ON	OFF	94
ON	OFF	ON	ON	ON	ON	ON	95

Switch							DID
7	6	5	4	3	2	1	
ON	ON	OFF	OFF	OFF	OFF	OFF	96
ON	ON	OFF	OFF	OFF	OFF	ON	97
ON	ON	OFF	OFF	OFF	ON	OFF	98
ON	ON	OFF	OFF	OFF	ON	ON	99
ON	ON	OFF	OFF	ON	OFF	OFF	100
ON	ON	OFF	OFF	ON	OFF	ON	101
ON	ON	OFF	OFF	ON	ON	OFF	102
ON	ON	OFF	OFF	ON	ON	ON	103
ON	ON	OFF	ON	OFF	OFF	OFF	104
ON	ON	OFF	ON	OFF	OFF	ON	105
ON	ON	OFF	ON	OFF	ON	OFF	106
ON	ON	OFF	ON	OFF	ON	ON	107
ON	ON	OFF	ON	ON	OFF	OFF	108
ON	ON	OFF	ON	ON	OFF	ON	109
ON	ON	OFF	ON	ON	ON	OFF	110
ON	ON	OFF	ON	ON	ON	ON	111
ON	ON	ON	OFF	OFF	OFF	OFF	112
ON	ON	ON	OFF	OFF	OFF	ON	113
ON	ON	ON	OFF	OFF	ON	OFF	114
ON	ON	ON	OFF	OFF	ON	ON	115
ON	ON	ON	OFF	ON	OFF	OFF	116
ON	ON	ON	OFF	ON	OFF	ON	117
ON	ON	ON	OFF	ON	ON	OFF	118
ON	ON	ON	OFF	ON	ON	ON	119
ON	ON	ON	ON	OFF	OFF	OFF	120
ON	ON	ON	ON	OFF	OFF	ON	121
ON	ON	ON	ON	OFF	ON	OFF	122
ON	ON	ON	ON	OFF	ON	ON	123
ON	ON	ON	ON	ON	OFF	OFF	124
ON	ON	ON	ON	ON	OFF	ON	125
ON	ON	ON	ON	ON	ON	OFF	126
ON	ON	ON	ON	ON	ON	ON	127

2.3 Power Button

The Power Button is located on the top of the ZW-ED. (See **Figure 2.1.**) It allows for rebooting and shutting down the ZW-ED. You may need to reboot the ZW-ED to have it rejoin the network, if your Network ID, Device ID, Receiver, or Probe has changed, or if a different RF Frequency is selected. To reset the ZW-ED, quickly press the power button. When released the ZW-ED remunerates. The unit updates the Network ID and Device ID, detects connected sensors, and searched for a Receiver.

Holding the reset switch for longer than 3 seconds will turn off the ZW-ED. When holding the reset switch the blue LED turns on. When the blue LED turns off release the switch and the unit will be powered off. Pressing the switch again will turn the unit back on. Remove the Alkaline Batteries before long term storage of the ZW-ED.

2.4 Dimensions and Mounting

The ZW-ED includes all required hardware for mounting. To mount the ZW-ED, position unit where required. Mark the location of the top center of the unit. Refer to **Figure 2.3** to mark and drill four pilot holes as indicated. Use the included drywall anchors if needed. Open the lid of the ZW-ED to access the mounting points. Use the included screws to secure the ZW-ED.

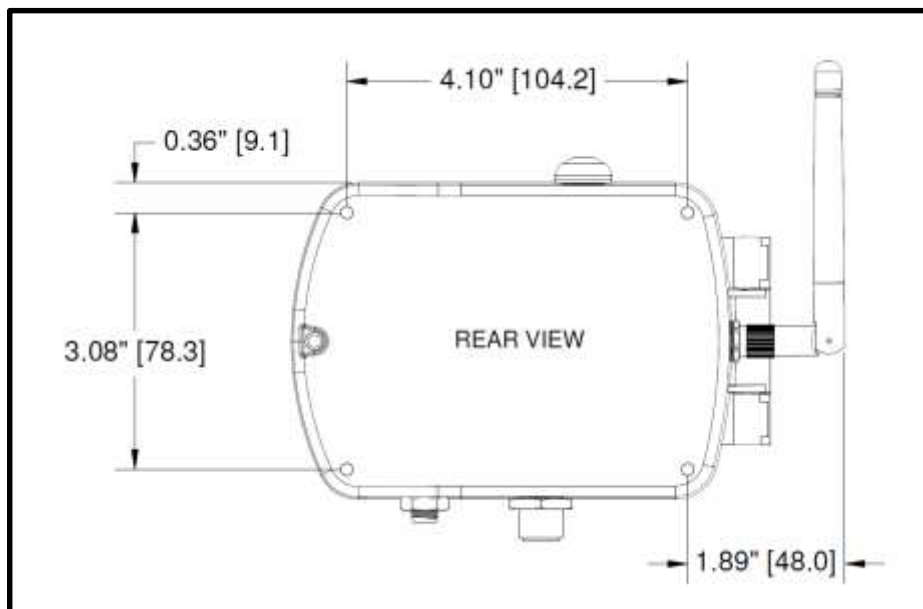

Figure 2.3 – Mounting Dimensions

- When mounting the unit be sure to leave room on the top to access the Power button and on the bottom and side for the Probe and Antenna.
- Mount the unit away from any large metal obstructions such as posts, catwalks, or large machinery.
- For best wireless range do not co-locate the ZW-ED with other 2.4GHz wireless equipment such as wireless routers or access points.
- For best wireless range elevate the ZW-ED and keep a direct line of sight the Receiver.

PART 3: Initial Setup

This section guides you through the setup of your ZW-ED. Please do not power on the unit until instructed. Ensure your Receiver is set up before setting up your ZW-ED. You will need to know the Network ID of your Receiver before the ZW-ED can be set up. If you power on your ZW-ED before your receiver is setup and running, you may need to reset it to join the network.

3.1 Antenna Warning

Before powering up the ZW-ED ensure the supplied antenna is properly installed. Running the ZW-ED without an antenna, or with an unapproved antenna, may cause damage to the device and/or cause operation outside of regulatory compliance. Omega Engineering accepts no liability and issues no warranty for devices operated improperly.

3.2 Choosing a Wireless Network ID

The Wireless Network ID (NID) selects which Receiver the ZW-ED communicates with. Selected the NID using the 4 DIP switches found inside the unit next to the battery holder. See **Section 2.2** for detailed instructions. If you are adding an End Device into an existing wireless sensor installation, first determine which Network ID your existing Receiver is using and use the same settings. Use **Table 2.2** to determine the correct DIP switch settings for the ZW-ED.

If this is a new installation with only one Receiver it is recommended to use the default NID of 0. All ZW-EDs ship with a default NID of 0. If this installation requires multiple Receivers ensure that each Receiver has a unique NID.

 Record the NID in the Net. Addr. field of User Configuration Label for easy reference in the future.

3.3 Choosing a Device ID

The Device ID (DID) uniquely identifies your ZW-ED on your wireless network. No two End Devices on your network may have the same Device ID and Network ID. Your ZW-ED comes preconfigured to use DID 0. If this is a new network it is suggested you start assigning your Device IDs sequentially. If this ZW-ED will be added to a current deployment be sure to check for existing DIDs before assigning a new one. Use Table 2.3 to determine the correct DIP switch settings.

 Record the DID in the Unit Addr. field of User Configuration Label for easy reference in the future.

 For large deployments it is recommended that you keep a list of Device IDs and Network IDs currently deployed to ensure devices are not misconfigured.

3.4 Connecting your Sensors

The ZW-ED works with a wide variety of sensors. Most sensors come packaged in a probe and each probe is suited to different applications. Some probes may contain multiple sensors. The ZW-ED automatically detects connected sensors on power up and transmits that data to the Receiver. No additional configuration is required. **Table 3.1** provides a partial list of supported digital probes. These digital probes may be directly connected to the M12 Digital Probe Connector. (See **Figure 2.1.**) An extension cable may be used with digital probes if desired.

Table 3.1 – Compatible Probes

Probe	Sensor Type	Smart Sensor	Description
zTP1-P	T	No	Stick probe with 10' Cable
zTP2-P	T	No	Lug Mount probe with 10' Cable
zTHP-P	T, H	No	6" Industrial Probe with 10' Cable Temperature / Humidity
zTHP2-P	T, H	No	3" Industrial Probe Temperature / Humidity
zBTHP-P	T, H, B	No	6" Industrial Probe with 10' Cable Temperature / Humidity / Barometric Pressure
zBTP-P	T, B	No	6" Industrial Probe with 10' Cable Temperature Barometric Pressure
BTH-SP-X-Y	T, H, B	Yes	3" Industrial Probe Temperature / Humidity / Barometric Pressure Order Options: X # Desired Simultaneous Readings Y -- Standard 3" Probe BH Bulk Head Mount Probe
BTHL-SP-X	T, H, B, L	Yes	3" Industrial Probe Temperature / Humidity / Barometric Pressure / Light Order Options: X # Desired Simultaneous Readings

Probe Installation

To install or change a probe, first power down the ZW-ED by holding the Power Button for 3 seconds. See **Section 2.3** for more details. To remove a probe, grasp the metal knurl only and turn it in a counter clockwise direction. DO not rotate the probe body.

When installing a new probe or cable take note of the alignment key in the connector. Align this key with the keyway in the mating connector on the ZW-ED. The keyway is located closest to the cover of the ZW-ED. See **Figure 3.1** for more details. Turn the metal knurl of the probe in a clockwise direction while leaving the probe body stationary. Ensure that the probe is inserted to the base of the knurl to maintain a NEMA 4¹ rating on the ZW-ED.

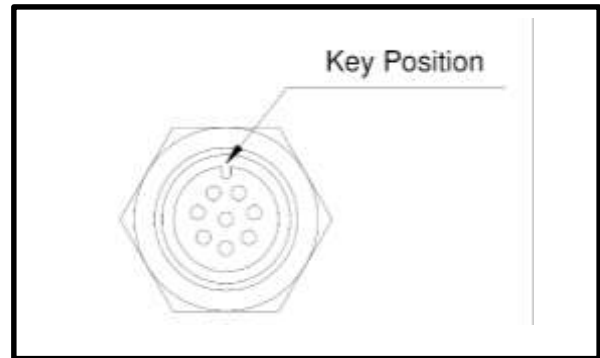

Figure 3.1 – Digital Probe Connector



Caution: Do not rotate the body of the probe or cable. Do not use pliers, vice grips or other tools on probes. Hand tighten only.

¹ Probes many not be NEMA 4 rated. NEMA 4 Rating applies only to ZW-ED.

3.5 Powering the Unit

Once the NID and DID are set and the Antenna and Probe are installed the ZW-ED may be powered on.

The ZW-ED is powered using low cost Alkaline C cell batteries, the external M8 connector or both. The ZW-ED automatically switches from the internal batteries to the external power if available. If the external power is removed, the ZW-ED switches back to the internal batteries.

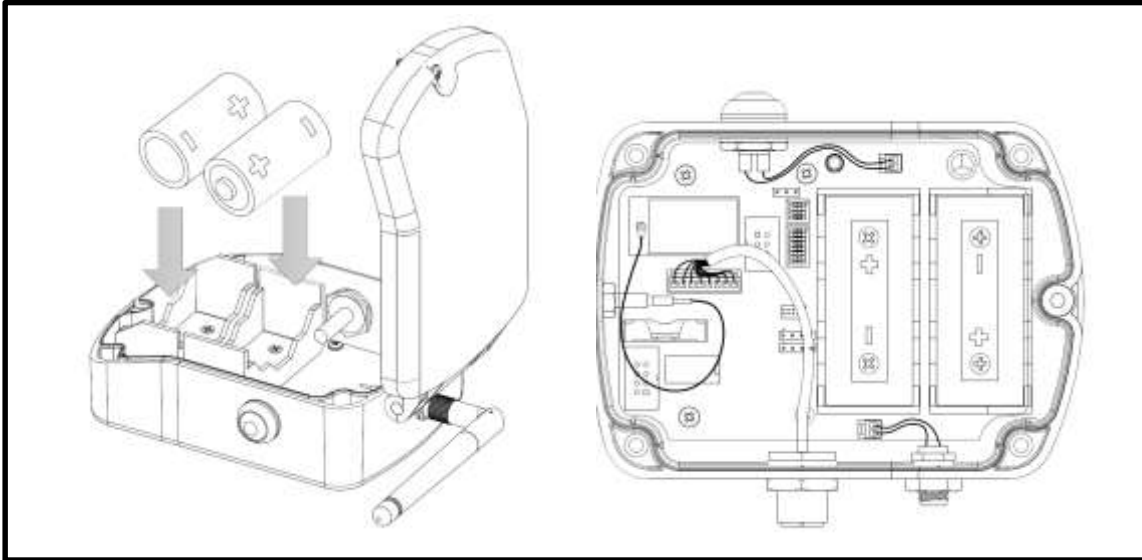



Figure 3.2 – Battery Installation

Batteries

To install the batteries, open the ZW-ED and unscrew the lid screw using a Philips head screwdriver. The battery orientation is marked on the battery holders and is shown in **Figure 3.2**. Install the supplied Alkaline C Cell batteries as indicated.

To remove the batteries, insert a screw driver under the battery and gently loosen it. Remove the battery on the right first to make room to remove the remaining battery.

 **Caution:** Use only 1.5V alkaline batteries in the ZW-ED. Other battery chemistries may damage your ZW-ED or lead to reduced battery life.

Coin Cell

The ZW-ED comes with a CR2032 Lithium Coin cell battery pre-installed. This battery keeps the real time clock for the ZW-ED running even when the unit is not powered and has an expected life time of more than 10 years under room temperature conditions. If it needs to be replaced, carefully remove the battery from the holder.

 **Caution:** Do not use conductive pliers or other grasping tools that may short the battery terminals.

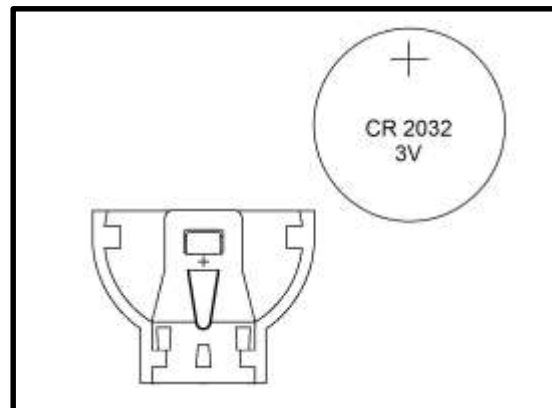

Figure 3.3 – Coin Cell Holder

Insert a new battery taking note of the proper orientation as shown in **Figure 3.3**. The positive battery terminal contacts the large terminal and faces towards the top of the ZW-ED.

Line Power

The ZW-ED may also be powered using line power. The Power Connector can accept $5V_{DC}$ to $36V_{DC}$ and $24V_{AC}$. An optional Safety Qualified AC adaptor¹ is available to simplify installation. If you are supplying your own power for the ZW-ED, a M8 Field Installable Connector is available. A soldering iron is required to use the M8 Field Connector. Refer to **Figure 3.4** for the correct wiring for the ZW-ED.

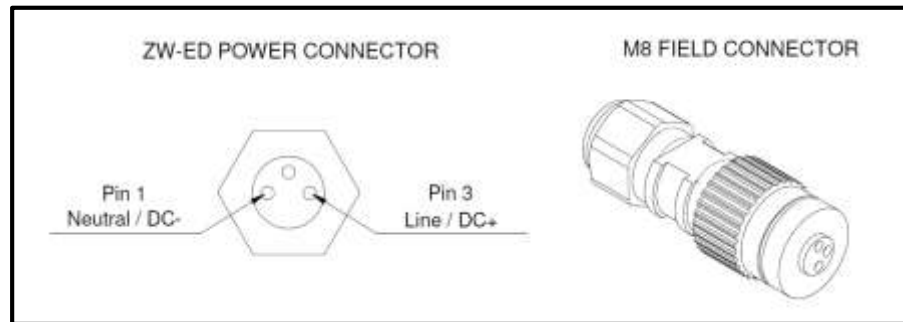

Figure 3.4- Power Connector

To install an external power connector, first remove the dust cap on the ZW-ED Power Connector. Align the sockets in the connector with the pins on the ZW-ED. Insert the connector and rotate the metal knurl clockwise while holding the connector body steady. Ensure the connector is tight. The connector should be firmly mated to maintain NEMA 4 ingress protection. Some exposed threads are normal when the connector is mated.



Caution: Do not rotate the body connector. Do not use pliers, vice grips or other tools. Hand tighten only.

3.6 Start Up and Enumeration

The ZW-ED starts automatically when power is applied. On power up, the ZW-ED reads the Network ID and Device ID, detects any connected sensors, and establishes a link to the Receiver. The blue link indicator LED flashes while the ZW-ED searches for a Receiver. Once communications is established, the LED will flash quickly and turn off. The LED will flash again each time a new reading is transmitted.

If the LED does not stop blinking it indicates the ZW-ED cannot establish a connection to the Receiver. Check that the Receiver is on and configured correctly. Check that the Network ID on both the ZW-ED and the Receiver are the same. After making any changes, press the Power Button on the top of the unit to reset the ZW-ED and force it to rescan for the Receiver.

Once a link has been established, close the lid of the ZW-ED and tighten the lid screw. To maintain a NEMA 4 rating, make sure the lid is flush with the body and does not show any gaps. The ZW-ED is now ready for use. Refer to your Receiver user manual for instruction on how to view readings, change the measurement frequency and log data.

¹ Optional AC adaptor is not NEMA 4 rated.

PART 4: SPECIFICATIONS

4.1 Wireless Communications

Standard: IEEE 802.15.4, DSSS

Frequency: 2.4 GHz (2400 to 2483.5MHz), 16 channels

Network Topology: Star topology

Transmit Power: 9.5dBm

Receiver Sensitivity: -96dBm

Range: Up to 1000 m (3280')¹

4.2 Power

Input Power:

Input Voltage: 5 to 36 V_{DC}, 24V_{AC} +/- 10%

Input Power: 0.8 W maximum

Batteries (Included):

2x C-Cell Alkaline

1x CR2032 Coin Cell (RTC Backup Only)

Safety Qualified AC Power Adaptor (Optional):

Nominal Output: 5 V_{DC}, @ 0.6 A

Input: 100 to 240 V_{AC}, 50/60 Hz

Operating Temperature: 0 to 40°C (32 to 104°F)

4.3 Environmental

-18 to 55°C (0 to 130°F)

90% RH non-condensing

NEMA 4

4.4 General

Agency Approvals: ECCN 5A992, EMC 2014/30/EU

LVD 2014/35/EU, RED 2014/53/EU

Software: Compatible with the OMEGA® Dashboard

4.5 Battery Life

Update Time	Estimated Battery Life
10 Seconds	2.5 Years
30 Seconds	5 Years
>60 Seconds	Up to 7 Years

4.6 Power Connector (Optional)

Operating Temperature: -25 to 90°C (-13 to 194°F)

Allowable Cable Diameter: 3.5mm to 5.0mm

Sealing: IP 67 when mated

¹ Without obstructions or interference.

APPENDIX A: RF Topics

This section discusses some topics to ensure the best RF coverage range.

RF Channel Selection

The 802.15.4 wireless standard uses 16 RF channels numbered 11 through 26. Each channel has a bandwidth of 2MHz and channels are separated by 5MHz. When a ZW-ED is powered on it automatically searches for a Receiver with the same Network ID by scanning each RF channel. The Receiver dictates the RF channel the ZW-ED will use. You may choose to manually select your RF Channel at the Receiver. See your Receiver User Manual for more information.

You may want to manually select an RF channel if you are running multiple receivers in one area. While multiple Receivers can coexist on the same RF channel, selecting different channels is recommended. Using separate RF channels will reduce potential interference between systems. This is particularly true for large deployments.

Wi-Fi networks may also create interference with the ZW-ED. Wi-Fi networks operate on fixed frequencies with channels occupying 20MHz or 40MHz of bandwidth. While there are many Wi-Fi Channels there are only a few non-overlapping channels that are generally used. Figure A.1 shows the 802.15.4 channels mapped against the occupied bandwidth of the most commonly used Wi-Fi Channels in North America and Europe. If you know what WiFi channels are currently in use, select an 802.15.4 channel that does not overlap with it to reduce interference.

Frequency		2405	2410	2415	2420	2425	2430	2435	2440	2445	2450	2455	2460	2465	2470	2475	2480	2485	2490
802.15.4		CH 11	CH 12	CH 13	CH 14	CH 15	CH 16	CH 17	CH 18	CH 19	CH 20	CH 21	CH 22	CH 23	CH 24	CH 25	CH 26		
USA & Canada	802.11b/g/n	CH 1				CH 6				CH 11									
	802.11n (Bonded)	CH 3 (1+5)																	
Most Other Countries	802.11b	CH 1				CH 6				CH 11				CH 14 (Japan Only)					
	802.11g/n	CH 1				CH 5				CH 9				CH 13					
	802.11n (Bonded)	CH 3 (1+5)								CH 11 (9+13)									

Figure A.1 – Global Frequency Chart

Signal Strength Indicator

When the ZW-ED transmits, it reports its Received Signal Strength to the Receiver. This reading can be viewed on your Receiver and indicates how well the ZW-ED can hear the Receiver. The received signal strength is important because each transmission sent by the ZW-ED must be confirmed by the Receiver. If the ZW-ED does not receive a confirmation it will retry sending the data until successful.

The ZW-ED has a receive sensitivity of -96dBm or better. It is recommended that the received signal be at least -86dBm on average to maintain reliable communications. In most cases this means that the Signal Strength reading should be 15% to 20%.

Figure A.2 shows the rough mapping from Received Power to Signal Strength. Receive power is measured in dBm which is a logarithmic term. For every 10dBm increase in receive power the actual power is increased by 10 times.



If the wireless link is weak the ZW-ED will need to re-transmit often which lowers its battery life. Use the Diagnostic page on your Receiver to view the Signal Strength of the ZW-ED and reposition it if necessary.

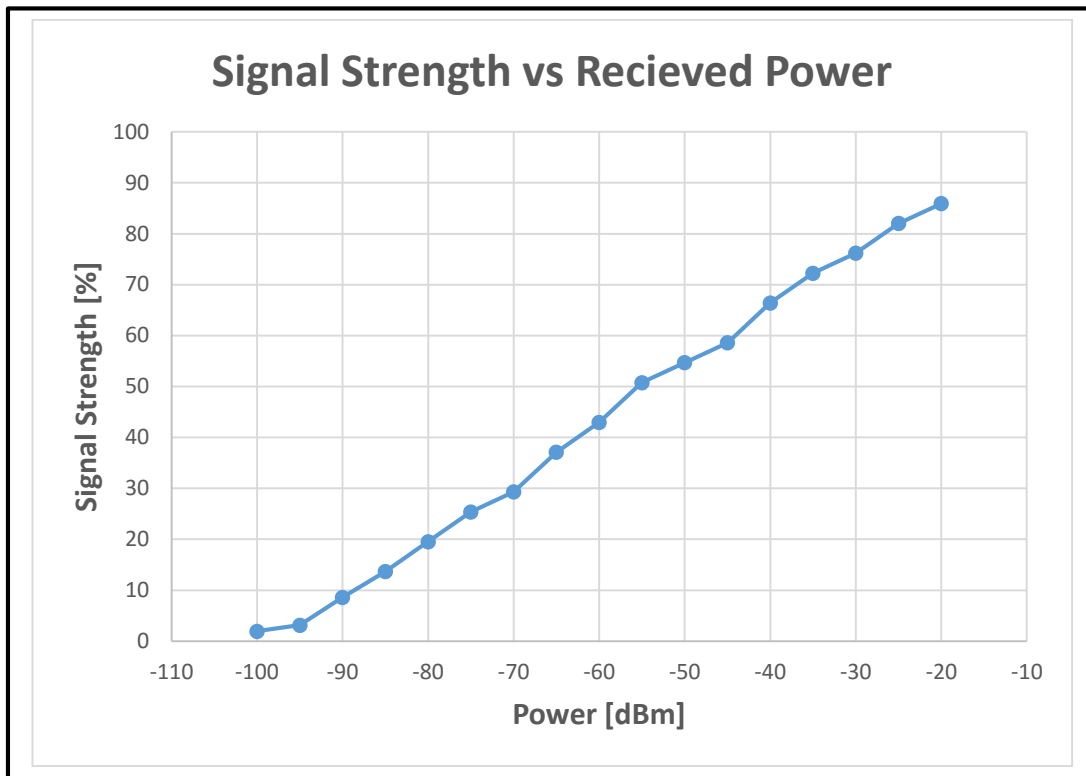

Figure A.2 – Received Power Chart

Maximizing Range

Under favorable conditions the ZW-ED can achieve a, line of sight, wireless link distance of up to 1000m. Generally most indoor applications will not be able to achieve these distances, although steps can be taken to maximize range. Ensure the Receiver and End Device are located away from large obstacles and other RF sources such as Wireless Access points and microwaves. Keep objects clear of the zone between the End Device and Receiver. Metal objects, walls, and cubical partitions in particular will all significantly reduce the signal strength.

The antenna provided with the ZW-ED is a dipole. Care must be taken in the positioning of the antenna to achieve the best possible range. The gain of the antenna is lower along the axis of the antenna. Do not point the ZW-ED antenna in the direction of the Receiver. When possible, the ZW-ED antenna should be parallel to the Receiver antenna.

Keep the antenna away from dense or metallic structures. Metallic structures should be kept away by at least 0.8" (2 cm), although 2.4" (6 cm) is recommended. Objects too close to the antenna may screen the ZW-ED from the Receiver. Reflections off of nearby objects can also cause destructive interference reducing received signal strength.

For long distance connections the ZW-ED and the Receiver should be elevated to keep the signal from being attenuated by the ground. Elevate each device by at least 0.6 meters above the ground for each 100 meters or separation. It is best to keep this same clearance distance to walls, ceilings and other obstructions as well.

APPENDIX B: Wireless Certifications

Federal Communication Commission Interference Statement



In order to comply with FCC radio frequencies (RF) exposure limits, dipole antennas should be located at a minimum 7.9" (200mm) or more from the body of all persons.

This device complies with Part 15 of the FCC Rules. Operation is subject to the following two conditions: (1) This device may not cause harmful interference, and (2) this device must accept any interference received, including interference that may cause undesired operation.

This equipment has been tested and found to comply with the limits of a Class B digital device, pursuant to Part 15 of the FCC Rules. These limits are designed to provide reasonable protection against harmful interference when the equipment is operated in a residential environment. This equipment generates, uses, and radiates radio frequency energy, and if not installed and used in accordance with the instructions, may cause harmful interference. However, there is no guarantee that interference will not occur. If this equipment does cause interference to radio or television reception, which can be determined by turning the equipment off and on, the user is encouraged to correct the interference by one of the following measures:

- Reorient or relocate the receiving antenna.
- Increase separation between the equipment and receiver.
- Connect the equipment to an outlet on a circuit different from which the receiver is connected.
- Consult dealer or an experienced radio/TV technician.

Industry Canada Statement

<p>This device complies with Industry Canada license-exempt RSS standard(s). Operation is subject to the following two conditions: (1) this device may not cause interference, and (2) this device must accept any interference, including interference that may cause undesired operation of the device.</p>	<p>Le présent appareil est conforme aux CNR d'Industrie Canada applicables aux appareils radio exempts de licence. L'exploitation est autorisée aux deux conditions suivantes : (1) l'appareil ne doit pas produire de brouillage, et (2) l'utilisateur de l'appareil doit accepter tout brouillage radioélectrique subi, même si le brouillage est susceptible d'en compromettre le fonctionnement</p>
---	---

This device have been designed to operate with antennas having a maximum gain of 2.2 dBi. Antennas having a gain greater than 2.2 dBi are strictly prohibited for use with this device. The required antenna impedance is 50 ohms.

CE Statement



The following alert sign indicates that there are restrictions on usage of the equipment in regards to power limitations on Equivalent Isotropic Radiated Power (EIRP) levels in the European Community.

The Following Are user Restrictions:

- Combinations of power levels and antennas resulting in a radiated power level above 10 mW - EIRP for Direct Sequence Spectrum (DSSS) devices are considered as not compliant, and are not allowed for use within the European Community and other countries that have adopted the European R&TTE directive 2014/53/EU or the CEPT recommendation ERC/REC 70-03 or both.
- This device have been designed to operate with antennas having a maximum gain of 2.2 dBi. Antennas having a gain greater than 2.2 dBi are strictly prohibited for use with this device. The required antenna impedance is 50 ohms.

APPENDIX C: SAFETY & REGULATORY COMPLIANCE

Safety:

EN 61010-1 3rd Edition

EMC:

EN 61326-1:2013

Radio:

EN 300 328 V1.8.1:2012-04

CE:

The product herewith complies with the essential requirements and other relevant provisions of the Radio Equipment Directive 2014/53/EU, the EMC Directive 2014/30/EU, and the Low Voltage Directive 2014/35/EU, and carries the CE-marking accordingly.

The following CE Mark  is affixed to this equipment.

The CE declaration is available at the website listed on the cover page of this manual.

FCC / IC:

Part 15C, Class DTS Intentional radiator

Contains TX FCC ID: TYOJN5168M5

Contains Industry Canada ID IC: 7438A-CYO5168M5

FCC Radiation Exposure Statement:

This portable equipment with its antenna complies with FCC's RF radiation exposure limits set forth for an uncontrolled environment. To maintain compliance follow the instructions below;

1. This transmitter must not be co-located or operating in conjunction with any other antenna or transmitter.
2. Avoid direct contact to the antenna, or keep it to a minimum while using this equipment.

Where Do I Find Everything I Need for Process Measurement and Control? **OMEGA...Of Course!** *Shop online at omega.comSM*

TEMPERATURE

- ☑ Thermocouple, RTD & Thermistor Probes, Connectors, Panels & Assemblies
- ☑ Wire: Thermocouple, RTD & Thermistor
- ☑ Calibrators & Ice Point References
- ☑ Recorders, Controllers & Process Monitors
- ☑ Infrared Pyrometers

PRESSURE, STRAIN AND FORCE

- ☑ Transducers & Strain Gages
- ☑ Load Cells & Pressure Gages
- ☑ Displacement Transducers
- ☑ Instrumentation & Accessories

FLOW/LEVEL

- ☑ Rotameters, Gas Mass Flowmeters & Flow Computers
- ☑ Air Velocity Indicators
- ☑ Turbine/Paddlewheel Systems
- ☑ Totalizers & Batch Controllers

pH/CONDUCTIVITY

- ☑ pH Electrodes, Testers & Accessories
- ☑ Benchtop/Laboratory Meters
- ☑ Controllers, Calibrators, Simulators & Pumps
- ☑ Industrial pH & Conductivity Equipment

DATA ACQUISITION

- ☑ Data Acquisition & Engineering Software
- ☑ Communications-Based Acquisition Systems
- ☑ Plug-in Cards for Apple, IBM & Compatibles
- ☑ Data Logging Systems
- ☑ Recorders, Printers & Plotters

HEATERS

- ☑ Heating Cable
- ☑ Cartridge & Strip Heaters
- ☑ Immersion & Band Heaters
- ☑ Flexible Heaters
- ☑ Laboratory Heaters

ENVIRONMENTAL MONITORING AND CONTROL

- ☑ Metering & Control Instrumentation
- ☑ Refractometers
- ☑ Pumps & Tubing
- ☑ Air, Soil & Water Monitors
- ☑ Industrial Water & Wastewater Treatment
- ☑ pH, Conductivity & Dissolved Oxygen Instruments

WARRANTY/DISCLAIMER

OMEGA ENGINEERING, INC. warrants this unit to be free of defects in materials and workmanship for a period of **25 months** from date of purchase. OMEGA's WARRANTY adds an additional one (1) month grace period to the normal **two (2) year product warranty** to cover handling and shipping time. This ensures that OMEGA's customers receive maximum coverage on each product.

If the unit malfunctions, it must be returned to the factory for evaluation. OMEGA's Customer Service Department will issue an Authorized Return (AR) number immediately upon phone or written request. Upon examination by OMEGA, if the unit is found to be defective, it will be repaired or replaced at no charge. OMEGA's WARRANTY does not apply to defects resulting from any action of the purchaser, including but not limited to mishandling, improper interfacing, operation outside of design limits, improper repair, or unauthorized modification. This WARRANTY is VOID if the unit shows evidence of having been tampered with or shows evidence of having been damaged as a result of excessive corrosion; or current, heat, moisture or vibration; improper specification; misapplication; misuse or other operating conditions outside of OMEGA's control. Components in which wear is not warranted, include but are not limited to contact points, fuses, and triacs.

OMEGA is pleased to offer suggestions on the use of its various products. However, OMEGA neither assumes responsibility for any omissions or errors nor assumes liability for any damages that result from the use of its products in accordance with information provided by OMEGA, either verbal or written. OMEGA warrants only that the parts manufactured by the company will be as specified and free of defects. OMEGA MAKES NO OTHER WARRANTIES OR REPRESENTATIONS OF ANY KIND WHATSOEVER, EXPRESSED OR IMPLIED, EXCEPT THAT OF TITLE, AND ALL IMPLIED WARRANTIES INCLUDING ANY WARRANTY OF MERCHANTABILITY AND FITNESS FOR A PARTICULAR PURPOSE ARE HEREBY DISCLAIMED. LIMITATION OF LIABILITY: The remedies of purchaser set forth herein are exclusive, and the total liability of OMEGA with respect to this order, whether based on contract, warranty, negligence, indemnification, strict liability or otherwise, shall not exceed the purchase price of the component upon which liability is based. In no event shall OMEGA be liable for consequential, incidental or special damages.

CONDITIONS: Equipment sold by OMEGA is not intended to be used, nor shall it be used: (1) as a "Basic Component" under 10 CFR 21 (NRC), used in or with any nuclear installation or activity; or (2) in medical applications or used on humans. Should any Product(s) be used in or with any nuclear installation or activity, medical application, used on humans, or misused in any way, OMEGA assumes no responsibility as set forth in our basic WARRANTY/DISCLAIMER language, and, additionally, purchaser will indemnify OMEGA and hold OMEGA harmless from any liability or damage whatsoever arising out of the use of the Product(s) in such a manner.

RETURN REQUESTS/INQUIRIES

Direct all warranty and repair requests/inquiries to the OMEGA Customer Service Department. BEFORE RETURNING ANY PRODUCT(S) TO OMEGA, PURCHASER MUST OBTAIN AN AUTHORIZED RETURN (AR) NUMBER FROM OMEGA'S CUSTOMER SERVICE DEPARTMENT (IN ORDER TO AVOID PROCESSING DELAYS). The assigned AR number should then be marked on the outside of the return package and on any correspondence.

The purchaser is responsible for shipping charges, freight, insurance and proper packaging to prevent breakage in transit.

FOR **WARRANTY** RETURNS, please have the following information available BEFORE contacting OMEGA:

1. Purchase Order number under which the product was PURCHASED,
2. Model and serial number of the product under warranty, and
3. Repair instructions and/or specific problems relative to the product.

FOR **NON-WARRANTY** REPAIRS, consult OMEGA for current repair charges. Have the following information available BEFORE contacting OMEGA:

1. Purchase Order number to cover the COST of the repair,
2. Model and serial number of the product, and
3. Repair instructions and/or specific problems relative to the product.

OMEGA's policy is to make running changes, not model changes, whenever an improvement is possible. This affords our customers the latest in technology and engineering.

OMEGA is a registered trademark of OMEGA ENGINEERING, INC.

© Copyright 2017 OMEGA ENGINEERING, INC. All rights reserved. This document may not be copied, photocopied, reproduced, translated, or reduced to any electronic medium or machine-readable form, in whole or in part, without the prior written consent of OMEGA ENGINEERING, INC.