

**1 YEAR**  
WARRANTY

CE FC

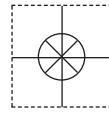

# Ω OMEGA® User's Guide



**Shop online at  
[omega.com](http://omega.com)®**

**e-mail: [info@omega.com](mailto:info@omega.com)  
For latest product manuals:  
[omegamanual.info](http://omegamanual.info)**

**ISO 9001**  
CERTIFIED  
CORPORATE QUALITY  
STAMFORD, CT

**ISO 9001**  
CERTIFIED  
CORPORATE QUALITY  
MANCHESTER, UK

## **UWIR-2A-NEMA and UWIR-2A-NEMA-HT Weather Resistant Non-Contact Infrared Temperature Sensor with Wireless Transmitter**



OMEGAnet® Online Service  
omega.com

Internet e-mail  
info@omega.com

### Servicing North America:

**U.S.A.:**  
ISO 9001 Certified

Omega Engineering, Inc., One Omega Drive, P.O. Box 4047  
Stamford, CT 06907-0047 USA

Toll Free: 1-800-826-6342

TEL: (203) 359-1660

FAX: (203) 359-7700

e-mail: info@omega.com

**Canada:**

976 Bergar

Laval (Quebec), H7L 5A1 Canada

Toll-Free: 1-800-826-6342

TEL: (514) 856-6928

FAX: (514) 856-6886

e-mail: info@omega.ca

### For immediate technical or application assistance:

**U.S.A. and Canada:** Sales Service: 1-800-826-6342/1-800-TC-OMEGA®  
Customer Service: 1-800-622-2378/1-800-622-BEST®  
Engineering Service: 1-800-872-9436/1-800-USA-WHEN®

**Mexico/  
Latin America:**

En Español: 001 (203) 359-7803

FAX: 001 (203) 359-7807

info@omega.com.mx

e-mail: espanol@omega.com

### Servicing Europe:

**Benelux:**

Managed by the United Kingdom Office

Toll-Free: 0800 099 3344

TEL: +31 20 347 21 21

FAX: +31 20 643 46 43

e-mail: sales@omegaeng.nl

**Czech Republic:**

Frystatska 184

733 01 Karviná, Czech Republic

Toll-Free: 0800-1-66342

TEL: +420-59-6311899

FAX: +420-59-6311114

e-mail: info@omegashop.cz

**France:**

Managed by the United Kingdom Office

Toll-Free: 0800 466 342

TEL: +33 (0) 161 37 29 00

FAX: +33 (0) 130 57 54 27

e-mail: sales@omega.fr

**Germany/ Austria:**

Daimlerstrasse 26

D-75392 Deckenpfronn, Germany

Toll-Free: 0800 6397678

TEL: +49 (0) 7056 9398-0

FAX: +49 (0) 7056 9398-29

e-mail: info@omega.de

**United Kingdom:**  
ISO 9001 Certified

OMEGA Engineering Ltd.

One Omega Drive, River Bend Technology Centre, Northbank

Irlam, Manchester M44 5BD United Kingdom

Toll-Free: 0800-488-488

TEL: +44 (0) 161 777-6611

FAX: +44 (0) 161 777-6622

e-mail: sales@omega.co.uk

---

It is the policy of OMEGA Engineering, Inc. to comply with all worldwide safety and EMC/EMI regulations that apply. OMEGA is constantly pursuing certification of its products to the European New Approach Directives. OMEGA will add the CE mark to every appropriate device upon certification.

The information contained in this document is believed to be correct, but OMEGA accepts no liability for any errors it contains, and reserves the right to alter specifications without notice.

**WARNING:** These products are not designed for use in, and should not be used for, human applications.



**Table of Contents**

<b>Section</b>	<b>Page</b>
<b>Section 1 Introduction</b> .....	<b>1-1</b>
1.1 Precautions .....	1-1
1.2 Safety Warnings and IEC Symbols .....	1-1
1.3 Product Labels .....	1-2
1.4 Statement on FCC and CE Marking .....	1-2
1.5 General Description and System Components .....	1-2
<b>Section 2 Hardware</b> .....	<b>2-1</b>
2.1 Package Inspection.....	2-1
2.2 Included Items .....	2-1
<b>Section 3 Operation</b> .....	<b>3-1</b>
3.1 Main Transmitter Board.....	3-1
3.2 Ambient Temperature .....	3-1
3.3 Atmospheric Quality .....	3-1
3.4 Optical Field of View .....	3-2
3.5 Adding Extension Cable.....	3-2
3.6 Sensor Head Accessories.....	3-2
<b>Section 4 Laser Sight Accessory</b> .....	<b>4-1</b>
4.1 Warning and Cautions .....	4-1
4.2 Operating the Laser Sight Accessory.....	4-1
<b>Section 5 Software</b> .....	<b>5-1</b>
5.1 Getting Started .....	5-1
5.2 Software Installation .....	5-1
<b>Section 6 End Device Operation</b> .....	<b>6-1</b>
6.1 Setup and Configuration.....	6-1
6.2 Mounting, Installation, Antenna and DIN Rail Mounting Bracket Installation .....	6-7
6.3 Battery Replacement .....	6-10
6.4 Input Connection .....	6-11
<b>Section 7 System Operation</b> .....	<b>7-1</b>
7.1 Introduction.....	7-1
7.2 RF Communication Basics .....	7-1
7.3 Basic System Overview .....	7-1
7.4 Environment/ Operating Conditions .....	7-2
7.5 Transmit Rate vs. Battery Life.....	7-3
<b>Section 8 Service and Calibration</b> .....	<b>8-1</b>
8.1 Service and Calibration .....	8-1
<b>Section 9 Specifications</b> .....	<b>9-1</b>
<b>Section 10 Emissivity Table</b> .....	<b>10-1</b>
<b>Section 11 Approvals, Regulatory Compliance</b> .....	<b>11-1</b>
11.1 FCC (Domestic Usage) .....	11-1
11.2 FCC (International Usage and CE Marking) .....	11-1

**List of Figures**

Section	Figure	Description .....	Page
<b>Section 1</b>	1-1	IEC Symbols .....	1-1
	1-2	Product Label Front View .....	1-2
	1-3	Product Label Rear View .....	1-2
	1-4	Transmitter With Connectors .....	1-2
<b>Section 3</b>	3-1	Main Transmitter Board .....	3-1
	3-2	Sensor Housing Dimensions .....	3-1
	3-3	Optical Field of View .....	3-2
	3-4	Sensor Head Mounting Bracket (OS100-MB) .....	3-2
	3-5	Water Cooling Jacket (OS100-WC) .....	3-3
	3-6	Water Cooling Jacket Installation .....	3-3
	3-7	Air Purge Collar (OS100-AP) .....	3-3
<b>Section 4</b>	4-1	Laser Sight Accessory (OS100-LS) .....	4-2
	4-2	Laser Warning Label .....	4-2
<b>Section 5</b>	5-1	Software - Welcome Screen .....	5-1
	5-2	Software - Select Installation Screen .....	5-2
	5-3	Software - Confirm Installation Screen .....	5-2
	5-4	Software – License Agreement Screen .....	5-3
	5-5	Software – Installation Complete Screen .....	5-3
<b>Section 6</b>	6-1	USB Cable .....	6-1
	6-2	Main Transmitter Board .....	6-3
	6-3	Launch Setup Utility .....	6-3
	6-4	Utility Program - Welcome Screen .....	6-4
	6-5	Utility Program – Connect To Transmitter Screen ..	6-4
	6-6	Utility Program – Setup Transmitter Screen .....	6-5
	6-7	Utility Program – Establish Link Screen .....	6-5
	6-8	Utility Program – Choose Options Screen .....	6-6
	6-9	Utility Program – Send Setting To Transmitter Screen .....	6-6
	6-10	Mounting .....	6-7
	6-11	Fresnel Zone .....	6-7
	6-12	DIN Rail Mounting Bracket Installation .....	6-9
	6-13	Battery Replacement .....	6-10
	6-14	Input Diagram for 5 Pin Connector .....	6-11
<b>Section 7</b>	7-1	End Device/Receiver .....	7-1

## Section 1 - Introduction

Please read this manual completely before installing and operating your wireless end device and receiver system. It's important to read and follow all notes, cautions, warnings and safety precautions before operating this end device. "End device" refers to your transmitter or receiver unit.

### 1.1 Precautions

- This device is not designed for use in any medical or nuclear applications.
- Do not operate this device in flammable or explosive environments.
- Never operate with a power source other than the one recommended in this manual.
- Do not operate this device outside of the recommended use outlined in this manual.
- No co-location with other radio transmitters is allowed. By definition, co-location is when another radio device or its antenna is located within 20 cm of your end device and can transmit simultaneously with your UWRTD unit.
- Never install wireless end devices within 20 cm or less from each other.
- Never install and/or operate your UWRTD unit closer than 20 cm to nearby persons.
- Never use your UWRTD unit as a portable device. Your unit has been designed to be operated in a permanent installation only.

#### NOTE:

There are no user serviceable parts inside your device. Attempting to repair or service your unit may void your warranty.

### 1.2 Safety Warnings and IEC Symbols

This device is marked with international safety and hazard symbols in accordance with IEC standards. It is important to read and follow all precautions and instructions in this manual before operating or commissioning this device as it contains important information relating to safety and EMC. Failure to follow all safety precautions may result in injury and or damage to your device. Use of this device in a manner not specified will void your warranty



IEC symbols	Description
	Caution, refer to accompanying documentation
	EU's Waste Electrical and Electronic Equipment Compliance

Figure 1-1. IEC Symbols

## 1.3 Product Labeling

### 1.3.1 Product Labeling

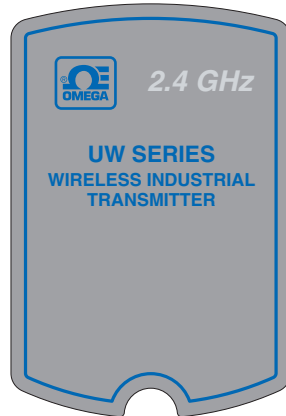

Figure 1-2. UWIR-2A-NEMA  
UWIR-2A-NEMA-HT  
Front View



Figure 1-3. UWIR-2A-NEMA,  
UWIR-2A-NEMA-HT  
Rear View

## 1.4 Statement on FCC and CE Marking

### 1.4.1 FCC Marking

FCC ID: OUR-XBEEPRO IC #4214A-XBEEPRO

This device complies with Part 15 of the FCC rules. Operation is subject to the following two conditions: 1.) This device may not cause harmful interference. 2.) This device must accept any interference received, including interference that may cause undesired operation.

### 1.4.2 CE Marking

It is the policy of OMEGA to comply with all worldwide safety and EMI/EMC regulations that apply. OMEGA is constantly pursuing certification of its products to the European New Approach Directives. OMEGA will add the CE mark to every appropriate device upon certification.

## 1.5 General Description and System Components

### 1.5.1 General Description

The UWIR-2A-NEMA, and UWIR-2A-NEMA-HT Wireless Infrared Transmitter provides non-contact temperature measurement for industrial applications. The unit measures a temperature range of -18 to 538°C (0 to 1000°F). The miniature sensor head design at 2.5 Dia x 6.3 cm L (1 x 2.5") is ideal for measuring temperature in confined, and hard to reach places. The aluminum sensor head, as well as the rugged electronic housing, are NEMA 4 rated. The sensor head is connected to the electronic housing via a 1.82 m (6') shielded cable.

The UWIR-2A-NEMA is offered in a high temperature model which allows for operating temperature of 0 to 85°C, as opposed for the standard 0 to 70°C.



Figure 1-4. Transmitter With Connectors

---

## Section 2 – Hardware

It is important that you read this manual completely and follow all safety precautions before operating this instrument.

### 2.1 Package Inspection

Remove the packing list and verify that you have received all your equipment. If you have any questions about the shipment, please call our Customer Service Department at

**1-800-622-2378 or 203-359-1660.** We can also be reached on the Internet at

**omega.com**

**e-mail: cservice@omega.com**

When you receive the shipment, inspect the container and equipment for any signs of damage. Note any evidence of rough handling in transit. Immediately report any damage to the shipping agent.

---

**NOTE:**

The carrier will not honor any damage claims unless all shipping material is saved for inspection. After examining and removing contents, save packing material and carton in the event reshipment is necessary.

---

### 2.2 Included Items

The following items are supplied in the box.

- 1 UWIR-2A-NEMA or UWIR-2A-NEMA-HT transmitter including the sensor head and 1.82 m (6') shielded cable
- 1 User's Guide
- 1 Sensor head mounting nut
- 3.6V Lithium Battery

## Section 3 - Operation

### 3.1 Main Transmitter Board

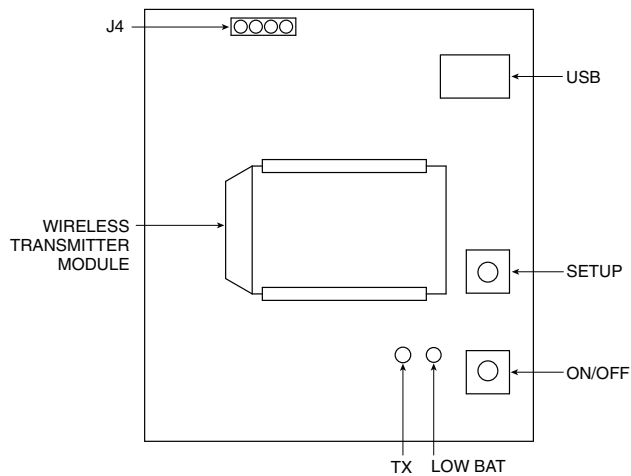

Figure 3-1. Main Transmitter Board

### 3.2 Ambient Temperature

The Sensing head can operate in an ambient temperature of 0 to 70°C (32 to 158°F). The Sensing head in the high temperature model (-HT) can operate in an ambient temperature of 0 to 85°C (32 to 185°F) without any cooling required. The Sensing head can operate up to 200°C (392°F) using the water cool jacket accessory OS100-WC (See Figure 3-5, page 3-3). There is a warm up period of 3 minutes after power up. After the warm up period, temperature measurement can be made. When the ambient temperature around the sensor head changes abruptly, the sensor head goes through thermal shock. It takes a certain amount of time for the sensor head to stabilize to the new ambient temperature. For example, it takes about 30 minutes for the sensor head to stabilize going from 25° to 50°C (77 to 122°F) ambient temperature. The sensor head dimensions are shown in Figure 3-2.

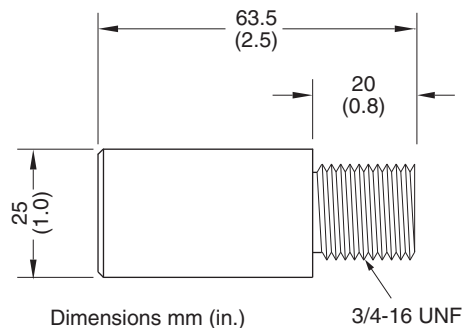

Figure 3-2. Sensor Housing (Dimensions for Both Regular and High Temperature Models)

### 3.3 Atmospheric Quality

Environments with smoke, dust, and fumes dirty up the optical lens, and cause erroneous temperature readings. To keep the surface of the optical lens clean, the air purge collar accessory is recommended, see model OS100-AP



### 3.4 Optical Field of View

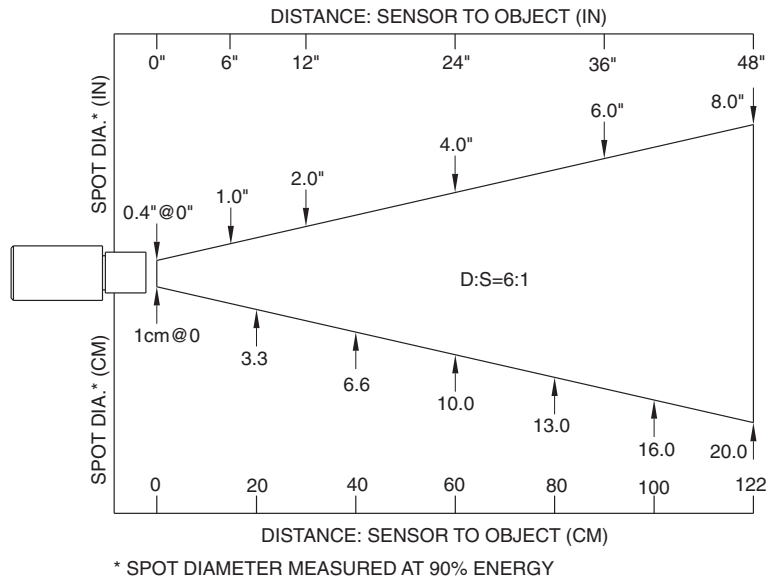

Figure 3-3. Optical Field of View

### 3.5 Adding Extension Cable

You can add an extension cable between the Sensor Head and the main electronic housing up to 15.2 m (50 feet).

**NOTE:**

After adding the extension cable, make sure when you run the transmitter setup utility you change the "Cable Length" value.

### 3.6 Sensor Head Accessories

The following figures show the Sensor Head Mounting Bracket (OS100-MB), Water Cooling Jacket (OS100-WC) and Air Purge Collar (OS100-AP).

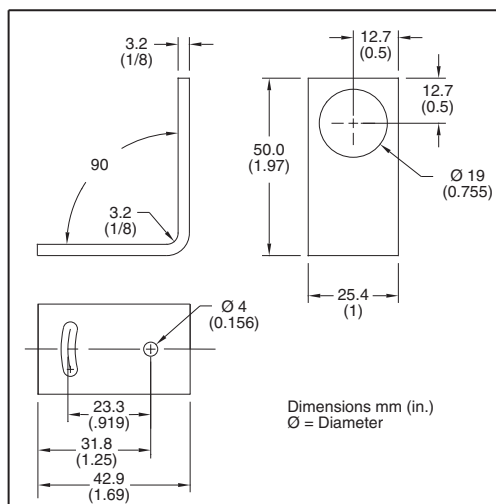

Figure 3-4. Sensor Head Mounting Bracket (OS100-MB)

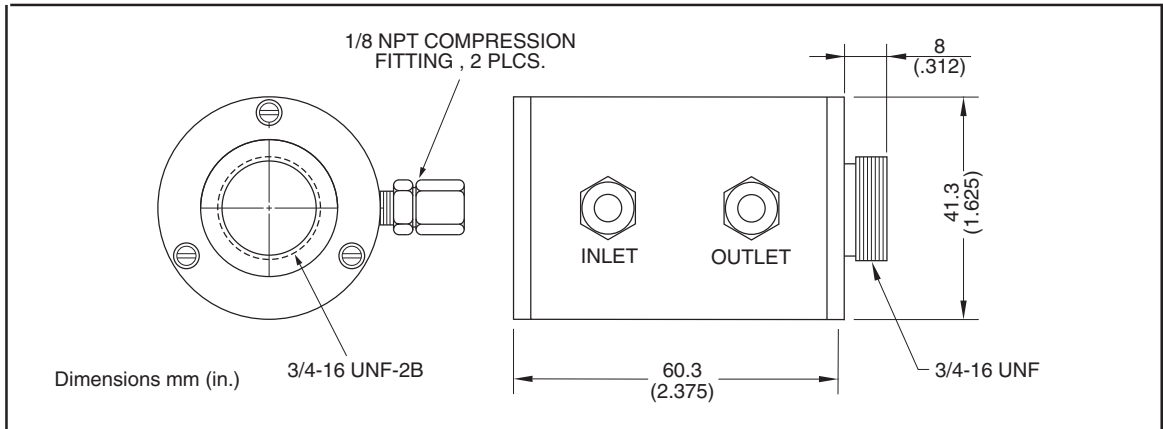

Figure 3-5. Water Cooling Jacket (OS100-WC)

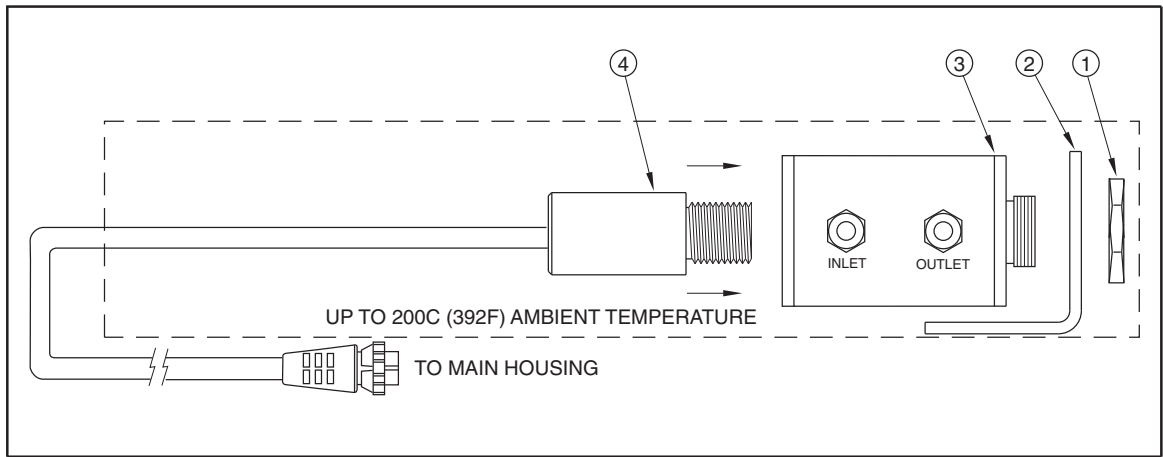

Figure 3-6. Water Cool Jacket Installation

- (1) Mounting Nut, (2) Mounting Bracket, (3) Water Cool Jacket, (4) Sensor Head

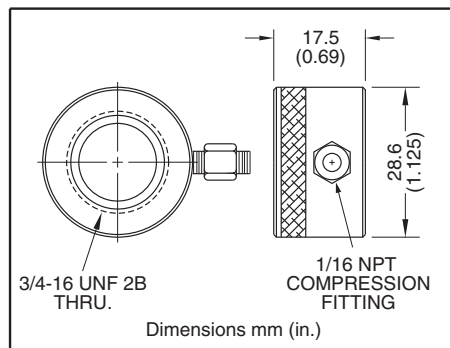

Figure 3-7. Air Purge Collar (OS100-AP)

## Section 4 - Laser Sight Accessory

### 4.1 Warning and Cautions

---

**CAUTION:**

You may receive harmful laser radiation exposure if you do not adhere to the warnings listed below:

Use of controls or adjustments or performance of procedures other than those specified here may result in hazardous radiation exposure.

**Do not** look at the laser beam coming out of the lens or view directly with optical instruments - eye damage can result.

Use extreme caution when operation the laser sight accessory

Never point the laser accessory at a person

Keep out of the reach of all children

---

---

**WARNING:**

Do not attempt to open the laser sight accessory. There are no user serviceable parts inside.

---

### 4.2 Operating the Laser Sight Accessory

The laser sight accessory screws onto the front of the sensor head. This accessory is only used for alignment of the sensor head to the target area. After the alignment process, the accessory has to be removed from the front of the sensor head before temperature measurement. The laser sight accessory is powered from a small compact battery pack (included with the accessory). Connect the battery pack to the accessory using the cable provided. Aim at the target, and turn on the battery power using the slide switch on the battery pack. Adjust the sensor head position so that the laser beam points to the center of the target area. Turn off the battery pack, and remove the laser sighting accessory from the sensor head. See Figure 4-1, Page 4-2 for reference.

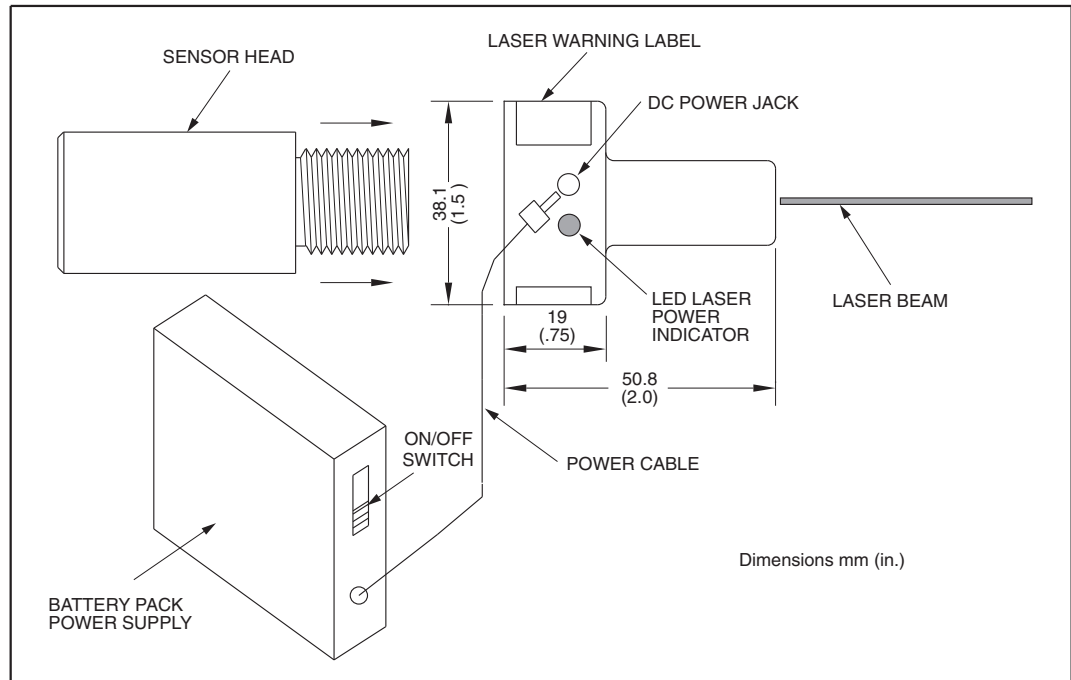

Figure 4-1. Laser Sighting Accessory (OS100-LS)



Figure 4-2. Laser Warning Label

## Section 5 – Software

### 5.1 Getting Started

The following program files are included on the TC-Central User Software CD supplied with your Receiver. These files can also be downloaded from the omega.com website should you misplace your CD.

- End Device Setup Utility Software
- Receiver / Transceiver Setup Utility Software
- TC-Central Measurement and Data Logging Software

### 5.2 Software Installation

#### 5.2.1 System Requirements

Your PC should meet the following minimum requirements:

- Pentium Class processor
- Hard Drive Space: 210 meg
- Ram: 256 meg or higher
- 1 Available USB Port
- 1 CD-ROM Drive
- Windows 2000, XB, or Vista (32bit) Operating System

#### 5.2.2 Software Installation

Insert the TC-Central User CD that was included with your receiver unit into the CD-ROM drive on your PC. Your system should begin the installation process automatically.



Figure 5-1. Software - Welcome Screen

This welcome screen should be visible on your computer screen. To continue with installing the program, click the "Next>" button.

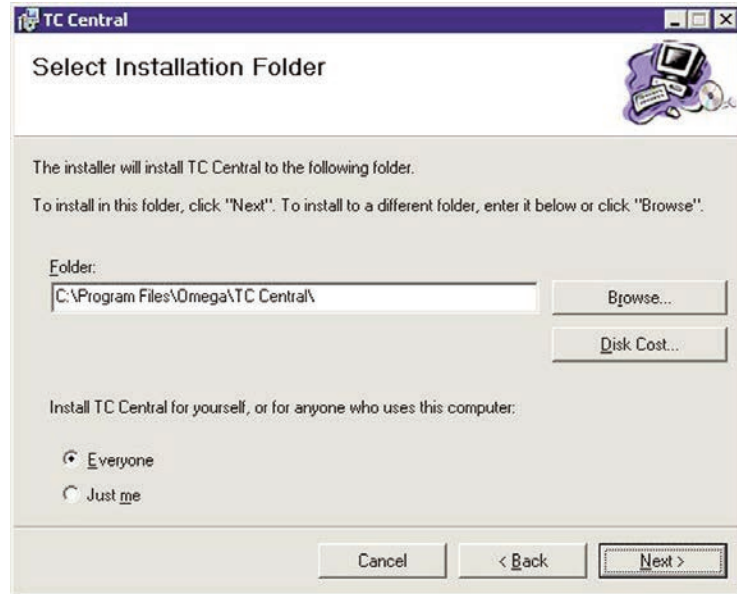

Figure 5-2. Software - Select Installation Screen

From this screen you select the folder where you want the program files installed on your PC. The default setting will install the software under your “Program” folders in a new folder named “Omega”. To continue with installing the program click the “Next >” button.

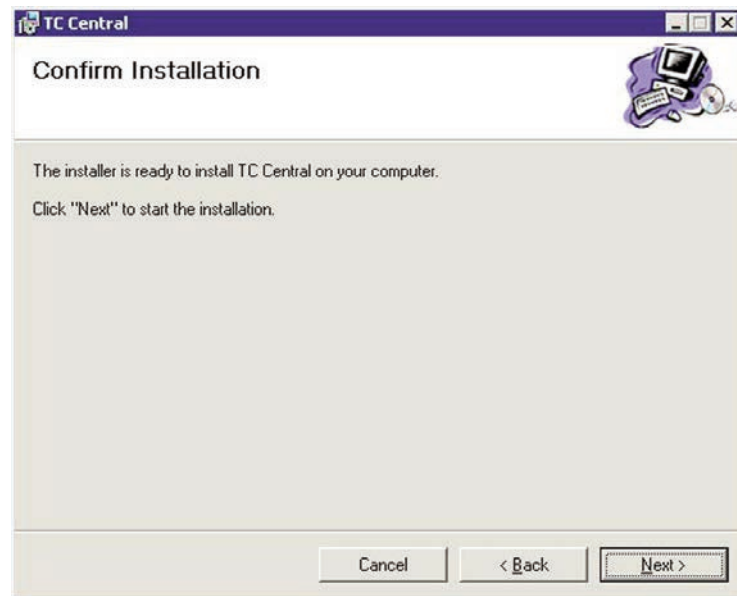

Figure 5-3. Software - Confirm Installation Screen

The setup wizard now has all the information to complete the installation of the software on your PC. To continue with installing the program click the “Next >” button.



Figure 5-4. Software - License Agreement Screen

From this screen you must select "Agree" to continue installing your program. After making your selection click the "Next >" button. The setup wizard will now install the software.

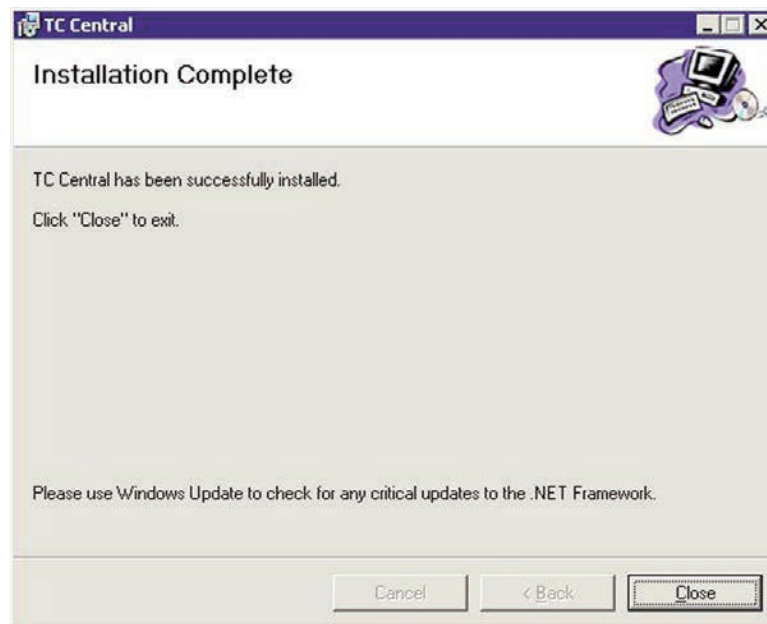

Figure 5-5. Software - Installation Complete Screen

Congratulations! You have just successfully installed the TC-Central Program on your PC. To end installing the program and close the setup wizard click the "Close" Button.

## Section 6 - End Device Operation

### 6.1 Setup and Configuration

#### 6.1.1 Connecting your device

Connect the USB cable to your connector/transmitter unit and also to an available USB port on your computer. See figure below. This cable was provided in the box with your receiver unit. This same cable is used for programming your End Device and for receiver operation later.



Figure 6-1. USB Cable

#### 6.1.2 Configure Your End Device

Now that you have connected your USB cable to your PC and transmitter you will complete the following steps to configure your End Device before placing the unit into operation. You will be using the configuration software utility that you installed onto your PC in Section 5. If you have not installed the configuration software utility you should do so now. During this procedure you will be setting the following parameters in your transmitter.

#### 6.1.3 Button Operation

(1.) "PRESS ON/OFF"

The "PRESS ON/OFF" button on the front of your connector/transmitter is used to turn your unit "ON" or "OFF"

(2.) "PRESS SETUP"

The "PRESS SETUP" button on the front of your connector/transmitter is only used during the setup and configuration of your unit.

#### 6.1.4 Indicator Lights

(1) Transmit (TX) Green Indicator Light

The green indicator light marked "TX" on the front of the connector/transmitter will blink every time the unit sends data to the receiving unit. Example: If you selected a 5 sec sample rate the green TX led will blink one time every 5 seconds.

(2) Low Battery (Low Bat) Red Indicator Light

The red indicator light marked "Low Bat" on the front of the connector/transmitter will turn on when the battery reaches a level at or below the power level required for normal operation. When this indicator turns on it's time to install a fresh battery in your unit. For procedures on how to change your battery see Section 6.3.



### Channel Number

This sets a unique address number into your transmitter. Later, when you set up your measurement software you will again set channel numbers to receive readings from the corresponding unit(s). Each unit must be set for a different channel number for your system to operate correctly.

---

**NOTE:**

---

If you will be using more than one receiver unit in your area it is important to set the transmitter address numbers to be a corresponding number in your TC-Central software.

**Example Rate**

For the first receiver: Set the channels on your transmitters to 101, 102, 103, 104, etc. Then set the channels in your TC-Central user software to match.

For the second receiver: Set the channels on your transmitters to 201, 202, 203, 204, etc.

Then set the channels in your TC-Central user software to match.

This numbering scheme can be expanded to match the number of receivers you are using.

---

### Sample Rate

This will program your End Device to transmit 1 data reading to your receiver at a specified time interval. Available settings are 2, 3, 5, 15, 30, 45, 60, 75 or 90 seconds

---

**NOTE:**

---

The sample rate you set will have the most direct effect on the life of the battery in your End Device. It is recommended that you set the longest sample time that your application can live with to extend time between battery replacement. See Section 6.3 for more information on battery

---

### STEP 1. Enter the "SETUP" mode.

To place your transmitter into the "SETUP" mode for programming follow this procedure.

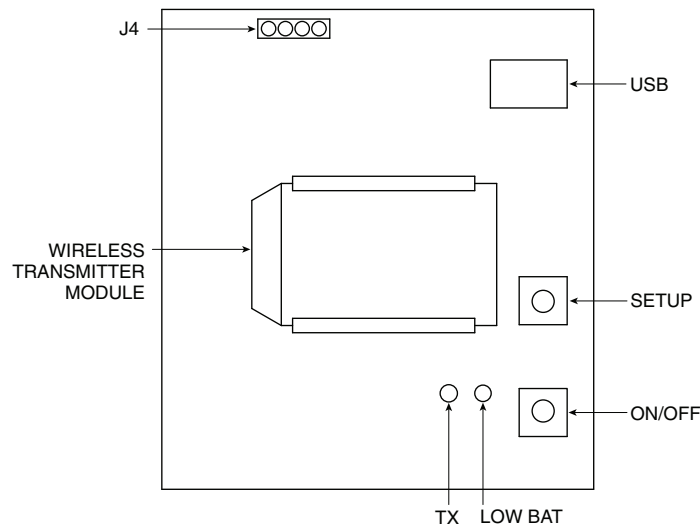

Figure 6-2. Main Transmitter Board

Press and hold the "ON/OFF" button. While the "ON/OFF" button is being held, press the "SETUP" button one time and then release the "ON/OFF" button. The green (TX) indicator on the front of your device should be blinking at a steady rate. This indicates your End Device is ready to run the configuration utility software.

### STEP 2. Launch Setup Utility Program.

To launch the End Device setup utility program on your PC begin by accessing the "Programs" list under your "Start Menu".

Scroll through the list of to find the Omega "TC-Central" folder, then select the End Device Configuration Program.

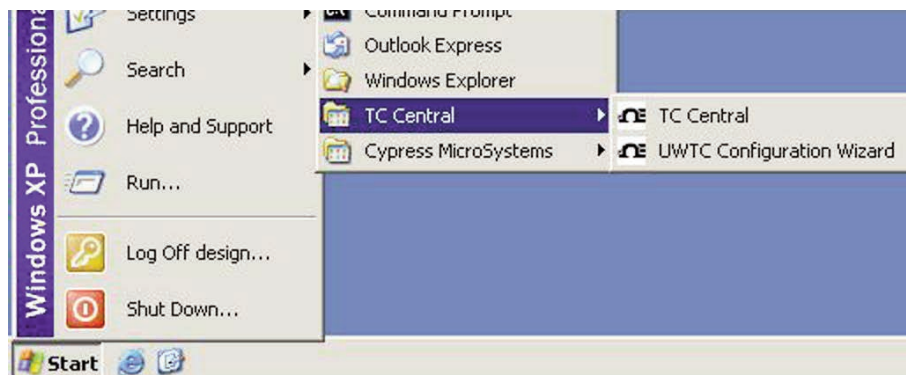

Figure 6-3. Launch Setup Utility Screen

### STEP 3. Programming your settings into your End Device



Figure 6-4. Utility Program - Welcome Screen

After starting the setup utility program this will be the first screen you will see. Click the "Next >" button to proceed and continue setting up your End Device. Each screen will provide instruction details on how to proceed.



Figure 6-5. Utility Program - Connect To Transmitter Screen

If you have not already connected your End Device to a USB port on your PC you must do this now before continuing. After your unit has been connected click the "Next >" button to proceed and continue setting up your unit.

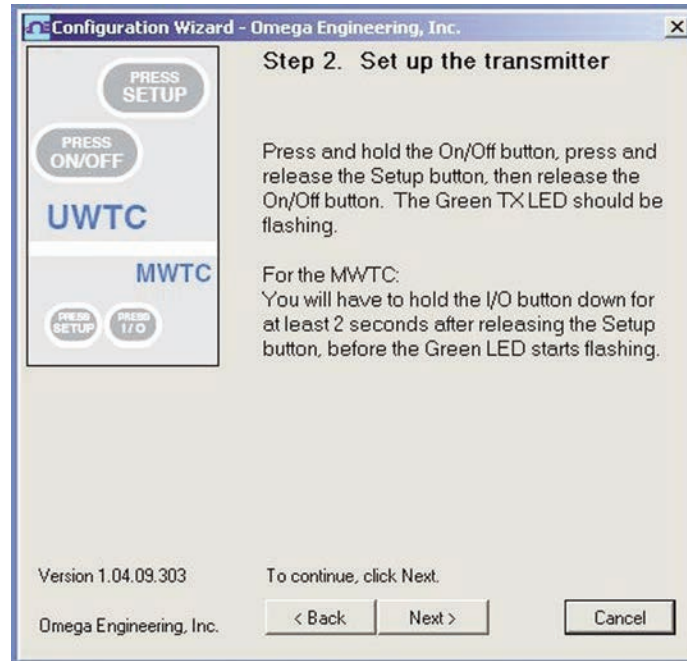

Figure 6-6. Utility Program - Setup Transmitter Screen

If you have not already placed your End Device into the "Setup" mode you should do this now before continuing. After your unit has been placed into the "Setup" mode click the "Next >" button to proceed and continue setting up your unit.

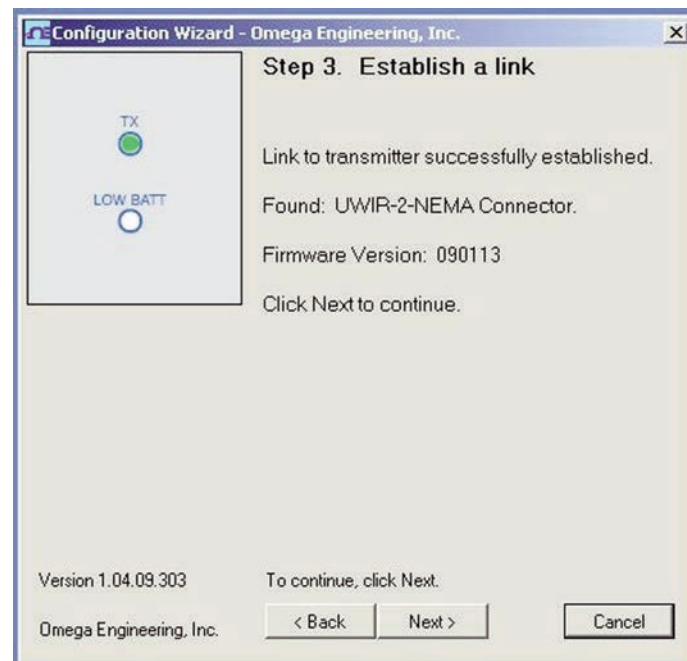

Figure 6-7. Utility Program - Establish Link Screen

After successful communication between your connector/transmitter has been established you can click the "Next >" button to proceed and continue setting up your connector/transmitter. If you did not receive this confirmation of proper communication you should click the "Back" button to try connecting again.

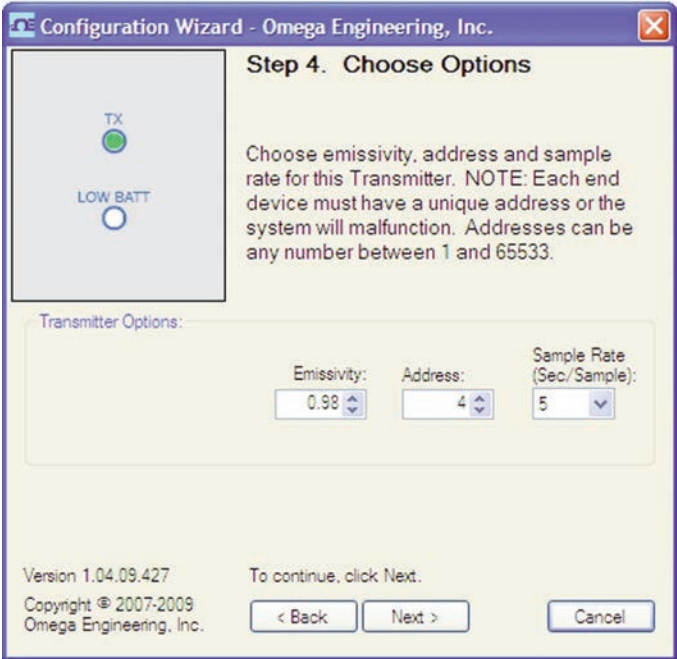

Figure 6-8. Utility Program - Choose Options Screen

From this screen you will select the main operating settings for your end device. (Note: Each end device must have a different address number for proper operation). After making your selections click the “Next >” button to proceed and program your settings into your unit.

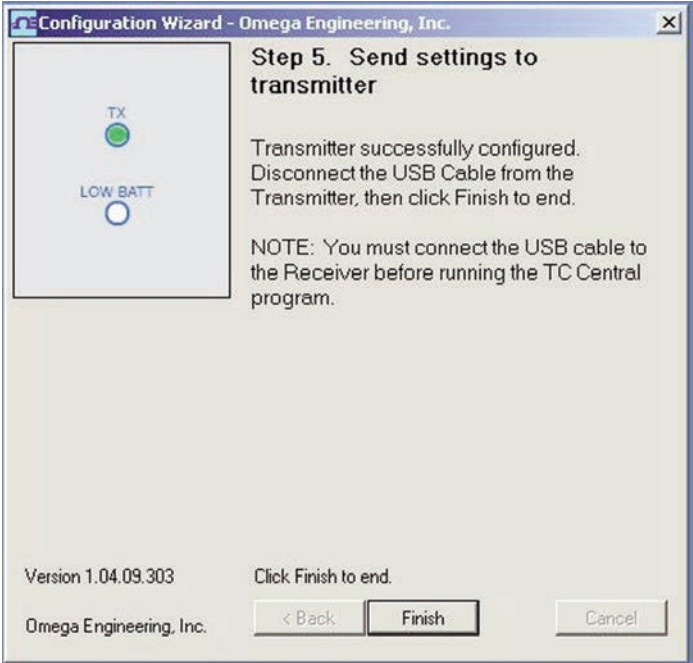

Figure 6-9. Utility Program - Send To Transmitter Screen

Congratulations! You have successfully programmed your end device. After your unit has been programmed click the “Finish” button to close the utility program.

## 6.2 Mounting, Installation, Antenna Connection and DIN Rail Mounting Bracket Installation

### 6.2.1 Mounting

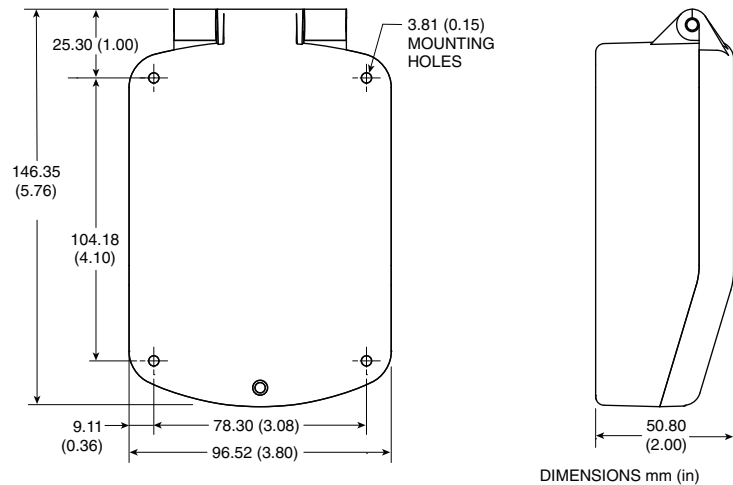

Figure 6-10. Mounting

When mounting your end device, care should be taken to make sure it is as far away from any metal objects. If nearby metal gets too close to your unit, it has the potential to interfere with the way the unit radiates and may cause signal loss or possibly even the inability to communicate at all with your receiver.

### 6.2.2 Installation

When installing your End Device it is important to position your device in such a way as to optimize the antenna location within what's known as the "Fresnel Zone".

The Fresnel Zone can be thought of as a football-shaped invisible tunnel between two locations that provides a path for RF signals between your End Device and your receiver.

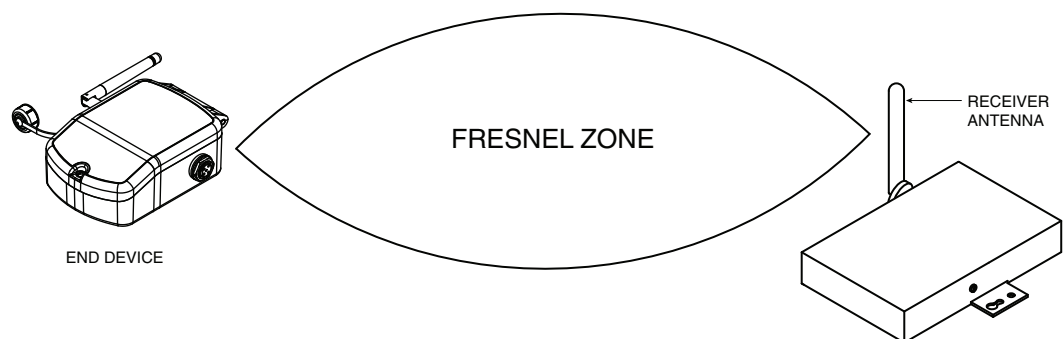

Figure 6-11. Fresnel Zone

In order to achieve maximum range, the football-shaped path in which radio waves travel must be free of all obstructions. Obstacles in the path (especially metal) will decrease the communication range between your End Device and receiver. Also, If the antennas are mounted just barely off the ground, over half

of the Fresnel zone ends up being obstructed by the earth resulting in significant reduction in range. To avoid this problem, the antennas should be mounted high enough off of the ground so that the earth does not interfere with the central diameter of the Fresnel zone.

**NOTE:**

It is important to understand that the environment may change over time due to new equipment or machinery being installed, building construction, etc. If new obstacles exist between your End Device and receiver, the devices can be raised on one end or on both ends to hopefully clear the Fresnel Zone of obstructions.

**NOTE:**

No co-location with other radio transmitters is allowed. By definition, co-location is when another radio device or the device's antenna is located within 20 cm of your connector/transmitter and can transmit simultaneously with your unit.

**NOTE:**

Never install multiple End Devices within 20 cm or less from each other.

**NOTE:**

Never use your UWIR End Device as a portable device. Your unit has been designed to be operated in a permanent installation only.

### 6.2.3 Antenna Connection

Your End Device has been shipped to you with a standard approved antenna.

**NOTE:**

Use of any other antenna than what's supplied with your End Device will void all FCC, IC and CE regulatory compliance.

In some cases, a short RF cable may be used to connect an antenna to your end device. Please note that RF extension cables will always add some loss to the transmitting signal strength. The longer the cable, the more signal will be lost over that cable. Because of this, the length of the cable should be kept as short as possible.

#### 6.2.4 DIN Rail Mounting Bracket Installation

To install the DIN Rail Mounting Bracket accessory (UWM-DINRAIL) you must first remove the one screw located on the lid of the enclosure. This will allow you access to the mounting holes.

Place all four #4-40 screws with threaded standoffs into each mounting hole. Screw on the DIN Rail Mounting Bracket sub assembly to the bottom of the enclosure using the #4-40 screws.

Close the unit by threading the one screw located on the lid of the enclosure to the bottom enclosure.

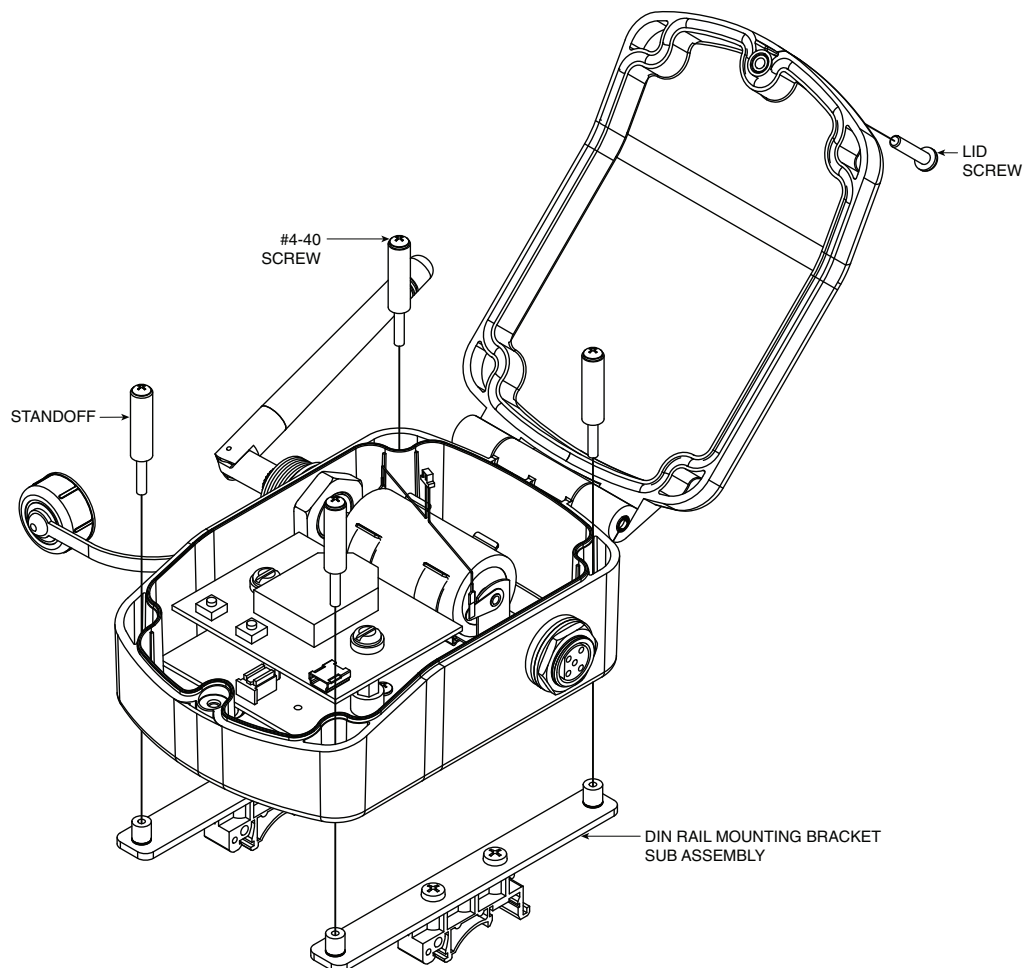

Figure 6-12. DIN Rail Mounting Bracket Installation



## 6.3 Battery Replacement

### 6.3.1 Model UWIR-2A-NEMA and UWIR-2A-NEMA-HT

To install or replace the battery in your End Device you must first remove the one screw located on the Lid of the enclosure. This will allow you to access the battery compartment.

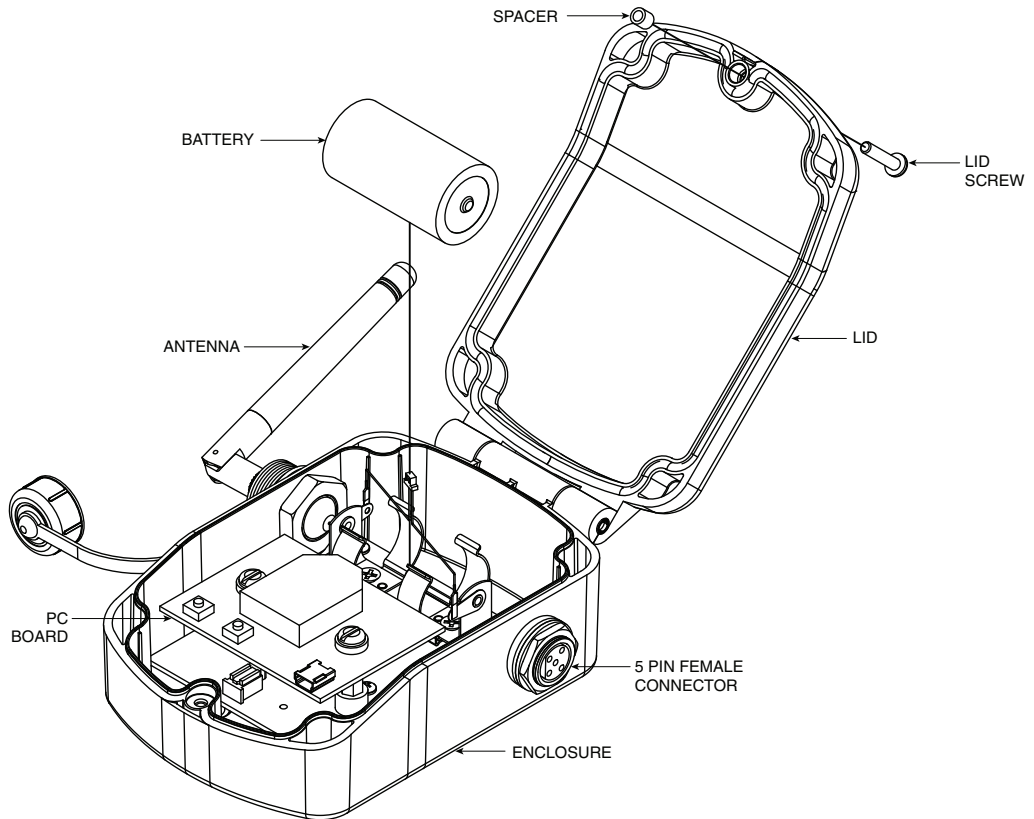

Figure 6-13. Battery Replacement

Your End Device is equipped with a “C” size lithium power cell assembly. To install a replacement battery assembly follow steps outlined here.

- A. Remove the old power cell from the battery holder.
- B. Install your new battery assembly into the housing in the same position as the old battery was located.
- C. Installation complete

**CAUTION:**

Installing your end device in an application where the unit will be exposed to ambient temperatures above or below the operating limits specified in this manual will damage your unit and cause the unit to malfunction and produce incorrect operation.

## 6.4 Input Connection

### 6.4.1 Models UWIR-2A-NEMA and UWIR-2A-NEMA-HT

The UWIR can provide fast, accurate reading from the IR sensor with a 5 pin connector.

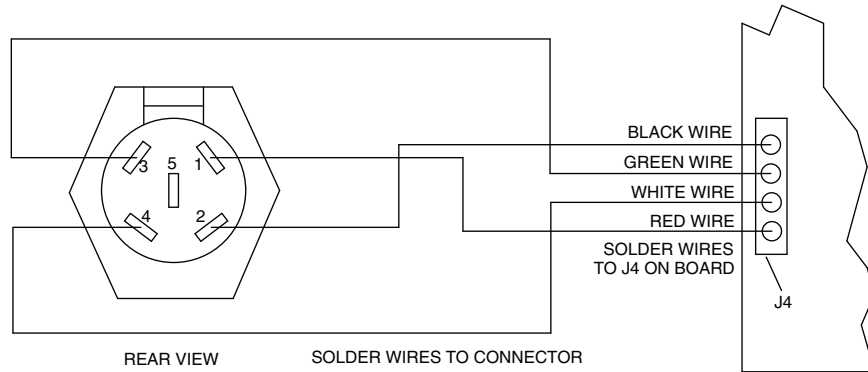

Figure 6-14. Input Diagram for 5 Pin Connector

## Section 7 - System Operation

### 7.1 Introduction

Compared to wired systems, a wireless system provides much simpler installation. Based on the physical principle of the propagation of radio waves, certain basic conditions should be observed. The following simple recommendations are provided to ensure proper installation and correct operation of your wireless system.

### 7.2 RF Communication Basics

The Model UWIR-2A-NEMA and UWIR-2A-NEMA-HT sends wireless transmissions to a receiver. The receiver checks the incoming data for accuracy and processes this data for use by the measurement software on your PC. Radio signals are electromagnetic waves, hence the signal becomes weaker the further it travels. While radio waves can penetrate some solid materials like a wall, they are dampened more than when a direct line-of-sight between the transmitting and receiving antenna exist.

### 7.3 Basic System Overview

A basic wireless thermocouple system is comprised of only two main components; a signal conditioner with a built-in battery powered 2.4 GHz radio transmitter, and a USB powered 2.4 GHz radio receiver.

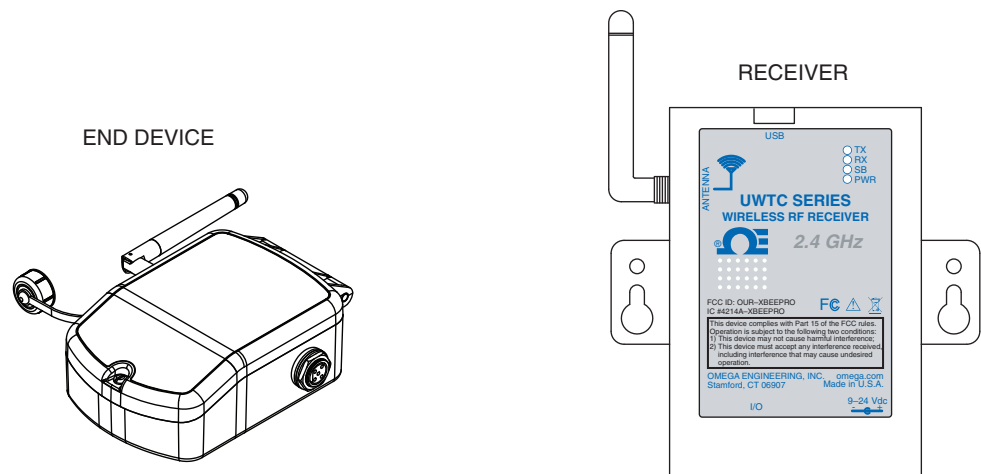

Figure 7-1. End Device/ Receiver

#### NOTE:

Up to 48 end devices can be used with one receiver.

## 7.4 Environment/Operating Conditions

### 7.4.1 Environment

Omega's NEMA wireless end devices and receiver units have been designed to be fixed and operated in both indoor and outdoor environments; they are also weather-resistant. Care should be taken to prevent the components of your wireless system from being exposed to toxic chemicals and extreme cold or hot temperature that are outside the specifications listed in this manual.

### 7.4.2 Operating Conditions

The following is a list of basic good practice you should apply when operating your wireless system.

- Never operate your wireless device or receiver outside the recommended environmental limits specified in this manual.
- Never operate your wireless end device or receiver in flammable or explosive environments.
- Never use your wireless end device or receiver in medical, nuclear or other dangerous applications where an interruption of readings can cause damage or harm.
- Never operate your end device or receiver with any other battery or power source than what's specified in this manual or on the battery compartment label.
- No co-location with other radio transmitters is allowed. By definition, co-location is when another radio device or its antenna is located within 20 cm of your end device and can transmit simultaneously with your end device.
- Never install end devices within 20 cm or less from each other.
- Never use your end device as a portable device. Your unit has been designed to be operated in a permanent installation.
- Never install and/or operate your end device closer than 20 cm to nearby persons.
- Never operate your end device with any other antenna than what is supplied or listed here in this manual for approved use.

## 7.5 Transmit Rate vs. Battery Life

Many factors such as ambient temperature conditions and transmitting rate can have a large effect on the life of the battery used in your end device. Transmitting data places a large demand on the battery in your unit. The transmit rate is the single most contributing factor in the life of your battery. The slower the transmit rate you set, the longer the battery in your device will last. The table below gives some estimates on how long the battery should last vs. the transmit rate you selected when you setup your end device and under normal operating conditions.

For Model: UWIR-2A-NEMA, UWIR-2A-NEMA-HT

<b>Transmission Interval</b>	<b>Battery Life (Months)</b>
2 Seconds	4
10 Seconds	7.5
30 Seconds	16.5
60 Seconds	30

## Section 8 – Service & Calibration

Your UWIR-2A-NEMA, UWIR-2A-NEMA-HT Weather Resistant Non-Contact Infrared Temperature Sensor with Wireless Transmitter has been built and factory calibrated to meet or exceed the specifications listed here in this manual. Information is provided below on how to have your unit serviced.

### 8.1 Service and Calibration

If any of your wireless system components require service or re-calibration, please call our Customer Service Department at 1-800-622-2378 or 203-359-1660. They will assist you in arranging the return of your device. We can also be reached on the Internet at [www.omega.com](http://www.omega.com), e-mail: [cservice@omega.com](mailto:cservice@omega.com)

## Section 9 – Specifications

### 9.1 General

<b>Temperature Range:</b>	-18 to 538°C (0 to 1000°F) Accuracy @ 22°C (72°F)
<b>Ambient Temperature and Emissivity of 0.95 or Greater:</b>	±2% rdg or 2.2°C (4°F), whichever is greater
<b>Optical Field of View:</b>	6:1 (distance/spot size)
<b>Sensor Head Cable Extension:</b>	Up to 15 m (50') total
<b>Repeatability:</b>	±1% rdg
<b>Spectral Response:</b>	5 to 14 microns
<b>Response Time:</b>	100 ms (0 to 63% of final value)
<b>Emissivity Range:</b>	0.1 to 1.00, adjustable
<b>Operating Temperature</b>	
<b>Wireless Transmitter:</b>	-10 to 70°C (14 to 158°F)
<b>Sensor Head:</b>	0 to 70°C (32 to 158°F)
<b>Sensor Head (-HT Model):</b>	0 to 85°C (32 to 185°F)
<b>Sensor Head with OS100-WC (Water Cooling Jacket):</b>	0 to 200°C (32 to 392°F)
<b>Operating Relative Humidity:</b>	Less than 95% RH, non-condensing
<b>Water Flow Rate for OS100-WC:</b>	0.25 GPM, room temperature
<b>Thermal Shock:</b>	About 30 min for 25°C (77°F) abrupt ambient temperature change
<b>Warm-Up Period:</b>	3 min
<b>Air Flow Rate (OS100-AP):</b>	1 CFM (0.5 L/s) (1 x 2.5")
<b>Laser Sight Accessory (OS100-LS) Wavelength (Color):</b>	630 to 670 nm (red)
<b>Operating Distance(Laser Dot):</b>	Up to 9.1 m (30')
<b>Max Output Optical Power:</b>	Less than 1 mW @ -6°C (22°F) ambient temperature
<b>European Classification:</b>	Class 2, EN60825-1/11.2001
<b>Max Operating Current:</b>	45 mA @ 3 Vdc
<b>FDA Classification:</b>	Complies with 21 CFR 1040.10, Class II laser product
<b>Beam Diameter:</b>	5 mm (0.20")
<b>Beam Divergence:</b>	<2 mrad
<b>Operating Temperature:</b>	0 to 50°C (32 to 122°F)
<b>Operating Relative Humidity:</b>	Less than 95% RH, non≠condensing
<b>Power Switch:</b>	On/off slide switch on the battery pack
<b>Power Indicator:</b>	Red LED
<b>Power:</b>	Battery pack (included), 3 Vdc (consists of two 1.5 Vdc "AA" lithium batteries)

<b>Dimensions:</b>	38 Dia. x 50.8 mm L (1.5 x 2")
<b>Wireless Transmitter Computer Interface:</b>	USB
<b>Transmit Sample Rate:</b>	Programmable from 1 sample/minute to 1 sample/every 2 seconds radio frequency (RF) transceiver
<b>Carrier:</b>	ISM 2.4 GHz, direct sequence spread spectrum
<b>RF Output Power:</b>	10Bm (10 mW)
<b>Range of RF Link:</b>	
Up to 120 m (400'):	Outdoor line of sight
Up to 40 m (130'):	Indoor/urban
<b>RF Data Packet Standard:</b>	IEEE 802.15.4, open communication architecture
<b>Software (Included Free):</b>	Requires Windows® 2000, XP or Vista operating system
<b>Power:</b>	One 3.6V, lithium "C" cell (included)
<b>Battery Life (Typical):</b>	2.5 yrs. at 1 sample/minute reading rate @ 25°C
<b>Enclosure:</b>	NEMA 4X (IP65) polycarbonate
<b>Dimensions:</b>	
Enclosure:	145.8 L x 94.7 W x 50.8 mm H (5.74 x 3.73 x 2")
Sensor Head:	25.4 OD x 63.5 mm L (1 x 2.5")

## 9.2 Laser Sight Accessory (OS100-LS)

<b>Wavelength (Color):</b>	630 to 670 nm (Red)
<b>Operating Distance (Laser Dot):</b>	Up to 9.1 m (30')
<b>Max Output Optical Power:</b>	Less than 1 mW at 22°F ambient temperature
<b>European Classification:</b>	Class 2, EN60825-1/11.2001
<b>Maximum Operating Current:</b>	45 mA @ 3 Vdc
<b>FDA Classification:</b>	Complies with 21 CFR 1040.10, Class II Laser Product
<b>Beam Diameter:</b>	5 mm
<b>Beam Divergence:</b>	< 2 mrad
<b>Operating Temperature:</b>	0 to 50°C (32 to 122°F)
<b>Operating Relative Humidity:</b>	Less than 95% RH, non-condensing
<b>Power Switch:</b>	ON/OFF, slide switch on the battery pack
<b>Power Indicator:</b>	Red LED
<b>Power:</b>	Battery pack (included), 3 Vdc (consists of two 1.5 Vdc "AA" lithium batteries)
<b>Laser Warning Label:</b>	Located on the head sight circumference
<b>Identification Label:</b>	Located on the head sight circumference
<b>Dimensions:</b>	38 Dia. x 50.8 mm L (1.5 x 2")



## Section 10 – Emissivity Table

<b>METALS .....</b>	<b>Emissivity</b>
Aluminum – pure highly polished plate.....	0.04 to 0.06
Aluminum – heavily oxidized.....	0.20 to 0.31
Aluminum – commercial sheet .....	0.09
Brass – dull plate .....	0.22
Brass – highly polished, 73.2% Cu, 26.7% Zn .....	0.03
Chromium – polished .....	0.08 to 0.36
Copper – polished.....	0.05
Copper – heated at 600°C (1112°F) .....	0.57
Gold – pure, highly polished or liquid.....	0.02 to 0.04
Iron and steel (excluding stainless) – polished iron .....	0.14 to 0.38
Iron and steel (excluding stainless) – polished cast iron.....	0.21
Iron and steel (excluding stainless) – polished wrought iron .....	0.28
Iron and steel (excluding stainless) – oxidized dull wrought iron .....	0.94
Iron and steel (excluding stainless) – rusted iron plate.....	0.69
Iron and steel (excluding stainless) – polished steel.....	0.07
Iron and steel (excluding stainless) – polished steel oxidized at 600°C (1112°F) .....	0.79
Iron and steel (excluding stainless) – rolled sheet steel.....	0.66
Iron and steel (excluding stainless) – rough steel plate .....	0.94 to 0.97
Lead – gray and oxidized .....	0.28
Mercury.....	0.09 to 0.12
Molybdenum filament.....	0.10 to 0.20
Nickel – polished.....	0.07
Nickel – oxidized at 649 to 1254°C (1200 to 2290°F).....	0.59 to 0.86
Platinum – pure polished plate .....	0.05 to 0.10
Platinum – wire.....	0.07 to 0.18
Silver – pure and polished .....	0.02 to 0.03
Stainless steel – polished.....	0.07
Stainless steel – Type 301 at 232 to 942°C (450 to 1725°F).....	0.54 to 0.63
Tin – bright.....	0.06
Tungsten – filament .....	0.39
Zinc – polished commercial pure .....	0.05
Zinc – galvanized sheet.....	0.23

<b>NON-METALS</b> .....	<b>Emissivity</b>
Asbestos Board.....	0.96
Asphalt, tar, pitch.....	0.95 to 1.00
Brick – red and rough.....	0.93
Brick – fireclay.....	0.75
Carbon – filament.....	0.53
Carbon – lampblack - rough deposit.....	0.78 to 0.84
Glass - Pyrex, lead, soda.....	0.85 to 0.95
Marble – polished light gray.....	0.93
Paints, lacquers, and varnishes – Black matte shellac.....	0.91
Paints, lacquers, and varnishes – aluminum paints.....	0.27 to 0.67
Paints, lacquers, and varnishes – flat black lacquer.....	0.96 to 0.98
Paints, lacquers, and varnishes – white enamel varnish.....	0.91
Porcelain – glazed.....	0.92
Quartz – opaque.....	0.68 to 0.92
Roofing Paper.....	0.91
Tape – Masking.....	0.95
Water.....	0.95 to 0.96
Wood – planed oak.....	0.90

---

## Section 11 – Approvals, Regulatory Compliance

---

**NOTE:**

All approvals outlined in this manual are based on testing that was done with antennas that are supplied with your Wireless Series System Components. Removing and or installing a different antenna will void the product compliance demonstrated in these documents.

---

### 11.1 FCC (Domestic Use)

For United States: FCC ID: OUR-XBEEPRO  
For Canada: IC #4214A-XBEEPRO

This device complies with Part 15 of the FCC rules. Operation is subject to the following two conditions: 1.) This device may not cause harmful interference. 2.) This device must accept any interference received, including interference that may cause undesired operation.

---

**WARNING:**

To satisfy FCC RF exposure requirements for mobile transmitting devices, a separation distance of 20 cm or more should be maintained between the antenna of this device and persons during device operation. To ensure compliance, operations at closer than this distance is not recommended. The antenna used for this transmitter must not be co-located in conjunction with any other antenna or transmitter.

---

### 11.2 FCC International Usage and CE Marking

---

**NOTE:**

It is your (the user's) responsibility to insure that these products are operated within the guidelines here in this manual and in conformance with all local, state, federal or national regulations and laws of the country they are being operated in.

Transmitting Power —Your Wireless Series System Components have been designed, manufactured and tested so that the transmitting power of your connector transmitter will not exceed 10 dBm.

---



---

**NOTES:**

## WARRANTY/DISCLAIMER

OMEGA ENGINEERING, INC. warrants this unit to be free of defects in materials and workmanship for a period of **13 months** from date of purchase. OMEGA's WARRANTY adds an additional one (1) month grace period to the normal **one (1) year product warranty** to cover handling and shipping time. This ensures that OMEGA's customers receive maximum coverage on each product.

If the unit malfunctions, it must be returned to the factory for evaluation. OMEGA's Customer Service Department will issue an Authorized Return (AR) number immediately upon phone or written request. Upon examination by OMEGA, if the unit is found to be defective, it will be repaired or replaced at no charge. OMEGA's WARRANTY does not apply to defects resulting from any action of the purchaser, including but not limited to mishandling, improper interfacing, operation outside of design limits, improper repair, or unauthorized modification. This WARRANTY is VOID if the unit shows evidence of having been tampered with or shows evidence of having been damaged as a result of excessive corrosion; or current, heat, moisture or vibration; improper specification; misapplication; misuse or other operating conditions outside of OMEGA's control. Components in which wear is not warranted, include but are not limited to contact points, fuses, and triacs.

**OMEGA is pleased to offer suggestions on the use of its various products. However, OMEGA neither assumes responsibility for any omissions or errors nor assumes liability for any damages that result from the use of its products in accordance with information provided by OMEGA, either verbal or written. OMEGA warrants only that the parts manufactured by the company will be as specified and free of defects. OMEGA MAKES NO OTHER WARRANTIES OR REPRESENTATIONS OF ANY KIND WHATSOEVER, EXPRESSED OR IMPLIED, EXCEPT THAT OF TITLE, AND ALL IMPLIED WARRANTIES INCLUDING ANY WARRANTY OF MERCHANTABILITY AND FITNESS FOR A PARTICULAR PURPOSE ARE HEREBY DISCLAIMED. LIMITATION OF LIABILITY: The remedies of purchaser set forth herein are exclusive, and the total liability of OMEGA with respect to this order, whether based on contract, warranty, negligence, indemnification, strict liability or otherwise, shall not exceed the purchase price of the component upon which liability is based. In no event shall OMEGA be liable for consequential, incidental or special damages.**

CONDITIONS: Equipment sold by OMEGA is not intended to be used, nor shall it be used: (1) as a "Basic Component" under 10 CFR 21 (NRC), used in or with any nuclear installation or activity; or (2) in medical applications or used on humans. Should any Product(s) be used in or with any nuclear installation or activity, medical application, used on humans, or misused in any way, OMEGA assumes no responsibility as set forth in our basic WARRANTY/DISCLAIMER language, and, additionally, purchaser will indemnify OMEGA and hold OMEGA harmless from any liability or damage whatsoever arising out of the use of the Product(s) in such a manner.

## RETURN REQUESTS/INQUIRIES

Direct all warranty and repair requests/inquiries to the OMEGA Customer Service Department. BEFORE RETURNING ANY PRODUCT(S) TO OMEGA, PURCHASER MUST OBTAIN AN AUTHORIZED RETURN (AR) NUMBER FROM OMEGA'S CUSTOMER SERVICE DEPARTMENT (IN ORDER TO AVOID PROCESSING DELAYS). The assigned AR number should then be marked on the outside of the return package and on any correspondence.

The purchaser is responsible for shipping charges, freight, insurance and proper packaging to prevent breakage in transit.

FOR **WARRANTY** RETURNS, please have the following information available BEFORE contacting OMEGA:

1. Purchase Order number under which the product was PURCHASED,
2. Model and serial number of the product under warranty, and
3. Repair instructions and/or specific problems relative to the product.

FOR **NON-WARRANTY** REPAIRS, consult OMEGA for current repair charges. Have the following information available BEFORE contacting OMEGA:

1. Purchase Order number to cover the COST of the repair,
2. Model and serial number of the product, and
3. Repair instructions and/or specific problems relative to the product.

OMEGA's policy is to make running changes, not model changes, whenever an improvement is possible. This affords our customers the latest in technology and engineering.

OMEGA is a registered trademark of OMEGA ENGINEERING, INC.

© Copyright 2012 OMEGA ENGINEERING, INC. All rights reserved. This document may not be copied, photocopied, reproduced, translated, or reduced to any electronic medium or machine-readable form, in whole or in part, without the prior written consent of OMEGA ENGINEERING, INC.

# Where Do I Find Everything I Need for Process Measurement and Control?

**OMEGA...Of Course!**

***Shop online at [omega.com](http://omega.com)<sup>SM</sup>***

## **TEMPERATURE**

- ☑ Thermocouple, RTD & Thermistor Probes, Connectors, Panels & Assemblies
- ☑ Wire: Thermocouple, RTD & Thermistor
- ☑ Calibrators & Ice Point References
- ☑ Recorders, Controllers & Process Monitors
- ☑ Infrared Pyrometers

## **PRESSURE, STRAIN AND FORCE**

- ☑ Transducers & Strain Gages
- ☑ Load Cells & Pressure Gages
- ☑ Displacement Transducers
- ☑ Instrumentation & Accessories

## **FLOW/LEVEL**

- ☑ Rotameters, Gas Mass Flowmeters & Flow Computers
- ☑ Air Velocity Indicators
- ☑ Turbine/Paddlewheel Systems
- ☑ Totalizers & Batch Controllers

## **pH/CONDUCTIVITY**

- ☑ pH Electrodes, Testers & Accessories
- ☑ Benchtop/Laboratory Meters
- ☑ Controllers, Calibrators, Simulators & Pumps
- ☑ Industrial pH & Conductivity Equipment

## **DATA ACQUISITION**

- ☑ Data Acquisition & Engineering Software
- ☑ Communications-Based Acquisition Systems
- ☑ Plug-in Cards for Apple, IBM & Compatibles
- ☑ Data Logging Systems
- ☑ Recorders, Printers & Plotters

## **HEATERS**

- ☑ Heating Cable
- ☑ Cartridge & Strip Heaters
- ☑ Immersion & Band Heaters
- ☑ Flexible Heaters
- ☑ Laboratory Heaters

## **ENVIRONMENTAL MONITORING AND CONTROL**

- ☑ Metering & Control Instrumentation
- ☑ Refractometers
- ☑ Pumps & Tubing
- ☑ Air, Soil & Water Monitors
- ☑ Industrial Water & Wastewater Treatment
- ☑ pH, Conductivity & Dissolved Oxygen Instruments