

1 YEAR
WARRANTY

MADE IN
USA



User's Guide

Shop online at

omega.com[®]

Ω OMEGA[®]

www.omega.com

e-mail: info@omega.com

ISO 9001

CERTIFIED
CORPORATE QUALITY

STAMFORD, CT

ISO 9002

CERTIFIED
CORPORATE QUALITY

MANCHESTER, UK



CT7300 SERIES **2 Pen Circle Chart Recorder**



OMEGAnet® Online Service www.omega.com	Internet e-mail info@omega.com
---	--

Servicing North America:

USA:
ISO 9001 Certified

One Omega Drive, Box 4047
Stamford CT 06907-0047
Tel: (203) 359-1660 FAX: (203) 359-7700
e-mail: info@omega.com

Canada:

976 Bergar
Laval (Quebec) H7L 5A1, Canada
Tel: (514) 856-6928 FAX: (514) 856-6886
e-mail: info@omega.ca

For immediate technical or application assistance:

USA and Canada: Sales Service: 1-800-826-6342 / 1-800-TC-OMEGA®
Customer Service: 1-800-622-2378 / 1-800-622-BEST®
Engineering Service: 1-800-872-9436 / 1-800-USA-WHEN®
TELEX: 996404 EASYLINK: 62968934 CABLE: OMEGA

Mexico: En Español: (001) 203-359-7803 e-mail: espanol@omega.com
FAX: (001) 203-359-7807 info@omega.com.mx

Servicing Europe:

Benelux: Postbus 8034, 1180 LA Amstelveen, The Netherlands
Tel: +31 (0)20 3472121 FAX: +31 (0)20 6434643
Toll Free in Benelux: 0800 0993344
e-mail: sales@omegaeng.nl

Czech Republic: Frystatska 184/46, 733 01 Karviná, Czech Republic
Tel: +420 (0)59 6311899 FAX: +420 (0)59 6311114
Toll Free: 0800-1-66342 e-mail: info@omegashop.cz

France: 11, rue Jacques Cartier, 78280 Guyancourt, France
Tel: +33 (0)1 61 37 29 00 FAX: +33 (0)1 30 57 54 27
Toll Free in France: 0800 466 342
e-mail: sales@omega.fr

Germany/Austria: Daimlerstrasse 26, D-75392 Deckenpfronn, Germany
Tel: +49 (0)7056 9398-0 FAX: +49 (0)7056 9398-29
Toll Free in Germany: 0800 639 7678
e-mail: info@omega.de

United Kingdom: ISO 9002 Certified One Omega Drive, River Bend Technology Centre
Northbank, Irlam, Manchester
M44 5BD United Kingdom
Tel: +44 (0)161 777 6611 FAX: +44 (0)161 777 6622
Toll Free in United Kingdom: 0800-488-488
e-mail: sales@omega.co.uk

It is the policy of OMEGA to comply with all worldwide safety and EMC/EMI regulations that apply. OMEGA is constantly pursuing certification of its products to the European New Approach Directives. OMEGA will add the CE mark to every appropriate device upon certification.

The information contained in this document is believed to be correct, but OMEGA Engineering, Inc. accepts no liability for any errors it contains, and reserves the right to alter specifications without notice.

WARNING: These products are not designed for use in, and should not be used for, human applications.

Contents CT7300 Recorder

	Page Number
Chapter 1 Overview	
1-1 General	1
1-2 Ordering Code	2
Chapter 2 Installation	
2-1 Unpacking	3
2-2 Mounting	3
2-3 Case Location	4
2-4 Wiring Precautions	5
2-5 PowerWiring	6
2-6 Sensor Installation Guidelines	7
2-7 Thermocouple Input Wiring	8
2-8 RTD Input Wiring	9
2-9 Linear DC Input Wiring	9
2-10 Alarm Relay Wiring	9
2-11 Changing the Chart	10
2-12 Marking Systems	10
2-13 Replacement of Pen	11
2-14 Battery Backup	12
Chapter 3 Programming	
3-1 Recorder Setup	13
3-2 Alarm Settings	14
Chapter 4 Calibration	
4-1 Pen Arm Calibration	15
Chapter 5 Specifications	17
Chapter 6 Dimensions / Troubleshooting	19

Chapter 1 Overview

1-1 General

The CT7300 is a microprocessor based circle chart recorder. Programmable alarm options combined with "ease of setup" provide the flexibility required for multiple recording applications.

The Ink style CT7300 is the first recorder to "self document" setup configuration during initial setup and can operate using standard 10 inch charts. The battery backup provides up to 48 hours of recording in the event of power loss, thereby providing an additional degree of protection for customer processes. A green LED indicates battery condition, see section 2-14. (Page 15)

The unit is powered by 115/230VAC, 50/60Hz. Programmable inputs for thermocouple types J, K, T, R, B and S as well as 4-20mA or 0-5VDC are standard. Optional alarm relays are available and programmable for low, high or band operation. A green LED indicates unit is recording.

A unique setup chart provides the user with an "on the spot" manual. This setup chart will also self document the current setup for quick review by an operator. High accuracy, maximum flexibility, fast response and a simple user interface are the main benefits of the CT7300 recorder.

Warning Symbol

This  Symbol calls attention to an operating procedure, practice, or the like, which, if not correctly performed or adhered to, could result in personal injury or damage to or destruction of part or all of the product and system. Do NOT proceed beyond a warning symbol until the indicated conditions are fully understood and met.

Use the Manual

- Installers Read Chapter 1, 2, 3
- System Read all chapters

1-2 CT7300 Ordering Code

Model CT 7310 Dual Pen Recorder

Model CT 7311 Dual Pen Recorder W/ Alarm Relay Pen 1

Model CT 7312 Dual Pen Recorder W/ Alarm Relay Pen 1 & 2

All Recorders are provided with mounting brackets, battery
And 1 box of charts

Spare Parts

Replacement Red Pens P/N 7300-Red (6 / package)

Replacement Green Pens P/N 7300-Green (6 / package)

Charts standard P/N CT7000C-100-24 (0/100, 24hr)
100 charts / box

Chapter 2 Installation



Dangerous voltages capable of causing death are sometimes present when wiring the instrument. Before installation or beginning any troubleshooting procedures the power to all equipment must be switched off and isolated. Units suspected of being at fault must be disconnected and removed to a properly equipped workshop for testing and repair. Component replacement and internal adjustments must be made by qualified personnel only.

This recorder operates on 115 or 230 (50-60Hz), be sure line voltage OFF before connecting recorder.



This symbol represents Earth Ground connection point.



To minimize the possibility of fire or shock hazards, do not expose this instrument to rain or excessive moisture.



Do not use this instrument in areas under hazardous conditions such as excessive shock, vibration, dirt, moisture, corrosive gases or oil. The ambient temperature of the areas should not exceed the maximum rating specified in Chapter 5.

2-1 Unpacking

Upon receipt of the shipment remove the unit from the carton and inspect the unit for shipping damage.

If any damage due to transit, report and claim with the carrier. Write down the model number, serial number, and date code for future reference when corresponding with our service center. The serial number (S/N) and date code (D/C) are labeled on the box and the bottom side of the recorder. Make sure that all items are accounted for:

- 1: Battery (for battery backup)
- 2: Ferrite Core
- 3: User's Guide
- 4: Chart Recorder

2-2 Mounting

The Chart Recorder can be mounted inside a panel.

Install both mounting clamps and insert the case into panel cutout.
The Panel cut out is 32.3 x 32.3 cm (12.72 x 12.72 in.)

2-3 Case Location

Upon unpacking, find a suitable location to mount the recorder before wiring power to the unit. After the recorder has been connected to the main AC power supply, install the 9VDC battery in it's holder.

Select a location that is well lighted, free from dust, dirt or corrosive fumes. The instrument should not be located near any sources of heat or be subject of sudden or extreme temperature changes. It should be mounted on a rigid support that is not subject of vibration. Refer to figure 6.1 for recorder case dimensions.

2-4 Wiring Precautions

- Before wiring, verify the label for correct model number and options. Switch off the power when checking.
- Care must be taken to ensure that maximum voltage rating specified on the label are not exceeded.
- It is recommended that power of these units to be protected by fuses or circuit breakers rated at the minimum value possible.
- All units should be installed inside a suitably grounded metal enclosure to prevent live parts being accessible from human hands and metal
- All wiring must conform to appropriate standards of good practice and local codes and regulations. Wiring must be suitable for maximum voltage, current, and temperature rating of the system.
- Take care not to over-tighten the terminal screws.
- Unused control terminals should not be used as jumper points as they may be internally connected, causing damage to the unit.
- Verify that the ratings of the output devices and the inputs as specified in Chapter 5 are not exceeded.
- Electric power in industrial environments contains a certain amount of noise in the form of transient voltage and spikes. This electrical noise can enter and adversely affect the operation of microprocessor-based controls. For this reason we strongly recommend the use of shielded thermocouple extension wire which connects the sensor to the unit. This wire is a twisted-pair construction with foil wrap and drain wire. The drain wire is to be attached to earth ground at the sensor end only.

2-5 Power Wiring

The unit is supplied to operate at 115/230VAC 50/60Hz. Check that the installation voltage corresponds with the power rating indicated on the product label before connecting power to the unit.

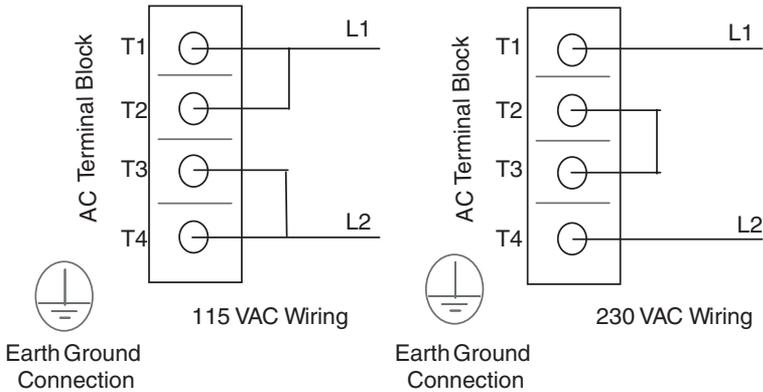

Figure 2.1
Power Supply Connections

The recorder uses AC power when it is operating normally. The battery back-up option will allow the recorder to operate for approximately 48 hours in case of a power loss. AC input can be fused with a 250VAC, .5 Amp fuse.

In order to connect the recorder to the main AC power, you must first gain access to the microprocessor PC board that is mounted to the back of the chart plate. Your recorder will have a hinged chart plate held in place by two (2) screws located on the right hand side of the chart plate. Remove these two screws and open the hinged chart plate.

The AC power connections are made to the 4 position terminal block located on back side of plate. All AC and ground wires must be a minimum of 16 AWG. Refer to Figure 2.1 for proper connection to the main AC power. Earth Ground must be connected at ground lug provided. See Figure 2.1



This equipment is designed for installation in an enclosure which provides adequate protection against electric shock. Grounding of this Recorder must meet national and local codes. Ground wire should be Color coded GREEN or GREEN with a YELLOW strip.

Local requirements regarding electrical installation should be rigidly observed. Consideration should be given to prevent unauthorized persons access to the power terminals.

2-6 Sensor Installation Guidelines

Proper sensor installation can eliminate many problems in a control system. The probe should be placed so that it can detect any temperature change with minimal thermal lag. In a process that requires fairly constant heat output, the probe should be placed closed to the heater. In a process where the heat demand is variable, the probe should be closed to the work area. Some experiments with probe location are often required to find this optimum position.

Proper sensor type is also a very important factor to obtain precise measurements. The sensor must have the correct temperature range to meet the process requirements. In special processes the sensor might need to have different requirements such as leak-proof, anti-vibration, antiseptic, etc.

Standard thermocouple sensor limits of error are ± 4 degrees F (± 2 degrees C) or 0.75% of sensed temperature plus drift caused by improper protection or an over-temperature occurrence. This error is far greater than controller error and cannot be corrected at the sensor except by proper selection and replacement.

In order to connect the probe input device to the recorder, you must first gain access to the microprocessor PC board that is mounted to the back of the chart plate.

A ferrite core has been included to provide additional protection against electrical RF Noise sensor signal wires may pick up. See drawing below for correct installation of this device.

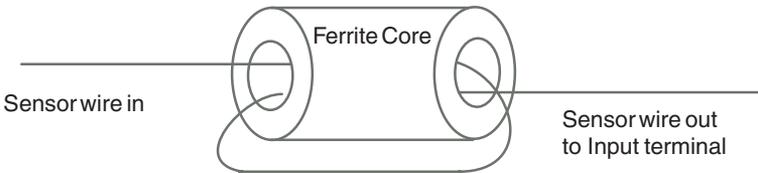

Figure 2.2



CAUTION! DO NOT TOUCH the terminals of the transformer while the recorder is connected to the main AC power supply. To avoid the risk of possible electric shock, unplug or disconnect the recorder from

the main power supply before attempting to open the recorder. If the recorder is installed with the battery back-up option, disconnect the 9 Volt battery to avoid damaging the recorder and draining the battery.

Your recorder will have a hinged chart plate held in place by two (2) screws located on the right hand side of the chart plate. Remove these two screws and open the hinged chart plate. If you are not sure how to access the back of the chart plate, please contact OMEGA Engineering before continuing.

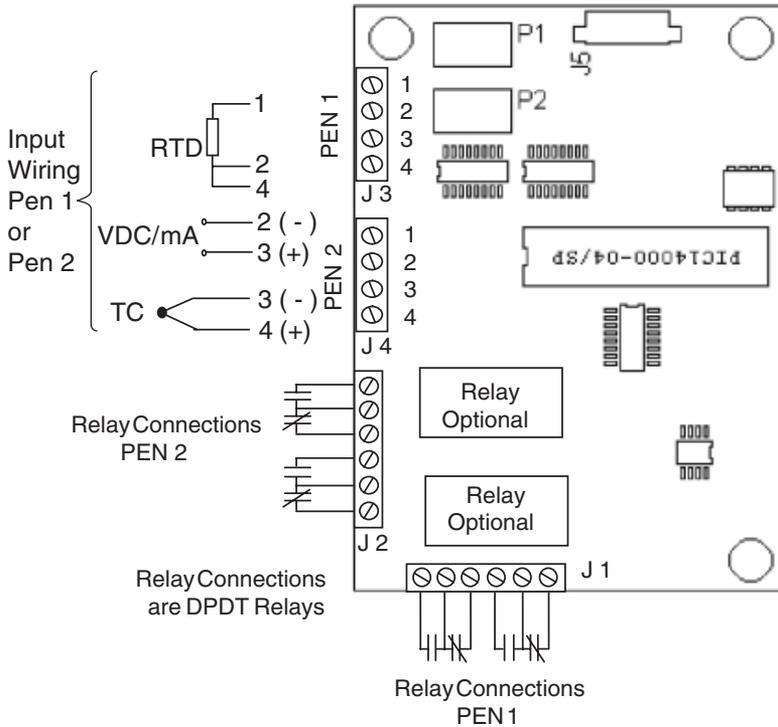

Figure 2.3 Input/Relay wiring PCB layout

2-7 Thermocouple Input Wiring

Thermocouple input connections are shown in Figure 2.3. The correct type of thermocouple extension lead-wire or compensating cable must be used for the entire distance between the unit and the thermocouple, ensuring that the correct polarity is observed throughout. Splices in the cable should be avoided, if possible. A ferrite core is supplied with the CT7300 recorder to provide additional protection against RF noise. Input wiring should be wrapped around the core before wiring to the recorder inputs.

If the length of thermocouple plus the extension wire is too long, it may affect the temperature measurement. A 400 ohms K type or a 500 ohms J type thermocouple lead resistance will produce approximately 1 degree C temperature error.

2-8 RTD Input Wiring

RTD connection are shown in Figure 2.3, with the compensating lead connected to terminal 4. For two-wire RTD inputs, terminals 2 and 4 should be linked. The three-wire RTD offers the capability of lead resistance compensation provided that the three leads are of same gauge and equal length.

Two-wire RTD should be avoided, if possible, for the purpose of accuracy. A 0.4 ohm lead resistance of a two-wire RTD will produce 1 degree C temperature error.

2-9 Linear DC Input Wiring

DC linear voltage and linear current connections are also shown in Figure 2.3.

2-10 Alarm Relay

If your recorder has the optional relay contacts installed, then terminal blocks J1 and J2 have been provided for connection to the relay on the microprocessor PC board of the recorder. Refer to Figure 2.3 for the location of J1 and J2 on the microprocessor PC board.



CAUTION! DO NOT TOUCH the terminals of the transformer while the recorder is connected to the main AC power supply. To avoid the risk of possible electric shock, unplug or disconnect the recorder from the main power supply before attempting to access the terminals of the relay. If the recorder is installed with the battery back-up option, disconnect the 9 Volt battery to avoid damaging the recorder and draining the battery.

Your recorder has a hinged chart plate held in place by two (2) screws located on the right hand side of the chart plate. Remove these two screws and open the hinged chart plate.

The relays are rated for the following maximum Values:

2.0 AMPS at 25VDC

1.0 AMP at 120VAC

Warning: Damage to the recorder may result if the ratings for the relays are exceeded.

2-11 Changing the Chart

Press and release the CHANGECHART key (3 on Figure 3.1). The pen(s) will move to the left of the chart and green LED will flash rapidly. Wait until the pen(s) stops above outer ring AND green LED goes to on steady. Unscrew the chart "hub" knob at the center of the chart. Remove the old chart paper and position the new one so that the correct time line coincides with the time line groove on the chart plate. Refer to Figure 2.4 for the location of the time line groove.

Re-attach the chart "hub" knob and screw securely (by hand) against the chart. Press and release the CHANGECHART key (3). The pen will move to the outer ring, green LED remains on, then pauses. If alarms are enabled pen(s) will then move to current alarm setpoints. For information to set these setpoints please see Chapter 3.

If alarms are not enabled after pausing at outer ring, pens will go to current recording value.

Check to make sure that the pen(s) are marking on the chart paper. If it is not, then carefully adjust the pen arm to establish contact with the paper.

2-12 Marking Systems

This type of pen consists of a self contained ink reservoir with a porous plastic stylus which is snapped around the outer edge of the metal pen arm.

A pen cap is provided to extend the life of the ink pen during shipping or when the recorder is not in service. To remove the pen cap, gently lift the pen arm away from the chart paper. Remove the black plastic pen cap to expose the fiber tip of the ink pen and gently place the pen back onto the chart paper. Do not let the pen arm "snap" back onto the chart paper. This will flatten the fiber tip of the pen and will no longer give you a fine line marking on the chart paper. Place the pen cap in a safe place for future use.

If the stylus does not touch the chart, adjustment can be made by slightly bending the metal pen arm in the center towards the chart paper. Do not use more pressure than is necessary to create a fine line marking on the chart paper. Note: As the pen ink supply runs out, the pen color will become lighter. This indicates that the pen should be replaced.

2-13 Replacement of Pen

Recorders that are equipped with fiber tipped cartridge pens are colored coded RED for pen 1 and GREEN for pen 2.

The pen cartridge is securely fastened to the metal pen arm using a special "U" clip tab.

For ease of replacement, it is suggested that the two (2) screws that hold the pen arm be loosened and the pen cartridge and metal pen arm be removed as an assembly. Refer to Figure 2.5 for the location of the pen arm screws. Unsnap the plastic "U" clip tab of the pen cartridge from the metal pen arm, remove and discard the old pen cartridge. Replace the new cartridge by opening the hinge and snapping it securely around the metal pen arm. Refer to Figure 2.4 for pen cartridge replacement.

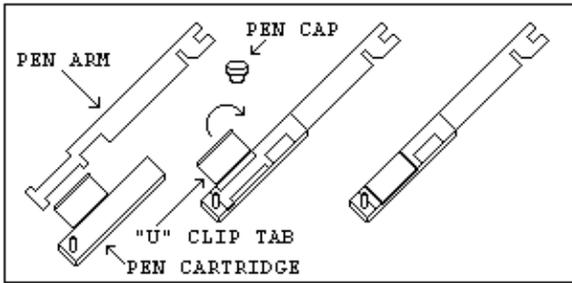

Figure 2.4 Pen Replacement

2-14 Battery Backup

The 9 volt battery backup option allows the recorder to operate normally for approximately 48 hours in the event of a power failure.

The green LED provides an indication of battery condition (when battery backup option is installed on recorder).

If green LED is on continuous, battery voltage is acceptable.

If green LED is flashing rapidly, battery voltage is below 7.5 VDC, indicating that the battery should be replaced.

The battery strap and battery holder are located on the front of the chart plate (refer to Figure 2.5). In order to change the battery, you must open the recorder case door. Note: Use only NEW 9 volt alkaline replacement batteries.

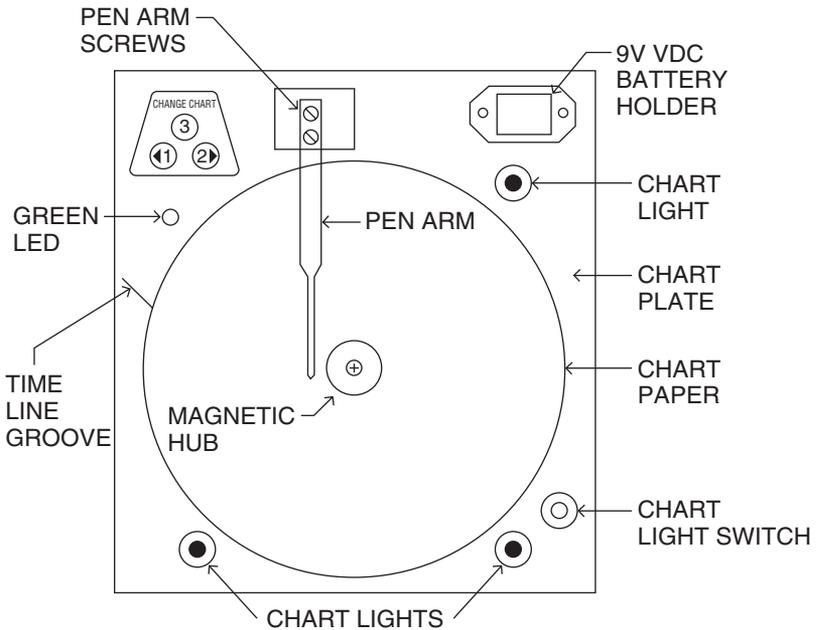

Figure 2.5 Recorder Plate Layout/Battery Installation

Chapter 3 Programming

3-1 Recorder Setup

In order to configure the recorder, you will need the recorder SET-UP CHART. These charts contain the configuration categories of the recorder (Probe Input, Inner Chart Values, Outer Chart Values, Units, Chart Rotation, Input Averaging and Relay Options). Place the SET-UP CHART onto the recorder. This setup chart could be left on the recorder behind the normal recording chart for easy access or behind the platen assembly.

1. Place SETUPCHART on recorder.
2. Press and release CHANGECHART key (3), pens will begin to move off scale and green LED will flash rapidly. Wait until pens are off scale AND Green LED goes to on steady.
3. Press and hold LEFT arrow key (1) until green LED turns off. Then release key. Pens will move to outer ring. Wait for green LED to flash slowly. (.8sec on/.8sec off) Note; Green LED will continue to flash slowly during setup mode.
4. Green Pen will move to outer ring of SETUPCHART first. Then Red pen will then move to outer ring. Please note green pen setup selections allowed are only for categories Input Probe and Relay selections.
5. Loosen chart knob and rotate chart to position Red pen in middle of the STARTCIRCLE
6. Tighten chart knob. Press and release the CHANGECHART key (3). Red Pen will move to first selection category to current value. Position red pen to desired selection using LEFT (1) and RIGHT (2) keys.
7. Press and release the CHANGECHART key (3) to store selection. Green Pen will now advance to current selection. Position Green pen to desired selection using LEFT (1) and RIGHT(2) arrow keys. Press and release CHANGECHART key (3) to store selection. Green pen will now move to outer ring. Green pen will remain at outer ring until Relay category.
8. Repeat selection process in EACH category until all categories are selected. Green pen shares program information selected by Red pen.
9. After last category (Relay) is selected, press and release CHANGE CHART key (3). Pens will move off scale. Green LED will flash rapidly. Wait until Green LED goes to on steady. Setup is now complete.
10. Remove/ store SETUPCHART. Install actual recording chart to be used.
11. Press and release CHANGECHART(3) key. Pens will move to 100% ring, then to relay setpoints , if programmed. Then to actual recording values.

Figure 3.1
Keypad Layout

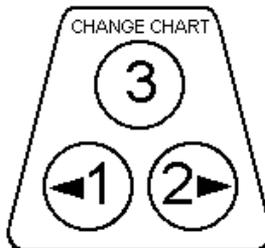

3-2 Alarm Settings

Alarm setpoint values are selected by positioning the pen to the actual value on the recording chart. Alarm settings can be selected or viewed after CHARTCHANGE, recorder setup or during initial power up. To set the alarm setpoint during normal recording operation, complete the following steps.

Press and release the CHANGECHART key (3 on Figure 3.1). Wait until pen(s) moves off scale and LED status changes from flashing to steady. Press and release the CHANGECHART (3 on Figure 3.1) again, the pen will begin to move back onto the chart briefly stopping at (or close to) the outer most graduation of the chart. Green LED remains on steady during this time.

Single Alarm Setting

After the above operation is complete, the pen(s) arm will move to the current alarm setpoint position on the chart (one pen at a time). The green LED will go out, during this time the alarm setpoint (for each pen) can be adjusted using the LEFT arrow (1) or the RIGHTarrow (2) keys on the keypad. Once the alarm setpoint is set, wait for the green LED will turn on and the pen arm will move to indicate the probe's temperature and the unit will begin normal recording operation.

Band Alarm Setting

When programming the recorder for band alarm operation, the pen(s) will move to the first band setpoint on the chart. The green LED will go out. The alarm band 1 setpoint can now be adjusted using the LEFT arrow (1) or the RIGHTarrow (2) keys, once set, wait for the green LED to turn on. The active pen will then move to the second band alarm setpoint. The green LED will go out. The alarm band 2 can now be adjusted. When pen(s) alarm setpoints adjustments are completed, wait for the green LED to turn on and the pen arm will move to indicate the probe's temperature and the unit will begin normal recording operation.

The "Change Chart" key is the "RESET" when the recorder is programmed for latching alarm operation. Please note relay will only reset if alarm condition has been cleared.

Chapter 4 Calibration

4-1 Pen Arm Calibration (Zero and Span)

Pen calibration is a two point calibration. To check and/or adjust the recording pen(s) calibration to the inner and outer graduations of the chart, Perform the following.

1. Remove power to instrument. If unit has battery option also remove battery.
2. With all power removed, press and hold the CHANGECHART key (3). While holding the CHANGECHART key(3), re-apply power. Release key upon applying power, either AC or battery which ever is convenient.
3. The pens will move off scale, LED will flash rapidly. Green LED will then go to steady on.
4. The green pen will then move to 100% ring. Adjust green pen using LEFT (1) and RIGHT(2) keys to position pen on 100% ring, then Wait.
5. Red pen will then move to 100% ring. Adjust this pen to 100% ring, using LEFT (1) and RIGHT(2) keys, then wait.
6. Red pen will then move to 0% ring. Adjust pen using LEFT (1) and RIGHT(2) keys, then wait. Pen will then move full upscale.
7. Green pen will move to 0% ring. Adjust pen to 0%, using LEFT (1) and RIGHT(2) keys, then wait. Green pen will now travel full upscale.
8. Pen calibration is now complete.

If unit has alarms enabled pens will now go to current alarm settings. See Section 3.2. Then to actual recording value.

If no alarms are enabled pens will then go directly to actual recording values.

Each time the chart paper or fiber tip pen cartridge is changed, you should make sure that each pen stops at the inner and outer most temperature graduation of the chart paper. Otherwise, this pen offset can cause the unit to record an incorrect temperature on the chart.

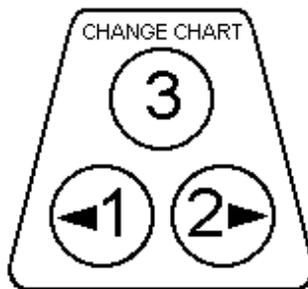

Figure 4.1 Keypad Layout

4-2 Probe Offset Adjustment (pen offset)

This recorder has been accurately calibrated at the factory. Before making any adjustments, this instrument should be in service for 24 hours.

Thereafter if any adjustment is required, perform the following procedure.

1. Place a Certified Test Thermometer(s) alongside the recorder's sensor probe(s) in a monitored controlled condition.
2. Once the temperature has leveled out, compare the position of the pen(s) on the recorder to the test thermometer's reading, also compare the Certified Test Thermometer's reading to the second pen of the recorder.
3. For two (2) pen recorders, you must first select the pen that you wish to calibrate. This is done by pressing the LEFT (1) arrow key to select the Red pen or the RIGHT (2) arrow key to select the Green pen. The appropriate arrow key must be held down for approximately five (5) seconds until the green LED goes out. Once the green LED goes out, release the key. The green LED will begin to flash steady. Adjust the selected pen to the desired value. This is done by using the LEFT (1) or RIGHT (2) arrow keys. Once the corrected value is obtained, wait. Green LED will go to on steady, indicating return to normal recording mode.

After temperature calibration check is complete, the recorder will return to normal recording mode within 5 seconds of no further key depression.

Chapter 5 Specifications

Power

Line Voltage: 115/230VAC, 50/60Hz
Power Consumption: 15 VA maximum

Input

Thermocouple (T/C): Type J, K, T, R, B, S,
RTD: PT 100 ohm RTD (385 curve)
Linear: 4-20 mA, 0-5 VDC
Range: See Table 5-1
Common Mode Rejection: > 120dB at 60 Hz
Cold Junction Accuracy: $\pm 0.2^{\circ}\text{C}$ @ 25°C ambient
Cold Junction Error: $\pm 0.2^{\circ}\text{C}$ @ 25°C ambient
Ambient Error: $\pm 0.01\%$ span/ $^{\circ}\text{C}$ from 25°C ambient
Isolation: Inputs isolated from outputs

Recording

Chart Size: 10°
Recording Accuracy: $\pm 0.5\%$ of span (100 division span)
Sensor Break: Full scale Pen < 10 seconds
Chart Speed: Programmable for 4, 8, 12, 24, 48, 72, 168 hour rotation
Input Filtering: Programmable up to 120 seconds
Battery Backup: 9VDC Provides up to 48 hours of recording

Options

Relay: DPDT, 1.0 Amps @ 120 VAC resistive
Relay Program: Process, Band, Non-latching, Latching
Error Protection: De-energized during sensor break
Hysteresis: Set at 2 units, activation is safe sided

Environmental and Physical

Operating Temperature: 0 to 60°C (32 to 140°F)
Storage Temperature: -40 to 65°C (-40 to 149°F)
Humidity: 0-90% RH (non-condensing)
Agency Approval: UL /CUL
Installation Category: II
Pollution Degree: 2
Altitude: 2000 meters
Vibration: 0.3 to 100Hz @ 0.2g
Mounting: ± 20 degrees of vertical
 ± 10 degrees of horizontal
Moldings: Fire retardant Noryl w/acrylic window
Panel Rating: Nema 12X std (Nema 4 optional)
Dimensions: 35.5 H x 35.5 W x 9.6 D cm (14.00 H x 14.00 W x 3.80 D in.)
Panel Cutout: Industry Standard 32.3 x 32.3 cm (12.72 x 12.72 in.)
Weight: 7 pounds maximum

5-1 Input Range Table:

Type	Range
J	-130°C/760°C (-202°F/1400°F)
K	-130°C/1370°C (-202°F/2498°F)
T	-200°C/400°C (-328°F/752°F)
B	100°C/1824°C (212°F/3315°F)
R	0°C/1650°C (32°F/3002°F)
S	0°C/1649°C (32°F/3000°F)
PT100 (DIN)	-210°C/440°C (-346°F/824°F)
MA	4mA - 20mA
V	0V - 5VDC

Table 5-1 Input Characteristics

Lower Chart Range Selection:

Programmable from - 999 to 9999 Units

Upper Chart Range Selection:

Programmable from - 999 to 9999 Units

Note: Recommended minimum chart span for thermocouple inputs is 100 units.

Chapter 6 Case Dimensions

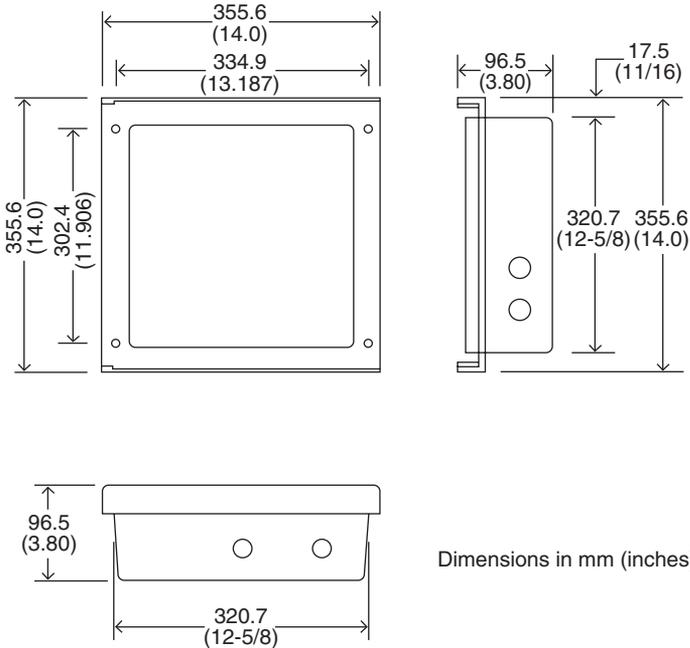

Figure 6.1 Case Dimensions

LED LIGHT SEQUENCE GUIDE

GREEN LED Troubleshooting Guide

- 1.) LED on steady and pen(s) within chart range, unit is recording normally.
- 2.) LED on steady and pen(s) above 100% ring indicates unit is in "CHART CHANGE" mode. Action: Press and release "CHARTCHANGE" key to return to normal recording mode.
- 3.) LED flashing RAPIDLY and pen(s) within chart range indicates battery voltage is low. Action: Replace battery. (If option is applicable)
- 4.) LED flashing RAPIDLY and pen(s) at 0 or 100% ring indicates that input sensor(s) are in a break condition.
Action: Check or replace sensor, validate setup information for sensor.
- 5.) LED flashing slowly (.8 sec.. On/ .8 sec. off) unit in setup mode.
Action: Complete setup procedure of recorder.
- 6.) LED not on indicates no power to unit.
Action: Check to see if AC present on power terminals. If battery option exists check and/or replace battery.



WARRANTY/DISCLAIMER

OMEGA ENGINEERING, INC. warrants this unit to be free of defects in materials and workmanship for a period of **12 months** from date of purchase. OMEGA's Warranty adds an additional one (1) month grace period to the normal **one (1) year product warranty** to cover handling and shipping time. This ensures that OMEGA's customers receive maximum coverage on each product.

If the unit malfunctions, it must be returned to the factory for evaluation. OMEGA's Customer Service Department will issue an Authorized Return (AR) number immediately upon phone or written request. Upon examination by OMEGA, if the unit is found to be defective, it will be repaired or replaced at no charge. OMEGA's WARRANTY does not apply to defects resulting from any action of the purchaser, including but not limited to mishandling, improper interfacing, operation outside of design limits, improper repair, or unauthorized modification. This WARRANTY is VOID if the unit shows evidence of having been tampered with or shows evidence of having been damaged as a result of excessive corrosion; or current, heat, moisture or vibration; improper specification; misapplication; misuse or other operating conditions outside of OMEGA's control. Components which wear are not warranted, including but not limited to contact points, fuses, and triacs.

OMEGA is pleased to offer suggestions on the use of its various products. However, OMEGA neither assumes responsibility for any omissions or errors nor assumes liability for any damages that result from the use of its products in accordance with information provided by OMEGA, either verbal or written. OMEGA warrants only that the parts manufactured by it will be as specified and free of defects. OMEGA MAKES NO OTHER WARRANTIES OR REPRESENTATIONS OF ANY KIND WHATSOEVER, EXPRESS OR IMPLIED, EXCEPT THAT OF TITLE, AND ALL IMPLIED WARRANTIES INCLUDING ANY WARRANTY OF MERCHANTABILITY AND FITNESS FOR A PARTICULAR PURPOSE ARE HEREBY DISCLAIMED. LIMITATION OF LIABILITY: The remedies of purchaser set forth herein are exclusive, and the total liability of OMEGA with respect to this order, whether based on contract, warranty, negligence, indemnification, strict liability or otherwise, shall not exceed the purchase price of the component upon which liability is based. In no event shall OMEGA be liable for consequential, incidental or special damages.

CONDITIONS: Equipment sold by OMEGA is not intended to be used, nor shall it be used: (1) as a "Basic Component" under 10 CFR 21 (NRC), used in or with any nuclear installation or activity; or (2) in medical applications or used on humans. Should any Product(s) be used in or with any nuclear installation or activity, medical application, used on humans, or misused in any way, OMEGA assumes no responsibility as set forth in our basic WARRANTY/DISCLAIMER language, and, additionally, purchaser will indemnify OMEGA and hold OMEGA harmless from any liability or damage whatsoever arising out of the use of the Product(s) in such a manner.

RETURN REQUESTS/INQUIRIES

Direct all warranty and repair requests/inquiries to the OMEGA Customer Service Department. **BEFORE RETURNING ANY PRODUCT(S) TO OMEGA, PURCHASER MUST OBTAIN AN AUTHORIZED RETURN (AR) NUMBER FROM OMEGA'S CUSTOMER SERVICE DEPARTMENT (IN ORDER TO AVOID PROCESSING DELAYS).** The assigned AR number should then be marked on the outside of the return package and on any correspondence.

The purchaser is responsible for shipping charges, freight, insurance and proper packaging to prevent breakage in transit.

FOR **WARRANTY** RETURNS, please have the following information available BEFORE contacting OMEGA:

1. Purchase Order number under which the product was PURCHASED,
2. Model and serial number of the product under warranty, and
3. Repair instructions and/or specific problems relative to the product.

FOR **NON-WARRANTY** REPAIRS, consult OMEGA for current repair charges. Have the following information available BEFORE contacting OMEGA:

1. Purchase Order number to cover the COST of the repair,
2. Model and serial number of the product, and
3. Repair instructions and/or specific problems relative to the product.

OMEGA's policy is to make running changes, not model changes, whenever an improvement is possible. This affords our customers the latest in technology and engineering.

OMEGA is a registered trademark of OMEGA ENGINEERING, INC.

© Copyright 2003 OMEGA ENGINEERING, INC. All rights reserved. This document may not be copied, photocopied, reproduced, translated, or reduced to any electronic medium or machine-readable form, in whole or in part, without the prior written consent of OMEGA ENGINEERING, INC.

Where Do I Find Everything I Need for Process Measurement and Control? **OMEGA...Of Course!**

Shop online at www.omega.com

TEMPERATURE

- ☑ Thermocouple, RTD & Thermistor Probes, Connectors, Panels & Assemblies
- ☑ Wire: Thermocouple, RTD & Thermistor
- ☑ Calibrators & Ice Point References
- ☑ Recorders, Controllers & Process Monitors
- ☑ Infrared Pyrometers

PRESSURE, STRAIN AND FORCE

- ☑ Transducers & Strain Gages
- ☑ Load Cells & Pressure Gages
- ☑ Displacement Transducers
- ☑ Instrumentation & Accessories

FLOW/LEVEL

- ☑ Rotameters, Gas Mass Flowmeters & Flow Computers
- ☑ Air Velocity Indicators
- ☑ Turbine/Paddlewheel Systems
- ☑ Totalizers & Batch Controllers

pH/CONDUCTIVITY

- ☑ pH Electrodes, Testers & Accessories
- ☑ Benchtop/Laboratory Meters
- ☑ Controllers, Calibrators, Simulators & Pumps
- ☑ Industrial pH & Conductivity Equipment

DATA ACQUISITION

- ☑ Data Acquisition & Engineering Software
- ☑ Communications-Based Acquisition Systems
- ☑ Plug-in Cards for Apple, IBM & Compatibles
- ☑ Datalogging Systems
- ☑ Recorders, Printers & Plotters

HEATERS

- ☑ Heating Cable
- ☑ Cartridge & Strip Heaters
- ☑ Immersion & Band Heaters
- ☑ Flexible Heaters
- ☑ Laboratory Heaters

ENVIRONMENTAL MONITORING AND CONTROL

- ☑ Metering & Control Instrumentation
- ☑ Refractometers
- ☑ Pumps & Tubing
- ☑ Air, Soil & Water Monitors
- ☑ Industrial Water & Wastewater Treatment
- ☑ pH, Conductivity & Dissolved Oxygen Instruments