

**1 YEAR**  
WARRANTY

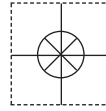

# Ω OMEGA® User's Guide

**Shop online at  
[omega.com](http://omega.com)®**

**e-mail: [info@omega.com](mailto:info@omega.com)  
For latest product manuals:  
[www.omegamanual.info](http://www.omegamanual.info)**

MADE IN CHINA



## **CDTX-111 Conductivity Monitor**



[www.omega.com](http://www.omega.com) [info@omega.com](mailto:info@omega.com)

**Servicing North America:**

**U.S.A.  
Headquarters:**

Omega Engineering, Inc.

Toll-Free: 1-800-826-6342 (USA & Canada only)

Customer Service: 1-800-622-2378 (USA & Canada only)

Engineering Service: 1-800-872-9436 (USA & Canada only)

Tel: (203) 359-1660

Fax: (203) 359-7700

e-mail: [info@omega.com](mailto:info@omega.com)

**For Other Locations Visit [omega.com/worldwide](http://omega.com/worldwide)**

---

The information contained in this document is believed to be correct, but OMEGA accepts no liability for any errors it contains, and reserves the right to alter specifications without notice.

**WARNING:** These products are not designed for use in, and should not be used for, human applications.

# CONTENTS

1.	<b>INTRODUCTION .....</b>	<b>2</b>
2.	<b>FEATURES AND TECHNICAL SPECIFICATIONS .....</b>	<b>2</b>
2.1	<b>Features.....</b>	<b>2</b>
2.2	<b>Technical Specifications.....</b>	<b>2</b>
3.	<b>INSTALLATION.....</b>	<b>3</b>
3.1	<b>Dimension.....</b>	<b>3</b>
3.2	<b>Panel Cut-out.....</b>	<b>4</b>
3.3	<b>User Interface and Description.....</b>	<b>4</b>
3.4	<b>Connection.....</b>	<b>6</b>
4.	<b>SETTING AND OPERATION.....</b>	<b>7</b>
4.1	<b>Switch Measuring and Setting Mode.....</b>	<b>7</b>
4.2	<b>Menu Structure.....</b>	<b>7</b>
4.3	<b>Parameter Setting and Operation.....</b>	<b>9</b>
4.3.1	<b>Set Alarm.....</b>	<b>9</b>
4.3.2	<b>Calibration.....</b>	<b>11</b>
4.3.3	<b>Set Current Output.....</b>	<b>14</b>
4.3.4	<b>Measurement Mode.....</b>	<b>16</b>
4.3.5	<b>Restore Factory Setting.....</b>	<b>16</b>
5.	<b>ERROR CODES.....</b>	<b>17</b>
6.	<b>SENSOR.....</b>	<b>17</b>
7.	<b>STANDARD CONFIGURATION.....</b>	<b>20</b>
8.	<b>OPTIONAL CONFIGURATION.....</b>	<b>20</b>

**CDTX-111 Intelligent On-line Conductivity Monitor**

# **1. INTRODUCTION**

*The CDTX-111 is a microprocessor controlled conductivity measurement instrument. The unit utilizes a multifunction LED to display readings and provide feedback to the user. The unit includes fully configurable control, alarm and feedback with up to two relays and 4-20mA current output sources.*

## **2. FEATURES AND TECHNICAL SPECIFICATIONS**

### **2.1 Features**

- (1) 3-1/2 LED digital with back-lit display*
- (2) Measured conductivity, resistivity, temperature*
- (3) 0 ~ 100°C automatic/manual temperature compensation*
- (4) Manual or Automatic buffer adjustment*
- (5) Restore factory setting function is available*
- (6) Galvanic separation between inputs and outputs and supply voltage*
- (7) Different input for excellent noise rejection*
- (8) High and low programmable alarm, 250V/10A relay output*

### **2.2 Technical Specifications**

- (1) Ranges of measurement : 0~ 18  $M\Omega \cdot cm$  or 0~19.99uS/cm, 0~199.9uS/cm, 0~1999uS/cm*
- (2) Accuracy:  $\pm 0.5\%$  /  $\pm 0.2^\circ C$*
- (3) Linearity:  $\pm 0.1\%$  of range*
- (4) Repeatability:  $\pm 0.1\%$  of range*
- (5) Temperature compensation type: Auto / manual 0°C to 100°C*
- (6) Alarm Output: Two relays outputs (250V/10A), full range with hysteresis adjustable*
- (7) Current output: DC 4~20mA, Opto-isolated outputs, ( 750 $\Omega$  Max. load)*
- (8) Ambient Operating temperature: -10~+55°C*
- (9) Humidity:  $\leq 95\%$*

(10) Power supply: AC110~220V, 50/60Hz

### 3. INSTALLATION

The panel-mounting version is designed to be flush mounted and sealed in a square cut-out in a panel, and is held in place with the two screw clamps provided.

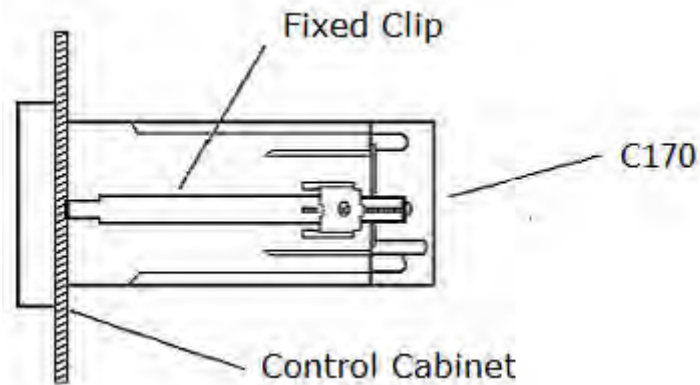

Figure 1: installation diagram

#### 3.1 Dimensions

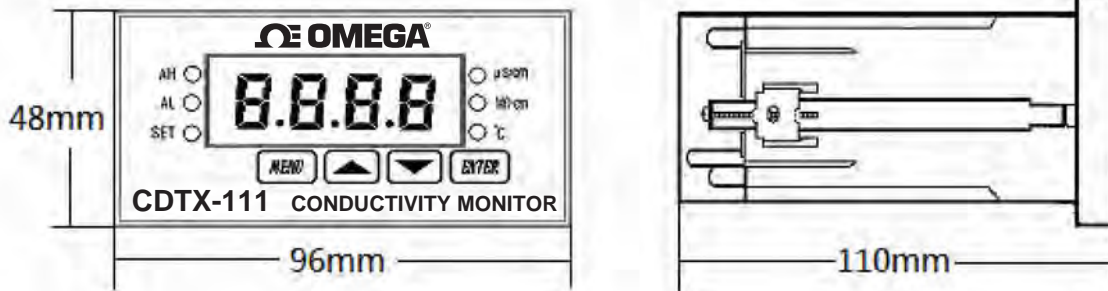
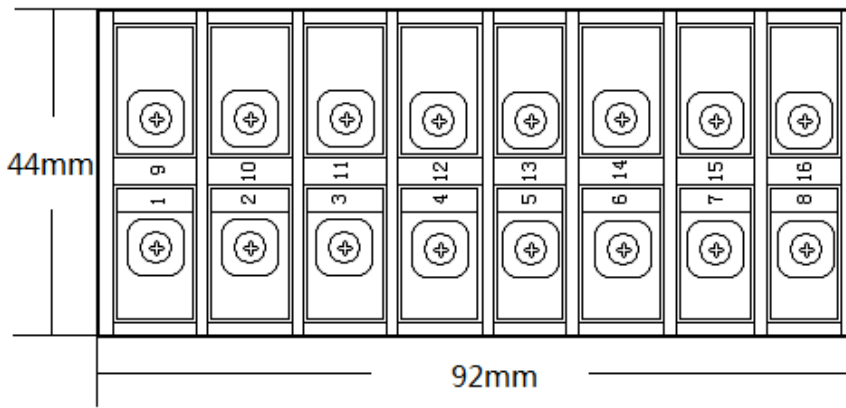

Figure 2 : overall dimensions panel-mounting

### 3.2 Panel Cut-out

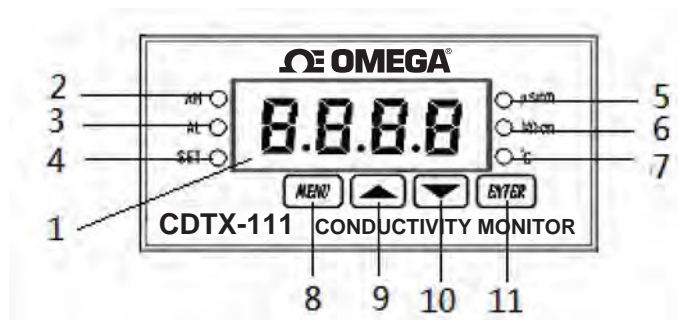

**Figure 3: cut-out diagram**

The panel cut-out for mounting the unit should be 92 mm x 44 mm (+1.0–0.0).

Two screw clamps are supplied and are fitted from the back of the instrument

### 3.3 User Interface and Description









**Figure 4: front panel diagram**

**Front panel description:**

- (1) **LED digital Monitor**, displayed the measured values, and can also be displayed prompt function, parameter values and error codes in interactive.
- (2) **AH alarm light**, Under the conditions of setting high alarm, when the measured pH value of the solution is higher than the value of High alarm, the AH alarm light will be turned on and the high relay (N/O) close; When

*the measured pH value of the solution is lower than the value of High alarm, furthermore lower than the hysteresis, the AH alarm light will be turned off and the high relay (N/O) open.*

- (3) **AL** alarm light, Under the conditions of setting low alarm, when the measured pH value of the solution is lower than the value of low alarm, the AL alarm light will be turned on and the low relay (N/O) close; When the measured pH value of the solution is higher than the value of low alarm, furthermore higher than the hysteresis, the AL alarm light will be turned off and the low relay (N/O) open.*
- (4) **SET** indicator light, the light will be turned on when entering the setting state.*
- (5) **uS/cm** indicator light. When the light is lit in the measurement state, means the measured value is conductivity, and unit is uS/cm.*
- (6) **MΩ · cm** indicator light. When the light is lit in the measurement state, means the measured value is resistivity, and unit is MΩ · cm.*
- (7) indicator light. When the light is lit in the measurement state, means the measured value is Temperature; When the light is lit in the setting state, means the input parameter is Temperature.*
- (8) **MENU** , Press the **MENU** key to enter or exit the setting state.*
- (9)  , In setting state, using the  key the user can cycle through the front menu. To adjust a value, the  key is used to select a digit.*
- (10)  , In the setting state, using the  key the user can cycle through the next menu. To adjust a value, the  key is used to increment the digit.*
- (11) **ENTER** key is the enter button to confirm enter the menu and store the setting parameters.*

### 3.4 Connection

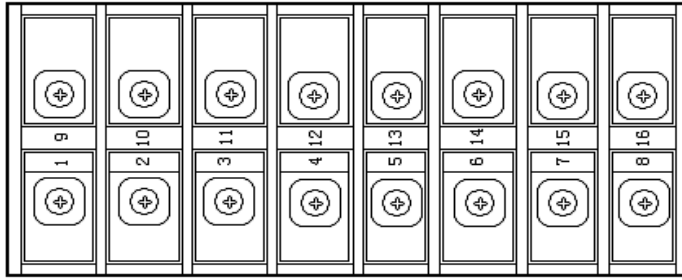

**Figure 5: connection terminals diagram**

**Connection terminals wiring directions:**

- (1) AH, High alarm relay (N/O, normally open)**
- (2) High/Low alarm relay (Common)**
- (3) AL, Low alarm relay (N/O, normally open)**
- (4) Spare**
- (5) Spare**
- (6) Ground**
- (7) Power supply terminal: Connect AC110 ~ 220V**
- (8) Power supply terminal: Connect the power supply phase**
- (9) Conductivity sensor line A (red)**
- (10) Conductivity sensor line A (yellow or white)**
- (11) Spare**
- (12) Temperature sensor 1 (blue or brown)**
- (13) Temperature sensor 2 (black)**
- (14) Spare**
- (15) 4~20mA current Output (-)**
- (16) 4~20mA current Output (+)**



**⚠ CAUTION ! :**

The specified performance of the CDTX-111 is entirely dependent on correct installation. For this reason, the installer should thoroughly read the instructions before attempting to make any electrical connections to the unit.

### 4. SETTING AND OPERATION

After installation, check the connection is correct, then put the sensor into the test solution, preheat for 10 minutes, you can perform the following operations.

#### 4.1 Switch Measuring and Setting Mode

Instrument has two states: measuring state and setting state. After powering up the device enters the measuring state automatically. In the measuring state, press **MENU** to enter the setting state. In the setting state, press **MENU** to return to the measuring state.

#### 4.2 Menu Structure

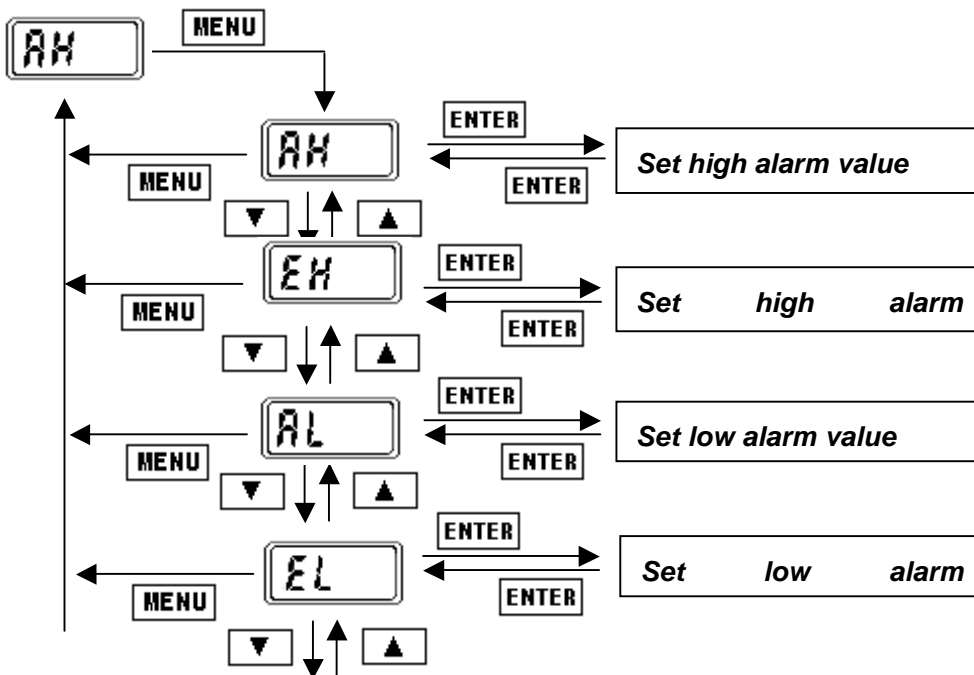

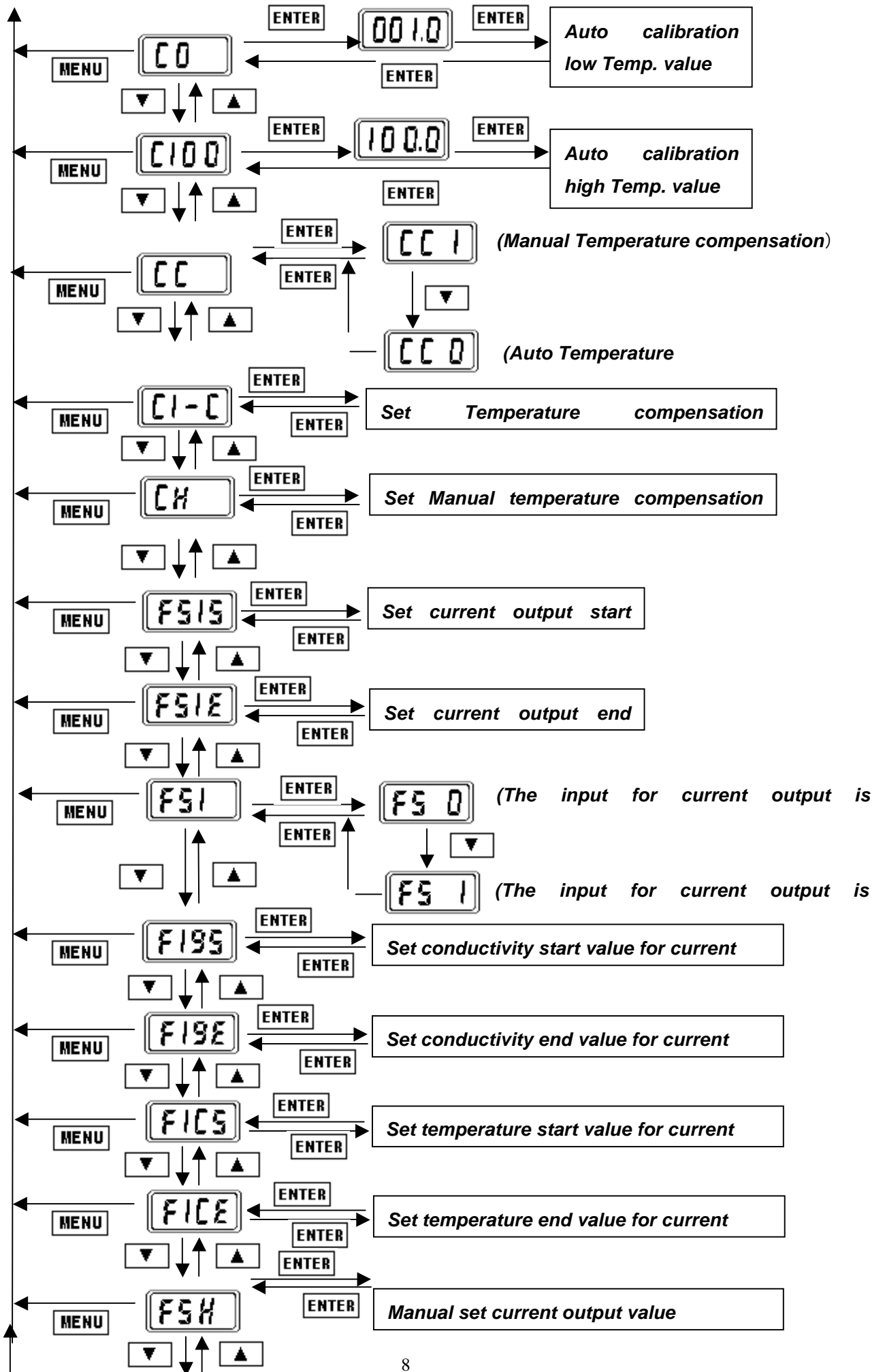

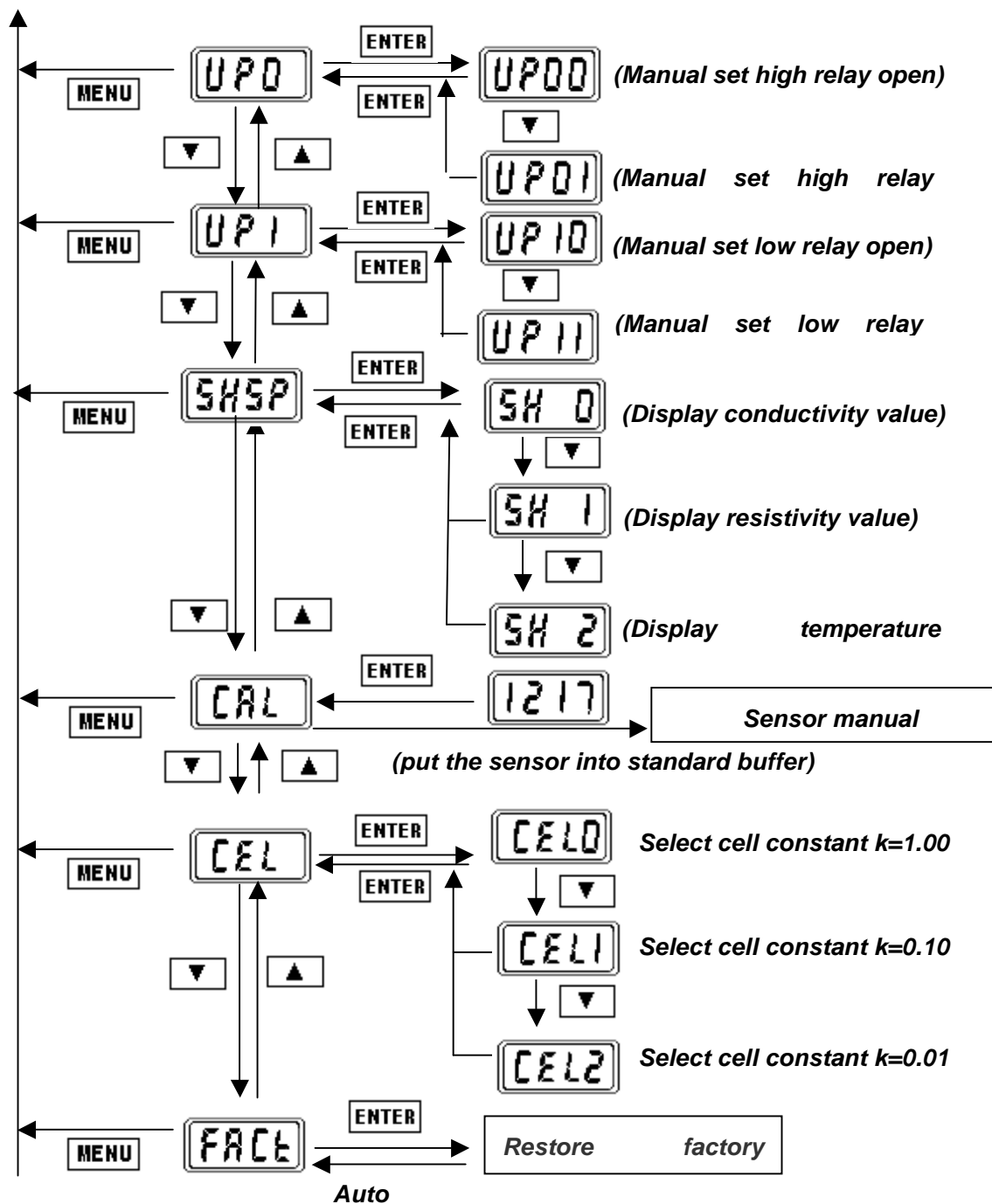

### 4.3 Parameter Setting and Operation

#### 4.3.1 Set Alarm

The CDTX-111 monitor has two alarm outputs designated high alarm (AH) and low alarm (AL). The alarm value and alarm hysteresis can be set within the currently selected measuring range.

**Table 1 Alarm value setting program**

<b>Code</b>	<b>Content</b>	<b>Set range</b>	<b>Unit</b>
<b><u>AH</u></b>	<b>High alarm value</b>	<b>0~18.00/0~1999</b>	<b><math>M\Omega \cdot cm / uS/cm</math></b>
<b><u>EH</u></b>	<b>High alarm hysteresis</b>	<b>0~18.00/0~1999</b>	<b><math>M\Omega \cdot cm / uS/cm</math></b>
<b><u>AL</u></b>	<b>Low alarm value</b>	<b>0~18.00/0~1999</b>	<b><math>M\Omega \cdot cm / uS/cm</math></b>
<b><u>EL</u></b>	<b>Low alarm hysteresis</b>	<b>0~18.00/0~1999</b>	<b><math>M\Omega \cdot cm / uS/cm</math></b>

**\*Note: The setting should meet  $AH-EH \geq AL+EL$**

### **Alarm Relay**

**During normal operation when the alarm is not active, the alarm output will be in its NORMAL condition, the N/O (normal open) contact will be open. When the alarm is active, the alarm output will be in its ALARM condition and therefore the N/O contact will be closed.**

### **Alarm Hysterisis**

**In a normal condition an alarm turns on and off at the same value. For example, if a high alarm turns on at 2000 uS/cm the alarm occurs when the reading increases to 2000 uS/cm. When it decreases through 2000 uS/cm the alarm turns off.**

**Some applications may demand that the alarm turns off at a different value, for a high alarm this would be value lower than the alarm value, and for a low alarm this would be a value higher than the alarm value.**

**The hysteresis value determines the difference between the alarm switch on point and the alarm switch off point. In the case of a high alarm, hysteresis**

causes the alarm to turn off at a value that is less than the alarm value. For a low alarm, hysteresis causes the alarm to turn off at a value greater than the alarm value.

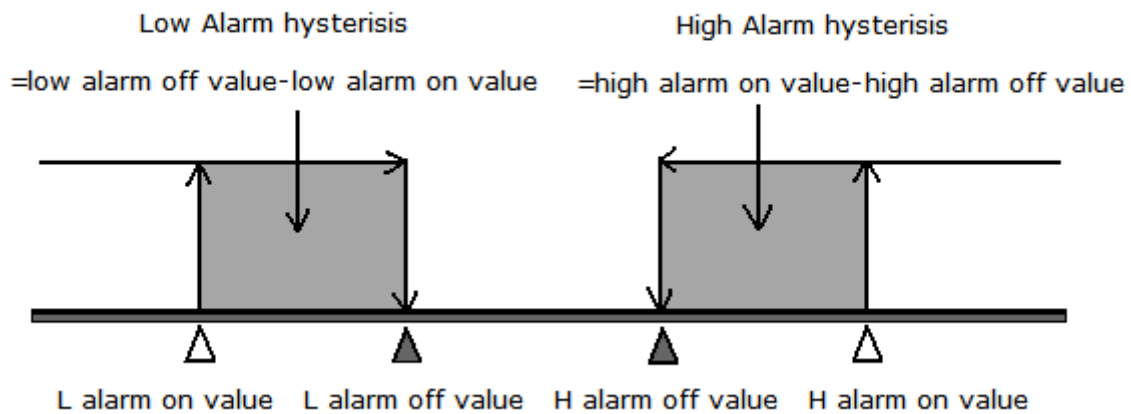

**Figure 6 alarm with hysteresis**

### 4.3.2 Calibration

#### Calibration Intervals

The CDTX-111 Monitor and Sensor combination once calibrated will require calibration checking/recalibration at 3-6 monthly intervals, however this does depend on the application. The calibration of the instrument can be effected by seasonal variations in the measured effluent, however only knowledge of the application can determine the re-calibration interval required.

#### 4.3.2.1 CAL—conductivity sensor manual calibration

**Preparing For Calibration:**

- ☹ Value known conductivity buffer 100ml;
- ☹ Pure water 300~500ml;
- ☹ Use pure water to wash the sensor, and then make it dry;
- ☹ Use thermometer to measure the temperature of buffer;
- ☹ Select manual temperature compensation in the instrument menu and input the temperature value of buffer, set the temperature compensation coefficient is 0.

***Specific operations: select CAL in the menu and put the dry and clean sensor into the known conductivity buffer solution, press **ENTER** to enter its program, then the instrument displays the measured value of the solution, and in flashing mode which is different from the measurement states. After the measurement data is stable then press **ENTER** again, now only the first digit flashing in the display data means it is modify bit. Press **DOWN** to choose the modification bit, press **UP** key to modify the data, make the display value as same as the conductivity value of the solution, press **ENTER** to store the calibration data(This value is stored even after power failure), and return to the setting state.***

#### **4.3.2.2 C0、C100—temperature calibration**

***CDTX-111 has temperature measurement function, for the automatic temperature compensation, and also can be displayed on the monitor. Temperature calibration requires a high and a low constant temperature environment. Such as ice water mixture (0°C) and boiling distilled water (100°C). C0 is used to calibrate 0°C. select C0 in the menu and put the sensor into 0°C environment, press **ENTER** to store the calibration data , and return to the setting state. The Method of calibrate 100°C is as same as calibrate 0°C.***

**Table 2 Temperature calibration program content**

<b>Code</b>	<b>Content</b>	<b>Direction</b>
<b>C0</b>	<b>Auto calibrate temperature=0°C</b>	<b>Use Ice water mixture (0°C) to calibrate</b>
<b>C100</b>	<b>Auto calibrate temperature=100°C</b>	<b>Use boiling water (100°C) to calibrate</b>

#### **4.3.2.3 CC—auto/manual temperature compensation switch**

*CDTX-111 has Auto and manual temperature compensation function. The user can select between two modes of compensation by the CC in the menu. Press **ENTER** into CC and display CC0 or CC1. CC0 is Auto temperature compensation, CC1 is manual temperature compensation. Press **UP** to switch it, then press **ENTER** to store and return to the setting state.*

#### **4.3.2.4 C1-C—set temperature compensation coefficient**

*The temperature compensation coefficient is different for each type of solution, so the temperature compensation coefficient is designed to be adjustable (25°C as the reference), and the range is 0~±10%. Select C1-C in the menu, press **ENTER** into it and display the original value, use **DOWN** and **UP** to modify it, then press **ENTER** to store and return to the setting state. The temperature compensation coefficient works both in automatic and manual temperature compensation.*

*The Calculation Method of coefficient*

$$\xi = \frac{\text{cond.35}-\text{cond.25}}{\text{Cond.25}} \times 100\%$$

**Remark:** *cond.25=the conductivity value at t=25°C;  
cond.35=the conductivity value at t=35°C*

#### **4.3.2.5 CH—set manual temperature**

*In this mode the instrument should be set with the “CC1” and the user*

can set the solution temperature (0~100°C) in the **CH** menu. Press **ENTER** into **CH** and display the original value, use **UP** and **DOWN** to modify it, then press **ENTER** to store and return to the setting state.

**Table 3 Temperature compensation program**

<b>Code</b>	<b>Content</b>	<b>Direction</b>
<b>CC</b>	<b>Auto/manual temp. compensation switch</b>	<b>0=Auto/1=manual</b>
<b>C1-C</b>	<b>Temp. compensation coefficient setting</b>	<b>Range: 0~±10%</b>
<b>CH</b>	<b>Manual temperature setting</b>	<b>Range: 0~100°C</b>

### 4.3.3 Set Current Output

**CDTX-111** has one 4~20mA current output. The user can select the input source: conductivity or temperature. And the current output can be set work over the whole range of the input source.

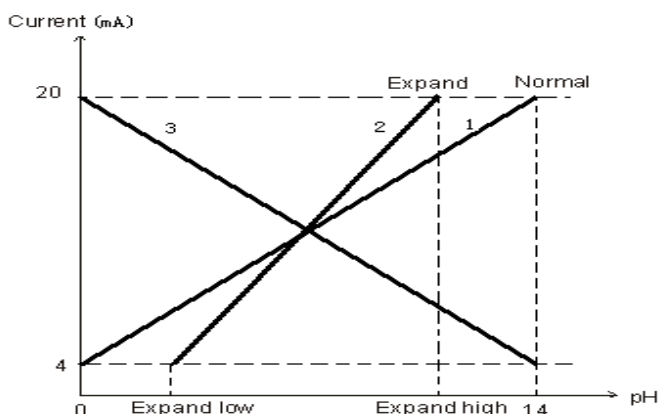

**Figure 7 Current span curve**

The output can be set work over the whole of selected measurement range (curve1) or a portion of it by setting of the output start and end values (curve2). It is also possible to configure the output to work reverse to normal, i.e. a 4 – 20 mA output where 20 mA corresponds to the zero display value and 4 mA corresponding to the full scale value. (curve3).



#### 4.3.3.1 FSIS、FSIE—set current output start and end value

Select FSIS in the menu, press **ENTER** into it and display the original current output start value, use **DOWN** and **UP** to modify it, then press **ENTER** to store and return to the setting state.

The same method select FSIE to set the current output end value.

#### 4.3.3.2 FSI—select the input for the current output

Select FSI in the menu, press **ENTER** into it and display FS 0 or FS 1. FS 0 is conductivity iutput, FS 1 is temperature as the input. Press **UP** to switch it, then Press **ENTER** to store and return to the setting state.

*Table 6 Set current output*

Code	Content	Direction
<u>FSIS</u>	Current output start value	4.00~20.00 mA
<u>FSIE</u>	Current output end value	4.00~20.00 mA
<u>FSI</u>	The input for the current output	0: conductivity 1: temperature

#### 4.3.3.3 FlgS、FlgE、FICS、FICE—set input value range for the current output

After selecting the input parameters, you can set its start value and end value. Select FlgS in the menu, press **ENTER** into it and display the original conductivity start value, use **DOWN** and **UP** to modify it, then press **ENTER** to store and return to the setting state. The same method select FlgE to set the conductivity end value.

Likewise, select FICS and FICE to set the temperature start and end value for current output.

**Table 7 Set input range for the current output**

Code	Content	Range
<u>FlgS</u>	Conductivity start value	0~1999uS/cm (k=1.0)
<u>FlgE</u>	Conductivity end value	0~1999uS/cm (k=1.0)
<u>FICS</u>	Temperature start value	0~100°C
<u>FICE</u>	Temperature end value	0~100°C

#### 4.3.4 SHSP—Measurement Mode

CDTX-111 has conductivity, resistivity, TDS and temperature four modes of measurement and display functions, it can be selected in the SHSP program. Select SHSP in the menu, press **ENTER** into it and display SH 0 or SH 1 or SH 2. SH 0 is conductivity mode, SH 1 is resistivity mode, SH 2 is temperature mode. Press **UP** to switch it, then Press **ENTER** to store and return to the setting state. The indicator light also changes to indicate that the display state changes. The corresponding parameters in the setting also will automatically change.

**\*NOTE:** The sensor should be changed when switch the measurement mode.

**Table 8 Measurement Mode**

Code	Content	Indicator light	Cell constant
<u>SH 0</u>	Display conductivity	uS(mS)/cm	K=0.01/0.1/1.0
<u>SH 1</u>	Display resistivity value	MΩ · cm lights	K=0.01
<u>SH 2</u>	Display Temperature	C/F lights	K=0.01/0.1/1.0

#### 4.3.5 FACT—Restore Factory Setting

Select FACT in the menu, press **ENTER** into it and display HHHH. At this moment the instrument is being restored factory setting, about 10 seconds it will automatically returns to FACT, restore factory setting is completed. After this process, all value the user set before becomes the factory

*calibration value. This function is generally used for replace with new sensor or data confusion. Generally after restored factory setting, it need recalibration before using.*

## **5. ERROR CODES**

*When the instrument detects an error condition, an error code will be displayed. All the error codes are described below.*

*Table 9 Error codes*

<b>Code</b>	<b>Content</b>	<b>Solve methods</b>
<b>Er02</b>	<b>Measurement value out of range</b>	<b>Check whether the choice of cell constant is suitable and replace the correct one</b>
<b>Er03</b>	<b>Temperature sensor failure</b>	<b>1. Check whether the temperature sensor connected with the monitor properly 2. Check whether the temp. compensation (menu CC) setting correct</b>

## **6. SENSOR**

*We use foreign advance technology to manufacture our conductivity sensor. The quality of the sensor is excellence and it can be used in industry province with all kind of conductivity monitor.*

### **6.1 Sensor Features**

- 🔊 High sensitivity and accuracy with reliability and durability**
- 🔊 Stainless material**
- 🔊 Quickly response (within two seconds) and stability**
- 🔊 Unique structure preventing the sensor from pollution and blockage**
- 🔊 Easy to assemble and clean**

## 6.2 Sensor Parameters

*Table 10 Sensor parameters*

	<b>CDE-100-001</b>	<b>CDE-100-01</b>	<b>CDE-100-1</b>
<b>Parameter</b>	<b>Resistivity</b>	<b>Conductivity</b>	<b>Conductivity</b>
<b>Medium</b>	<b>Pure Water</b>	<b>Water</b>	<b>Water</b>
<b>cell constant</b>	<b>0.01</b>	<b>0.1</b>	<b>1.0</b>
<b>Range</b>	<b>0~18MΩ or 0~19.99us/cm</b>	<b>0~199.9us/c m</b>	<b>0~1999 us/cm</b>
<b>Temp. range</b>	<b>0~60°C</b>	<b>0~60°C</b>	<b>0~60°C</b>
<b>Temperature Measurement</b>	<b>0~60°C</b>	<b>0~60°C</b>	<b>0~60°C</b>
<b>Compensation Resistor</b>	<b>10K</b>	<b>10K</b>	<b>10K</b>
<b>Quantity of threads</b>	<b>1</b>	<b>1</b>	<b>1</b>
<b>Thread Size</b>	<b>1/2" NPT</b>	<b>1/2" NPT</b>	<b>1/2" NPT</b>
<b>Max pressure</b>	<b>0.6MPa</b>	<b>0.6MPa</b>	<b>0.6MPa</b>
<b>Cables Length</b>	<b>5m</b>	<b>5m</b>	<b>5m</b>
<b>Max Length</b>	<b>50m</b>	<b>20m</b>	<b>20m</b>

## 6.3 The Use Situation of Conductivity Sensor

**Table 11 The conductivity of different liquid in 25°C**

<b>situation</b>	<b>conductivity</b>
<b>Pure water</b>	<b>0.05 us/cm</b>
<b>Boiler water</b>	<b>0.05~1 us/cm</b>
<b>Deionized water</b>	<b>0.5 us/cm</b>
<b>Distilled water</b>	<b>0.1~10 us/cm</b>
<b>Softened water</b>	<b>1~80 us/cm</b>
<b>Mineral water</b>	<b>10 us/cm</b>
<b>Beverages</b>	<b>0.5~1 ms/cm</b>
<b>Waste water</b>	<b>0.9~9 ms/cm</b>
<b>KCL Solution</b>	<b>1.4ms/cm</b>
<b>Brine</b>	<b>1~80ms/cm</b>
<b>Industrial process water</b>	<b>7~140ms/cm</b>
<b>Seawater</b>	<b>53 ms/cm</b>
<b>10%NaOH</b>	<b>355 ms/cm</b>
<b>31%HNO3</b>	<b>865 ms/cm</b>

**6.4 Sensor Dimension (Unit: mm)**

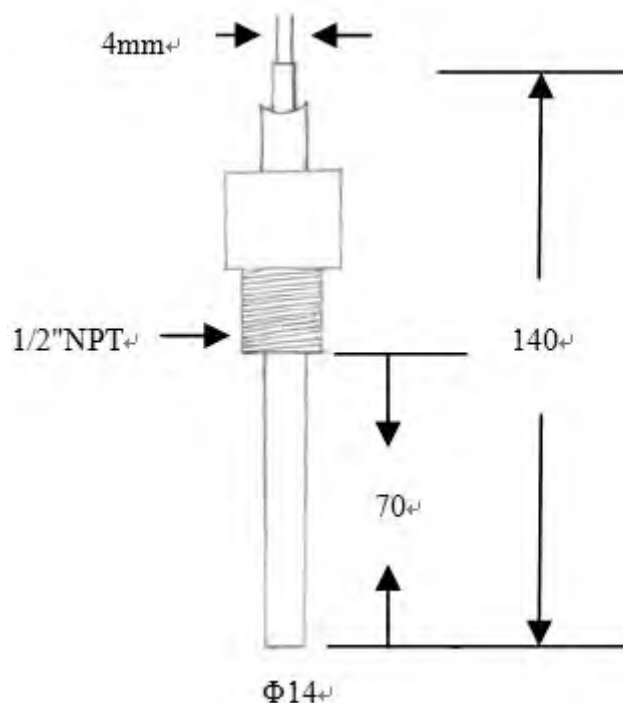

**Figure 7 Sensor dimension for  $k=0.01/0.1/1.0$**

## **6.5 Maintenance**

- (1) Attaching sensors are precision devices, can not disassemble in order to avoid changing the cell constant, causing measurement errors.**
- (2) Sensors can not be immersed in the strong acid or alkali to avoid surface damage of the sensors, affecting the cell constant and sensitivity.**  
**Correct method: When the sensor is dirty, immerse in the 10% hydrochloric acid for a short time, then rinse with pure water that maintain the sensor surface clean.**
- (3) Sensors cable is a dedicated cable, can not be replaced or extended by users self.**
- (4) Instrument should be installed in a relatively dry environment or the control box, to avoid instrument failure or measurement error caused by damp.**

## **7 STANDARD CONFIGURATION**

- ☛ CDTX-111 monitor**
- ☛ Mounting fixing of monitor**
- ☛ Operation guide**
- ☛ Inspection report**

## **8 OPTIONAL CONFIGURATION**

- ☛ Conductivity sensor CDE-100-01/CDE-100-1 (cable length 5 meters)**
- ☛ Resistivity sensor CDE-100-001 (cable length 5 meters)**
- ☛ Extension cable**

## WARRANTY/DISCLAIMER

OMEGA ENGINEERING, INC. warrants this unit to be free of defects in materials and workmanship for a period of **13 months** from date of purchase. OMEGA's WARRANTY adds an additional one (1) month grace period to the normal **one (1) year product warranty** to cover handling and shipping time. This ensures that OMEGA's customers receive maximum coverage on each product.

If the unit malfunctions, it must be returned to the factory for evaluation. OMEGA's Customer Service Department will issue an Authorized Return (AR) number immediately upon phone or written request. Upon examination by OMEGA, if the unit is found to be defective, it will be repaired or replaced at no charge. OMEGA's WARRANTY does not apply to defects resulting from any action of the purchaser, including but not limited to mishandling, improper interfacing, operation outside of design limits, improper repair, or unauthorized modification. This WARRANTY is VOID if the unit shows evidence of having been tampered with or shows evidence of having been damaged as a result of excessive corrosion; or current, heat, moisture or vibration; improper specification; misapplication; misuse or other operating conditions outside of OMEGA's control. Components in which wear is not warranted, include but are not limited to contact points, fuses, and triacs.

**OMEGA is pleased to offer suggestions on the use of its various products. However, OMEGA neither assumes responsibility for any omissions or errors nor assumes liability for any damages that result from the use of its products in accordance with information provided by OMEGA, either verbal or written. OMEGA warrants only that the parts manufactured by it will be as specified and free of defects. OMEGA MAKES NO OTHER WARRANTIES OR REPRESENTATIONS OF ANY KIND WHATSOEVER, EXPRESS OR IMPLIED, EXCEPT THAT OF TITLE, AND ALL IMPLIED WARRANTIES INCLUDING ANY WARRANTY OF MERCHANTABILITY AND FITNESS FOR A PARTICULAR PURPOSE ARE HEREBY DISCLAIMED. LIMITATION OF LIABILITY: The remedies of purchaser set forth herein are exclusive, and the total liability of OMEGA with respect to this order, whether based on contract, warranty, negligence, indemnification, strict liability or otherwise, shall not exceed the purchase price of the component upon which liability is based. In no event shall OMEGA be liable for consequential, incidental or special damages.**

CONDITIONS: Equipment sold by OMEGA is not intended to be used, nor shall it be used: (1) as a "Basic Component" under 10 CFR 21 (NRC), used in or with any nuclear installation or activity; or (2) in medical applications or used on humans. Should any Product(s) be used in or with any nuclear installation or activity, medical application, used on humans, or misused in any way, OMEGA assumes no responsibility as set forth in our basic WARRANTY/DISCLAIMER language, and, additionally, purchaser will indemnify OMEGA and hold OMEGA harmless from any liability or damage whatsoever arising out of the use of the Product(s) in such a manner.

## RETURN REQUESTS/INQUIRIES

Direct all warranty and repair requests/inquiries to the OMEGA Customer Service Department. BEFORE RETURNING ANY PRODUCT(S) TO OMEGA, PURCHASER MUST OBTAIN AN AUTHORIZED RETURN (AR) NUMBER FROM OMEGA'S CUSTOMER SERVICE DEPARTMENT (IN ORDER TO AVOID PROCESSING DELAYS). The assigned AR number should then be marked on the outside of the return package and on any correspondence.

The purchaser is responsible for shipping charges, freight, insurance and proper packaging to prevent breakage in transit.

FOR **WARRANTY** RETURNS, please have the following information available BEFORE contacting OMEGA:

1. Purchase Order number under which the product was PURCHASED,
2. Model and serial number of the product under warranty, and
3. Repair instructions and/or specific problems relative to the product.

FOR **NON-WARRANTY** REPAIRS, consult OMEGA for current repair charges. Have the following information available BEFORE contacting OMEGA:

1. Purchase Order number to cover the COST of the repair,
2. Model and serial number of the product, and
3. Repair instructions and/or specific problems relative to the product.

OMEGA's policy is to make running changes, not model changes, whenever an improvement is possible. This affords our customers the latest in technology and engineering.

OMEGA is a registered trademark of OMEGA ENGINEERING, INC.

© Copyright 2016 OMEGA ENGINEERING, INC. All rights reserved. This document may not be copied, photocopied, reproduced, translated, or reduced to any electronic medium or machine-readable form, in whole or in part, without the prior written consent of OMEGA ENGINEERING, INC.

# Where Do I Find Everything I Need for Process Measurement and Control? **OMEGA...Of Course!** *Shop online at [omega.com](http://omega.com)<sup>sm</sup>*

## **TEMPERATURE**

- Thermocouple, RTD & Thermistor Probes, Connectors, Panels & Assemblies
- Wire: Thermocouple, RTD & Thermistor
- Calibrators & Ice Point References
- Recorders, Controllers & Process Monitors
- Infrared Pyrometers

## **PRESSURE, STRAIN AND FORCE**

- Transducers & Strain Gages
- Load Cells & Pressure Gages
- Displacement Transducers
- Instrumentation & Accessories

## **FLOW/LEVEL**

- Rotameters, Gas Mass Flowmeters & Flow Computers
- Air Velocity Indicators
- Turbine/Paddlewheel Systems
- Totalizers & Batch Controllers

## **pH/CONDUCTIVITY**

- pH Electrodes, Testers & Accessories
- Benchtop/Laboratory Meters
- Controllers, Calibrators, Simulators & Pumps
- Industrial pH & Conductivity Equipment

## **DATA ACQUISITION**

- Data Acquisition & Engineering Software
- Communications-Based Acquisition Systems
- Plug-in Cards for Apple, IBM & Compatibles
- Data Logging Systems
- Recorders, Printers & Plotters

## **HEATERS**

- Heating Cable
- Cartridge & Strip Heaters
- Immersion & Band Heaters
- Flexible Heaters
- Laboratory Heaters

## **ENVIRONMENTAL MONITORING AND CONTROL**

- Metering & Control Instrumentation
- Refractometers
- Pumps & Tubing
- Air, Soil & Water Monitors
- Industrial Water & Wastewater Treatment
- pH, Conductivity & Dissolved Oxygen Instruments