

3 YEAR
WARRANTY

RoHS 2 Compliant

Ω OMEGA® **User's Guide**

Shop online at
omega.com®

e-mail: info@omega.com
For latest product manuals:
omegamanual.info

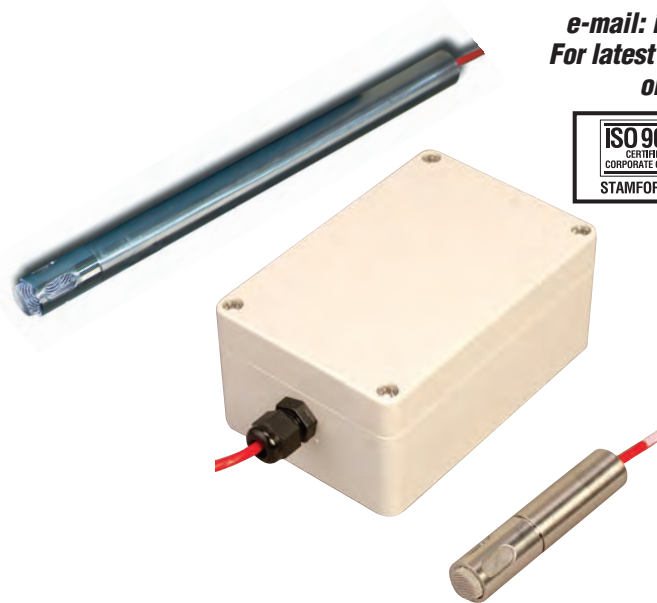

HX15 **High Temperature** **Relative Humidity/Temperature** **Probe Transmitter**



OMEGAnet® Online Service
omega.com

Internet e-mail
info@omega.com

Servicing North America:

U.S.A.: Omega Engineering, Inc., One Omega Drive, P.O. Box 4047
ISO 9001 Certified Stamford, CT 06907-0047 USA
Toll-Free: 1-800-826-6342 Tel: (203) 359-1660
FAX: (203) 359-7700 e-mail: info@omega.com

Canada: 976 Bergar, Laval (Quebec), H7L 5A1 Canada
Toll-Free: 1-800-826-6342 TEL: (514) 856-6928
FAX: (514) 856-6886 e-mail: info@omega.ca

For immediate technical or application assistance:

U.S.A. and Canada: Sales Service: 1-800-826-6342/1-800-TC-OMEGA®
Customer Service: 1-800-622-2378/1-800-622-BEST®
Engineering Service: 1-800-872-9436/1-800-USA-WHEN®

Mexico TEL: 001 (203) 359-1660 FAX: 001 (203) 359-7700
Latin America e-mail: espanol@omega.com

Servicing Asia:

China: 1698 Yi Shan Road, Unit 102, Min Hang District
Shanghai, China 201103 P.R.C.
Hotline: 800 819 0559/400 619 0559
e-mail: info@cn.omega.com

Servicing Europe:

Benelux: Toll-Free: 0800 099 3344 TEL: +31 20 347 21 21
FAX: +31 20 643 46 43 e-mail: sales@omegaeng.nl

Czech Republic: Frystaska 184, 733 01 Karviná, Czech Republic
TEL: +420-59-6311899 FAX: +420-59-6311114
e-mail: info@omegashop.cz

France: Toll-Free: 0805 466 342 TEL: 01 57 32 48 17
FAX: 01 57 32 48 18 e-mail: esales@omega.fr

Germany/ Austria: Daimlerstrasse 26, D-75392 Deckenpfronn, Germany
Toll-Free: 0800 8266342 TEL: +49 (0) 7056 9398-0
FAX: +49 (0) 7056 9398-29 e-mail: info@omega.de

United Kingdom: OMEGA Engineering Ltd.
ISO 9001 Certified One Omega Drive, River Bend Technology Centre, Northbank
Irlam, Manchester M44 5BD United Kingdom
Toll-Free: 0800-488-488 TEL: +44 (0) 161 777-6611
FAX: +44 (0) 161 777-6622 e-mail: sales@omega.co.uk

It is the policy of OMEGA Engineering, Inc. to comply with all worldwide safety and EMC/EMI regulations that apply. OMEGA is constantly pursuing certification of its products to the European New Approach Directives. OMEGA will add the mark to every appropriate device upon certification.

The information contained in this document is believed to be correct, but OMEGA accepts no liability for any errors it contains, and reserves the right to alter specifications without notice.

WARNING: These products are not designed for use in, and should not be used for, human applications.

TABLE OF CONTENTS

A. General Description	1.
B. Unpacking	1.
C. Theory of Operation	2.
D. Terminal Connections	3.
E. Wiring Example	3.
F. Mounting	4.
G. Calculations	5.
H. R H Calibration	6.
I. Temp. Calibration	7.
J. Maintenance	7.
K. Specifications	8.

A. GENERAL DESCRIPTION

The stainless steel probe provides relative humidity as well as temperature out puts. A thin film polymer capacitor senses relative humidity, while temperature is monitored by a 1000 Ohm platinum RTD. The sensors are protected by a stainless steel filter cap easily removed for cleaning. The probe is connected to an electronics enclosure with a 40 inch (1m) Teflon cable. The enclosure contains the calibration trimmers, signal and power connections via two terminal blocks. The probe is available in two configurations, as a 2.5" (64 mm) probe with a wall mounting clip, and as an 8.5" (216 mm) probe with an adjustable duct flange.

B. UNPACKING

Verify that the following parts have been received.

1. Remove probe with cable and electronics enclosure.
2. Instruction manual.
3. Wall mounting clip [for 2.5" (64 mm) probe].
4. 2 piece duct flange, with o-ring, (3) screws, and a gasket.
[for 8.5" (216 mm) probe]

C. THEORY OF OPERATION

A 4 to 20 milliamp loop is a series current loop in which a transmitter will vary the current flow depending upon the parameter being measured (Relative Humidity or Temperature). Advantages of a current output over a voltage output is that is less susceptible to noise interference and allows the connection of more than one meter or recorder to the loop as long as the maximum resistance is not exceeded.

The typical current loop will consist of a power supply, transmitter, and a meter to measure the current flow. The loop resistance is the sum of the impedance of the meter(s) and the lead wire. The maximum allowable loop impedance of the probe is found by the Formula:

$$R_{max} = (\text{power supply voltage} - 7 \text{ volts}) / .02 \text{ amps}$$

Example: when using a 24 VDC power supply:

$$R_{max} = (24 - 7) / .02 = 850 \text{ ohms (for total wire length to and from the transmitter).}$$

AWG WIRE SIZE RESISTANCE PER 1000 FEET

24	25 OHMS
22	15 OHMS
20	10 OHMS
18	6 OHMS
16	4 OHMS

If the meter or recorder being used accepts only voltage, convert the current to voltage by installing a 250 ohm resistor across the input terminals of the recorder to obtain a 1 to 5 volts input.

D. TERMINAL CONNECTIONS AND TRIM POTS

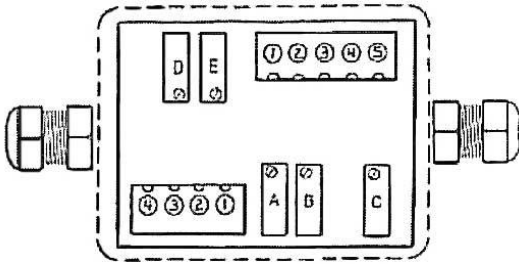

TRIMPOTS TYPE

- A. RH GAIN
- B. RH ZERO
- C. RH OFFSET
- D. TEMP GAIN
- E. TEMP ZERO

<u>PROBE TERMINALS</u>	<u>CABLE WIRE</u>	<u>TYPE</u>	<u>OUTPUT TERMINALS</u>	<u>TYPE</u>
1	black	RTD	1	-RH
2	white	RTD	2	+RH
3	green	RH	3	-TEMP
4	red	RH	4	+TEMP
5	shield	—		

E. WIRING EXAMPLES

TYPICAL CURRENT HOOKUP

Wires R1 and R2 can be combined into one single wire with a jumper at pins (4) and (2). This will result in 3 wires instead of 4.

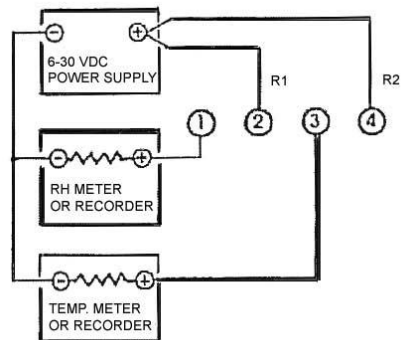

PROBE INSTALLATION

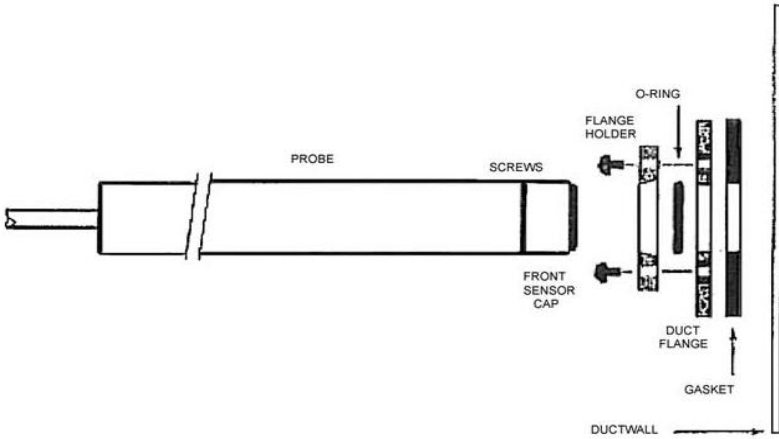

F. MOUNTING

A. DUCT MOUNTING STEPS

1. Slide flange holder onto probe with countersink hole facing front of probe as shown.
2. Position o-ring on probe at desired position (for depth into duct).
3. Slide duct flange onto probe as shown.
4. Fasten with (3) 6/32 screws and tighten evenly until secure.
5. Position gasket between duct flange and duct wall and fasten assembly to duct with (4) #6 sheet metal screws (not included).
6. Loosening the 6/32 screws allows for repositioning or removal of the probe without having to remove the duct flange from the wall.

The duct wall requires a $11/16''$ (.684'' or 17.5 mm) hole for probe, with (4) mounting holes (for #6 sheet metal screws) evenly spaced on a 2.0'' (51 mm) circle. Use duct flange as template.

B. WALL MOUNTING

1. Fasten metal clip to wall.
2. Snap probe into clip.

G. RH AND TEMPERATURE CALCULATIONS

1. Maximum current loop impedance for RH or temperature.

$$R_{max} = (V \text{ supply} - 7 \text{ volts}) / .02 \text{ amps}$$

2. RH current output (i = current output in milliamperes)

3. Temperature current output.

$$oC = (i-4) \times 220/16) - 40 \quad iC = (oC + 40) \times (16/220) + 4$$

$$oF = (i-4) \times (396/16) - 40 \quad iF = (oF + 40) \times (16/396) + 4$$

The upper limit of the humidity measurement range decreases based on temperature. The humidity measurement limit decreases as follows:

2.20% per °C from 95 to 120°C (1.11% per °F from 203 to 248°F)

1.00% per °C from 120 to 140°C (0.56% per °F from 248 to 284°F)

0.50% per °C from 140 to 160°C (0.28% per °F from 284 to 320°F)

0.25% per °C from 160 to 180°C (0.14% per °F from 320 to 356°F)

For example, at 120°C the upper humidity limit decreases to about 45% ((120-95)(2.20%) = 55% decrease which is 45%), at 180°C it is reduced to about 10%.

To calculate the RH accuracy, we'll use the accuracy specs given in the specifications section:

+/-2%RH at 25°C and -40° to 150°C at 0.05 % RH/°C.

To clarify lets take an example,

RH accuracy at 120°C,

$$= +/- (2\% + (120-25)0.05\%) = +/- (2\% + 4.75\%)$$

$$= +/- 6.75\%$$

So the accuracy at 120°C is +/- 6.75% and the upper humidity measurement limit is 45% RH.

H. RH CALIBRATION

Refer to Section D for the location of trim pots A and B.

Note: The HX92-CAL Relative Humidity Calibration Kit is for providing the “low” and “high” RH environments for this procedure. The salt solutions in this kit are prepared according to ASTM standard E104 -85 to provide 11.3% and 75.3% relative humidity environments. The containers provided in the kit are designed to fit with these instruments.

1. Turn the span (trim pot A) all the way up (clockwise).
2. Turn the zero (trim pot B) all the way down (counter-clockwise).
3. Place the sensor in the low (11.3%) RH environment. Allow at least one hour for stabilization or until the output stops changing.
4. Verify the output is $4 \pm .02$ mA. If it is not, return the unit to Omega for evaluation and repair.
5. Adjust the zero (trim pot B) to the point where it just starts to cause a change in the output.
6. Place the sensor in the high (75.3%) RH environment. Allow at least one hour for stabilization or until the output stops changing.
7. Adjust the span (trim pot A) so the output is equivalent to the difference between low and high RH environments. Example: $75.3\% - 11.3\% = 64\%$ which is equivalent to 14.24 mA.
8. Adjust the sensor in the low RH environment and allow at least one hour for stabilization or until the output stops changing. Verify the output is equivalent to the low RH environment. Example: 11.3% is equivalent to 5.81 mA.

I. TEMPERATURE CALIBRATION

Temperature is factory calibrated only, and does not require any further calibrations.

J. MAINTENANCE

If the probe is operated in a dusty environment, the protective sensor filter, if clogged, may be removed for cleaning. Unscrew filter and gently blow compressed air through screen. If necessary, use a soft brush to remove lint from sensors.

If the sensors are subjected to 100% condensation, they must be dried to obtain correct readings. There is no permanent calibration shift, nor is recalibration necessary if 100% condensation occurs.

The instrument should not be exposed to high concentrations of ammonia or alcohol vapors. However, any environment that is breathable under normal HVAC applications should not affect the sensors. To maintain original specifications, it is generally recommended that the RH sensor be recalibrated on an annual basis depending upon operating conditions. The temperature sensor does not require calibration.

K. SPECIFICATIONS

1. Relative Humidity: Thin film polymer capacitor.
Input Voltage Range: 7 to 30 VDC (polarity protected).
Range, Accuracy: 3% RH to 95% RH (@-40 to 95°C)*, ±2%RH at 25°C
Typical Temp. Characteristics: -40°C to 150°C at .05%RH/°C
Output: 4 to 20 mA. For 0%RH to 100%RH.
Time Constant: Under 30 seconds, 90% response at 25°C in 1M/sec air.
* See RH and Temperature Calculations section for full range.
2. Temperature: Thin film 1000 ohm platinum RTD.
Input Voltage Range: 7 to 30 VDC (polarity protected).
Range, Accuracy: -40°C to 180°C (-40°F to 356°F), ±0.5°C (±1°F)
Output: 4 to 20 ma. For -40°C to 180°C (-40°F to 356°F)
Time Constant: Under 4 seconds, 60% response in 1m/sec air.
3. Mechanical
Standard Probe: Stainless steel, 2.5” (64 mm) x .625” (16 mm)
diameter. 40” (1m) Teflon cable, metal wall mounting clip.

Duct Probe: Stainless steel, 8.5” (216 mm) x .625” (16 mm)
diameter. 40” (1m) Teflon cable.

Duct Flange: 2.75” (70mm) dia., duct hole 11/16 (.684”,
17.5 mm) dia. With 4 mounting holes .156(4 mm)
diameter (for #6 sheet metal screws), on 2.00”
(51mm) circle.

Electronics: Operating temp. -20°C to 70°C(-4°F to 158°F)
ABS housing 4.72” (120 mm) x 3.14” (80 mm) x
2.16” (55 mm) H meets NEMA 1,2,3,4,4X,5,12
and 13 specifications.

Connectors: Liquid-tight with neoprene gland for .09” to .265”
diameter cable.
4-pin plug in screw terminal block for output connections.
5-pin screw terminal block for cable wire input
connections, accepts #14 to #22 AWG wires.

Weight: 2.5” (64 mm) probe with housing 14 oz. (397 grams).
8.5” (216 mm) probe with housing and flange 20 oz. (567
grams).



WARRANTY/DISCLAIMER

OMEGA ENGINEERING, INC. warrants this unit to be free of defects in materials and workmanship for a period of **37 months** from date of purchase. OMEGA's WARRANTY adds an additional one (1) month grace period to the normal **three (3) year product warranty** to cover handling and shipping time. This ensures that OMEGA's customers receive maximum coverage on each product.

If the unit malfunctions, it must be returned to the factory for evaluation. OMEGA's Customer Service Department will issue an Authorized Return (AR) number immediately upon phone or written request. Upon examination by OMEGA, if the unit is found to be defective, it will be repaired or replaced at no charge. OMEGA's WARRANTY does not apply to defects resulting from any action of the purchaser, including but not limited to mishandling, improper interfacing, operation outside of design limits, improper repair, or unauthorized modification. This WARRANTY is VOID if the unit shows evidence of having been tampered with or shows evidence of having been damaged as a result of excessive corrosion; or current, heat, moisture or vibration; improper specification; misapplication; misuse or other operating conditions outside of OMEGA's control. Components in which wear is not warranted, include but are not limited to contact points, fuses, and triacs.

OMEGA is pleased to offer suggestions on the use of its various products. However, OMEGA neither assumes responsibility for any omissions or errors nor assumes liability for any damages that result from the use of its products in accordance with information provided by OMEGA, either verbal or written. OMEGA warrants only that the parts manufactured by the company will be as specified and free of defects. OMEGA MAKES NO OTHER WARRANTIES OR REPRESENTATIONS OF ANY KIND WHATSOEVER, EXPRESSED OR IMPLIED, EXCEPT THAT OF TITLE, AND ALL IMPLIED WARRANTIES INCLUDING ANY WARRANTY OF MERCHANTABILITY AND FITNESS FOR A PARTICULAR PURPOSE ARE HEREBY DISCLAIMED. LIMITATION OF LIABILITY: The remedies of purchaser set forth herein are exclusive, and the total liability of OMEGA with respect to this order, whether based on contract, warranty, negligence, indemnification, strict liability or otherwise, shall not exceed the purchase price of the component upon which liability is based. In no event shall OMEGA be liable for consequential, incidental or special damages.

CONDITIONS: Equipment sold by OMEGA is not intended to be used, nor shall it be used: (1) as a "Basic Component" under 10 CFR 21 (NRC), used in or with any nuclear installation or activity; or (2) in medical applications or used on humans. Should any Product(s) be used in or with any nuclear installation or activity, medical application, used on humans, or misused in any way, OMEGA assumes no responsibility as set forth in our basic WARRANTY/DISCLAIMER language, and, additionally, purchaser will indemnify OMEGA and hold OMEGA harmless from any liability or damage whatsoever arising out of the use of the Product(s) in such a manner.

RETURN REQUESTS/INQUIRIES

Direct all warranty and repair requests/inquiries to the OMEGA Customer Service Department. BEFORE RETURNING ANY PRODUCT(S) TO OMEGA, PURCHASER MUST OBTAIN AN AUTHORIZED RETURN (AR) NUMBER FROM OMEGA'S CUSTOMER SERVICE DEPARTMENT (IN ORDER TO AVOID PROCESSING DELAYS). The assigned AR number should then be marked on the outside of the return package and on any correspondence.

The purchaser is responsible for shipping charges, freight, insurance and proper packaging to prevent breakage in transit.

FOR **WARRANTY** RETURNS, please have the following information available BEFORE contacting OMEGA:

1. Purchase Order number under which the product was PURCHASED,
2. Model and serial number of the product under warranty, and
3. Repair instructions and/or specific problems relative to the product.

FOR **NON-WARRANTY** REPAIRS, consult OMEGA for current repair charges. Have the following information available BEFORE contacting OMEGA:

1. Purchase Order number to cover the COST of the repair,
2. Model and serial number of the product, and
3. Repair instructions and/or specific problems relative to the product.

OMEGA's policy is to make running changes, not model changes, whenever an improvement is possible. This affords our customers the latest in technology and engineering.

OMEGA is a registered trademark of OMEGA ENGINEERING, INC.

© Copyright 2013 OMEGA ENGINEERING, INC. All rights reserved. This document may not be copied, photocopied, reproduced, translated, or reduced to any electronic medium or machine-readable form, in whole or in part, without the prior written consent of OMEGA ENGINEERING, INC.

Where Do I Find Everything I Need for Process Measurement and Control? **OMEGA...Of Course!** *Shop online at omega.comSM*

TEMPERATURE

- ☑ Thermocouple, RTD & Thermistor Probes, Connectors, Panels & Assemblies
- ☑ Wire: Thermocouple, RTD & Thermistor
- ☑ Calibrators & Ice Point References
- ☑ Recorders, Controllers & Process Monitors
- ☑ Infrared Pyrometers

PRESSURE, STRAIN AND FORCE

- ☑ Transducers & Strain Gages
- ☑ Load Cells & Pressure Gages
- ☑ Displacement Transducers
- ☑ Instrumentation & Accessories

FLOW/LEVEL

- ☑ Rotameters, Gas Mass Flowmeters & Flow Computers
- ☑ Air Velocity Indicators
- ☑ Turbine/Paddlewheel Systems
- ☑ Totalizers & Batch Controllers

pH/CONDUCTIVITY

- ☑ pH Electrodes, Testers & Accessories
- ☑ Benchtop/Laboratory Meters
- ☑ Controllers, Calibrators, Simulators & Pumps
- ☑ Industrial pH & Conductivity Equipment

DATA ACQUISITION

- ☑ Data Acquisition & Engineering Software
- ☑ Communications-Based Acquisition Systems
- ☑ Plug-in Cards for Apple, IBM & Compatibles
- ☑ Data Logging Systems
- ☑ Recorders, Printers & Plotters

HEATERS

- ☑ Heating Cable
- ☑ Cartridge & Strip Heaters
- ☑ Immersion & Band Heaters
- ☑ Flexible Heaters
- ☑ Laboratory Heaters

ENVIRONMENTAL MONITORING AND CONTROL

- ☑ Metering & Control Instrumentation
- ☑ Refractometers
- ☑ Pumps & Tubing
- ☑ Air, Soil & Water Monitors
- ☑ Industrial Water & Wastewater Treatment
- ☑ pH, Conductivity & Dissolved Oxygen Instruments