

User's Guide

<http://www.omega.com>
e-mail: info@omega.com

**GPIB HARDWARE MANUAL
FOR USE WITH
PCI-GPIB, ISA-GPIB**

CHAPTER ONE: INTRODUCTION	1
1.1 HISTORY	1
1.2 GPIB SYSTEM DESCRIPTION	1
1.2.1 Talkers, Listeners, and Controllers	1
1.2.2 GPIB Electrical Signal Configuration	2
1.2.3 Connection Configurations	3
CHAPTER TWO: INSTALLATION	5
2.1 PCI-GPIB	5
2.2 ISA-GPIB	6
2.3 ISA-GPIB/LC	8
2.4 PCM-GPIB	10
2.4.1 Windows 95	11
2.4.2 Windows 3.1	11
2.5 PC104-GPIB	12
2.6 CPCI-GPIB	14

Chapter One: INTRODUCTION

1.1 HISTORY

The GPIB (General Purpose Interface Bus) has become the worldwide standard for connecting instruments to computers. Invented in the 1960s by Hewlett Packard and originally designated as HPIB, the bus specification was eventually adopted by a wide variety of both instrument and computer manufacturers. The original specification was documented and sanctioned by the Institute of Electrical and Electronic Engineers as IEEE-488.

The advent of the inexpensive and powerful personal computer has driven the GPIB market through explosive growth. As GPIB bus usage expanded, there arose the need for some additional capability and standardization, so in 1987, IEEE-488.2 was adopted. IEEE-488.2 was revised/amended in 1992 and represents the current GPIB specification. The new specification provides some standardization among compliant instruments. This standardization greatly simplifies the job of the GPIB system designer since 488.2 compliant instruments share common programming conventions.

1.2 GPIB SYSTEM DESCRIPTION

1.2.1 Talkers, Listeners, and Controllers

A GPIB device can be a **Talker**, **Listener**, and/or **Controller**. As the name implies a Talker sends data to one or more Listeners, a Listener accepts data from a Talker and a Controller manages the flow of information over the bus. A GPIB Digital Voltmeter is acting as a Listener as its input configurations and ranges are set, and then as a Talker when it actually sends its readings to the computer.

The Controller is in charge of all communications over the bus. The Controller's job is to make sure only one device tries to talk at a time, and make sure the correct Listeners are paying attention when the Talker talks. Each GPIB system has a single system controller. The system controller is ultimately in charge of the bus, and is in control as the bus is powered up. There can be more than one Controller on the bus and the System Controller can pass active control to another controller capable device, though only one can be Controller In Charge at a given time. The GPIB board is usually designated as the System Controller.

1.2.2 GPIB Electrical Signal Configuration

The GPIB is an 8-bit parallel data transfer bus. In addition to the 8 data bits, the bus carries three handshaking lines and five GPIB specific management and control lines. The remainder of the standard 24 pin GPIB cable is used for the cable shield, signal grounds and returns. The GPIB connector pin-out is shown in the diagram below:

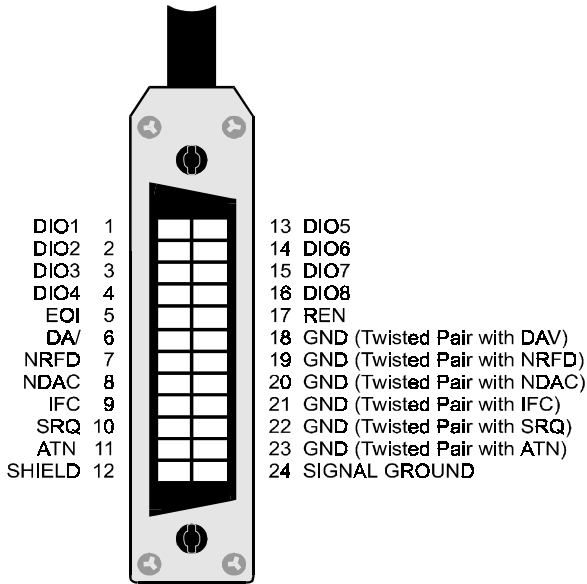

Standard GPIB Cable/Connector

DATA LINES

DIO1 through DIO8 are the data transfer bits. Most GPIB systems send 7-bit data and use the eight bit as a parity or disregard it entirely

HANDSHAKING LINES

There are three handshaking lines that control the data transfer between devices.

NRFD (Not Ready For Data): this bit is used to indicate the readiness (or lack thereof) of a device to accept data

DAV (Data Valid): bit is used to indicate to receiving devices that data has been placed on the bus and is available to read.

NDAC (Not Data Accepted): is asserted by the receiving device to indicate that data has been read and may now be removed from the bus.

SYSTEM MANAGEMENT LINES

ATN (Attention): is used by the controller to specify how data on the DIO lines is interpreted and which devices must respond to the data

IFC (Interface Clear): is used by the system controller to place the entire system in a known quiescent (Cleared) state and to assert itself as Controller In Charge (CIC).

SRQ (Service Request): is used by a device on the bus to indicate the need for attention and requests an interrupt of the current event sequence.

REN (Remote Enable): is used by the controller in conjunction with other messages to place a device on the bus into either remote or local mode

EOI (End or Identify): Is used by Talkers to indicate the end of a message string, or is used by the Controller to command a polling sequence.

1.2.3 Connection Configurations

The GPIB specification is quite definitive regarding the number of devices and cable lengths allowed in a GPIB system. There can be no more than 15 devices on a single contiguous GPIB bus. Larger systems are possible by installing additional GPIB interface boards in your computer

The maximum, total length of all cables on a single GPIB system is 20 meters. In addition, cable length between consecutive devices may be no greater than 4 meters, and average cable length must be 2 meters or less. Stated another way, the total cable length (in meters) in the system may not be longer than 2 times the number of devices (up to 20 meters). Longer length systems are possible, but only with the use of a GPIB extender card.

In addition to the above rules, at least two thirds of all devices on the bus should be powered on for proper operation.

Keeping the above constraints in mind, there is no limitation on the actual connection scheme used to connect the GPIB devices together. Star, Linear or any combination of both may be used. These are shown in the following diagrams.

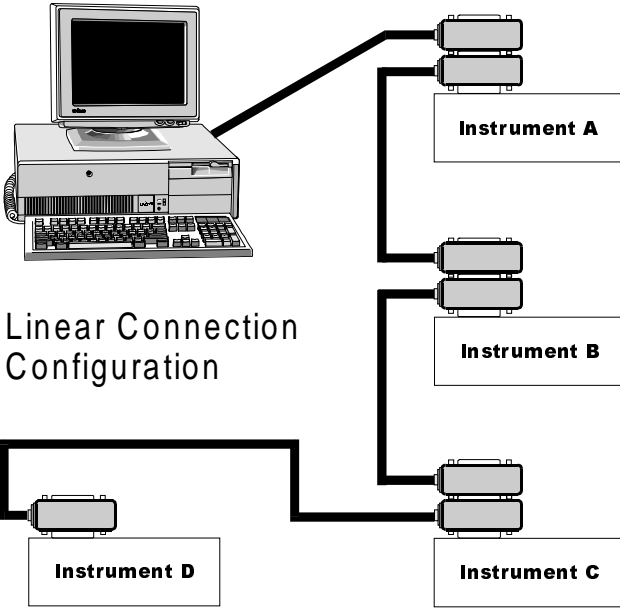

Linear Connection Configuration

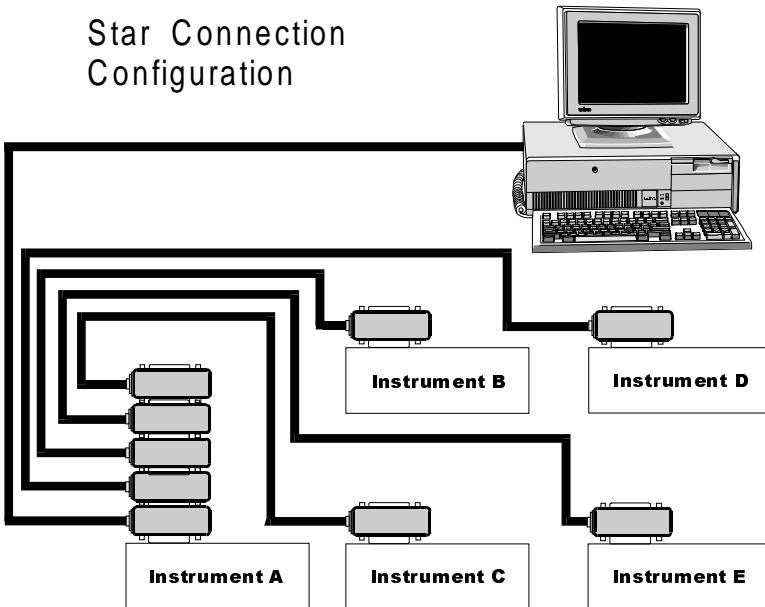

Star Connection Configuration

Chapter Two: INSTALLATION

The following sections describe the hardware installation procedure for GPIB boards. After hardware installation, please refer to your GPIB software installation guide for additional setup and operation details.

2.1 PCI-GPIB

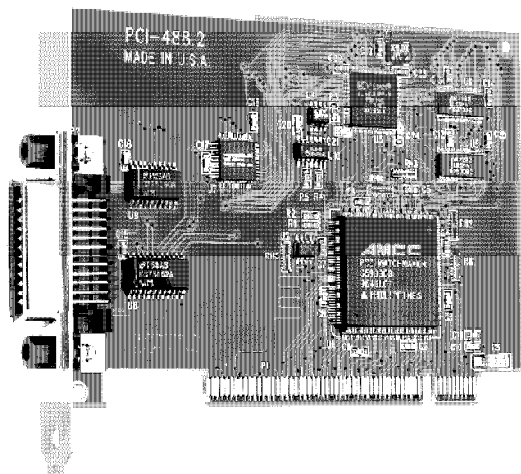

The PCI-GPIB board is completely plug and play. To install this board into your system follow the simple steps shown below.

1. Turn your computer off
2. Open your computer case
3. Insert the PCI-GPIB into any available PCI slot
4. Put your computer's case back on.
5. Turn your computer back on, and follow the instructions in the GPIB software manual you received with your board.

2.2 ISA-GPIB

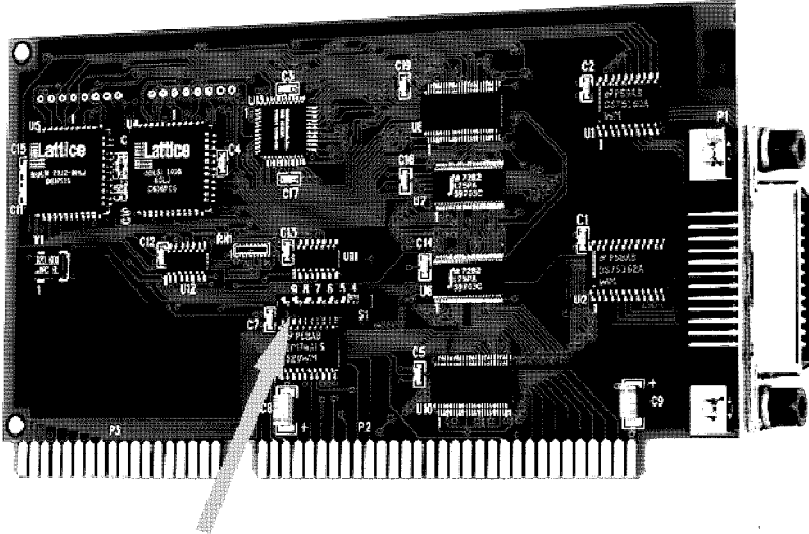

Base Address Switch

The only hardware configuration required prior to installing the ISA-GPIB/LC is setting the board's Base Address switch. The location of the Base Address switch is shown in the photograph above, while the switch itself is shown in the diagram on the following page.

Most computers will have Base Address 300 Hex (768 decimal) free and the default setting of the board is 300 Hex. If there is already a board in your system using address 300 HEX (768 Decimal), you will have to change the board's base address prior to installing it in your computer. Other typically free addresses include 310 Hex and 330 Hex.

The following diagram shows the base address in its default 300 Hex setting.

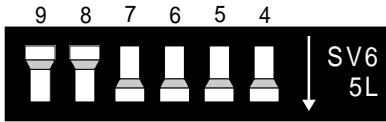

The address values corresponding to each of the switches are shown in the following table.

	<i>Hex</i>	<i>Dec.</i>	
<u>Switch</u>	<u>Value</u>	<u>Value</u>	<u>Default</u>
9	200	512	up (200 Hex)
8	100	256	up (100 Hex)
7	80	128	down (0 Hex)
6	40	64	down (0 Hex)
5	20	32	down (0 Hex)
4	10	16	down (0 Hex)

	total	300 Hex	

Note: On this base address switch, *Up is on, Down is off*. **This configuration is the opposite of most ISA based data acquisition boards.**

2.3 ISA-GPIB/LC

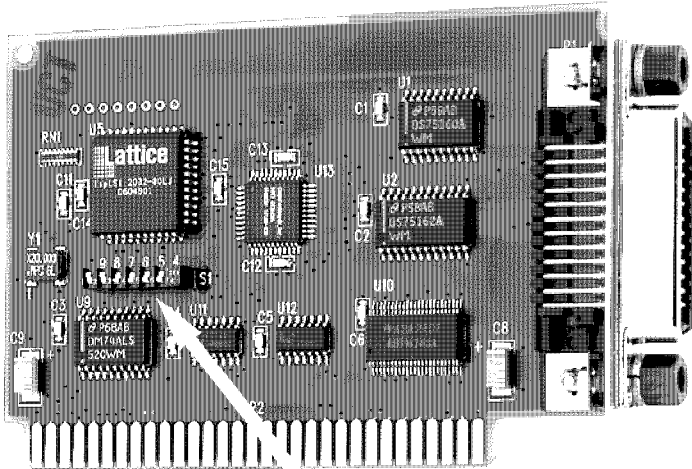

Address Switch

The only hardware configuration required prior to installing the ISA-GPIB/LC is setting the board's Base Address switch. The location of the Base Address switch is shown in the photograph above, while the switch itself is shown in the diagram on the following page.

Most computers will have Base Address 300 Hex (768 decimal) free and the default setting of the board is 300 Hex. If there is already a board in your system using address 300 HEX (768 Decimal), you will have to change the board's base address prior to installing it in your computer. Other typically free addresses include 310 Hex and 330 Hex.

The following diagram shows the base address in its default 300 Hex setting.

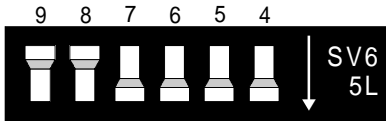

The address values corresponding to each of the switches are shown in the following table.

	<i>Hex</i>	<i>Dec.</i>	
<u>Switch</u>	<u>Value</u>	<u>Value</u>	<u>Default</u>
9	200	512	up (200 Hex)
8	100	256	up (100 Hex)
7	80	128	down (0 Hex)
6	40	64	down (0 Hex)
5	20	32	down (0 Hex)
4	10	16	down (0 Hex)

	total	300 Hex	

Note: On this base address switch, *Up is on, Down is off*. **This configuration is the opposite of most ISA based data acquisition boards.**

2.4 PCM-GPIB

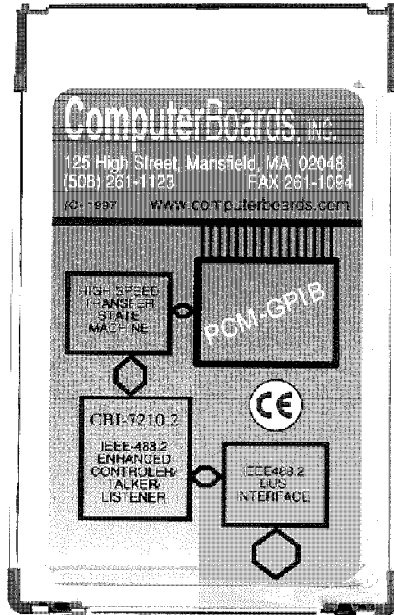

The installation procedure is different for Windows 95 and DOS/Windows 3.1. These procedures are described below:

2.4.1 Windows 95

The PCM-GPIB board is completely plug and play. There are no switches or jumpers to set prior to installation in your computer. Simply follow the steps shown below to install you PCM-GPIB hardware. Once your hardware is installed, please refer to the GPIB-488.2 software manual.

1. Start Windows 95
2. Insert the card into a free PC Card/PCMCIA slot. You do not have to turn the computer off. The system is designed for power on installation.
3. Windows 95 will automatically detect the card and depending on the version of Windows 95 you have, you will either see a *New Hardware Found* dialog box or a *Update Device Driver Wizard* box.
4. Insert PCM-GPIB Disk 1 into your A drive and follow the instructions provided by the dialog box/wizard.

If no *New Hardware Found* dialog box appears, check that you computer's 32-bit PCMCIA drivers are enabled. This can be checked using the following Windows 95 sequence. **Start>Settings>Control Panel>System** and look in **Performance** section. It should read 32-bit. If not, enable 32-bit, shut down your computer and try the above procedure again.

2.4.2 Windows 3.1

Most users are now installing boards on systems with at least Windows 95 operating systems. However, if you wish to install the PCM-GPIB board in a machine running Windows 3.1 and/or DOS, you will need to use the DOS based Card & Socket services routine. This is included with most newer computers. However, if you need to purchase these routines, they are available as part number PCM-C&SS from ComputerBoards for a nominal price. To run the C&SS installation routines, place the PCM-C&SS disk in drive a:, from your boot drive (usually C:) type *A:Install* and hit enter. Then simply follow the instructions on your screen.

The PCM-GPIB hardware is completely plug and play. There are no switches or jumpers to set prior to installation in your computer. Once your hardware is installed, please refer to the GPIB-488.2 software manual.

2.5 PC104-GPIB

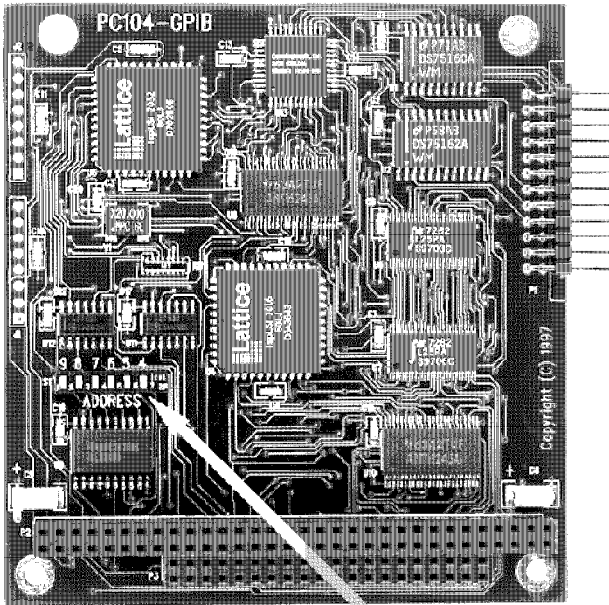

Base Address Switch

The only hardware configuration required prior to installing the ISA-GPIB/LC is setting the board's Base Address switch. The location of the Base Address switch is shown in the photograph above, while the switch itself is shown in the diagram on the following page.

Most computers will have Base Address 300 Hex (768 decimal) free and the default setting of the board is 300 Hex. If there is already a board in your system using address 300 HEX (768 Decimal), you will have to change the board's base address prior to installing it in your computer. Other typically free addresses include 310 Hex and 330 Hex.

The following diagram shows the base address in its default 300 Hex setting.

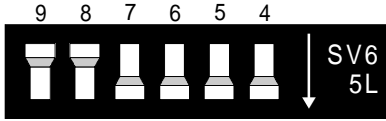

The address values corresponding to each of the switches are shown in the following table.

	<i>Hex</i>	<i>Dec.</i>	
<u>Switch</u>	<u>Value</u>	<u>Value</u>	<u>Default</u>
9	200	512	up (200 Hex)
8	100	256	up (100 Hex)
7	80	128	down (0 Hex)
6	40	64	down (0 Hex)
5	20	32	down (0 Hex)
4	10	16	down (0 Hex)

	total	300 Hex	

Note: On this base address switch, *Up is on, Down is off*. **This configuration is the opposite of most PC104 based data acquisition boards.**

2.6 CPCI-GPIB

The CPCI-GPIB board is completely plug and play. To install this board into your system follow the simple steps shown below.

1. Turn your computer off
2. Open your computer front panel (if enclosed)
3. Insert the CPCI-GPIB into any available 3U CPCI slot
4. Put your computer's case back on (optional).
5. Turn your computer back on, and follow the instructions in the GPIB software manual you received with your board.

EC Declaration of Conformity

ISA-GPIB	Computer to GPIB interface
ISA-GPIB/LC	Computer to GPIB interface
PCI-GPIB	Computer to GPIB interface
PC104-GPIB	Computer to GPIB interface
PCM-GPIB	Computer to GPIB interface
CPCI-GPIB	Computer to GPIB interface

Part Number	Description
-------------	-------------

to which this declaration relates, meets the essential requirements, is in conformity with, and CE marking has been applied according to the relevant EC Directives listed below using the relevant section of the following EC standards and other normative documents:

EU EMC Directive 89/336/EEC: Essential requirements relating to electromagnetic compatibility.

EU 55022 Class B: Limits and methods of measurements of radio interference characteristics of information technology equipment.

EN 50082-1: EC generic immunity requirements.

IEC 801-2: Electrostatic discharge requirements for industrial process measurement and control equipment.

IEC 801-3: Radiated electromagnetic field requirements for industrial process measurements and control equipment.

IEC 801-4: Electrically fast transients for industrial process measurement and control equipment.

Carl Haapaoja, Director of Quality Assurance