



REMOTE PROBE HUMIDITY/ TEMPERATURE TRANSMITTER SERIES

Installation & Operation Instructions

Phone: 1-888-967-5224
Website: workaci.com

GENERAL INFORMATION

The A/TT Remote Probe Series sensors and transmitters are single point sensors that output 4-20 mA with an optional voltage signal output of 1-5VDC or 2-10VDC signal. The sensor is designed for use with electronic controllers in commercial heating and cooling building management systems. All A/TT temperature transmitters can be powered from either an unregulated or regulated 8.5-32 VDC power supply.

The A/RH Remote Probe Series sensor is a relative humidity transmitter that can be powered with either an AC or DC supply voltage. The RH Remote Probe transmitter is field selectable with a 4-20 mA, 0-5 VDC, or 0-10 VDC output signal that is equivalent to 0 to 100% RH. All RH units are shipped from the factory set to 4-20 mA output.

FIGURE 1: ENCLOSURE DIMENSIONS

NEMA 4X (-4X)

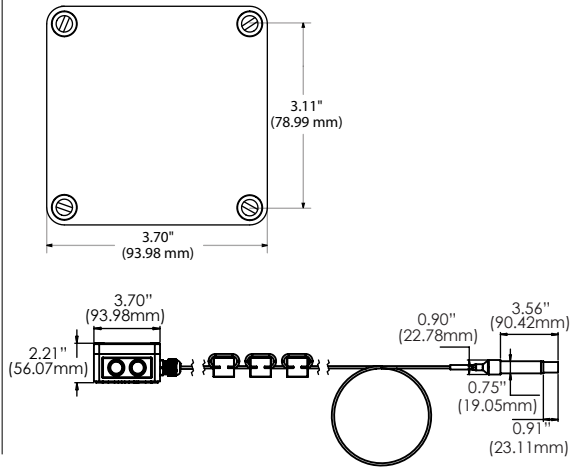

For optimal readings, follow these tips:

- Do not install on external walls.
- Avoid air registers, diffusers, vents, and windows.
- Eliminate and seal all wall and conduit penetrations. Air migration from wall cavities may alter temperature readings.
- Do not install near heat sources. eg: lamps, radiators, direct sunlight, copiers, chimney walls, walls concealing hot-water pipes.

MOUNTING INSTRUCTIONS

Remote Probe sensors may be mounted using a 3/4" mounting clip(not included) on walls or with cable ties. The sensor should be mounted in an area where air circulation is well mixed and not blocked by obstructions.

The RH Remote Probe includes a Black Rubber Cap that fits over the sensor filter. This cap should be placed on the sensor filter during wet/wash down processes. **The cap must be removed for normal operation.**

TRANSMITTER MOUNTING

Attach the base directly to the wall by first drilling pilot holes for the mounting screws. Alternatively, you may refer to the dimensions listed in **FIGURE 1** (top) to measure out.

SENSOR MOUNTING

To fix the probe on a wall, ACI recommends a height of 48-60" (1.2-1.5 m) off the ground and at least 1.5' (0.5 m) from the adjacent wall. Slide the sensor probe through the mounting clip(not included) - see **FIGURE 2** (p. 2). Drill a screw through the socket and tighten to the wall. Refer to **Wiring Instructions** (p. 2-4) to make necessary connections.



WIRING INSTRUCTIONS



PRECAUTIONS

- RH Transmitter can be powered by VAC or VDC.
- Temperature transmitter is powered by 24 VDC only.
- Remove power before wiring. Never connect or disconnect wiring with power applied.
- Shielding - When using a shielded cable, ground the shield at the Transmitter ONLY. Do NOT ground the shield at the controller. Grounding both ends can cause a ground loop. The shield needs to be terminated into the Com terminal.
- It is recommended you use an isolated UL-listed class 2 transformer when powering the unit with 24 VAC. Failure to wire the devices with the correct polarity when sharing transformers may result in damage to any device powered by the shared transformer.
- If the 24 VDC or 24VAC power is shared with devices that have coils such as relays, solenoids, or other inductors, each coil must have an MOV, DC/AC Transorb, Transient Voltage Suppressor (ACI Part: 142583), or diode placed across the coil or inductor. The cathode, or banded side of the DC Transorb or diode, connects to the positive side of the power supply. Without these snubbers, coils produce very large voltage spikes when de-energizing that can cause malfunction or destruction of electronic circuits.

TEMPERATURE

The PG11 cord grip cap is shipped loosely tightened. Make sure that is loose when you open the cover. This is the cord grip that the remote sensor goes to.

Open the cover of the enclosure. The temperature transmitter is located on the bottom of the enclosure. ACI recommends 16 to 26 AWG twisted pair wires or shielded cable for all transmitters.

FIGURE 2: MOUNTED ASSEMBLY

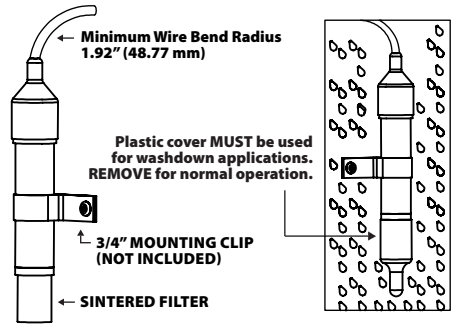

FIGURE 3: PRINTED CIRCUIT BOARDS

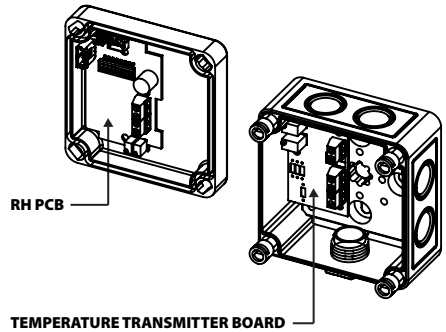
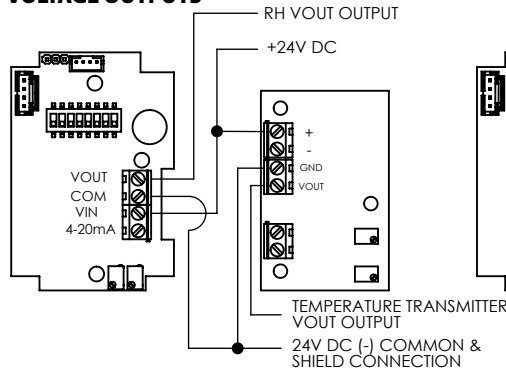
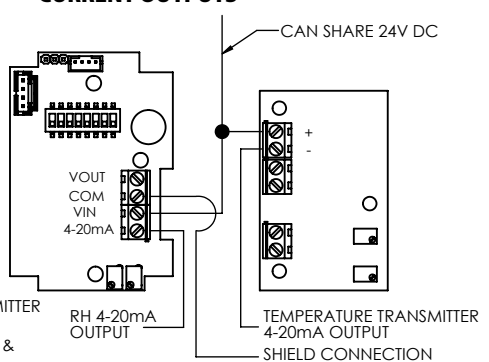

FIGURE 4: SHARED POWER CONNECTIONS and ANALOG OUTPUTS

VOLTAGE OUTPUTS



CURRENT OUTPUTS



WIRING INSTRUCTIONS (Continued)

TEMPERATURE (Continued)

Twisted pair may be used for 2-wire current output transmitters or 3-wire for voltage output. Refer to **FIGURE 5** (top) for wiring diagrams. All wiring must comply with local and National Electric Codes. All ACI TT and TTM temperature transmitters can be powered from either an unregulated or regulated 8.5 to 32VDC power supply. The TT and TTM DO NOT support an AC input. All TT and TTM temperature transmitters are reverse polarity protected. After wiring, attach the cover to the enclosure.

The minimum voltage at the transmitter power terminal is 8.5V after load resistor voltage drop.

- 249 Ω load resistor (1-5 VDC output) = 13.5 V min supply voltage
- 499 Ω load resistor (2-10 VDC output) = 18.5 V min supply voltage

Note: All RTD's are supplied with (2) or (3) flying lead wires. ACI's transmitters are supplied with a 2 pole terminal block for RTD sensor connections. When wiring a 3 wire RTD, connect the (2) common wires (same color) together into the same terminal block - see **FIGURE 4** (p.2).

TEMPERATURE - MULTIPLE CONNECTIONS

Several transmitters may be powered from the same supply as shown in **FIGURE 6** (bottom). Each transmitter draws 25mA; refer to the following equation to obtain the number of permissible transmitters: $[\# \text{ Transmitters}] = [\text{Current}] / (25 \text{ mA})$.

FIGURE 5: TEMPERATURE WIRING

STANDARD UNITS

CURRENT OUTPUT (4 to 20 mA)

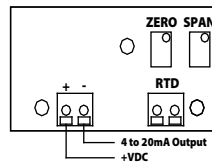

VOLTAGE OUTPUT (1-5 or 2-10 VDC)

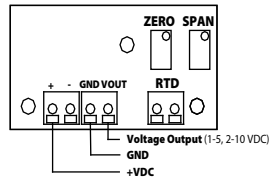

POTTED UNITS

CURRENT OUTPUT (4 to 20 mA)

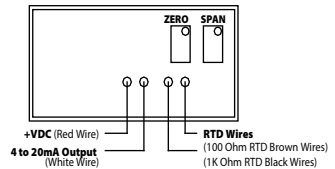

VOLTAGE OUTPUT (1-5 or 2-10 VDC)

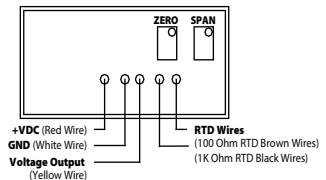
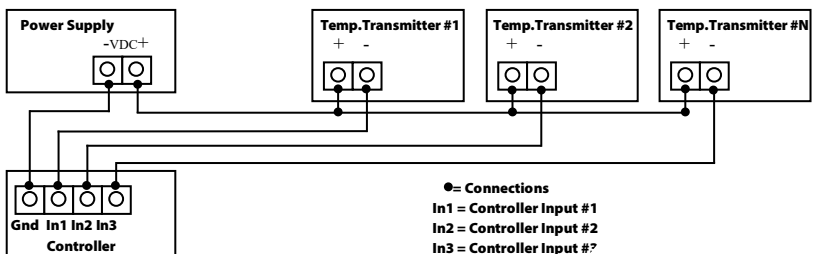

FIGURE 6: MULTIPLE TRANSMITTER CONNECTIONS



WIRING INSTRUCTIONS

(Continued)

RELATIVE HUMIDITY WIRING INSTRUCTIONS

Open the cover of the enclosure. The RH transmitter is located on the inside of the cover. ACI recommends 16 to 26 AWG twisted pair wires or shielded cable for all transmitters. Twisted pair may be used for 2-wire current output transmitters or 3-wire for voltage output. Refer to **FIGURE 7** (top) for wiring diagrams.

RH OUTPUT SIGNALS

Switches 6, 7, and 8 are used to set the RH output signal. Refer to **FIGURE 8** (bottom) for switch settings.

HUMIDITY REVERSE ACTING OUTPUT

The output is direct acting and can be changed to reverse acting mode. The output range stays the same but the corresponding RH value is opposite.

Example:

Direct Acting (DA)

0-10 V output mode,

0 V = 0% RH and 10 V =

100% RH

Reverse Acting (RA)

0-10 V output mode,

0 V = 100% and 10 V = 0%

To change the transmitter to reverse acting or back to direct acting, set switch 4 to ON to put the unit in setup mode. After switch 4 is on, turning switch 2 to ON will put the unit in direct/reverse acting mode. When switch 2 is set to ON, the output can be used to show if the unit is in direct or reverse acting mode. For direct acting, the output will be 1 V for 0-5 V, 2 V for 0-10 V, and 7.2 mA for 4-20 mA. For reverse acting the output will be 4 V for 0-5 V, 8 V for 0-10 V, and 16.8 mA for 4-20 mA.

With switches 2 and 4 ON, each time switch 5 is set to ON the output will change to reverse acting or direct acting. To reset the unit to the default setting, toggle both switches 5 and 6 ON then OFF while both switches 2 and 4 are ON. When all calibration is completed, remember to place the switches back into the positions that correspond to the output needed as shown in **FIGURE 8** (bottom).

RH CALIBRATION INSTRUCTIONS

Note: This is only a single point calibration. All transmitters are factory calibrated to meet/exceed published specifications. Field adjustment should not be necessary.

FIGURE 7: RH OUTPUT SIGNALS

2 WIRE CURRENT OUTPUT SIGNAL

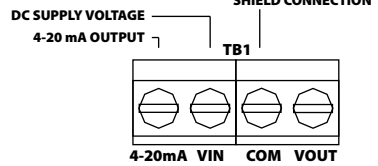

3 WIRE CURRENT OUTPUT SIGNAL

SUPPLY GROUND / SIGNAL COMMON / SHIELD CONNECTION

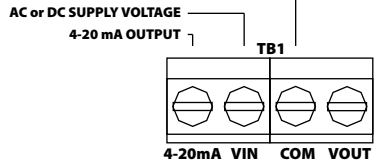

VOLTAGE OUTPUT SIGNAL

0-10 or 0-5 VDC OUTPUT SIGNAL

SUPPLY GROUND / SIGNAL COMMON / SHIELD CONNECTION

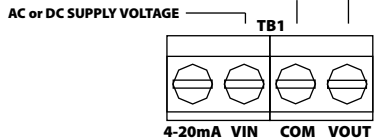
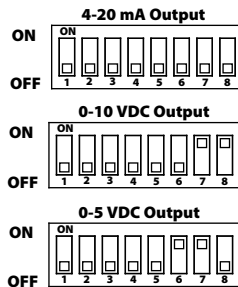

FIGURE 8: RH OUTPUT SWITCHES



RH CALIBRATION INSTRUCTIONS (Continued)

The dipswitch allows the user to calibrate the sensor through the software. Setting switch 4 ON will put the transmitter into setup mode allowing the increment and decrement to work. Once in setup mode, the output will change to 50% (2.5 V for 0-5 V, 5 V for 0-10 V, 12 mA for 4-20 mA). Each increment or decrement step will cause the output to change by 0.1 V for 0-5 V, 0.2 V for 0-10 V, and 0.32 mA for 4-20 mA in setup mode. This can be used to show the user how far offset the transmitter is. To see the starting point again set switch 1 ON. This will show the 50% output again. When the unit is out of setup mode the output will go back to RH output. The maximum offset is 10%. There can be a total of 20 increments.

Increment RH Output

This will shift the RH output linearly up in 0.5% steps. Switch 4 must be set to ON first. After switch 4 is on, each time switch 5 is set ON the RH output will increase by 0.5%. The increase goes into effect each time switch 5 is set to ON.

Decrement RH Output

This will shift the RH output linearly down in 0.5% steps. Switch 4 must be set to ON first. After switch 4 is on, each time switch 6 is set ON the RH output will decrease by 0.5%. The decrease goes into effect each time switch 6 is set to ON.

Reset RH Output

This will reset the RH output back to the original calibration. Switch 4 must be set to ON first. After switch 4 is on, toggle switches 5 and 6 ON then OFF. After 5 and 6 are OFF, slide switch 4 OFF. When all calibration is completed, remember to place the switches back into the positions that correspond to the output needed as shown in **FIGURE 8** (p. 4).

RH TEST INSTRUCTIONS

Test mode will make the transmitter output a fixed 0%, 50%, or 100% value. The sensor will not affect the transmitter output. This is used for troubleshooting or testing only.

Switches 1, 2, and 3 are used for test mode. The output will be a fixed 0%, 50%, or 100% signal that corresponds to the output selected with switches 6, 7, and 8. Refer to **FIGURE 9** (right) for switch settings.

FIGURE 9: RH SELECTION SWITCHES

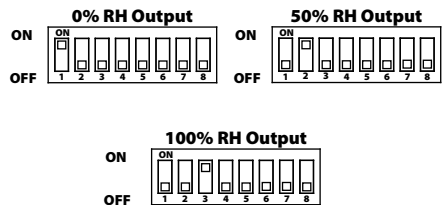

RH CONVERSION FORMULAS

	4-20 mA	0-5 VDC	0-10 VDC
Formula:	$((\text{mA signal}) - 4) / 0.16 = \text{percent RH}$	$[\text{VDC signal}] / 0.05 = \text{percent RH}$	$[\text{VDC signal}] / 0.10 = \text{percent RH}$
Example:	12 mA output signal $(12 - 4) / 0.16 = 50\% \text{ RH}$	1.25 vdc output signal $1.25 / 0.05 = 25\% \text{ RH}$	7.50 vdc output signal $7.50 / 0.10 = 75\% \text{ RH}$

WARRANTY

The ACI Remote Probe Series RH sensors are covered by ACI's Five (5) Year Limited Warranty, which is located in the front of ACI'S SENSORS & TRANSMITTERS CATALOG or can be found on ACI's website: www.workaci.com.

PRODUCT SPECIFICATIONS

CABLE & ENCLOSURE	
Minimum Cable Bend Radius:	1.92" (48.77 mm) or 10x the Cable Diameter
Cable Ratings Cable Jacket Material:	UL (CMP, CL3P, FPLP); CSA (CMP, FT6), Plenum Rated Polyvinyl Chloride (PVC)
Cable Operating Temperature Range:	32 to 167 °F (0 to 75 °C)
Enclosure Specifications: (Material, Flammability, Temp., NEMA/IP Ratings):	"-4X" Enclosure: ABS Plastic; UL94-V0; -40 to 140 °F (-40 to 60 °C)
Sensing Tube Material:	304 Series Stainless Steel
Filter Material:	304 Series Stainless Steel
RH TRANSMITTER	
RH Supply Voltage (Reverse Polarity Protected):	4-20 mA: 250 Ω Load: 15 - 40 VDC / 18 - 28 VAC 500 Ω Load: 18 - 40 VDC / 18 - 28 VAC 0-5 VDC: 12 - 40 VDC / 18 - 28 VAC 0-10 VDC: 18 - 40 VDC / 18 - 28 VAC
RH Supply Current (VA):	Voltage Output: 8 mA maximum (0.32 VA) Current Output: 24 mA maximum (0.83 VA)
RH Output Load Resistance:	4-20 mA: 700 Ω maximum 0-5 VDC or 0-10 VDC: 4 KΩ Minimum
RH Output Signal:	2-wire: 4 - 20 mA (Default) 3-wire: 0-5 or 0-10 VDC & 4 - 20 mA (Field Selectable)
RH Accuracy @ 77°F (25°C):	+/- 1% over 20% RH Range between 20 to 90% +/- 2%, 3%, or 5% from 10 to 95%
RH Measurement Range:	0-100%
Operating RH Range:	0 to 95% RH, non-condensing (Conformally Coated PCB's)
Operating Temperature Range:	-40 to 140 °F (-40 to 60 °C)
Storage Temperature Range:	-40 to 149 °F (-40 to 65 °C)
RH Stability Repeatability Sensitivity:	Less than 2% drift / 5 years 0.5% RH 0.1% RH
RH Response Time (T63):	20 Seconds Typical
RH Sensor Type:	Capacitive with Hydrophobic Filter
RH Transmitter Stabilization Time:	30 Minutes (Recommended time before doing accuracy verification)
RH Connections Wire Size:	Screw Terminal Blocks (Polarity Sensitive) 16 (1.31 mm ²) to 26 AWG (0.129 mm ²)
RH Terminal Block Torque Rating:	4.43 to 5.31 lb-in (0.5 to 0.6 Nm)
RH NIST Test Points:	Default Test Points: 3 Points (20%, 50% & 80%) or 5 Points (20%, 35%, 50%, 65% & 80%) 1% NIST Test Points: 5 Points within selected 20% Range (ie. 30%-50% are 30, 35, 40, 45 & 50)
TEMPERATURE TRANSMITTER	
TT Supply Voltage:	+8.5 to 32 VDC (Reverse Polarity Protected); 25 mA minimum
Supply Current:	250 Ω Load: +13.5 to 32 VDC 500 Ω Load: +18.5 to 32 VDC
TT Maximum Load Resistance:	(Terminal Voltage - 8.5 V) / 0.020 A
TT Output Signals:	2-Wire: 4-20 mA Current Output 3-Wire: 1-5 VDC/2-10 VDC Voltage Output
TT Calibrated Accuracy Linearity ¹:	T.Spans < 500 °F (260 °C): +/- 0.2% T.Spans > 500 °F (260 °C): +/- 0.5%
TT Temperature Drift ²:	T.Spans < 100 °F (38 °C): +/- 0.04%/°F T.Spans > 100 °F (38 °C): +/- 0.02%/°F
TTM100/TTM1K Certification Points:	3 Point NIST: 20, 50, 80% of span 5 Point NIST: 20, 35, 50, 65, & 80% of span
TT Warm Up Time:	10 Minutes +/- 0.1%
Warm Up Drift:	-40 to 185 °F (-40 to 85 °C)
Transmitter Operating Temperature/RH Range:	0 to 90% RH, non-condensing
Platinum RTD (PTC) Number Wires Wire Colors:	Two TT100 & TTM100: Brown/Brown TT1K & TTM1K: Black/Black
Platinum RTD Sensor Output @ 32°F (0°C):	A/TT100/TTM100 Series: 100 Ω A/TT1K/TTM1K Series: 1000 Ω
Platinum RTD Tolerance Class Accuracy:	+/- 0.06% Class A Tolerance Formula: +/- °C = (0.15 °C + (0.002 * t), where t is the absolute value of Temperature above or below 0°C in °C)
Platinum RTD Sensor Stability:	+/-0.03% after 1000 Hours @ 572 °F (300 °C)
Platinum RTD Response Time (63% Step Change):	8 Seconds nominal

Note ¹: A Transmitter is calibrated at 71°F (22°C) Nominal | **Note ²:** Temperature Drift is referenced to 71°F nominal calibration temperature

W.E.E.E. DIRECTIVE

At the end of their useful life the packaging and product should be disposed of via a suitable recycling centre. Do not dispose of with household waste. Do not burn.

TROUBLESHOOTING

HUMIDITY READING PROBLEM

No Reading

- Check that you have the correct supply voltage at the power terminal blocks.
- Check that wiring configurations and all DIP switch settings are as in **FIGURE 7** and **8**.
- Verify that the terminal screws are all connected tightly and that all of the wires are firmly in place.

Erratic readings

- Verify that all of the wires are terminated properly.
- Make sure that there is no condensation on the board.
- Check that the input power is clean. In areas of high RF interference or noise, shielded cable may be necessary to stabilize signal.

Inaccurate readings

- Verify proper mounting location to confirm no external factors (see mounting locations above).
- Check the output (voltage or current) against a highly accurate recently calibrated secondary reference. Measure RH at the location of the sensor using the secondary reference, then calculate the RH percentage using the **RH CONVERSION FORMULAS** (p. 5). Compare the calculated output to reference.
- If the sensor is brand new, leave the sensor powered for at least 30 minutes to stabilize.
- If you suspect that the transmitter is not reading within the specified tolerance, please contact ACI for further assistance.

TEMPERATURE PROBLEM

No Reading

- No power to board - check voltage at power terminal - should be between +8.5 and 32 VDC.

Reading too Low

- RTD wires shorted. Disconnect wires from terminal block and check with ohmmeter. Reading should be close to 100 Ω or 1 K Ω .
- RTD Improper range of transmitter (too low). Check current or voltage - should be between 4-20 mA, 1-5 V, or 2-10 V.

Reading too High

- RTD opened. Disconnect sensor wires from terminal block and check with ohmmeter. Reading should be close to 100 Ω or 1 K Ω .
- Improper range of transmitter (too high). Check current or voltage - should be between 4-20 mA, 1-5 V, or 2-10 V.

Reading is Inaccurate

- **Sensor check:** Disconnect sensor wires from terminal block and check with ohmmeter. Compare the resistance reading to the Temperature vs Resistance curves located on ACI's website.
- **Transmitter check:** Make sure sensor wires are connected to terminal block. Determine that the proper output is being transmitted based on predetermined span:
 1. Go to ACI Website, Span to Output Page: <http://www.workaci.com/content/span-output>
 2. Enter the low end of the span
 3. Enter the high end of the span
 4. Click on the output of the transmitter. This will generate a span to output chart.
 5. Measure output of transmitter.
 6. Compare measured output to calculated output



NOTES



Automation Components, Inc.

2305 Pleasant View Road
Middleton, WI 53562

Phone: 1-888-967-5224

Website: workaci.com

