



MINI FIXED STATUS SWITCH SERIES

Installation & Operation Instructions
MCS, MSCS

Phone: 1-888-967-5224
Website: workaci.com

PRECAUTIONS

- This product is not intended to be used for Life or Safety applications.
- This product is not intended for use in any hazardous or classified locations.

HIGH VOLTAGE

- Disconnect and lock out all power sources before installation as severe injury or death may result from electrical shock due to contact with high voltage wires.

GENERAL INFORMATION

The Miniature Fixed Current Status™ Switches are designed for use in any AC current monitoring application in which you are looking for a fixed trip point to monitor the “Go/No Go” (On/Off) “Status” for a particular piece of equipment. The fixed current switches should be installed on the line side of the power to the motor, pump, compressor or other equipment. All of the miniature current switches are available in both solid and split-core versions in a smaller enclosure style than that of the A/CS2 and A/SCS2 Series fixed current switches rated for higher operating currents.

MOUNTING INSTRUCTIONS

Make sure that all installations are in compliance with all national and local electrical codes. Only qualified individuals that are familiar with codes, standards, and proper safety procedures for high-voltage installations should attempt installation. The current switches will not require external power, since the power for the current switch is induced from the conductor being monitored.

The A/MCS and A/MSCS Current Switches should be used on Insulated Conductors Only! The current switch may be mounted in any position using the (2) #8 x 3/4” Tek screws and the mounting holes in the base (see **Figure 2** (p.2)). Leave a minimum distance of 1” (3 cm) between the current switch and any other magnetic devices such as contactors and transformers.

FIGURE 1: DIMENSIONS

Solid-Core

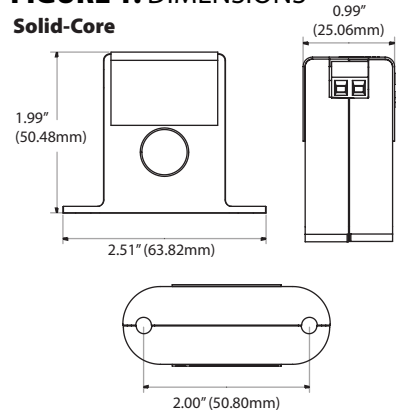

Split-Core

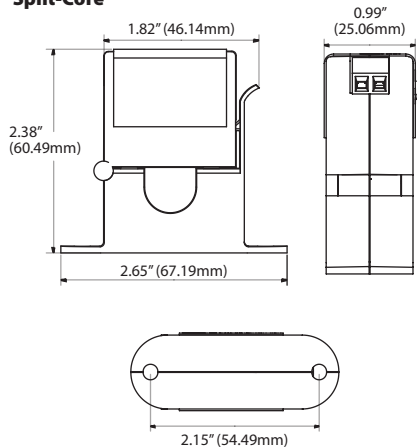
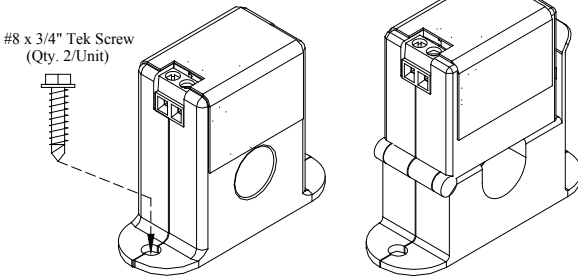

FIGURE 2: MOUNTING



WIRING INSTRUCTIONS

ACI recommends the use of a two conductor 16 to 22 AWG shielded cable or twisted pair copper wire only for all current switch applications. A maximum wire length of less than 30 meters (98.4 feet) should be used between the A/MCS and A/MSCS current switches and the Building Management System or controller.

Note: When using a shielded cable, be sure to connect only (1) end of the shield to ground at the controller.

Connecting both ends of the shield to ground may cause a ground loop. When removing the shield from the sensor end, make sure to properly trim the shield so as to prevent any chance of shorting. The current switch output terminals represent a solid-state switch for controlling both AC and DC loads and is not polarity sensitive. The recommended torque to be used on the terminal block connections is 0.67 Nm or 5.93 in-lbs.. The aperture (hole) size of the current switch is 0.53" (1.35 cm) and will accept a 1 AWG maximum wire diameter.

For applications in which the normal operating current is below the 0.20 Amps (A/MCS) or 0.55 Amps (A/MSCS) trip point (See **Figure 3** below), the conductor being monitored may be looped through the sensor 4 times giving you a total operating current of 4X the original current.

Example: A small fan operating at 0.2A should be wrapped through the sensor 4 times to give you a total operating current of 0.8Amps flowing through the A/MCS or A/MSCS.

FIGURE 3: WIRES THROUGH SENSORS

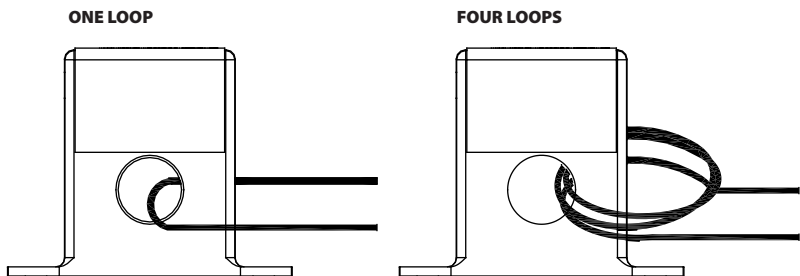

For applications in which the normal operating current is greater than 150 Amps or for conductor diameters larger than 0.530" (1.35 cm) in diameter, an external 5 Amp Current Transformer must be used as shown in **Figure 4** below.

Remember that the secondary of the 5A CT must be shorted together before the power may be turned onto the monitored device.

Example: For currents up to 600 Amps (and not below 70 Amps (A/MCS-A) or 95 Amps (A/MSCS-A), where Current Transformer (C.T.) secondary falls below 1 Amp use a 600:5 ratio C.T. as shown:

FIGURE 4: CURRENT TRANSFORMER

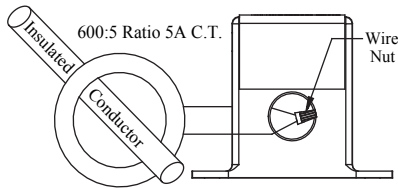
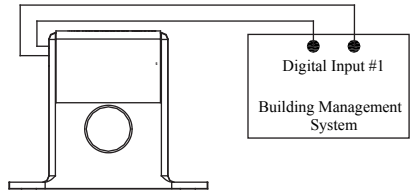

FIGURE 5: DIGITAL CIRCUIT



APPLICATION EXAMPLES

See **Figure 5** (p.3) and **Figure 6** (p.3) for two different current switch applications. **Figure 5** (p.3) is showing the use of the Mini Go/No Go Current Switch as a Digital Input to your BAS/PLC Controller. **Figure 6** (p.3) shows a Mini Go/No/Go Current Switch in conjunction with a Contactor to control an exhaust fan.

Note: The ACI Mini Fixed Go/No Go Current switches(MCS & MSCS Series) are only rated at 0.5A Continuous @ 36 VAC/VDC. These switches must use an additional Contactor if controlling motor/fans.

FIGURE 6: MOTOR/FAN CONTROL

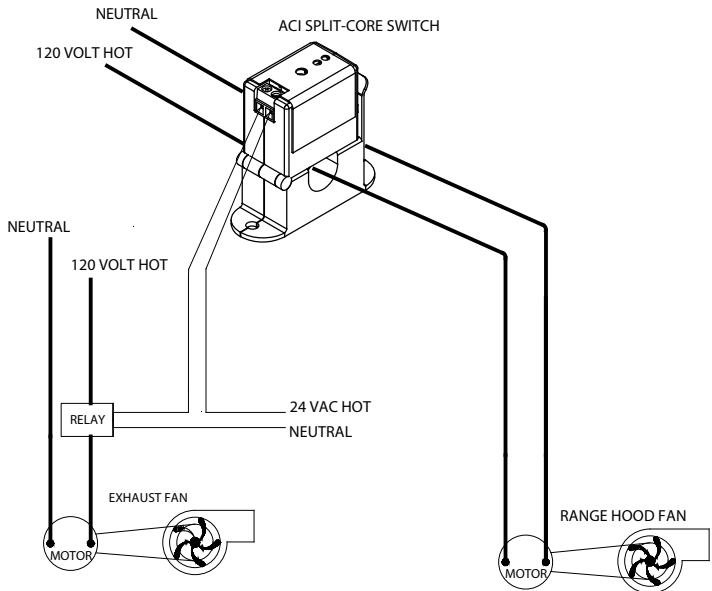

TROUBLESHOOTING

PROBLEM	SOLUTION(S)
Current switch didn't activate (Test #1)	Disconnect the wires from the current switch output. Measure the resistance across the contacts with an Ohmmeter. See Standard Ordering Table (p.5) for the actual resistance readings for an open or closed switch reading.
Current switch didn't activate (Test #2)	Verify that the current flowing in the conductor being monitored is above the fixed trip point as listed in the operating specifications. If the sensor is monitoring less than the fixed trip point, see Figure 3 .

ACI Model #	Resistance if switch open	Resistance if switch closed
A/MCS	Greater than 1 Meg ohms	Approximately 0.2 ohms
A/MSCS	Greater than 1 Meg ohms	Approximately 0.2 ohms

WARRANTY

The ACI Current Switch Series are covered by ACI's Five (5) Year Limited Warranty, which is located in the front of ACI'S SENSORS & TRANSMITTERS CATALOG or can be found on ACI's website: www.workaci.com.

W.E.E.E. DIRECTIVE

At the end of their useful life the packaging and product should be disposed of via a suitable recycling centre. Do not dispose of with household waste. Do not burn.



PRODUCT SPECIFICATIONS

SENSOR NON-SPECIFIC INFORMATION	
Monitored Current Type:	AC Current
Maximum AC Voltage:	600 VAC
Operating Frequency Range:	50/60 kHz
Core Style:	Solid-Core and Split-Core Versions available (See Ordering Grid)
Sensor Power:	Induced from the Monitored Conductor (Insulated Conductors only)
Amperage Range:	See Ordering Grid
Isolation Voltage:	2200 VAC
Trip Point Style Trip Point:	Fixed Trip Point See Ordering Grid
Contact Type:	Normally-Open "N/O"
"Status" Contact Rating:	0.5A @ 36 VAC/VDC
"Status" Contact "On" Resistance "Off" Resistance:	< 0.5 Ohms (tripped) > 1 Meg Ohms (Open)
Response Time:	A/MCS: < 50 mS typical A/MSCS: < 40 mS typical
Aperture Size:	0.53" (13.46 mm)
Operating Temperature Range:	-22 to 140°F (-30 to 60°C)
Operating Humidity Range:	0 to 95%, non-condensing
Wiring Connections:	2 Position Screw Terminal Block (Not Polarity Sensitive)
Wire Size:	16 to 22 AWG (1.31 mm ² to 0.33 mm ²) Copper Wires only
Terminal Block Torque Rating:	4.43 to 5.31 in-lbs. (0.5 to 0.6 Nm)
Minimum Mounting Distance:	1" (2.6 cm) between current switch (Relays, Contactors, Transformers)
Pollution Degree:	2
Environmental:	Indoor

STANDARD ORDERING

Model #	Item #	Trip Point Type	N/O	Solid-Core	Split-Core	Amp Range	Trip Point	Contact Rating
A/MCS	117852	Fixed Trip Point	•	•		0 to 150A	0.20A or less	0.5A @ 36 VAC/VDC
A/MSCS	117853	Fixed Trip Point	•		•	0 to 150A	0.55A or less	0.5A @ 36 VAC/VDC



NOTES

NOTES



NOTES

NOTES



NOTES



Automation Components, Inc.
2305 Pleasant View Road
Middleton, WI 53562
Phone: 1-888-967-5224
Website: workaci.com