

WARRANTY/DISCLAIMER

OMEGA ENGINEERING, INC. warrants this unit to be free of defects in materials and workmanship for a period of **13 months** from date of purchase. OMEGA's WARRANTY adds an additional one (1) month grace period to the normal **one (1) year product warranty** to cover handling and shipping time. This ensures that OMEGA's customers receive maximum coverage on each product.

If the unit malfunctions, it must be returned to the factory for evaluation. OMEGA's Customer Service Department will issue an Authorized Return (AR) number immediately upon phone or written request. Upon examination by OMEGA, if the unit is found to be defective, it will be repaired or replaced at no charge. OMEGA's WARRANTY does not apply to defects resulting from any action of the purchaser, including but not limited to mishandling, improper interfacing, operation outside of design limits, improper repair, or unauthorized modification. This WARRANTY is VOID if the unit shows evidence of having been tampered with or shows evidence of having been damaged as a result of excessive corrosion; or current, heat, moisture or vibration; improper specification; misapplication; misuse or other operating conditions outside of OMEGA's control. Components in which wear is not warranted, include but are not limited to contact points, fuses, and triacs.

OMEGA is pleased to offer suggestions on the use of its various products. However, OMEGA neither assumes responsibility for any omissions or errors nor assumes liability for any damages that result from the use of its products in accordance with information provided by OMEGA, either verbal or written. OMEGA warrants only that the parts manufactured by the company will be as specified and free of defects. OMEGA MAKES NO OTHER WARRANTIES OR REPRESENTATIONS OF ANY KIND WHATSOEVER, EXPRESSED OR IMPLIED, EXCEPT THAT OF TITLE, AND ALL IMPLIED WARRANTIES INCLUDING ANY WARRANTY OF MERCHANTABILITY AND FITNESS FOR A PARTICULAR PURPOSE ARE HEREBY DISCLAIMED. LIMITATION OF LIABILITY: The remedies of purchaser set forth herein are exclusive, and the total liability of OMEGA with respect to this order, whether based on contract, warranty, negligence, indemnification, strict liability or otherwise, shall not exceed the purchase price of the component upon which liability is based. In no event shall OMEGA be liable for consequential, incidental or special damages.

CONDITIONS: Equipment sold by OMEGA is not intended to be used, nor shall it be used: (1) as a "Basic Component" under 10 CFR 21 (NRC), used in or with any nuclear installation or activity; or (2) in medical applications or used on humans. Should any Product(s) be used in or with any nuclear installation or activity, medical application, used on humans, or misused in any way, OMEGA assumes no responsibility as set forth in our basic WARRANTY/DISCLAIMER language, and, additionally, purchaser will indemnify OMEGA and hold OMEGA harmless from any liability or damage whatsoever arising out of the use of the Product(s) in such a manner.

RETURN REQUESTS/INQUIRIES

Direct all warranty and repair requests/inquiries to the OMEGA Customer Service Department. BEFORE RETURNING ANY PRODUCT(S) TO OMEGA, PURCHASER MUST OBTAIN AN AUTHORIZED RETURN (AR) NUMBER FROM OMEGA'S CUSTOMER SERVICE DEPARTMENT (IN ORDER TO AVOID PROCESSING DELAYS). The assigned AR number should then be marked on the outside of the return package and on any correspondence.

FOR **WARRANTY** RETURNS, please have the following information available BEFORE contacting OMEGA:

1. Purchase Order number under which the product was PURCHASED,
2. Model and serial number of the product under warranty, and
3. Repair instructions and/or specific problems relative to the product.

FOR **NON-WARRANTY** REPAIRS, consult OMEGA for current repair charges. Have the following information available BEFORE contacting OMEGA:

1. Purchase Order number to cover the COST of the repair or calibration,
2. Model and serial number of the product, and
3. Repair instructions and/or specific problems relative to the product.

OMEGA's policy is to make running changes, not model changes, whenever an improvement is possible. This affords our customers the latest in technology and engineering.

OMEGA is a trademark of OMEGA ENGINEERING, INC.

© Copyright 2018 OMEGA ENGINEERING, INC. All rights reserved. This document may not be copied, photocopied, reproduced, translated, or reduced to any electronic medium or machine-readable form, in whole or in part, without the prior written consent of OMEGA ENGINEERING, INC.

5

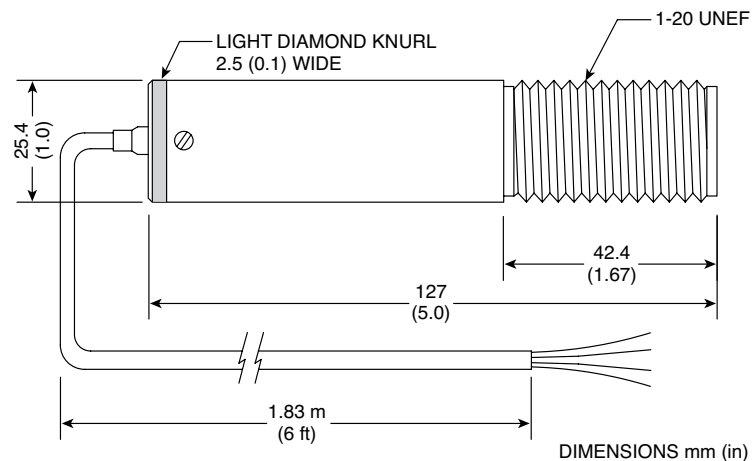

Stainless Steel Housing

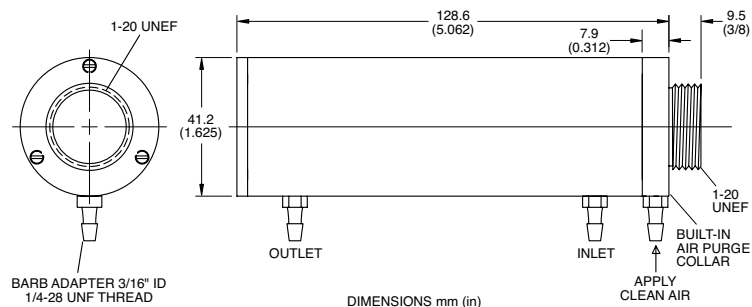

Water/Air Cool Jacket, OS137-WC

Alarm Setting

The unit provides 0-100% alarm setpoint adjustment. Here is an example of an alarm setting:

- An OS137A-3-MA (4/20 mA output), the alarm is to be set at 204°C (400°F) temperature.
- Connect the alarm output (see Alarm Output Wiring Diagram)
- Remove the End Cap to get to the Alarm Switch and the Alarm Adjust (see Location of Emissivity & Alarm Adjust and Alarm Switch)
- Set the Slide Switch on the main board to the Alarm position.
- Measure the analog output, and adjust the Alarm Potentiometer until the output reads 10.4 mA which is 40% (204°C, 400°F) of the temperature range -18 to 538°C, (0 to 1000°F) [$10.4\text{mA} = \frac{40 \times (20-4)}{100} + 4$]
- Set the Alarm Slide Switch back to the Real Time Position.
- If the temperature reading is below the alarm setpoint, the Alarm Output stays low, otherwise it goes high (Alarm Condition).

6

- The Alarm Output can drive an external mechanical relay.

Operating The Laser Sight Accessory

The laser sight accessory screws onto the front of the transmitter sensor head. This accessory is only used for alignment of the transmitter head to the target area. After the alignment process, the accessory has to be removed from the front of the transmitter head before temperature measurement is made.

The laser sight accessory is powered from a small, compact battery pack (included with accessory). Connect the battery pack to the accessory using the cable provided. Aim at the target, and turn on the battery power using the slide switch on the battery pack. Adjust the sensor head position so that the laser beam points to the center of the target area. Turn off the battery pack, and remove the laser sighting and remove the laser sighting accessory from the sensor head.

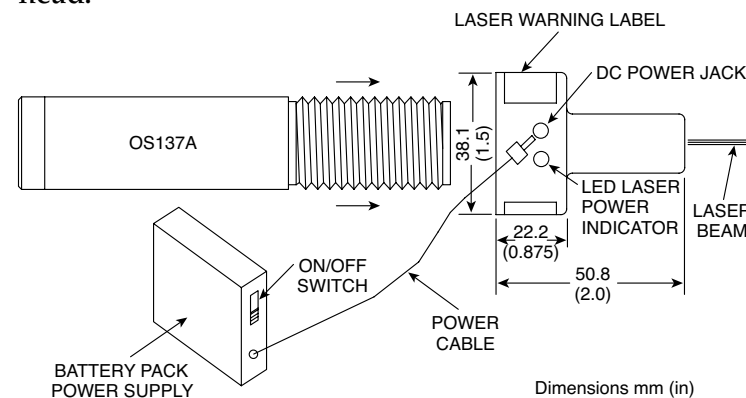

Laser Sighting Accessory, OS137-LS



Laser Warning Label

QUICK START

For complete product manual:
www.omega.com/manuals/manualpdf/M4015.pdf



OS137A SERIES Miniature Non-Contact Infrared Temperature Sensor/Transmitter

OMEGA™

omega.com info@omega.com

Servicing North America:

U.S.A. Headquarters: Omega Engineering, Inc.
Toll-Free: 1-800-826-6342 (USA & Canada only)
Customer Service: 1-800-622-2378 (USA & Canada only)
Engineering Service: 1-800-872-9436 (USA & Canada only)
Tel: (203) 359-1660 Fax: (203) 359-7700
e-mail: info@omega.com

For Other Locations Visit omega.com/worldwide

It is the policy of OMEGA Engineering, Inc. to comply with all worldwide safety and EMC/EMI regulations that apply. OMEGA is constantly pursuing certification of its products to the European New Approach Directives. OMEGA will add the CE mark to every appropriate device upon certification.

The information contained in this document is believed to be correct, but OMEGA accepts no liability for any errors it contains, and reserves the right to alter specifications without notice.

WARNING: These products are not designed for use in, and should not be used for, human applications.

START HERE

Using This Quick Start Manual

Use this Quick Start Manual with your OS137A Series Miniature Infrared Transmitter for quick installation and basic operation. For detailed information, refer to the User's Guide (Manual # M4015).

General Information

The OS137A Series is a precision, miniature infrared transmitter. It measures temperature via non-contact, and provides an analog output proportional to the measured temperature. The OS137A Series is offered in three temperature ranges: 0 to 100°C (32 to 212°F), -18 to 260°C (0 to 500°F) and -18 to 538°C (0 to 1000°F). The analog output is offered as 4 to 20 mA, 0 to 5 Vdc, 0 to 10 Vdc, 10 mV/degree C or F, or K type thermocouple.

The unit provides adjustable emissivity from 0.5 to 1.0, 10 to 1 optical field of view, and field adjustable alarm output.

The super-compact design, 25.4 mm OD x 127 mm length (1.0" OD x 5.0" L) is ideal to measure temperature in confined and hard to reach places. The Stainless Steel housing is NEMA-4 rated. The unit comes standard with a 1.82 m (6') shielded cable.

Electrical Connection

The shielded cable provides the power and output connections. General Wiring Diagram shows the wiring diagram for different analog outputs. Alarm Output Wiring Diagram shows alarm output connections.

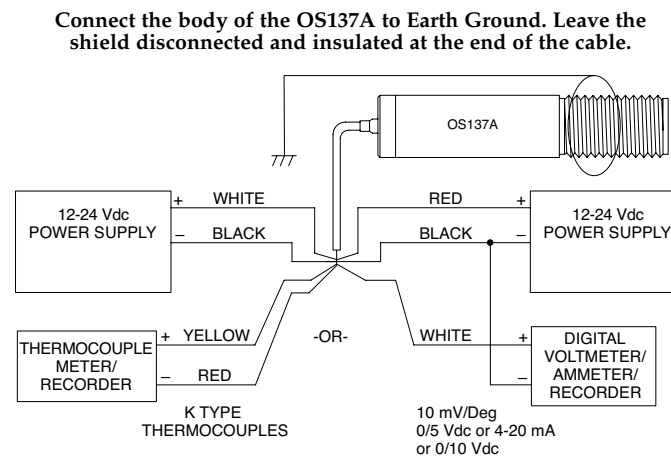

General Wiring Diagram

2

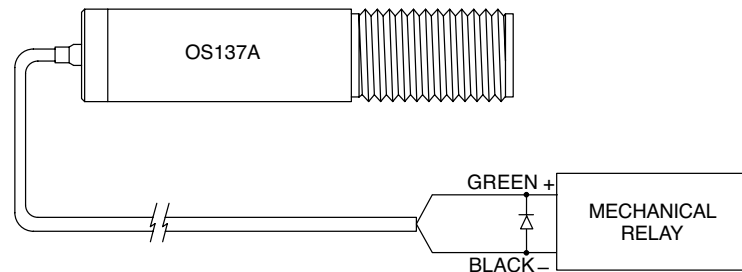

Alarm Output Wiring Diagram

! WARNING!

Connecting the Green alarm lead to ground, or to any load exceeding 100mA, will result in damage to the OS137A and void the warranty. If the alarm output is not being used, it must be left disconnected and insulated.

Operation

Measuring Temperature

Before starting to measure temperature, make sure the following check list is met:

- The power and output connections are made (see General Wiring Diagram)
- The target is larger than the optical field of view of the transmitters (see Optical Field of View)
- Use the Laser Sighting accessory (optional), to align the transmitter to the center of the target area.
- Remove the End Cap to get to the Emissivity Single Turn pot (see Location of Emissivity & Alarm Adjust and Alarm Switch). Set the Emissivity Pot based on the target surface. Then put back the End Cap.
- Make sure the output load is within the product specification

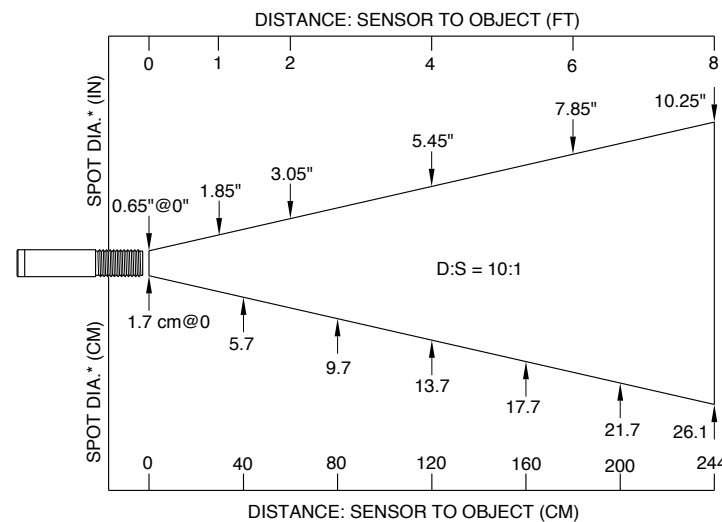

* SPOT DIAMETER MEASURED AT 90% ENERGY

Optical Field Of View

3

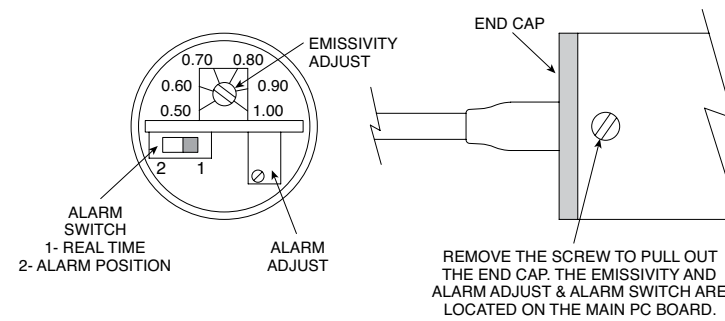

Location of Emissivity and Alarm Adjust and Alarm Switch

Atmospheric Quality

The transmitter can operate in an ambient temperature of 0 to 70°C (32 to 158°F) without any water cool jacket. It can operate from 0 to 200°C (32 to 392°F) with the water cool jacket accessory, OS137-WC. It can operate up to 110°C (230°F) with air cooling.

There is a warm up period of 1 to 2 minutes after power up. After the warm up period, temperature measurement can be made.

When the ambient temperature around the transmitter changes abruptly, the sensor head goes through a thermal shock. It takes a certain amount of time for the sensor head to get stabilized to the new ambient temperature. For example, it takes about 30 minutes for the transmitter to stabilize from the 25°C to 50°C (77°F to 122°F) ambient temperature.

Atmospheric Quality

Environments with smoke, dust, and fumes dirty up the optical lens, and cause erroneous temperature readings. To keep the surface of the optical lens clean, the air purge collar accessory is recommended, OS137-AP.

The following figures show the Air Purge Collar (OS137-AP), Stainless Steel Housing and Water/Air Cool Jacket (OS137-WC), with built-in air purge collar.

4

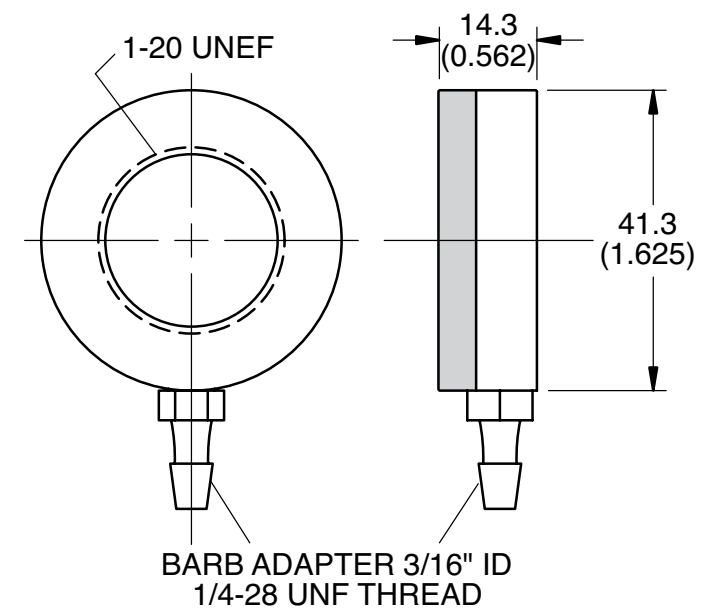

DIMENSIONS mm (in)

Air Purge Collar, OS137-AP

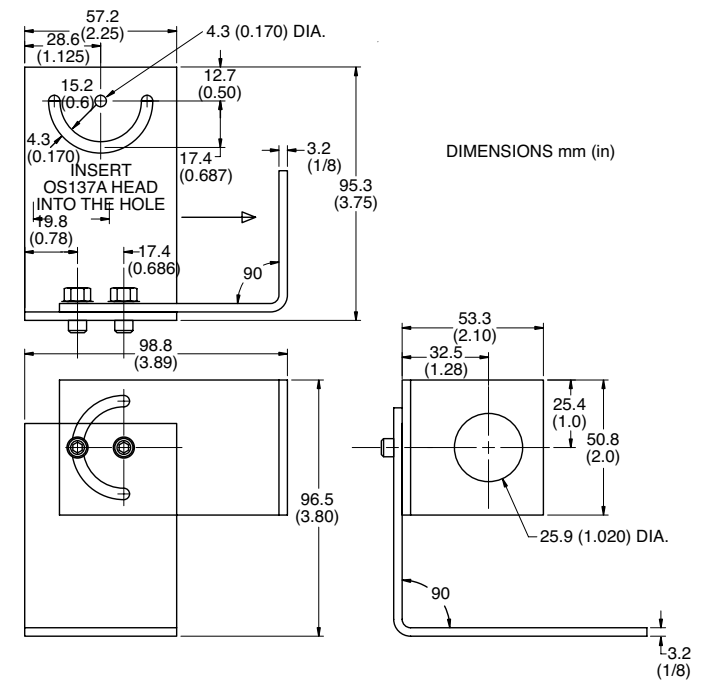

DIMENSIONS mm (in)

Mounting Bracket, OS137-MB