

WARRANTY/DISCLAIMER

OMEGA ENGINEERING, INC. warrants this unit to be free of defects in materials and workmanship for a period of **13 months** from date of purchase. OMEGA's WARRANTY adds an additional one (1) month grace period to the normal **one (1) year product warranty** to cover handling and shipping time. This ensures that OMEGA's customers receive maximum coverage on each product.

If the unit malfunctions, it must be returned to the factory for evaluation. OMEGA's Customer Service Department will issue an Authorized Return (AR) number immediately upon phone or written request. Upon examination by OMEGA, if the unit is found to be defective, it will be repaired or replaced at no charge. OMEGA's WARRANTY does not apply to defects resulting from any action of the purchaser, including but not limited to mishandling, improper interfacing, operation outside of design limits, improper repair, or unauthorized modification. This WARRANTY is VOID if the unit shows evidence of having been tampered with or shows evidence of having been damaged as a result of excessive corrosion; or current, heat, moisture or vibration; improper specification; misapplication; misuse or other operating conditions outside of OMEGA's control. Components in which wear is not warranted, include but are not limited to contact points, fuses, and triacs.

OMEGA is pleased to offer suggestions on the use of its various products. However, OMEGA neither assumes responsibility for any omissions or errors nor assumes liability for any damages that result from the use of its products in accordance with information provided by OMEGA, either verbal or written. OMEGA warrants only that the parts manufactured by the company will be as specified and free of defects. OMEGA MAKES NO OTHER WARRANTIES OR REPRESENTATIONS OF ANY KIND WHATSOEVER, EXPRESSED OR IMPLIED, EXCEPT THAT OF TITLE, AND ALL IMPLIED WARRANTIES INCLUDING ANY WARRANTY OF MERCHANTABILITY AND FITNESS FOR A PARTICULAR PURPOSE ARE HEREBY DISCLAIMED. LIMITATION OF LIABILITY: The remedies of purchaser set forth herein are exclusive, and the total liability of OMEGA with respect to this order, whether based on contract, warranty, negligence, indemnification, strict liability or otherwise, shall not exceed the purchase price of the component upon which liability is based. In no event shall OMEGA be liable for consequential, incidental or special damages.

CONDITIONS: Equipment sold by OMEGA is not intended to be used, nor shall it be used: (1) as a "Basic Component" under 10 CFR 21 (NRC), used in or with any nuclear installation or activity; or (2) in medical applications or used on humans. Should any Product(s) be used in or with any nuclear installation or activity, medical application, used on humans, or misused in any way, OMEGA assumes no responsibility as set forth in our basic WARRANTY/DISCLAIMER language, and, additionally, purchaser will indemnify OMEGA and hold OMEGA harmless from any liability or damage whatsoever arising out of the use of the Product(s) in such a manner.

RETURN REQUESTS/INQUIRIES

Direct all warranty and repair requests/inquiries to the OMEGA Customer Service Department. BEFORE RETURNING ANY PRODUCT(S) TO OMEGA, PURCHASER MUST OBTAIN AN AUTHORIZED RETURN (AR) NUMBER FROM OMEGA'S CUSTOMER SERVICE DEPARTMENT (IN ORDER TO AVOID PROCESSING DELAYS). The assigned AR number should then be marked on the outside of the return package and on any correspondence.

FOR **WARRANTY** RETURNS, please have the following information available BEFORE contacting OMEGA:

1. Purchase Order number under which the product was PURCHASED,
2. Model and serial number of the product under warranty, and
3. Repair instructions and/or specific problems relative to the product.

FOR **NON-WARRANTY** REPAIRS, consult OMEGA for current repair charges. Have the following information available BEFORE contacting OMEGA:

1. Purchase Order number to cover the COST of the repair or calibration,
2. Model and serial number of the product, and
3. Repair instructions and/or specific problems relative to the product.

OMEGA's policy is to make running changes, not model changes, whenever an improvement is possible. This affords our customers the latest in technology and engineering.

OMEGA is a trademark of OMEGA ENGINEERING, INC.

© Copyright 2018 OMEGA ENGINEERING, INC. All rights reserved. This document may not be copied, photocopied, reproduced, translated, or reduced to any electronic medium or machine-readable form, in whole or in part, without the prior written consent of OMEGA ENGINEERING, INC.

5

Mode Button Operation

To activate the "MODE" button, place the tip of the magnetic stylus over the "MODE" button and hold for three seconds until the unit enters the "MODE" menu. Then move away the magnetic stylus. Each time the magnetic stylus is again placed near the "MODE" button the meter will step through each parameter.

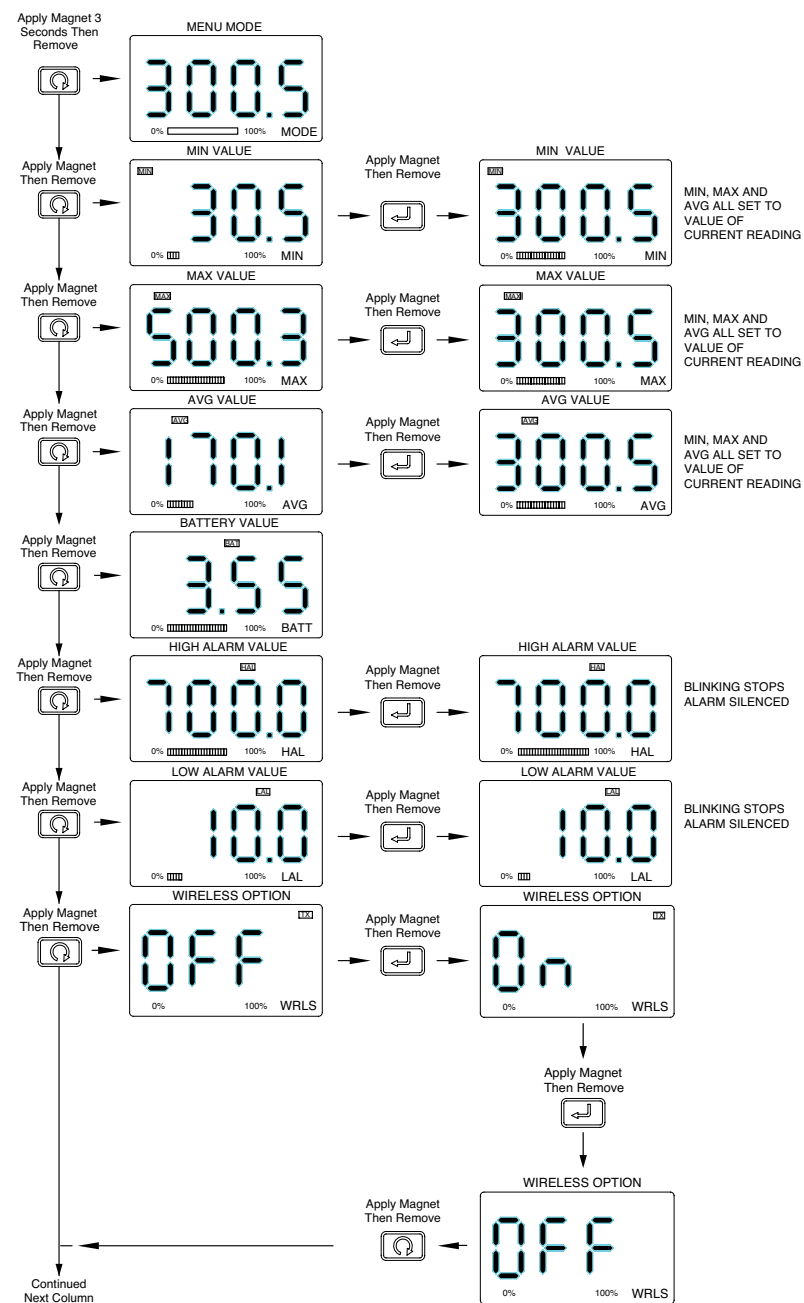

Menu Button Operation

6

Set Button Operation

The "SET" button has two primary functions. Independently the button is used to turn the backlighting on. To activate the "SET" button, place the tip of the magnetic stylus over the "SET" button and hold for three seconds until the backlighting turns on. The backlighting will remain on for the amount of time you selected during the setup and configuration process. Note: if you selected "Always Off" when setting the meter up, then the "SET" button will not turn the backlighting on from the front keypad.

When in the "MODE" menu, the "SET" button is used to turn the wireless transmitter "On" or "Off" and also to select the unit of measurement.

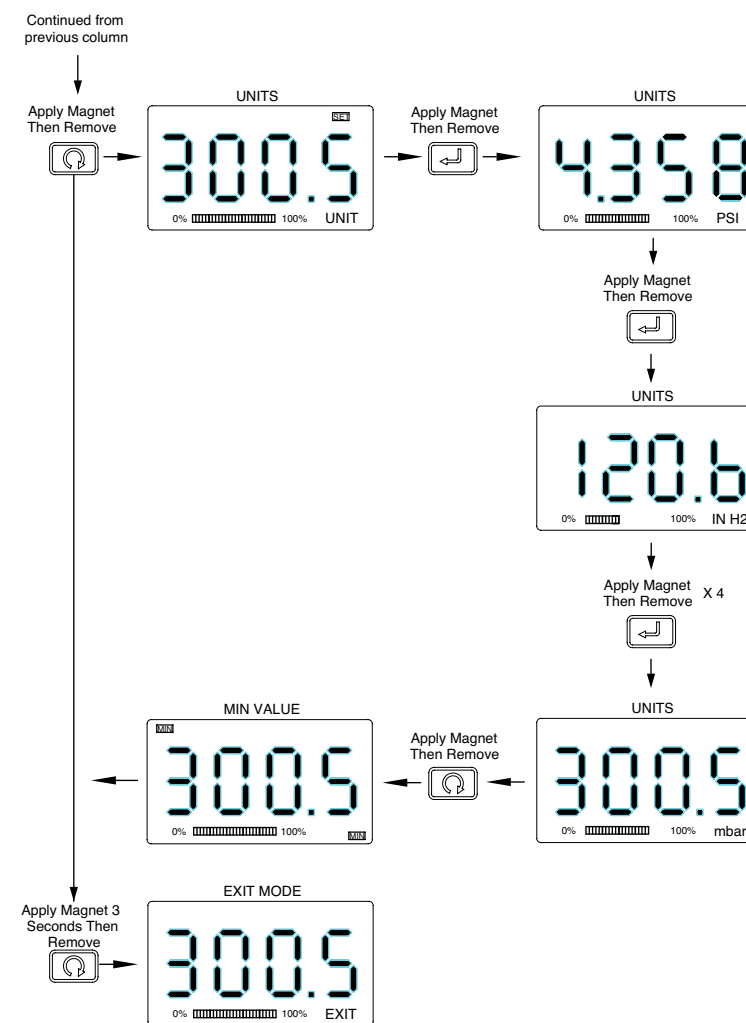

Menu Button Operation Cont'd

QUICK START

For complete product manual:
www.omega.com/manuals/manualpdf/M4978A.pdf



DPG409 SERIES High Accuracy Digital Pressure Gauge

OMEGA

omega.com info@omega.com

Servicing North America:

U.S.A. Headquarters: Omega Engineering, Inc.
 Toll-Free: 1-800-826-6342 (USA & Canada only)
 Customer Service: 1-800-622-2378 (USA & Canada only)
 Engineering Service: 1-800-872-9436 (USA & Canada only)
 Tel: (203) 359-1660 Fax: (203) 359-7700
 e-mail: info@omega.com

For Other Locations Visit omega.com/worldwide

The information contained in this document is believed to be correct, but OMEGA accepts no liability for any errors it contains, and reserves the right to alter specifications without notice.

The information contained in this document is believed to be correct, but OMEGA accepts no liability for any errors it contains, and reserves the right to alter specifications without notice.

START HERE

Using This Quick Start Manual

Use this Quick Start Manual with your DPG409 Series high accuracy digital pressure gauge for quick installation and basic operation. For detailed information, refer to the User's Guide available at <https://www.omega.com/manuals/manualpdf/M4978A.pdf>.

General Description

Omega's DPG409 Series Digital Pressure Gauges incorporate rugged, 316 Stainless Steel enclosures that are designed specifically for wash-down, sanitary and marine applications. The large backlit LCD display features 1" high digits that make reading at distances up to 35 feet easy. Models are available with integral standard or sanitary pressure sensors that incorporate highly stable silicon wafer technology which is micro-machined to precision tolerances and then has strain gauges molecularly embedded.

The DPG409 is NEMA 4X rate (water tight, dust tight, corrosion – resistance - indoor & outdoor use). The pressure gauge can be installed in locations where it will be intermittently exposed to spraying water, rain or high humidity. The meter should never be used under water.

Software Installation

Download the Configuration Wizard software from <ftp://ftp.omega.com/public/DASGroup/products/dpg409/>. To install run the setup.exe application. The installer will guide you through the steps required to install the DG Configuration Wizard on your computer.

Lid/Cover Removal

To switch on your unit and access the USB programming connector on your meter, the enclosure lid/cover must be removed. Four screws must be removed. Be careful to not lose or discard these screws. These screws play a vital part in providing the water tight seal on your unit.

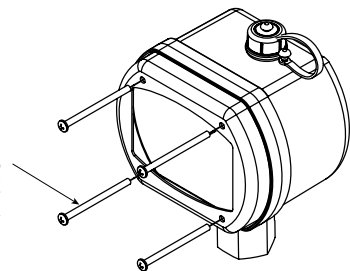

Lid/Cover Removal

2

CAUTION:

Failure to install these screws correctly may results in damage to your unit when the meter is exposed to wet conditions. When reinstalling enclosure screws they must be tightened to 9 in-lb +/- 10%.

Switching On Your DPG409 Meter

Before you connect your USB cable to the USB programming connector on the DPG409, you will need to switch on the unit.

Setting Up Your Meter

Connect the USB Programming cable included with your unit to your PC and your meter.

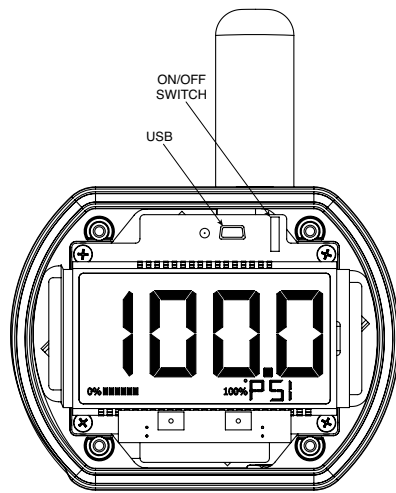

USB Connector Location

Now that you have connected your USB cable to your PC and to your meter, you can now configure your meter before placing the unit into operation. You will be using the configuration software utility that you installed onto your PC. If you have not installed the configuration software utility you should do so now.

Configuring your Meter

The Omega Digital Gauge Configuration Wizard will open once you have launched the DG Configuration Wizard software. Follow the step-by-step instructions given to you by the Configuration Wizard. Step 5 - Choose Options: Select the type of analog output your application requires. You can leave the default setting if you will not be using the analog output feature.

NOTE:

You must set the wire jumpers located on the back of your meter to match the analog output type you selected here in the setup process.

3

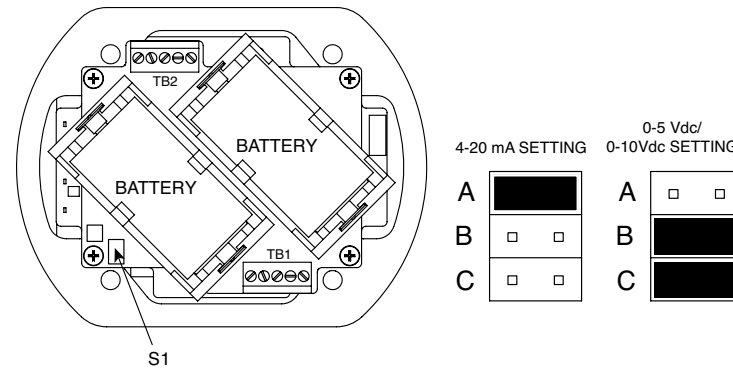

Analog Output Options

Installation

Mounting

For mounting dimensions refer to the User's Guide, Page 4-1, Figure 4-1.

Ambient Temperature

Your meter should only be installed in locations that maintain an ambient temperature between -18 to 66°C (0 to 150°F).

Battery Installation/Replacement

To install or replace the battery in your DPG409 pressure gauge you must first remove the four screws located on the Lid of the enclosure. This will allow you to remove the meter assembly and access the battery holders.

NOTE:

Model DPG409 requires only one battery for normal operation (Battery 1). A second battery (Battery 2) can be added to extend operation when on battery power. It is also recommended that the additional battery (Battery 2) be installed for models that include the optional wireless transmitter.

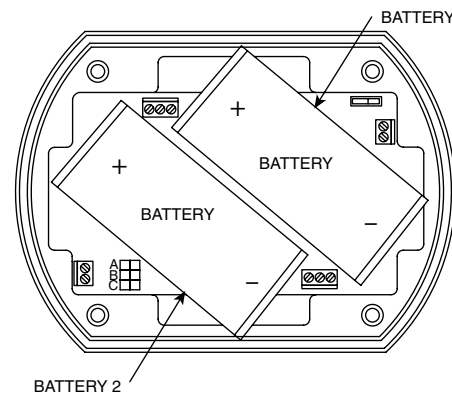

Battery Placement

4

Wiring (Power, Analog Output)

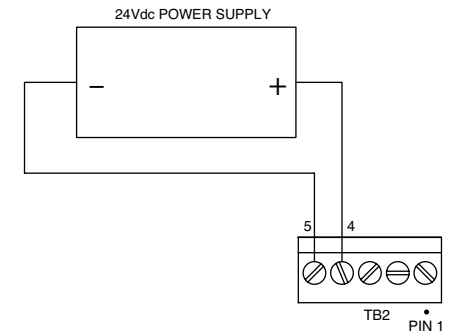

Wiring - Power Supply

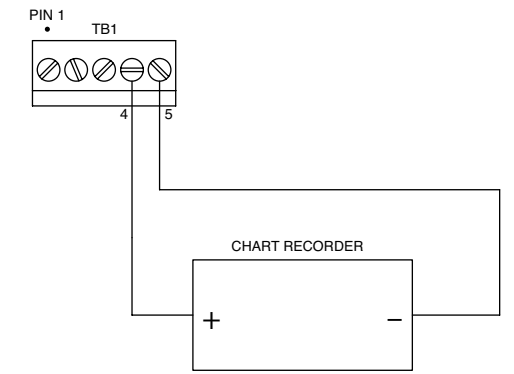

Wiring - Analog Output

For alarm wiring information refer to the User's Guide, Page 4-4, Figure 4-5.

Keypad Operation

Magnetic Stylus

A magnetic stylus is attached to your meter. This stylus is used to activate the front buttons on the display. If you do not need to view the "MIN", "MAX" or "AVERAGE" readings during normal operation, or have a need to turn the backlight on during normal operation you can remove and store this stylus. You will need to select "Disable Keypad" during the setup and configuration process.

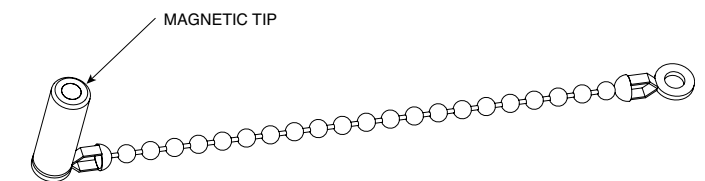

Magnetic Stylus

The "MODE" and "SET" buttons located on the front of the display of your meter are activated by waving or tapping the magnetic stylus included with your unit above or onto the keypad button symbol on the front meter label.