

FLOW CHART

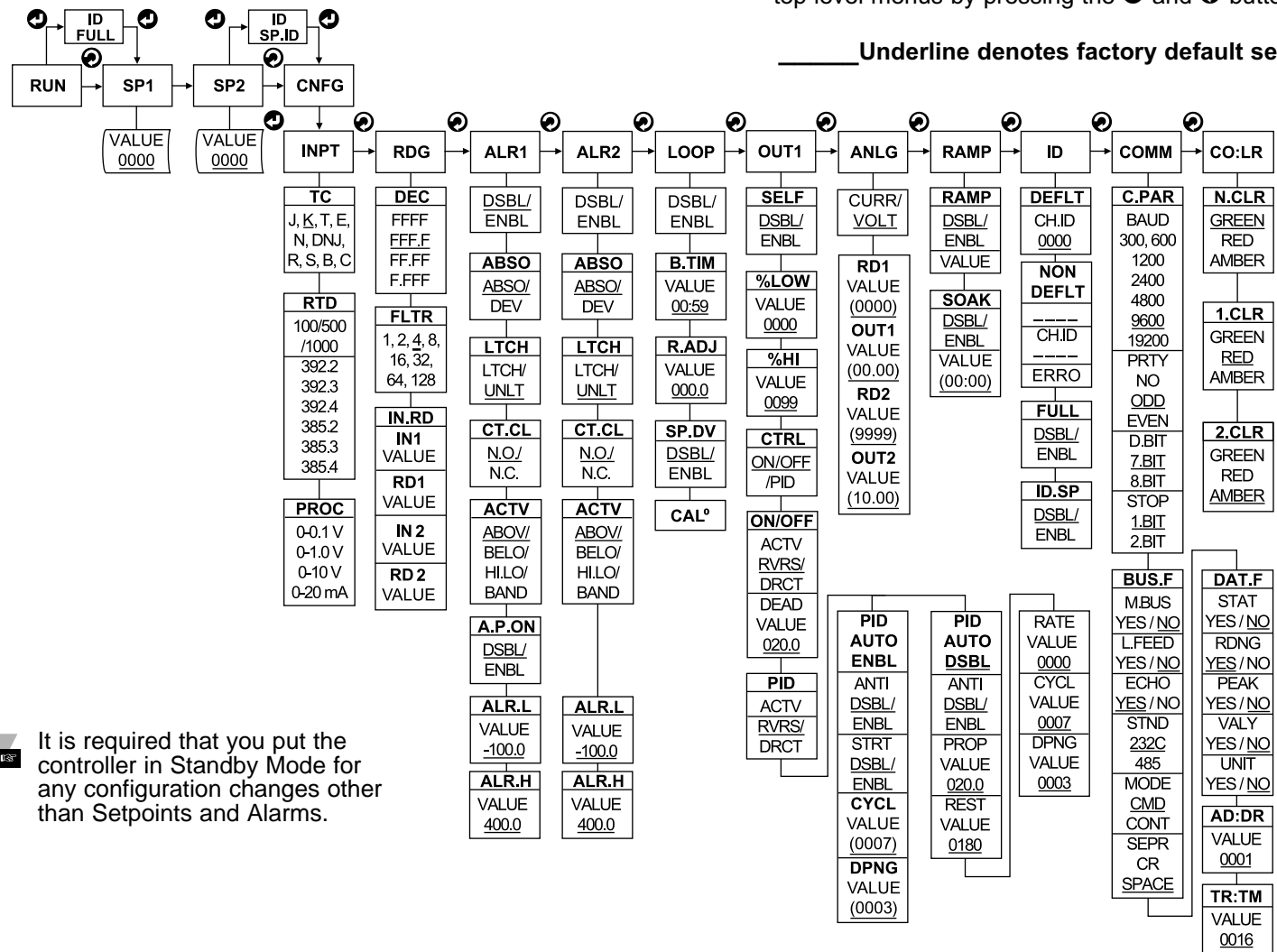

Below is a flowchart showing how to navigate through all top level menus by pressing the **↶** and **↷** buttons.

_____ Underline denotes factory default setup

Note It is required that you put the controller in Standby Mode for any configuration changes other than Setpoints and Alarms.

INPUT MENU SETUP (operation example)

Below is a flowchart showing how to navigate through the submenus of Input menu item by pressing the front buttons.

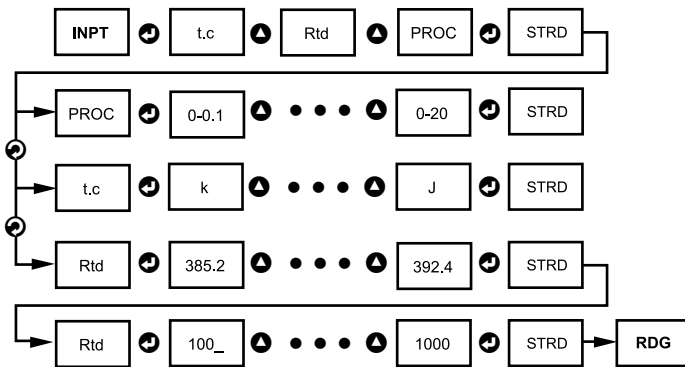

DISPLAY COLOR SETUP (examples)

Example 1:
Output 1 & Output 2: SSR
Alarm setup: Absolute, Above, Alarm 2 HI Value "ALR.H" =200, Alarm 1 HI Value "ALR.H"=400
Color Display setup: Normal Color "N.CLR"=Green, Alarm 1 Color "1.CLR"=Amber, Alarm 2 Color "2.CLR"=Red

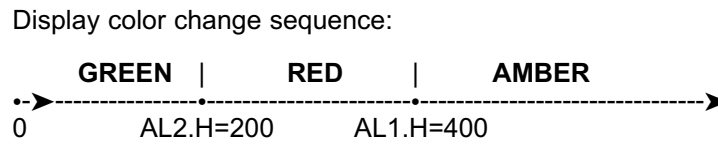

Example 2:
Output 1: Relay, Set Point 1 = 200,
Output 2: Relay, Set Point 2 = 200
Alarm 1 setup: Deviation, Band, "ALR.H" = 20
Alarm 2 setup: Deviation, Hi/Low, "ALR.H = 10", "ALR.L = 5"
Color Display setup: "N.CLR"=Green, "1.CLR"=Amber, "2.CLR"=Red

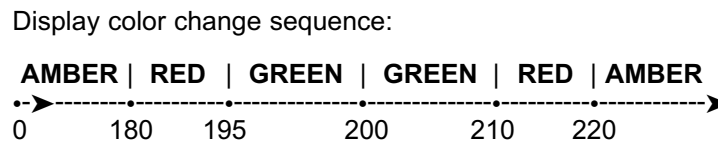

SPECIFICATION

Accuracy:
 +0.5°C temp;
 0.03% rdg. process typical

Resolution:
 1°/0.1°; 10 µV process

Temperature Stability:
 0.04°C/°C RTD;
 0.05°C/°C TC @ 25°C (77°F);
 50 ppm/°C process

iDRP Remote Programmer/Display Option:
 4-digit, 9-segment LED 21 mm (0.83"),
 48H x 96W x 39D (1.89 x 3.78 x 1.55"),
 159g (0.35 lbs). Red, green, and amber programmable colors for process variable, set point and temperature units.

Input Types:
 Thermocouple, RTD, Analog Voltage and Current

TC (ITS 90):
 J, K, T, E, R, S, B, C, N, L

RTD (ITS 68):
 100/500/1000 ohm Pt sensor
 2-, 3-, or 4-wire; 0.00385 or 0.00392 curve

Input Impedance:
 10 MΩ for 100 mV
 1 MΩ for 1 or 10 Vdc

Voltage:
 0 to 100mV (±50mV), 0 to 1V, 0 to 10Vdc

Current:
 0 to 20 mA (5 Ω load)

Output 1: (Control/Alarm Output)
 Relay 250 Vac @ 3 A Resistive Load, SSR, or Pulse,

Output 2: (Alarm Output)
 Relay 250 Vac @ 3 A Resistive Load, SSR, or Pulse

Output 3: (Retransmission)
 Isolated Analog Voltage and Current
 Current: 10 V max @ 20 mA output
 Voltage: 20 mA max for 0 - 10 V output

Options: Communication
 RS-232 / RS-485 or
Excitation: 24 Vdc @ 25 mA
Exc. not available for Low Power Option

Line Voltage/Power:
 90 - 240 Vac ±10%, 50 - 400 Hz*,
 or 110 - 375 Vdc, 5 W
 * No CE compliance above 60 Hz

Low Voltage Power Option:
 20 - 36 Vdc, 4 W**
 ** Units can be powered safely with 24 Vac but No Certification for CE/UL are claimed.

Dimensions:
 92.5H x 125.2D x 32.1mm W
 (3.64 x 4.93 x 1.27")

Weight: 204g (0.45 lbs)

Approvals:
 UL, C-UL, CE per EN61010-1:2001

WARNING: These products are not designed for use in, and should not be used for, patient-connected applications.

This device is marked with the international caution symbol. It is important to read the Setup Guide before installing or commissioning this device, as the guide contains important information relating to safety and EMC.

It is the policy of OMEGA to comply with all worldwide safety and EMC/EMI regulations that apply. OMEGA is constantly pursuing certification of its products to the European New Approach Directives. OMEGA will add the CE mark to every appropriate device upon certification.

The information contained in this document is believed to be correct, but OMEGA Engineering, Inc. accepts no liability for any errors it contains, and reserves the right to alter specifications without notice.

TRADEMARK NOTICE:

Ω, omega.com, OMEGA, and Ω are Trademarks of OMEGA ENGINEERING, INC.

WARRANTY/DISCLAIMER

OMEGA ENGINEERING, INC. warrants this unit to be free of defects in materials and workmanship for a period of **one (1) year** from the date of purchase. In addition to OMEGA's standard warranty period, OMEGA Engineering will extend the warranty period for **four (4) additional years** if the warranty card enclosed with each instrument is returned to OMEGA.

If the unit malfunctions, it must be returned to the factory for evaluation. OMEGA's Customer Service Department will issue an Authorized Return (AR) number immediately upon phone or written request. Upon examination by OMEGA, if the unit is found to be defective, it will be repaired or replaced at no charge. OMEGA's WARRANTY does not apply to defects resulting from any action of the purchaser, including but not limited to mishandling, improper interfacing, operation outside of design limits, improper repair, or unauthorized modification. This WARRANTY is VOID if the unit shows evidence of having been tampered with or shows evidence of having been damaged as a result of excessive corrosion, or current, heat, moisture or vibration; improper specification; misapplication; misuse or other operating conditions outside of OMEGA's control. Components which wear are not warranted, including but not limited to contact points, fuses, and triacs.

OMEGA is pleased to offer suggestions on the use of its various products. However, OMEGA neither assumes responsibility for any omissions or errors nor assumes liability for any damages that result from the use of its products in accordance with information provided by OMEGA, either verbal or written. OMEGA warrants only that the parts manufactured by it will be as specified and free of defects. OMEGA MAKES NO OTHER WARRANTIES OR REPRESENTATIONS OF ANY KIND WHATSOEVER, EXPRESS OR IMPLIED, EXCEPT THAT OF TITLE, AND ALL IMPLIED WARRANTIES INCLUDING ANY WARRANTY OF MERCHANTABILITY AND FITNESS FOR A PARTICULAR PURPOSE ARE HEREBY DISCLAIMED. LIMITATION OF LIABILITY: The remedies of purchaser set forth herein are exclusive, and the total liability of OMEGA with respect to this order, whether based on contract, warranty, negligence, indemnification, strict liability or otherwise, shall not exceed the purchase price of the component upon which liability is based. In no event shall OMEGA be liable for consequential, incidental or special damages.

CONDITIONS: Equipment sold by OMEGA is not intended to be used, nor shall it be used: (1) as a "Basic Component" under 10 CFR 21 (NRC), used in or with any nuclear installation or activity; or (2) in medical applications or used on humans. Should any Product(s) be used in or with any nuclear installation or activity, medical application, used on humans, or misused in any way, OMEGA assumes no responsibility as set forth in our basic WARRANTY/DISCLAIMER language, and, additionally, purchaser will indemnify OMEGA and hold OMEGA harmless from any liability or damage whatsoever arising out of the use of the Product(s) in such a manner.

RETURN REQUESTS/INQUIRIES

Direct all warranty and repair requests/inquiries to the OMEGA Customer Service Department, BEFORE RETURNING ANY PRODUCT(S) TO OMEGA. PURCHASER MUST OBTAIN AN AUTHORIZED RETURN (AR) NUMBER FROM OMEGA'S CUSTOMER SERVICE DEPARTMENT (IN ORDER TO AVOID PROCESSING DELAYS). The assigned AR number should then be marked on the outside of the return package and on any correspondence.

The purchaser is responsible for shipping charges, freight, insurance and proper packaging to prevent breakage in transit.

FOR WARRANTY RETURNS, please have the following information available BEFORE contacting OMEGA:

1. Purchase Order number under which the product was PURCHASED,
2. Model and serial number of the product under warranty, and
3. Repair instructions and/or specific problems relative to the product.

FOR NON-WARRANTY REPAIRS, consult OMEGA for current repair charges. Have the following information available BEFORE contacting OMEGA:

1. Purchase Order number to cover the COST of the repair,
2. Model and serial number of product, and
3. Repair instructions and/or specific problems relative to the product.

OMEGA's policy is to make running changes, not model changes, whenever an improvement is possible. This affords our customers the latest in technology and engineering.

OMEGA is a registered trademark of OMEGA ENGINEERING, INC.

© Copyright 2006 OMEGA ENGINEERING, INC. All rights reserved. This document may not be copied, photocopied, reproduced, translated, or reduced to any electronic medium or machine-readable form, in whole or in part, without the prior written consent of OMEGA ENGINEERING, INC.

PATENT AND TRADEMARK NOTICE: This product is covered by one or more of the following patents: U.S. Pat. No. Des. 336,895; 5,274,577; 6,243,021 / CANADA 2052599; 2052600 / ITALY 1249456; 1250938 / GERMANY DE 41 34398 C2 / SPAIN 2039150; 2048066 / UK Patent No. GB2 249 837; GB2 248 954 / FRANCE BREVET NO. 91 12756. The "Meter Bezel Design" is a trademark of Newport Electronics, Inc. USED UNDER LICENSE. Other U.S. and International Patents pending or applied for.

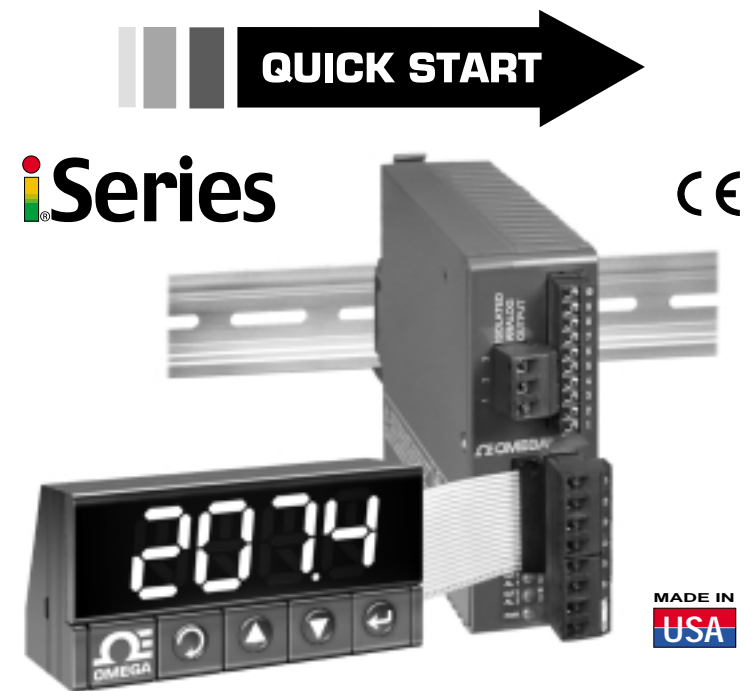

**iDRA Controller
 DIN Rail Temperature/Process
 with Isolated Analog Output**



OMEGAnet® On-Line Service www.omega.com	Internet e-mail info@omega.com
---	--

Servicing North America:

USA: ISO 9001 Certified	One Omega Drive, P.O. Box 4047 Stamford CT 06907-0047 TEL: (203) 359-1660 e-mail: info@omega.com	FAX: (203) 359-7700
Canada:	976 Bergar Laval (Quebec) H7L 5A1 TEL: (514) 856-6928 e-mail: info@omega.ca	FAX: (514) 856-6886

For immediate technical or application assistance:

USA and Canada: Sales Service: 1-800-826-6342 / 1-800-TC-OMEGA®
 Customer Service: 1-800-622-2378 / 1-800-622-BEST®
 Engineering Service: 1-800-872-9436 / 1-800-USA-WHEN®

Mexico and Latin American: TEL: (001)800-TC-OMEGA® FAX: (001) 203-359-7807
 En Español: (001) 203-359-7803
 e-mail: espanol@omega.com

Servicing Europe:

Czech Republic:	Frystatska 184, 733 01 Karviná TEL: +420 59 6311899 e-mail: info@omegashop.cz	FAX: +420 59 6311114
Germany/Austria:	Daimlerstrasse 26, D-75392 Deckenpfronn, Germany TEL: +49 7056 9398-0 Toll Free in Germany: 0800 639 7678 e-mail: info@omega.de	FAX: +49 7056 9398-29
United Kingdom: ISO 9002 Certified	One Omega Drive River Bend Technology Centre Northbank, Irlam Manchester M44 5BD United Kingdom TEL: +44 161 777 6611 FAX: +44 161 777 6622 Toll Free in England: 0800 488 488 e-mail: sales@omega.co.uk	

START HERE

This Quick Start Reference provides information on setting up your instrument for basic operation. The latest complete Communication and Operational Manual as well as free Software are available at www.omega.com/specs/iseries or on the CD-ROM enclosed with your shipment.

SAFETY CONSIDERATION



This device is marked with the international Caution symbol.

The instrument is protected in accordance with EN 61010-1:2001, electrical safety requirements for electrical equipment for measurement, control and laboratory. Remember that the unit has no power-on switch. Building installation should include a switch or circuit-breaker that must be compliant to IEC 947-1 and 947-3.

SAFETY:

- Do not exceed voltage rating on the label located on the side of the instrument housing.
- Always disconnect power before changing signal and power connections.
- Do not use this instrument on a work bench without its case for safety reasons.
- Do not operate this instrument in flammable or explosive atmospheres.
- Do not expose this instrument to rain or moisture.

EMC:

- Whenever EMC is an issue, always use shielded cables.
- Never run signal and power wires in the same conduit.
- Use signal wire connections with twisted-pair cables.
- Install Ferrite Bead(s) on signal wire close to the instrument if EMC problems persist.

MOUNTING

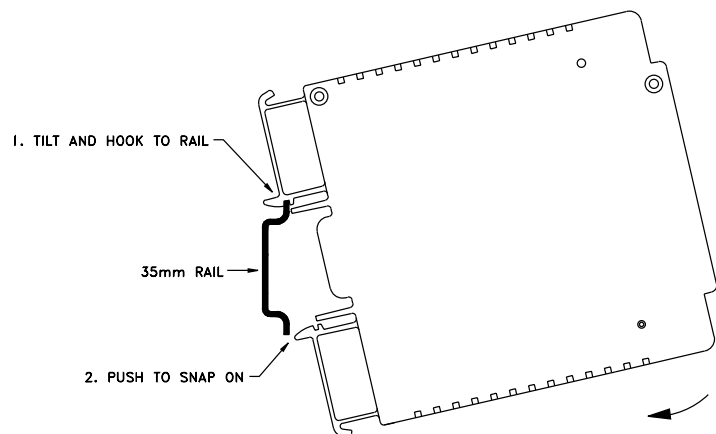

To install unit onto DIN Rail:

- 1) Tilt unit, position mounting slot onto DIN Rail, as shown.
- 2) Push unit towards DIN Rail and it will snap into place.

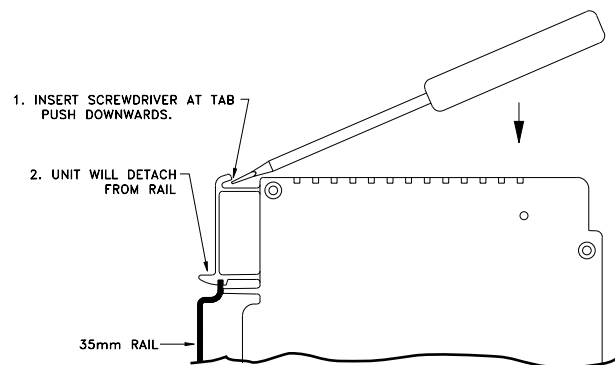

To remove unit from DIN Rail:

- 1) Insert flat screw-driver into tab and push downwards.
- 2) Unit will detach from DIN Rail.

DIMENSIONS

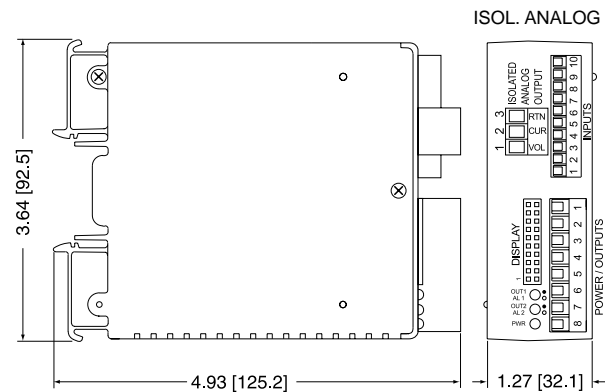

WIRING

Wire the instrument according to the figure shown below.



Warning: Do not connect ac power to your device until you have completed all input and output connections. This device must only be installed by a specially trained electrician with corresponding qualifications. Failure to follow all instructions and warnings may result in injury!

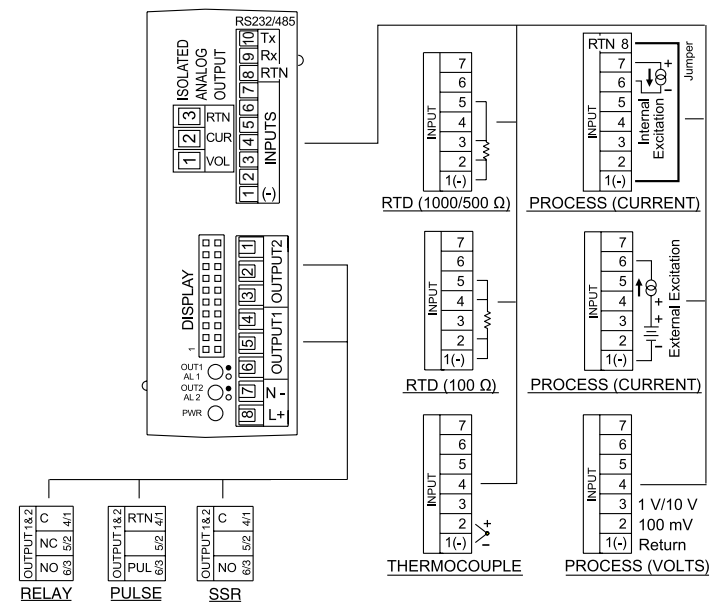

Connect the main power connections as shown in the figure below.

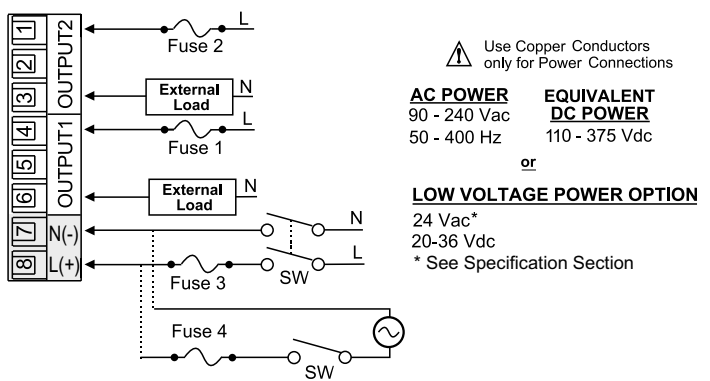

FUSE	Connector	Output Type	For 115Vac	For 230Vac	DC
FUSE 1	Output 1	Relay	3 A(T)	3 A(T)	-
FUSE 2	Output 2	Relay	3 A(T)	3 A(T)	-
FUSE 3	Power	N/A	100 mA(T)	63 mA(T)	63 mA(T)
FUSE 4	Power	N/A	N/A	N/A	400 mA(T)

CONFIGURATION

Note 1-5*

The following steps for configuring your device are explained by using the optional Remote Programmer Display (iDRP), you may also configure your device through the Communication option (-C24).

Button Functions in Configuration Mode

MENU	<ul style="list-style-type: none"> • To enter the Menu, the user must first press MENU button. • Use this button to advance/navigate to the next menu item. The user can navigate through all the top level menus by pressing MENU. • While a parameter is being modified, press this button to escape without saving the parameter.
(UP)	<ul style="list-style-type: none"> • Press the up (UP) button to scroll through "flashing" selections. When a numerical value is displayed press this key to increase value of a parameter that is currently being modified. • Holding the (UP) button down for approximately 3 seconds will speed up the rate at which the set point value is incremented. • In the Run Mode pressing (UP) causes the display to flash the PEAK value – press again to return to the Run Mode.
(DOWN)	<ul style="list-style-type: none"> • Press the down (DOWN) button to go back to a previous Top Level Menu item. • Press this button twice to reset the controller to the Run Mode. • When a numerical value is flashing (except set point value) press this button to scroll digits from left to right allowing the user to select the desired digit to modify. • When a set point value is displayed press this button to decrease value of a set point that is currently being modified. Holding the (DOWN) button down for approximately 3 seconds will speed up the rate at which the setpoint value is decremented. • In the Run Mode pressing (DOWN) causes the display to flash the Valley value - press again to return to the Run Mode.
ENTER	<ul style="list-style-type: none"> • Press this button to access the submenus from a Top Level Menu item. • Press this button to store a submenu selection or after entering a value — the display will flash a StRd message to confirm your selection. • Press this button to reset flashing PEAK value. • In the Run Mode, press ENTER twice to enable Standby Mode with flashing StbM - press again to return to the Run Mode.

Note 1-5*

Reset: Except for Alarms, modifying any settings of the menu configuration will reset the controller prior to resuming Run Mode.

DISPLAY ABBREVIATIONS

SP1	Set Point 1 Value	SP2	Set Point 2 Value
CNFG	Configuration Menu		
INPt	Input Type Menu	t.c	Thermocouple Input
k. . . J	Thermocouple Type	Rtd	RTD Input
385.2	RTD Curve and Connection Type (2, 3, 4-Wire)	100 _	100 _/500 _/1000 _ RTD Sensor
392.4		1000	
PROC	Process Input		
0 - 0.1	100 mV Input Voltage	0 - 1.0	1 V Input Voltage
0 - 20	20 mA Input Current	0 - 10	10 V Input Voltage
RdG	Reading Configuration	dEC	Decimal Point
F.FFF	Decimal Point Position	FLtR	Filter Constant
..FFFF			
0001..	Filter Constant Value	IN.Rd	Input/Reading Scale and Offset Menu
..0128			
IN 1	Input 1	IN 2	Input 2
Rd 1	Reading 1	Rd 2	Reading 2
ALR1	Alarm 1 Menu	AbSo	Absolute Mode
_dEV	Deviation Mode	LtCH	Latched Mode
UNLt	Unlatched Mode	Ct.CL	Contact Closure
N.o.	Normally Open	N.c.	Normally Closed
ActV	Active Type	AboV	Active Above
bELo	Active Below	Hi.Lo	Above High/Below Low
bANd	Above or Below Band	A.P.oN	Alarm Enable/Disable at Power On
ALR.L	Alarm Low Value	ALR.H	Alarm High Value
ALR.2	Alarm 2 Menu		
LOOP	Loop Break Menu	b.tIM	Loop Break Time
R.AdJ	Reading Adjust	SP.dN	Set Point Deviation
Out1	Output 1 Menu	SELF	Manual Control
°LO	Percent Low	°HI	Percent High
CtRL	Control Type	ON.OF	On/Off Control
4 - 20	Amplitude Control	PId	PID Control
ActN	Action Type	RVRS	Reverse Action
dRct	Direct Action	ANt1	Anti Integral
AUto	Auto PID	A.tUN	Auto Tune PID
StRt	Start Auto Tune PID	PRoP	Proportional Band
RESt	Reset Setup	RAtE	Rate Setup
CYCL	Cycle Time	dPNG	Damping Factor
dEAd	Dead Band		
ANLG	Analog Output		
VoLt	Voltage Output	CURR	Current Output
Out.1	Output 1	Rd 1	Reading 1
Out.2	Output 2	Rd 2	Reading 2
RAMP	Ramp Time	SOak	Soak Time
Id	ID Code Menu	CH.Id	Change ID Code
FULL	Full ID	SP.Id	Set Point ID
COMM	Communication Option*	NONE	Communication is Not Installed
COLR	Display Color Selection	N.CLR	Normal Color Display
1.CLR	Alarm 1 Color Display	2.CLR	Alarm 2 Color Display
REd	Display Color is Red	AMbR	Display Color is Amber
GRN	Display Color is Green		
ENbL	Enable	dSbL	Disable
ERRo	Error	+ OL	Input (+) Overload
+OPN	Input (+) Open		

* For abbreviations of Communication Option see Communication Manual.