

**Step 11. Enter to the Thermocouple Type Input Submenu**  
Press **⏏** to display flashing, previously selected Thermocouple type.

**Step 12. Scroll through available selection of TC types**  
Press **⏏** to sequence thru flashing Thermocouple types, (select k -for type "K" CHROMEGA®/ALOMEGA®)  
J K T E N DIN J R S B C - TC types  
J k t E N dN J R S b C - Display

**Step 13. Store TC type**  
After you have selected the Thermocouple type press **⏏** to store your selection, the instrument automatically advances to the next menu item.

**Step 14. Enter to Reading Configuration Menu**  
The display shows **RdD** Reading Configuration, which is the top menu for 4 submenus: Decimal Point, Degree Units, Filter Constant and Input/Reading Submenus.

**Step 15. Enter to Decimal Point Submenu**  
Press **⏏** to show **DEC** Decimal Point.

**Step 16. Display the Decimal Point position**  
Press **⏏** again to display the flashing Decimal Point position.

**Step 17. Select the Decimal Point position**  
Press **⏏** to select **FFFF** Decimal Point position.

**Step 18. Store selected Decimal Point position**  
By pressing **⏏** momentarily the Decimal Point position will be stored and the instrument will go to the next menu item.

**Step 19. Enter to Temperature Unit Submenu**  
Display shows **TEMP** Temperature Unit.

**Step 20. Display available Temperature Units**  
Press **⏏** to display the flashing Degree **F** or **C**.

**Step 21. Scroll through Temperature Units selection**  
Press **⏏** to select **F** Degree.

**Step 22. Store the Temperature Unit**  
Press **⏏** to display momentarily that the Degree Unit has been stored and the instrument will go automatically to the next menu item.

**Step 23. Enter the Filter Constant Submenu**  
Display shows **FLTR** Filter Constant Submenu.

**Step 24. Display the Filter Constant Value Submenu**  
Press **⏏** to display the flashing, previously selected Filter Constant.

**Step 25. Scroll through available Filter Constants**  
Press **⏏** to sequence thru Filter Constants **0001**, **0002**, **0004**, **0008**, **0016**, **0032**, **0064** and **0128**.

**Step 26. Store the Filter Constant**  
Press **⏏** momentarily to store **0004** Filter Constant and the instrument will automatically go to the next menu item.

**Step 27. Enter Alarm 1 Menu**  
The display will show **ALR1** the top menu for Alarm 1. In the following steps we are going to enable Alarm 1, Deviation, Unlatch, Normally Open, Active Above, Enable at power on and +2°F High Alarm i.e. Process Value > Setpoint 1 Value +2°F will activate Alarm 1.

**Note US\*** If Analog Output Option is installed and enabled, the controller will skip Alarm 1 Menu item to Analog Output.

**Step 28. Enter Alarm 1 Enable/Disable Submenu**  
Press **⏏** to display flashing **ASBL** **ENBL**.

**Step 29. Enable Alarm 1 Submenu**  
If flashing **ENBL** is displayed, press **⏏**, if **ASBL** is displayed, press **⏏** until **ENBL** is displayed, then press **⏏** to store and go to the next menu item.

**Step 30. Select the Deviation Control Type Submenu**  
Press **⏏**. If flashing **DEV** Deviation is displayed press **⏏**, otherwise press **⏏** until flashing **DEV** is shown. Now press **⏏** to store and go to next menu item.

**Step 31. Select the Latched Type Submenu**  
Press **⏏**. If flashing **UNL** Unlatched is displayed press **⏏**, otherwise press **⏏** until **UNL** is displayed. Press **⏏** to store and advance to next menu item.

**Step 32. Select the Normally Open Type of Contact Closure Submenu**  
Press **⏏**. If flashing **NO** Normally Open is displayed, press **⏏**, otherwise press **⏏** until **NO** is displayed. Press **⏏** to store and advance to next menu item.

**Step 33. Select the Above Type of Active Submenu**  
Press **⏏**. If flashing **ABO** Above is displayed, press **⏏**, otherwise press **⏏** until **ABO** is displayed. Press **⏏** to store and advance to next menu item.

**Step 34. Enable Alarm 1 at Power On (A.P.ON)**  
Press **⏏**. If flashing **ENBL** is displayed, press **⏏**, otherwise press **⏏** until **ENBL** is displayed. Press **⏏** to store and advance to next menu item.

**Step 35. Enter Alarm 1 High Submenu**  
Press **⏏** twice to skip **ALR1** Alarm 1 Low value. **ALR1** is for below & **ALRH** for above.

**Step 36. Set the Alarm 1 High value (ALRH)**  
Press **⏏**. Press **⏏** or **⏏** until value to set the display to **002.0**. Press **⏏** to save.

**Step 37. Enter the Alarm 2 Menu**  
The display will show **ALR2** the top menu for Alarm 2. Repeat steps from 28 to 36 to set for Alarm 2 the same conditions as for Alarm 1.

**Step 38. Skip the Loop Break Time Menu (LOOP)**  
Press **⏏** to go to the **OUT1** Output 1 Menu item.

**Step 39. Configuration the Output 1 Menu**

**Note US\*** Set Alarm 1 Disabled (Step 29) to be able to Enable Output 1.

Configure Out 1 as **CTRL / PID**, **ACTN / PARS**, **AUTO / ASBL**, **ANL / ENBL**, **PROP / OOS.0**, **RESE / 0180**, **RATE / 018.0**, **CYCL / 0010** and **PNIG / 0003**. Please refer to the operator's manual if needed. Press **⏏** to save and go to the next menu item.

**Step 40. Configuration of Display Color Selection**  
Press **⏏** until the **COLR** Display Color Selection Menu appears on the Display. Configure **COLR** as **NCLR / GRN** (green), **ICLR / RED** (red), **2CLR / AMBR** (amber). Please refer to the operator's manual if needed.

**Note US\*** For color change on Setpoints refer to Owners Manual Section 2.

**Step 41. Run a Test**  
Press **⏏** until reset the controller and return to **RUN** Mode to display **075.0** (Ambient Temperature). Now you are ready to observe temperature as it rises 10°F higher than displayed. Touch the tip of the Thermocouple to raise the temperature above the Alarm 2 High value **082.0**, and AL2 will turn on, and Display Color will change from Green to Amber. Continue touching the tip to raise the temperature above the Alarm 1 High value **087.0** and Display Color will change from Amber to Red. Annunciator "1" is turning on and off displaying output 1.

## SPECIFICATION

### Accuracy:

±0.5°C temp;  
0.03% rdg. process typical

### Resolution:

1°/0.1°; 10 µV process

### Temperature Stability:

0.04°C/°C RTD;  
0.05°C/°C TC @ 25°C (77°F);  
50 ppm/°C process

### iDRP Remote Programmer/Display Option:

4-digit, 9-segment LED 21 mm (0.83"),  
48H x 96W x 39D (1.89 x 3.78 x 1.55"),  
159g (0.35lbs). Red, green, and amber programmable colors for process variable, setpoint and temperature units

### Input Types:

Thermocouple, RTD, Analog Voltage and Current

### TC: (ITS 90)

J, K, T, E, R, S, B, C, N, L

### RTD: (ITS 68)

100/500/1000 ohm Pt sensor  
2-, 3-, or 4-wire; 0.00385 or 0.00392 curve

### Voltage:

0 to 100 mV, 0 to 1 V, 0 to 10 Vdc

### Current:

0 to 20 mA (4 to 20 mA)

### Output 1:

Relay 250 Vac @ 3 A Resistive Load,  
SSR, Pulse, Analog Voltage and Current

### Output 2:

Relay 250 Vac @ 3 A Resistive Load,  
SSR, Pulse

### Options: Communication

RS-232 / RS-485 or 10BaseT  
or Excitation: 24 Vdc @ 25 mA  
EXC. not available for Low Power Option

### Line Voltage/Power:

90 - 240 Vac ±10%, 50 - 400 Hz\*, or  
110 - 375Vdc, 4W

### Low Voltage Power Option:

12-36 Vdc, 3 W\*\*

### Dimensions:

Standard Unit iDR:  
92.5H x 125.2D x 24.9mm W  
(3.64 x 4.93 x 0.98"); 181 g (0.4 lb)

### Ethernet Unit iDR-EI/C4E1:

92.5H x 125.2D x 39.8mm W  
(3.64 x 4.93 x 1.55"); 204 g (0.45 lb)

### Approvals:

UL, C-UL, CE per EN 61010-1:2001

**WARNING:** These products are not designed for use in, and should not be used for, patient-connected applications.

This device is marked with the international caution symbol. It is important to read the Setup Guide before installing or commissioning this device, as the guide contains important information relating to safety and EMC.

It is the policy of OMEGA to comply with all worldwide safety and EMC/EMI regulations that apply. OMEGA is constantly pursuing certification of its products to the European New Approach Directives. OMEGA will add the CE mark to every appropriate device upon certification.

The information contained in this document is believed to be correct, but OMEGA Engineering, Inc. accepts no liability for any errors it contains, and reserves the right to alter specifications without notice.

### TRADEMARK NOTICE:

Ω, omega.com, Ω OMEGA, and Ω are Trademarks of OMEGA ENGINEERING, INC.

**WARRANTY/DISCLAIMER**

OMEGA ENGINEERING, INC. warrants this unit to be free of defects in materials and workmanship for a period of one (1) year from the date of purchase. In addition to OMEGA's standard warranty period, OMEGA Engineering will extend the warranty period for four (4) additional years if the warranty card enclosed with each instrument is returned to OMEGA.

If the unit malfunctions, it must be returned to the factory for evaluation. OMEGA's Customer Service Department will issue an Authorized Return (AR) number immediately upon phone or written request. Upon examination by OMEGA, if the unit is found to be defective, it will be repaired or replaced at no charge. OMEGA's WARRANTY does not apply to defects resulting from any action of the purchaser, including but not limited to mishandling, improper interfacing, operation outside of design limits, improper repair, or unauthorized modification. This WARRANTY is VOID if the unit shows evidence of having been tampered with or shows evidence of having been damaged as a result of excessive corrosion; or current, heat, moisture or vibration; improper specification; misapplication; misuse or other operating conditions outside of OMEGA's control. Components which wear are not warranted, including but not limited to contact points, fuses, and traces.

OMEGA is pleased to offer suggestions on the use of its various products. However, OMEGA neither assumes responsibility for any omissions or errors nor assumes liability for any damages that result from the use of its products in accordance with information provided by OMEGA, either verbal or written. OMEGA warrants only that the parts manufactured by it will be as specified and free of defects. OMEGA MAKES NO OTHER WARRANTIES OR REPRESENTATIONS OF ANY KIND WHATSOEVER, EXPRESS OR IMPLIED, EXCEPT THAT OF TITLE, AND ALL IMPLIED WARRANTIES INCLUDING ANY WARRANTY OF MERCHANTABILITY AND FITNESS FOR A PARTICULAR PURPOSE ARE HEREBY DISCLAIMED. LIMITATION OF LIABILITY: The remedies of purchaser set forth herein are exclusive, and the total liability of OMEGA with respect to this order, whether based on contract, warranty, negligence, indemnification, strict liability or otherwise, shall not exceed the purchase price of the component upon which liability is based. In no event shall OMEGA be liable for consequential, incidental or special damages.

CONDITIONS: Equipment sold by OMEGA is not intended to be used, nor shall it be used: (1) as a "Basic Component" under 10 CFR 21 (NRC), used in or with any nuclear installation or activity; or (2) in medical applications or used on humans. Should any Product(s) be used in or with any nuclear installation or activity, medical application, used on humans, or misused in any way, OMEGA assumes no responsibility as set forth in our basic WARRANTY/DISCLAIMER language, and, additionally, purchaser will indemnify OMEGA and hold OMEGA harmless from any liability or damage whatsoever arising out of the use of the Product(s) in such a manner.

**RETURN REQUESTS/INQUIRIES**

Direct all warranty and repair requests/inquiries to the OMEGA Customer Service Department. BEFORE RETURNING ANY PRODUCT(S) TO OMEGA, PURCHASER MUST OBTAIN AN AUTHORIZED RETURN (AR) NUMBER FROM OMEGA'S CUSTOMER SERVICE DEPARTMENT (IN ORDER TO AVOID PROCESSING DELAYS). The assigned AR number should then be marked on the outside of the return package and on any correspondence.

The purchaser is responsible for shipping charges, freight, insurance and proper packaging to prevent breakage in transit.

<p>FOR WARRANTY RETURNS, please have the following information available BEFORE contacting OMEGA:</p> <ol style="list-style-type: none"> <li>1. Purchase Order number under which the product was PURCHASED,</li> <li>2. Model and serial number of the product under warranty, and</li> <li>3. Repair instructions and/or specific problems relative to the product.</li> </ol>	<p>FOR NON-WARRANTY REPAIRS, consult OMEGA for current repair charges. Have the following information available BEFORE contacting OMEGA:</p> <ol style="list-style-type: none"> <li>1. Purchase Order number to cover the COST of the repair,</li> <li>2. Model and serial number of product, and</li> <li>3. Repair instructions and/or specific problems relative to the product.</li> </ol>
--	--

OMEGA's policy is to make running changes, not model changes, whenever an improvement is possible. This affords our customers the latest in technology and engineering.

OMEGA is a registered trademark of OMEGA ENGINEERING, INC.

© Copyright 2006 OMEGA ENGINEERING, INC. All rights reserved. This document may not be copied, photocopied, reproduced, translated, or reduced to any electronic medium or machine-readable form, in whole or in part, without the prior written consent of OMEGA ENGINEERING, INC.

PATENT AND TRADEMARK NOTICE: This product is covered by one or more of the following patents: U.S. Pat. No. Des. 336,895; 5,274,577; 6,243,021 / CANADA 2052599; 2052600 / ITALY 1249456; 1250838 / GERMANY DE 41 34398 C2 / SPAIN 2039150; 2048066 / UK Patent No. GB2 249 837; GB2 248 954 / FRANCE BREVET NO. 91 12756. The "Meter Bezel Design" is a trademark of Newport Electronics, Inc. USED UNDER LICENSE. Other U.S. and International Patents pending or applied for.

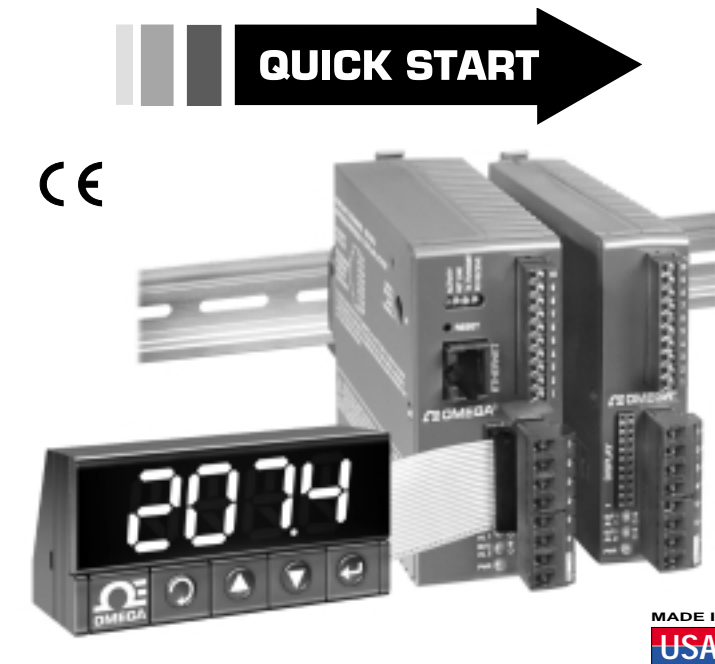

## Series iDR Controller DIN Rail Temperature & Process

**omega.com**  
Ω OMEGA

<b>OMEGAnet® On-Line Service</b> <a href="http://www.omega.com">www.omega.com</a>	<b>Internet e-mail</b> <a href="mailto:info@omega.com">info@omega.com</a>
--	--

### Servicing North America:

**USA:** One Omega Drive, P.O. Box 4047  
Stamford CT 06907-0047  
TEL: (203) 359-1660 FAX: (203) 359-7700  
ISO 9001 Certified e-mail: [info@omega.com](mailto:info@omega.com)

**Canada:** 976 Bergar  
Laval (Quebec) H7L 5A1  
TEL: (514) 856-6928 FAX: (514) 856-6886  
e-mail: [info@omega.ca](mailto:info@omega.ca)

### For immediate technical or application assistance:

**USA and Canada:** Sales Service: 1-800-826-6342 / 1-800-TC-OMEGA®  
Customer Service: 1-800-622-2378 / 1-800-622-BEST®  
Engineering Service: 1-800-872-9436 / 1-800-USA-WHEN®

**Mexico and Latin American:** TEL: (001)800-TC-OMEGA® FAX: (001) 203-359-7807  
En Español: (001) 203-359-7803  
e-mail: [espanol@omega.com](mailto:espanol@omega.com)

### Servicing Europe:

**Czech Republic:** Frystatska 184, 733 01 Karviná  
TEL: +420 59 6311899 FAX: +420 59 6311114  
e-mail: [info@omegashop.cz](mailto:info@omegashop.cz)

**Germany/Austria:** Daimlerstrasse 26, D-75392 Deckenpfronn, Germany  
TEL: +49 7056 9398-0 FAX: +49 7056 9398-29  
Toll Free in Germany: 0800 639 7678  
e-mail: [info@omega.de](mailto:info@omega.de)

**United Kingdom:** One Omega Drive  
ISO 9002 Certified River Bend Technology Centre  
Northbank, Irlam Manchester M44 5BD United Kingdom  
TEL: +44 161 777 6611 FAX: +44 161 777 6622  
Toll Free in England: 0800 488 488  
e-mail: [sales@omega.co.uk](mailto:sales@omega.co.uk)



This Quick Start Reference provides information on setting up your instrument for basic operation. The latest complete Communication and Operational Manual as well as free Software are available at [www.omega.com/specs/series](http://www.omega.com/specs/series) or on the CD-ROM enclosed with your shipment.

### SAFETY CONSIDERATION



This device is marked with the international Caution symbol.

The instrument is protected in accordance with EN 61010-1:2001, electrical safety requirements for electrical equipment for measurement, control and laboratory. Remember that the unit has no power-on switch. Building installation should include a switch or circuit-breaker that must be compliant to IEC 947-1 and 947-3.

### SAFETY:

- Do not exceed voltage rating on the label located on the side of the instrument housing.
- Always disconnect power before changing signal and power connections.
- Do not use this instrument on a work bench without its case for safety reasons.
- Do not operate this instrument in flammable or explosive atmospheres.
- Do not expose this instrument to rain or moisture.

### EMC:

- Whenever EMC is an issue, always use shielded cables.
- Never run signal and power wires in the same conduit.
- Use signal wire connections with twisted-pair cables.
- Install Ferrite Bead(s) on signal wire close to the instrument if EMC problems persist.

### MOUNTING

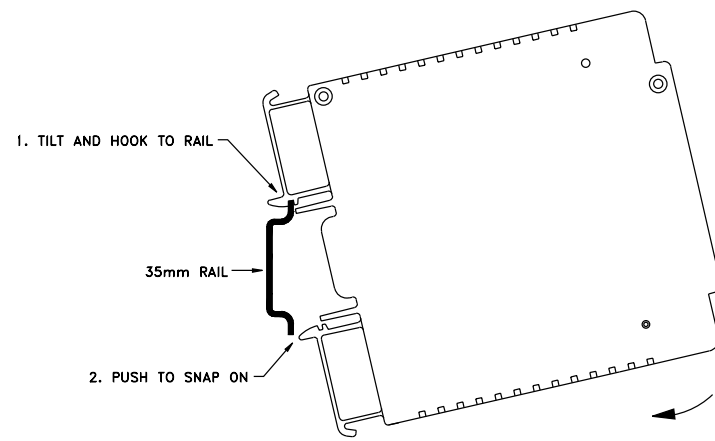

To install unit onto DIN Rail:

- Tilt unit, position mounting slot onto DIN Rail, as shown.
- Push unit towards DIN Rail and it will snap into place.

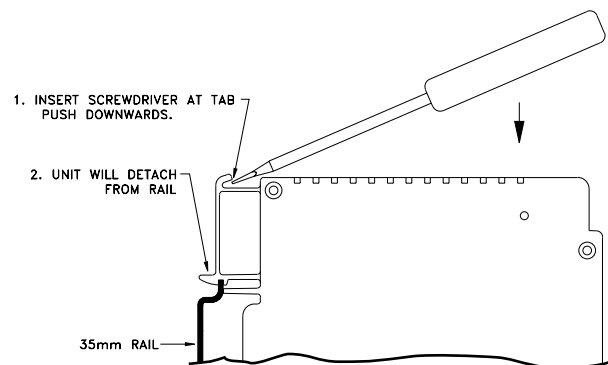

To remove unit from DIN Rail:

- Insert flat screw-driver into tab and push downwards.
- Unit will detach from DIN Rail.

### DIMENSIONS

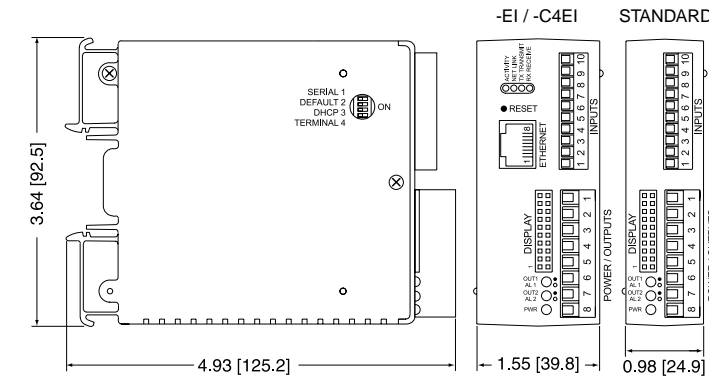

### WIRING

Wire the instrument according to the figure shown below.



**Warning: Do not connect ac power to your device until you have completed all input and output connections. This device must only be installed by a specially trained electrician with corresponding qualifications. Failure to follow all instructions and warnings may result in injury!**

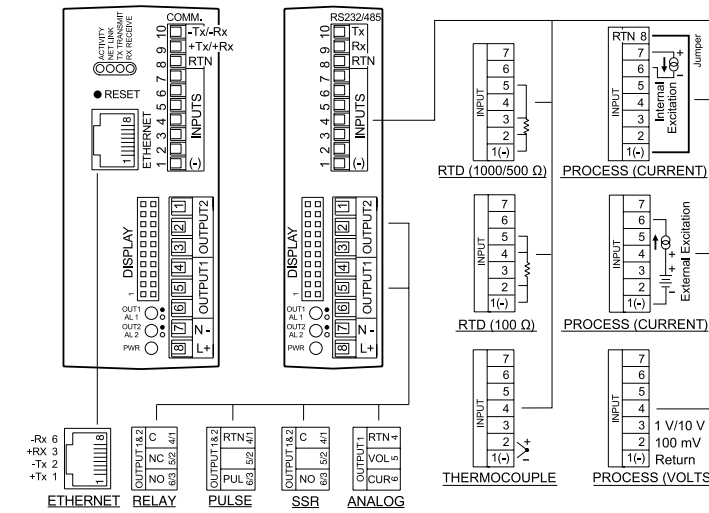

Connect the main power connections as shown in the figure below.

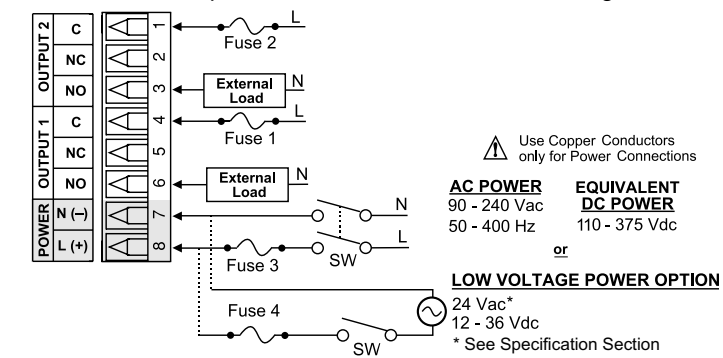

FUSE	Connector	Output Type	For 115Vac	For 230Vac	DC
FUSE 1	Output 1	Relay	3 A(T)	3 A(T)	-
FUSE 2	Output 2	Relay	3 A(T)	3 A(T)	-
FUSE 3	Power	N/A	100 mA(T)	100 mA(T)	100 mA(T)
FUSE 4	Power	N/A	N/A	N/A	400 mA(T)

### CONFIGURATION



The following steps for configuring your device are explained by using the optional Remote Programmer Display (iDRP), you may also configure your device through the Networking or Communication option (-C24, -C4EI or -EI).

### MENU Mode:

Flashing display in MENU Mode means you can make your selection by pressing **▲** button. If the flashing display is not a four digit value, pressing **▼** button will always direct the instrument one step backward of the top menu item. The second push on the **▼** button will reset the instrument except after the setpoint and the alarms, that will go to the RUN Mode without resetting the instrument. The **▶** button will always sequence the instrument thru the menu items.

### The **▶** button has two functions:

- To save a selected flashing display
- To direct the instrument to the next submenu level

### RUN Mode:

- ▶** causes the display to flash the PEAK with the corresponding value. Press again to go back to RUN Mode.
- ▼** causes the display to flash VALLEY with the corresponding value. Press again to go back to RUN Mode.
- ▶** causes flashing PEAK or VALLEY to reset corresponding values. Pressing **▶** twice will cause the display to flash **5E-6V** and put the instrument into standby, which disables all outputs and alarms. Press **▶** one more time to go back to RUN Mode.

### FLOW CHART

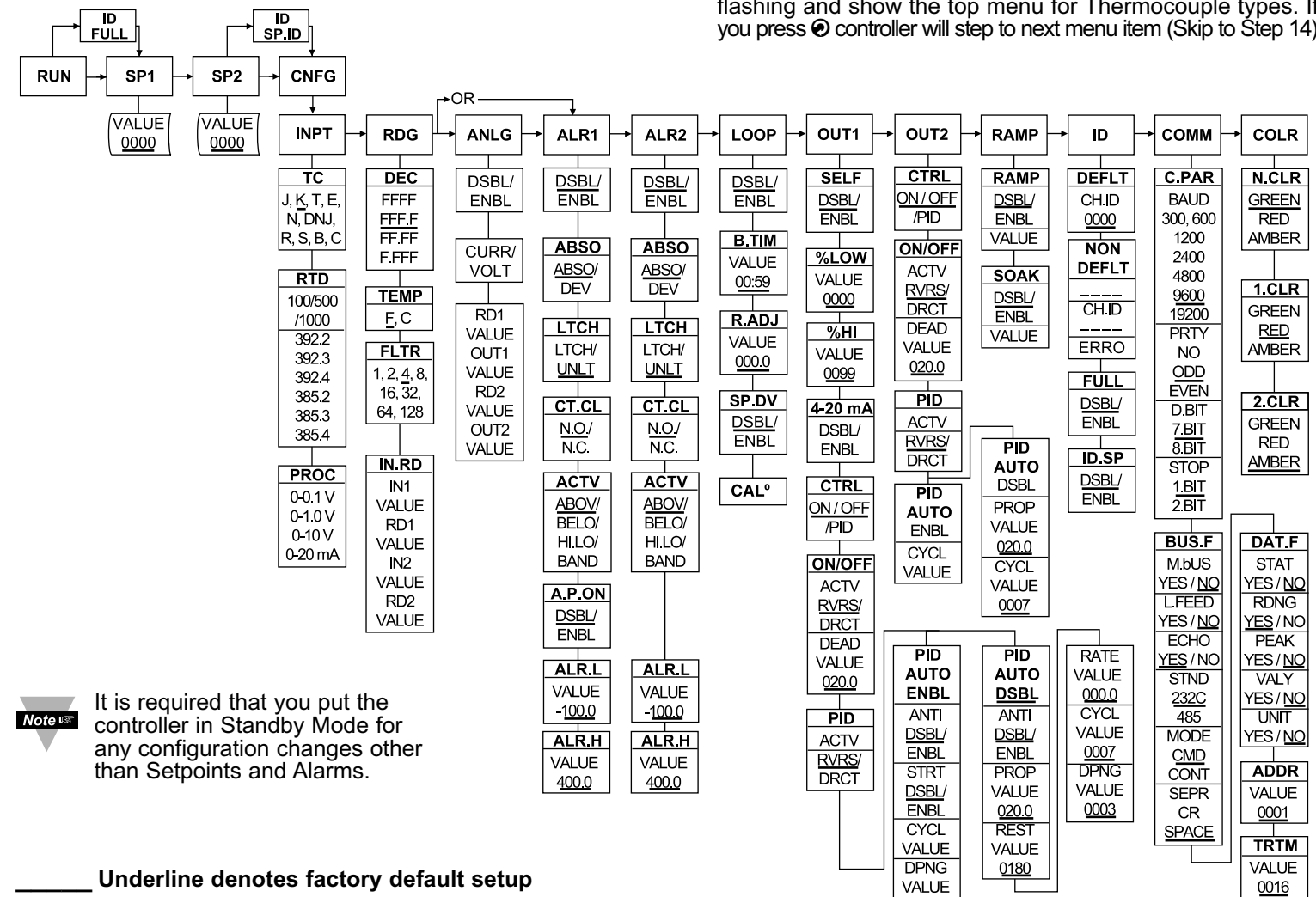

It is required that you put the controller in Standby Mode for any configuration changes other than Setpoints and Alarms.

**Underline denotes factory default setup**

### OPERATION - (For Thermocouple Input)

#### Step 1. Apply Power to the Instrument

When your device is first powered up it will display the ambient temperature (assume 75°F).

#### Step 2. Enter Setpoint 1 Menu

Press **▶** one time from run mode to get to **5P1** Setpoint 1.

#### Step 3. Enter the Setpoint 1 Value Submenu

Press **▶**. Display shows the previous selection of Setpoint 1.

#### Step 4. Change the Setpoint 1 Value

Press **▲** or **▼** until desired value is displayed.

#### Step 5. Store the Setpoint 1 Value

Set the Setpoint 1 to 10 degree higher than Process value (SP1 = 85) and press **▶** to store, display flashes **5E-6V** message and advances to **5P2** Setpoint 2 Menu.

#### Step 6. Store the Setpoint 2 Value

Repeat steps 3 and 4. Set the Setpoint 2 to 5 degree higher than Process value (SP2 = 80) and press **▶** to store, display flashes **5E-6V** message and advances to **CNFG** Configuration Menu.

#### Step 7. Enter the Input Type Menu

Press **▶** to enter **INPT** Input Type Menu.

#### Step 8. Enter to the submenu items of Input Menu

Press **▶** to display Input: Process, RTD or Thermocouple. If flashing **5E-6V** is displayed press **▶** and proceed to Step 11.

#### Step 9. Scroll through available selection of Input Menu

Press **▶** until a flashing **5E-6V** for Thermocouple is displayed.

#### Step 10. Enter to the Thermocouple Input Submenu

Press **▶** to store Thermocouple Input. The display will stop flashing and show the top menu for Thermocouple types. If you press **▶** controller will step to next menu item (Skip to Step 14).