

Installation, Operation and Maintenance Instructions

SERVICE REFERENCE

| | |
|--------------------------------------|--------------|
| DIVISION 4 | SECTION TM |
| SALES REFERENCE (Supersedes PD457-1) | PD457-2 |
| 161-306157-001 | |
| DATE | AUGUST, 2010 |

Type TM- Series Industrial Flanged Immersion Heaters

Note: These instructions relate to all enclosure styles shown within.

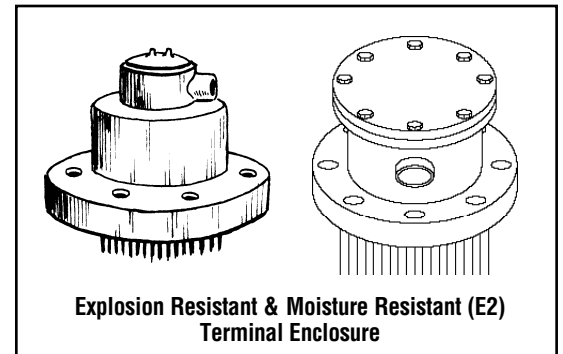
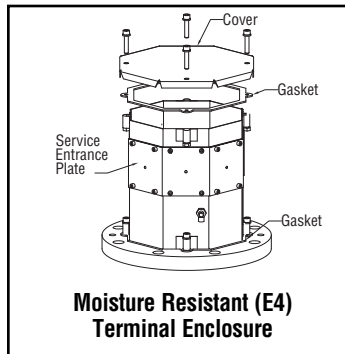
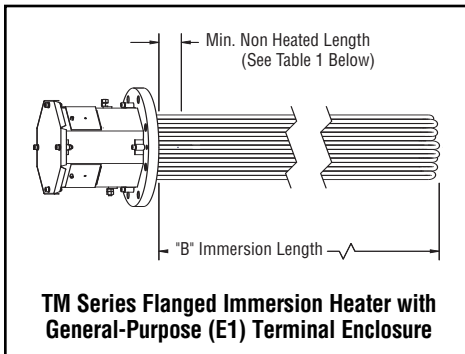

GENERAL

⚠ WARNING

FIRE/EXPLOSION HAZARD. Do not exceed the Pressure-Temperature rating of the flange as listed in ANSI B16.5.

Chromalox TM- Series industrial flanged immersion heaters are designed for a wide variety of heating applications.

1. Heater Construction Characteristics:

- High quality resistance wire held in place by compacted Magnesium Oxide Refractory enclosed in a wide variety of sheath materials.
- Low to high watt densities.
- Standard selection of sheath materials include copper, steel, INCOLOY[®] alloy and stainless steel. This broad selection of sheath materials will operate successfully in many corrosive solutions.

IMPORTANT: It is the responsibility of the purchaser of the heater to make the ultimate choice of sheath material based upon their knowledge of the chemical composition of the corrosive solution, character of the materials entering the solution, and controls which he maintains on the process.

⚠ WARNING

FIRE/EXPLOSION HAZARD. Sheath corrosion can result in a ground fault which, depending upon the solution being heated, can cause an explosion or fire.

- Pipe flange sizes in 3, 5, 6, 8, 10, 12 and 14 inches are standard. Other sizes are also available.
- Units are available with E1 General Purpose, E4 Moisture Resistant and E2 Explosion/Moisture-Resistant terminal enclosures.

⚠ WARNING

FIRE HAZARD. An integral thermostat, if provided, is designed for temperature control service only. Because the thermostat does not fail safe, it should not be used for temperature limiting duty. Wiring to this device is the responsibility of the user.

⚠ WARNING

The system designer is responsible for the safety of this equipment and should install adequate back-up controls and safety devices with their electric heating equipment. Where the consequences of failure could result in personal injury or property damage, back-up controls are essential.

Table 1

| Flange Size | Cold End |
|-------------|----------|
| 3" | 4" |
| 4" | 4" |
| 5" | 4" |
| 6" | 4" |
| 8" | 6" |
| 10" | 6" |
| 12" | 6" |
| 14" | 6" |

Note:

Cold ends listed are standard. However, special cold ends may be used upon request.

INSTALLATION

⚠ WARNING

ELECTRIC SHOCK HAZARD. Disconnect all power before installing or servicing heater. Failure to do so could result in personal injury or property damage. Heater must be installed by a qualified person in accordance with the National Electrical Code, NFPA 70.

1. Before installing, unpack and check your TM series immersion heater for any damage that may have occurred during shipment. Report any claims to your carrier if damage has occurred in shipment. **Do not operate damaged equipment. Consult factory for instructions.**
2. Check to ensure that the line voltage is the same as that stamped on the nameplate. Verify wattage and capacity versus the requirements at installation site.
3. Do not bend the heating elements. If bending is necessary, consult factory.
4. **IMPORTANT:** Mount the heater in the tank so that the liquid level will always be above the effective heated portion of the heater. If the heater is not properly submerged, it may overheat and damage the heating elements (see Figure 1).

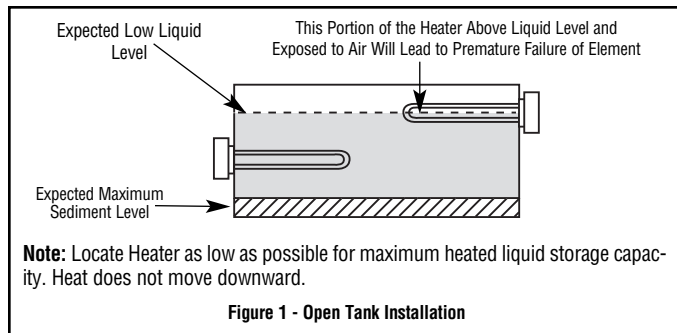

⚠ WARNING

FIRE HAZARD. If the heater is not properly submerged, the heating elements will overheat and could result in a fire or damaged equipment.

5. Where work will pass over or near equipment, additional protection such as a metal guard may be needed.
6. Heater must not be operated in sludge.
7. The gasket surface must be clean and dry before the heater is seated (see Figure 2).
8. Closed Tank Installation
Note: When heating in closed vessels, controls and back-up controls must be used to prevent buildup of temperature and/or pressure.

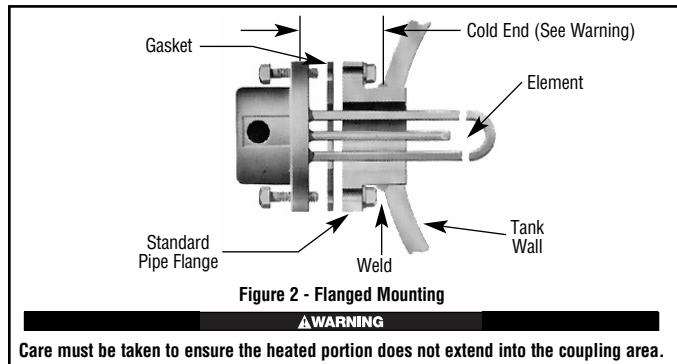

A. Horizontal Position (Figure 3)

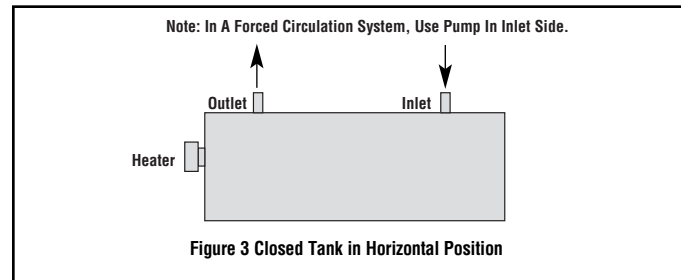

- A1. Place heater at an elevation so that natural circulation can take place.
- A2. Position outlet and inlet in a vertical plane, facing upward to prevent air pockets. Be sure all trapped air is removed from the closed tank. Bleed the air out of the liquid piping system and heater enclosure prior to operation.
- A3. **IMPORTANT:** Heater should never be located at the highest point of the water system. Provide expansion tank if necessary.
- A4. Heaters shall be supported if the immersion length is greater than 36".

B. Vertical Position (Figure 4)

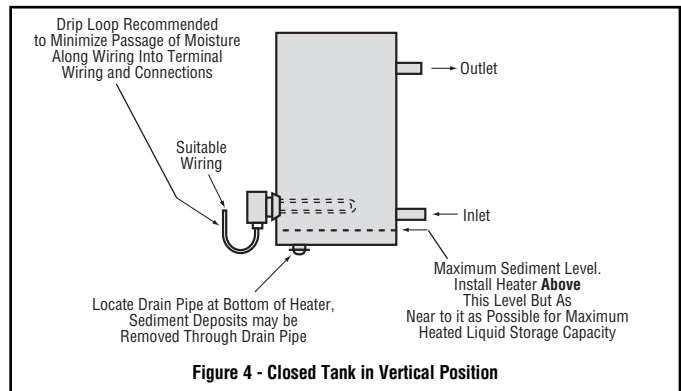

9. A drip loop is recommended to minimize passage of moisture from condensation along wiring into terminal box enclosure and connections.

⚠ WARNING

FIRE HAZARD. Since heaters are capable of developing high temperatures, extreme care should be taken to:

- A. Use explosion-resistant terminal enclosures in hazardous locations. See Chromalox catalog for selection of explosion-resistant terminal enclosure for hazardous locations.
- B. Avoid contact between heater and combustible materials.
- C. Keep combustible materials far enough away to be free of the effects of high temperatures.

⚠ WARNING

FREEZE HAZARD. This unit may be equipped with a thermowell for process control or over-temperature control. Do not allow moisture to accumulate in thermowell. Freezing temperatures can cause damage that may result in the heated medium leaking into terminal enclosure.

INSTALLATION (cont'd)

10. To prevent moisture accumulation in cryogenic applications or when heater is exposed to freezing temperatures:
 - A. Slope conduit away from enclosure (drip loop).
 - B. Seal all conduit openings to moisture/explosion resistant terminal enclosure.
 - C. Insulate terminal enclosure.
 - D. Fill thermowell(s) with silicone fluid when heater is mounted with terminal enclosure up.

BEFORE ENERGIZING

1. Check that the gasket is in place and the flange is securely bolted to the tank.
2. Check that power supply connections are made according to the wiring diagram. Also check for positive connection of all bus bars and power supply leads.

3. Check all bussing hardware is tightened to 20-25 in-lbs.
4. Check all bussing to element connections are tightened to 14-17 in-lbs.

⚠ WARNING

FIRE OR SHOCK HAZARD: Moisture accumulation in the element refractory material, element over-temperature, or sheath corrosion can cause ground fault to the element sheath, generating arcing and molten metal. Install Ground Fault Circuit-Interrupter (GFCI) to prevent personal injury or Equipment Ground Fault Protection to prevent property damage.

THERMOSTATS

1. Integrally mounted thermostats are available: single throw models.
2. Electrical rating of thermostats:

| Voltage | Thermostat Type | |
|---------|-----------------|------------|
| | T1 | T2 |
| 120 | 30 Amps | 30 Amps |
| 240 | 30 Amps | 30 Amps |
| 480 | Pilot Duty | Pilot Duty |

3. Thermostats may be connected directly to heaters that are rated within the electrical capacities specified. When the heater phase or amperage exceeds the contact rating of the thermostat, the heater should be controlled by a magnetic contactor with the thermostat wired for pilot duty. Refer to the thermostat instruction sheet packed with the heater.
4. If optional thermostat kit is purchased, please refer to instruction manual shipped with kit for proper bracket and thermostat mounting
5. **WARNING:** To maintain third party listing on an E4 housing, do not add any sparking device, such as a thermostat, inside the terminal enclosure.

WIRING

⚠ WARNING

ELECTRIC SHOCK HAZARD. Disconnect all power before installing or servicing heater. Failure to do so could result in personal injury or property damage. Heater must be installed by a qualified person in accordance with the National Electrical Code, NFPA 70.

⚠ WARNING

ELECTRIC SHOCK HAZARD. Any installation involving electric heaters must be performed by a qualified person and must be effectively grounded in accordance with the National Electrical Code to eliminate shock hazard.

1. Electric wiring to heater must be installed in accordance with the National Electrical Code, International Electric code and/or with local codes by a qualified person.
2. When element wattages are not equal, heaters must not be connected in series.
3. Electrical wiring to heater should be contained in rigid conduit or in sealed flexible conduit to keep corrosive vapors and liquids out of the terminal enclosure. If high humidity is encountered, the conduit should slope away from the heater.
4. If flexible cord is employed, a watertight connector should be used for entry of the cord into the terminal enclosure. Outdoor applications require liquid-tight conduit and connectors.
5. Bring the power line wires through the opening in the terminal box.
6. Heaters are prewired and tagged for easy installation of electrical wiring to the heater. Typical tagging of the individual circuits of Chromalox™ industrial flanged heaters are shown in the following tabulation:

| No. Circuits | Phase | Tagging |
|--------------|-------|---|
| 1 | 1 | L1 & L2 |
| 1 | 3 | L1, L2 & L3 |
| 2 | 3 | AL1, AL2, AL3 BL1, BL2 BL3 |
| 3 | 3 | AL1, AL2, & AL3 BL1, BL2 & BL3 CL1, CL2 & CL3 |

Note: Bussing tags are made with a non-conducting material. Please leave in place for proper identification during wiring.

7. Check for loose terminal connections and tighten if necessary. Made to order items are prewired and tagged at the factory. Wiring of made to order items may differ from those shown in the tabulation. **Carefully check voltage and phase on the heater nameplate and select either the appropriate wiring shown above or check for the appropriate wiring diagram in the heater terminal enclosure.** For reference purposes, some typical wiring diagrams are shown in the following figures.
8. The current carrying capacity of the power supply leads should exceed the heater amperage by at least 25%. Be sure to consider the ambient operating temperature and apply the appropriate correction factor to the ampacity rating of the wire. Heaters with the same voltage and wattage may be connected in series for operation at a higher voltage.

COMMON WIRING DIAGRAMS*

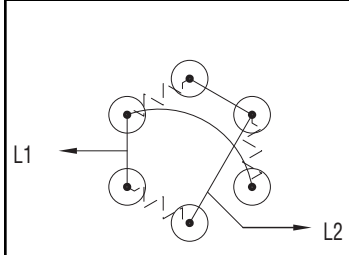
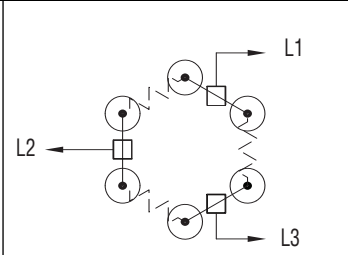
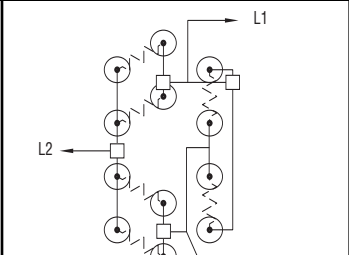
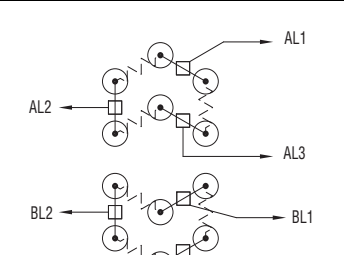
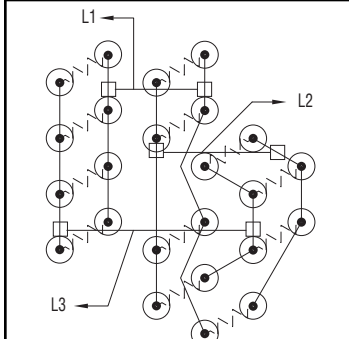
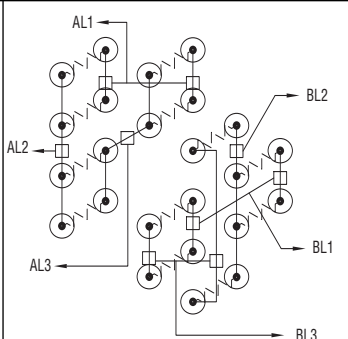
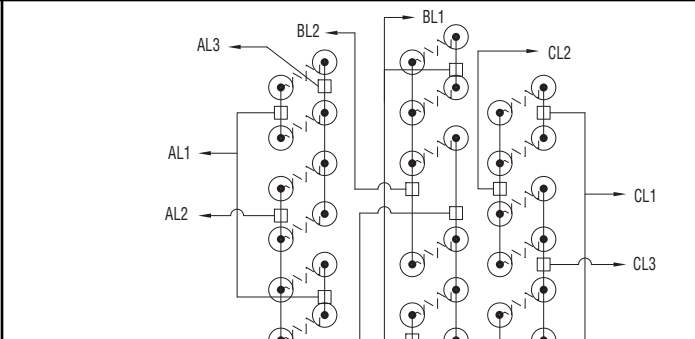
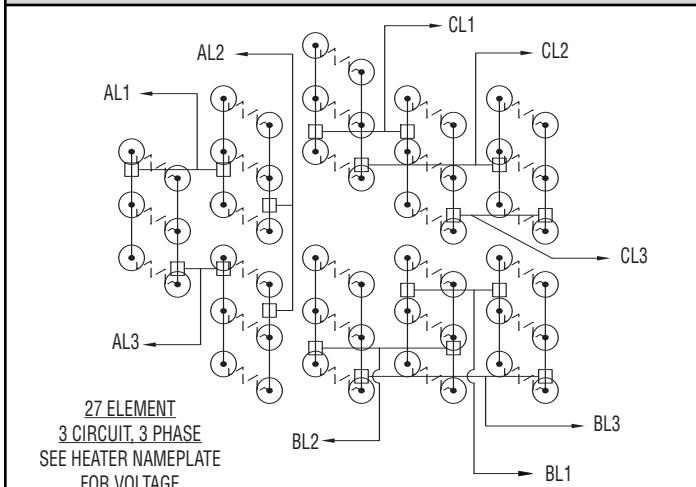
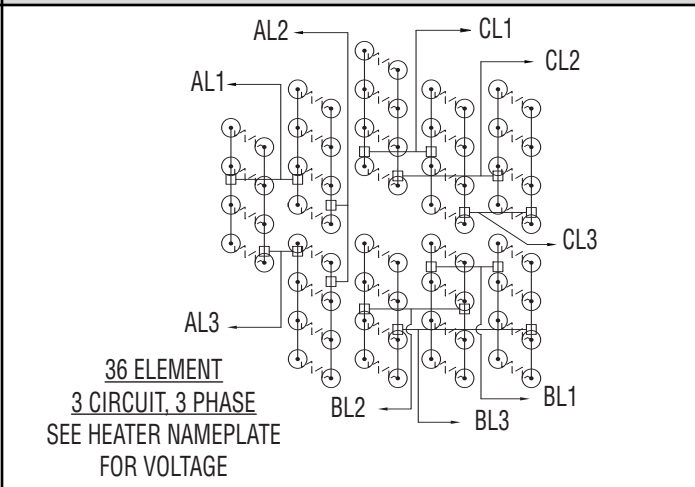
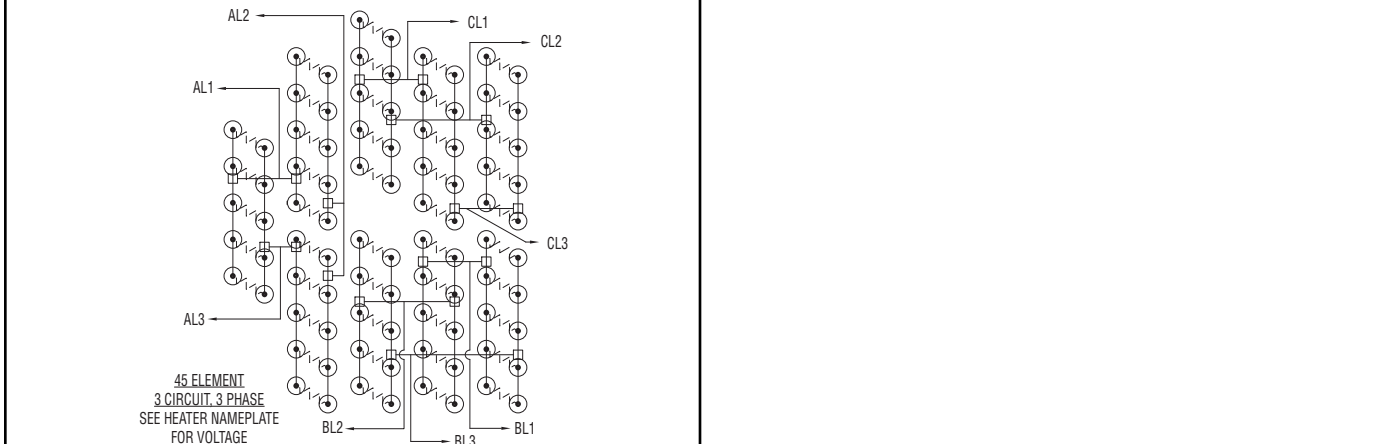
| TM Series - 3 Element (All sheath materials) | | TM Series - 6 Element (All sheath materials) | |
|--|--|---|---|
|  <p style="text-align: center; margin-top: 10px;">3 ELEMENT 1 CIRCUIT, 1 PHASE SEE HEATER NAMEPLATE FOR VOLTAGE</p> |  <p style="text-align: center; margin-top: 10px;">3 ELEMENT 1 CIRCUIT, 3 PHASE SEE HEATER NAMEPLATE FOR VOLTAGE</p> |  <p style="text-align: center; margin-top: 10px;">6 ELEMENT 1 CIRCUIT, 3 PHASE SEE HEATER NAMEPLATE FOR VOLTAGE</p> |  <p style="text-align: center; margin-top: 10px;">6 ELEMENT 2 CIRCUIT, 3 PHASE SEE HEATER NAMEPLATE FOR VOLTAGE</p> |
| TM Series - 12 Element (All sheath materials) | | TM Series - 18 Element (All sheath materials) | |
|  <p style="text-align: center; margin-top: 10px;">12 ELEMENT 1 CIRCUIT, 3 PHASE SEE HEATER NAMEPLATE FOR VOLTAGE</p> |  <p style="text-align: center; margin-top: 10px;">12 ELEMENT 2 CIRCUIT, 3 PHASE SEE HEATER NAMEPLATE FOR VOLTAGE</p> |  <p style="text-align: center; margin-top: 10px;">18 ELEMENT 3 CIRCUIT, 3 PHASE SEE HEATER NAMEPLATE FOR VOLTAGE</p> | |
| TM Series - 27 Element (All sheath materials) | | TM Series - 36 Element (All sheath materials) 208-600V | |
|  <p style="text-align: center; margin-top: 10px;">27 ELEMENT 3 CIRCUIT, 3 PHASE SEE HEATER NAMEPLATE FOR VOLTAGE</p> |  <p style="text-align: center; margin-top: 10px;">36 ELEMENT 3 CIRCUIT, 3 PHASE SEE HEATER NAMEPLATE FOR VOLTAGE</p> | | |
| TM Series - 45 Element (All sheath materials) | | | |
|  <p style="text-align: center; margin-top: 10px;">45 ELEMENT 3 CIRCUIT, 3 PHASE SEE HEATER NAMEPLATE FOR VOLTAGE</p> | | | |

*For other wiring configurations, please refer to unit drawing.

WIRING INSTALLATION

Wiring

Use only Type E4 or E2 terminal enclosures in hazardous location environments as applicable. The proper use of Type E4 or E2 terminal enclosures on electric heaters located in hazardous areas requires that all electrical wiring comply with National Electrical Code (NEC) and/or International Electric Code requirements for hazardous locations.

Wiring Entrance Locations

Flange sizes 6" or larger that use Chromalox E1 or E4 offer several convenient options for conduit wiring & location. The housing is equipped with two removable service entrance plates for installation of wiring. Any or all of the six sides can be used for wiring locations. Refer to exploded view drawing. The housing can also be rotated (by removal from flange) to allow for more position possibilities. To install service entrance holes, simply remove the side Allen screws and use the centering depression to drill the appropriate size hole. Reinstall the gasket(s), if applicable, and service entrance plates by tightening the Allen head screws to 4-5 in-lbs. The 'Octobox' style of housing can be removed for ease of access to element bussing or to better locate the power conduit(s) entry point. To accomplish, simply remove the Allen-head screws on the outside of the housing. When reinstalling, be sure to properly align gasket, if applicable, and tighten to 40-50 in-lbs.

Tip for reinstalling gaskets

Place Allen Head screws through metal covers and gently push gasket hole over the threaded screw. This will allow the gasket to stay in place while tightening the cover.

Maximum Temperatures

Safe operation in a hazardous location requires the maximum operating temperatures of all exposed surfaces of the heater including temperatures on the outside of the vessel, piping, flanges, screw plugs, enclosures and other heat conducting parts be limited. The flammable liquids, vapors or gases present determine the maximum

surface temperature permitted in any hazardous location. The end user or purchaser of the electric heating equipment is responsible for determining the proper classification of an area and for providing Chromalox with hazardous area specifications and requirements for proper equipment design. (NEC and IEC provide guidelines for evaluating and classifying hazardous locations.)

Safety Devices

Approved pressure and/or temperature limiting controls must be used on electric heaters and heating elements to ensure safe operation in the event of system malfunctions.

Note: Locations including hydrogen gas require additional conduit seals and thread engagement.

Terminal Housing, Exploded View - 'Octobox' Style

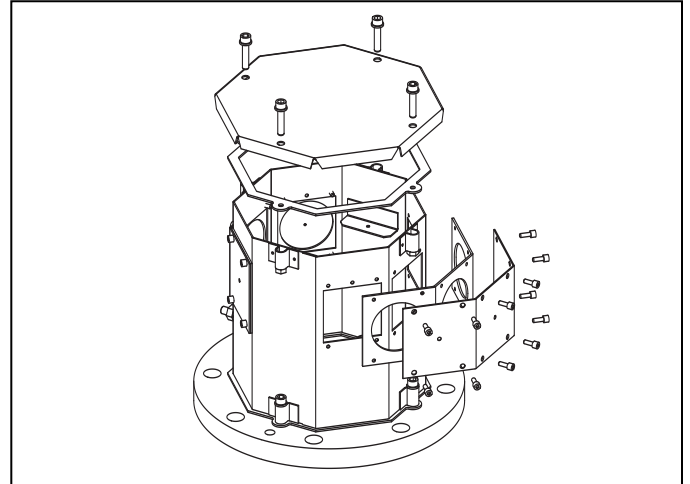

Third Party Certifications by Housing Style

| Model | Purpose | | North American Designation (s) | Canadian Designation (s) | European Designation (s) | International Designation (s) |
|---|---|-------------------------------|--|--|--|---|
| E1 | General Purpose | Generic Agency (s) Ratings | NEMA 1, NEC UL/CSAus General Duty Only | NEMA 1 IP32 CSA General Duty Only | IP32 CE: Manufacturer's Declaration General Duty Only | CE: Manufacturer's Declaration General Duty Only |
| E4* | Moisture Resistant Note: Temps over T3 (200°C) require stand-offs for third party listing. Refer to IECex & ATEX certifs. for stand-off dimensions | Generic Agency (s) Ratings | NEMA 4 UL / CSAus Class I Div. 2, Groups B, C, D Class II Division 2, Groups E, F: 200°C (T3) Group G 165°C (T3B) Class I Zone 2 AEx nA II T1 to T6 | NEMA 4 CSA Class I Div. 2, Groups B, C, D Class II Division 2, Groups E, F: 200°C (T3) Group G 165°C (T3B) Class I Zone 2 Ex nA II T1 to T6 | IP66 CE: Manufacturer's Declaration II 3 G Ex nA II T1 to T6 | IP66 CE: Manufacturer's Declaration Ex nA II T1 to T6 |
| E2 | Moisture/Explosion Resistant Note: Temps over T4 (135°C) require stand-offs for third party listing. Refer to IECex & ATEX certifs. for stand-off dimensions | Generic Agency (s) Ratings | Explosion Resistant CSAus Class I, Div. 1 Groups B,C & D Class II, Div. 1 Groups E, F & G Class I Zone 1 AEx d IIB + H2 T1 to T6 | Explosion Resistant CSA Class I, Div. 1 Groups B,C & D Class II, Div. 1 Groups E, F & G Class I Zone 1 Ex d IIB + H2 T1 to T6 | Explosion Resistant ATEX II 2 G EEx d IIB+H2 T1 to T6 | Explosion Resistant IECex Ex d IIB+H2 T1 to T6 |
| E5 Flange Size 3" - 8" 8" - 12" 12" - 18" | Moisture/Explosion Resistant ATEX IIC Labeling Reference CFP4 CFP8 CFP12 | Generic Agency (s) Ratings | | | ITS ATEX II 2 G EEx de IIC T1 to T6, 540°C, 600°C | IECex Ex de IIC T1 to T6 540°C, 600°C |

***WARNING:** Addition of a sparking device, such as a Thermostat, to an E4 housing will annul hazardous area rating.

ENCLOSURE STYLES

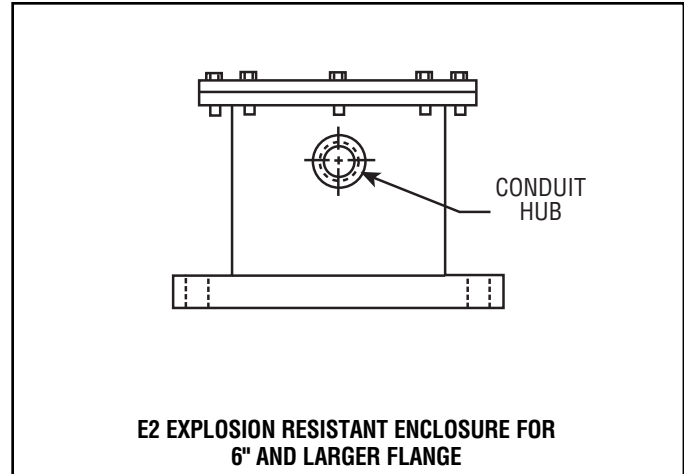
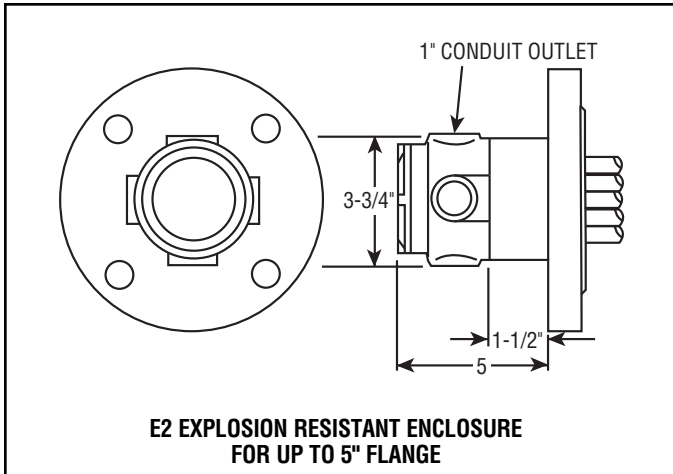
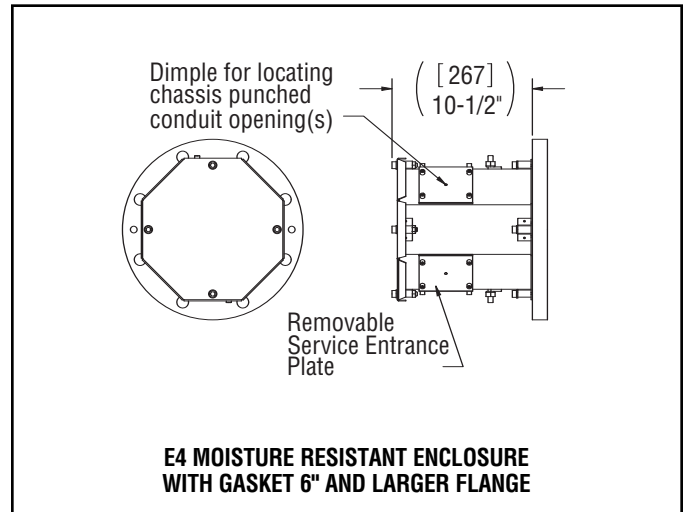
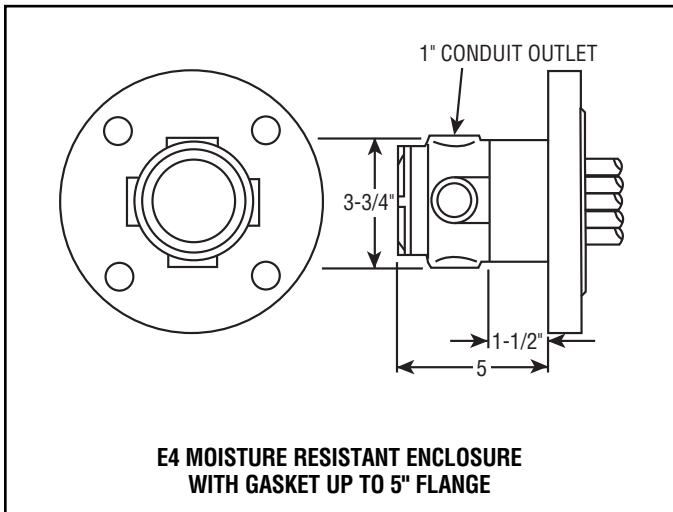
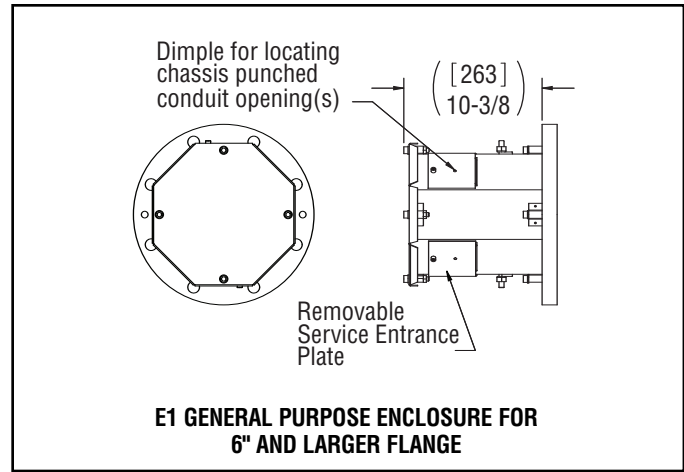
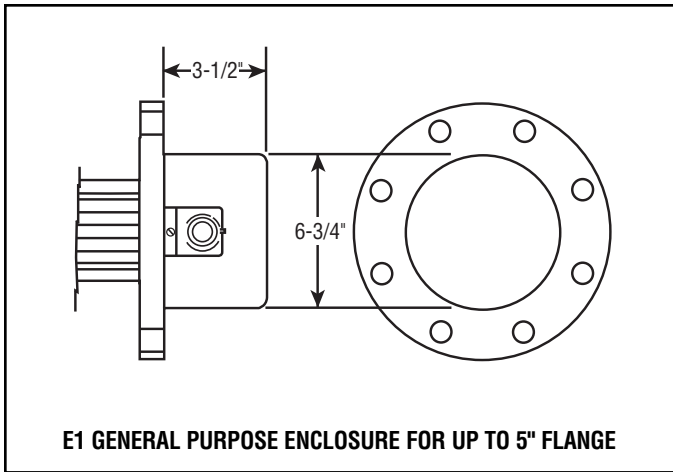

Note: These are typical enclosure styles. The heater purchased may vary slightly.

OPERATION

1. Do not operate heaters at voltages in excess of that stamped on the heater since excess voltage will shorten heater life.
2. Always maintain a minimum of 2" of liquid above the heated portion of the element to prevent exposure of the effective heated length. If the heater is not properly submerged, it may over-heat and shorten heater life. **DO NOT OPERATE HEATER IF DRY.**
3. Be sure all trapped air is removed from a closed tank. Bleed the air out of the liquid piping system and heater enclosure prior to energizing.
Note: The tank or heating chamber in closed tank systems must be kept filled with liquid at all times.
4. Keep heating elements above sediment deposits.
5. **Low Megohm Condition** — The refractory material used in electric heaters may absorb moisture during transit, storage or when subject to humid environments that will reduce the cold insulation resistance (low megohm). Low megohm may result in high leakage current to ground and nuisance trips of ground fault protection equipment. Normally, the megohm value increases after heat-up.

Typical insulation values are 5 megohm or greater on complete assemblies of unsealed elements or 20 megohm on individual unsealed elements. It is recommended that heaters with 1 megohm or less be dried out before applying full power. If dried properly low megohm will not effect heater life or efficiency.

To correct a low megohm condition, remove terminal enclosure cover, gaskets, and terminal hardware. Bake heaters in an oven at 300 to 350°F for several hours or preferably overnight.

An alternate procedure is to cycle the heater in 10 to 15 minute periods at low voltage until megohm values are normal. Sheath temperatures should not exceed 350°F.

Note: Low megohm on heating elements with epoxy or hermetic seals cannot be serviced in the field. Typical resistance values when sealed are 200 megohm or greater. Contact Chromalox service center at number listed.

When using an element sheath thermocouple, be sure to install flange with the imprinted "TOP" designation directly upward.

MAINTENANCE

⚠ WARNING

ELECTRIC SHOCK HAZARD. Disconnect all power before installing or servicing heater. Failure to do so could result in personal injury or property damage.

1. Heaters should be checked regularly for coatings and corrosion and cleaned if necessary.
2. The tank should be checked regularly for sediment around the heater as sediment can act as an insulator and shorten heater life.
Note: User is responsible for maintenance schedule based on their knowledge of the heated medium and operating conditions.
3. Remove any accumulated sludge deposits from heater and from tank.
4. Check for loose terminal connections and tighten if necessary.
5. If corrosion is indicated in the terminal enclosure, check terminal enclosure gasket and replace if necessary. Check conduit layout to correct conditions that allow moisture to enter the terminal enclosure.
6. Clean terminal ends of all contamination.
7. The heater can be protected from possible mechanical damage by placing a screen or grill around the elements.
8. Protect the terminal end of the heater from spray, condensation, dripping and vapors. A protective terminal enclosure should be used if the heater is to be subjected to these conditions.

9. If the heater is to be operated in the presence of explosive vapors or dust, an explosion resistant terminal enclosure must be provided.
10. Do not set the thermostats above the boiling point of the liquid. The boiling liquid could create a steam pocket which could cause the element(s) to overheat and burn out.
11. Periodically, remove the heater from the tank to inspect the elements for signs of corrosion and remove any deposits from the sheath. **BE SURE POWER IS DISCONNECTED BEFORE REMOVING ELEMENTS.**
12. Be sure the sheath material is compatible with the material being heated. Copper sheathed elements are used to heat water. Steel sheath elements are used to heat oil, alkaline, wax and other similar materials. Stainless steel and Incoloy sheathed elements are most often used for heating water and corrosive solutions. Check with the supplier of the material or factory for a recommendation of a suitable sheath material.
13. Make sure the watt-density of the heater is suitable for the material being heated. The velocity, viscosity, thermal conductivity of the material and operating temperature are all factors in determining the allowable watt-density of the element. Consult factory if in doubt about the proper watt-density for the heater in a particular application.
14. When heating liquids in a large tank, the use of several small heaters will provide more uniform heat distribution than a single large heater.

UNIT IDENTIFICATION

Chromalox Model Descriptions

Chromalox Flanged Immersion Heaters can be partially identified based on the standardized model build table listed below.

Model

| | | | | | | | | | | |
|-----------|------------------------------|--|---------------------|-------------|----------|-------------|------------|-----------|-----------------------------|--|
| TM | ANSI Flange Immersion Heater | | | | | | | | | |
| | Code | Element Sheath Material | | | | | | | | |
| | (Blank) | Copper | | | | | | | | |
| | O | Carbon Steel | | | | | | | | |
| | S | 304 Stainless Steel | | | | | | | | |
| | I | Incoloy 800 | | | | | | | | |
| | X | Other Material | | | | | | | | |
| | Code | Flange Material | | | | | | | | |
| | (Blank) | Carbon Steel | | | | | | | | |
| | S | 304 Stainless Steel | | | | | | | | |
| | X | Other Material | | | | | | | | |
| | Code | Baffled Flow | | | | | | | | |
| | (Blank) | No Baffles | | | | | | | | |
| | B | Baffled Flow | | | | | | | | |
| | Code | Number of Elements | | | | | | | | |
| | 03 | Three Heating Elements | | | | | | | | |
| | 06 | Six Heating Elements | | | | | | | | |
| | 12 | Twelve Heating Elements | | | | | | | | |
| | 18 | Eighteen Heating Elements | | | | | | | | |
| | 27 | Twenty-Seven Heating Elements | | | | | | | | |
| | 36 | Thirty-Six Heating Elements | | | | | | | | |
| | 45 | Forty-Five Heating Elements | | | | | | | | |
| | Code | Wattage | | | | | | | | |
| | 004P5 | 4.5 kW (use actual kilowatt in 3 digits) | | | | | | | | |
| | Code | Terminal Housing Style | | | | | | | | |
| | E1 | General Purpose | | | | | | | | |
| | E4 | Moisture Resistant | | | | | | | | |
| | E2 | Explosion / Moisture Resistant | | | | | | | | |
| | E5 | Explosion / Moisture Resistant - addition of Group IIC w/ Acetylene (IEC only) | | | | | | | | |
| | Code | Non-Standard Feature | | | | | | | | |
| | (Blank) | Catalog PCN item | | | | | | | | |
| | XX | Custom Feature | | | | | | | | |
| | Code | Voltage | | | | | | | | |
| | 208 | 208V | | | | | | | | |
| | 240 | 240V | | | | | | | | |
| | 380 | 380V | | | | | | | | |
| | 415 | 415V | | | | | | | | |
| | 480 | 480V | | | | | | | | |
| | 575 | 575V | | | | | | | | |
| | Code | Number of circuits | | | | | | | | |
| | 1 | One | | | | | | | | |
| | 2 | Two | | | | | | | | |
| | 3 | Three | | | | | | | | |
| | 4 | Four | | | | | | | | |
| | Code | Phase | | | | | | | | |
| | 1P | Single Phase | | | | | | | | |
| | 3P | Three Phase | | | | | | | | |
| | Code | Kilowatts | | | | | | | | |
| | 4.5 | kW | | | | | | | | |
| TM | I | - 03 | - 004P5 - E4 | 480V | 1 | - 3P | 4.5 | kW | Typical Model Number | |

Example of Final Model Description: TMI-03-004P5-E4 480V 1-3P 4.5kW

Note: Shaded sections of the model build table are not a finite list. Items such as Number of Elements, Wattage, Voltage, Circuits, and Phase should be adjusted to match design.

UNIT IDENTIFICATION (CONT'D.)

Labeling Descriptions

Specific model information such as the unique Chromalox part number, manufacturing date, third party certifications, etc. can be found by

using the diagram below. For additional information not contained here, please contact you local Chromalox Sales Office.

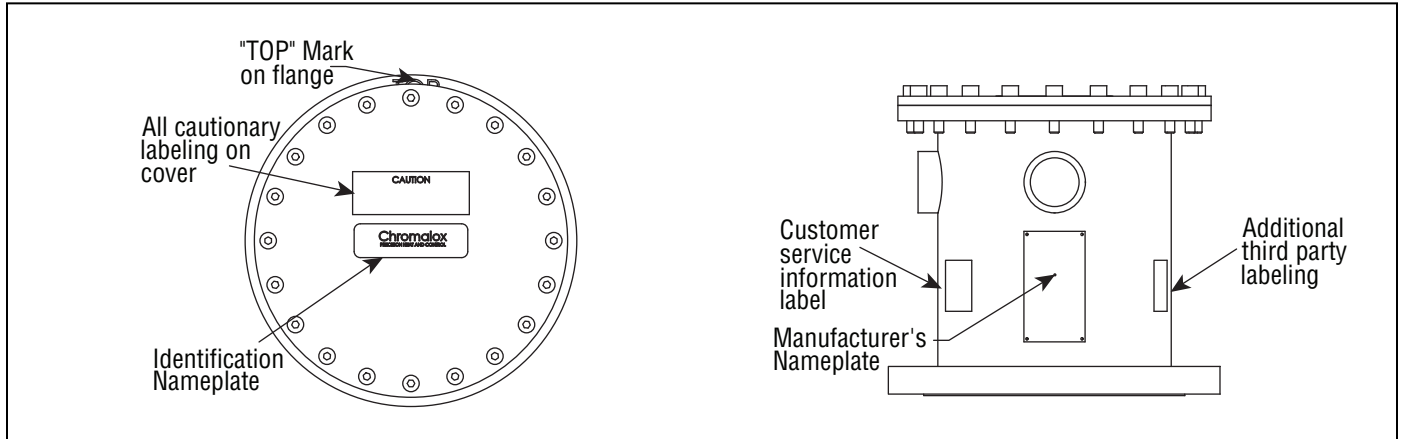

SPARE PARTS LIST FOR ANSI FLANGE HEATERS

| Flange Size | 3" | 5" | 6" | 8" | 10" | 12" | 14" |
|---|----------------|----------------|----------------|----------------|----------------|----------------|----------------|
| 150# ANSI Flange Gasket | 132-017222-015 | 132-017222-016 | 132-017222-005 | 132-017222-007 | 132-017222-009 | 132-017222-011 | 132-017222-013 |
| (1) Set of Flange Bolting & Nuts (rated 150LB*) | 168-306161-001 | 168-306161-002 | 168-306161-003 | 168-306161-004 | 168-306161-005 | 168-306161-006 | 168-306161-007 |
| Terminal Housing Cover (E1) | 080-013022-001 | 080-013063-001 | 080-305809-006 | 080-305809-008 | 080-305809-010 | 080-305809-012 | 080-305809-014 |
| Blank Service Entrance Plate (E1) | 027-014672-001 | 027-014672-001 | 080-305942-006 | 080-305942-008 | 080-305942-010 | 080-305942-012 | 080-305942-014 |
| (1) Set of Cover/Enclosure Bolts & Nuts (E1&E4) | N/A | N/A | 168-306161-008 | 168-306161-008 | 168-306161-008 | 168-306161-009 | 168-306161-009 |
| Terminal Housing Cover (E4) | N/A | N/A | 080-305809-006 | 080-305809-008 | 080-305809-010 | 080-305809-012 | 080-305809-014 |
| Blank Service Entrance Plate (E4) | N/A | N/A | 080-305807-006 | 080-305807-008 | 080-305807-010 | 080-305807-012 | 080-305807-014 |
| Service Entrance Plate Gasket (E4) | N/A | N/A | 132-305811-006 | 132-305811-008 | 132-305811-010 | 132-305811-012 | 132-305811-014 |
| Terminal Housing to Flange Gasket (E4) | N/A | N/A | 132-305810-006 | 132-305810-008 | 132-305810-010 | 132-305810-012 | 132-305810-014 |
| Terminal Housing Cover Gasket (E4) | N/A | N/A | 132-305810-006 | 132-305810-008 | 132-305810-010 | 132-305810-012 | 132-305810-014 |
| Terminal Housing Cover Gasket (E2) | 132-305967-004 | 132-305969-005 | 132-116937-040 | 132-116937-044 | 132-116937-047 | 132-116937-046 | 132-116937-050 |
| Terminal Housing Cover (E2) | 080-305967-003 | 080-305969-004 | 080-306161-021 | 080-306161-022 | 080-306161-023 | 080-306161-024 | 080-306161-025 |
| (1) Set of Cover/Enclosure Bolts (E2) | N/A | N/A | 168-306161-010 | 168-306161-011 | 168-306161-012 | 168-306161-013 | 168-306161-014 |
| Thermostat Install Kit (Parts to Mount Thermostat-E1) | N/A | N/A | 300-306012-009 | 300-306012-001 | 300-306012-010 | 300-306012-012 | 300-306012-014 |
| Thermostat Install Kit (Parts to Mount Thermostat-E4) | N/A | N/A | 300-306012-009 | 300-306012-001 | 300-306012-010 | 300-306012-012 | 300-306012-014 |
| Thermostat Install Kit (Parts to Mount Thermostat-E2) | N/A | 300-306012-005 | 300-306012-007 | 300-306012-008 | 300-306012-011 | 300-306012-013 | 300-306012-015 |
| Thermostat (0-100 deg. F) | N/A | 300-048518-012 | 300-048518-012 | 300-048518-012 | 300-048518-012 | 300-048518-012 | 300-048518-012 |
| Thermostat (60-250 deg. F) | N/A | 300-048518-013 | 300-048518-013 | 300-048518-013 | 300-048518-013 | 300-048518-013 | 300-048518-013 |
| Thermostat (200-550 deg. F) | N/A | 300-048518-014 | 300-048518-014 | 300-048518-014 | 300-048518-014 | 300-048518-014 | 300-048518-014 |
| Element Buss Bar 17" (User cut to Length) | N/A | N/A | 166-305730-009 | 166-305730-009 | 166-305730-009 | 166-305730-009 | 166-305730-009 |
| Line Buss Bar 17" (User cut to Length) | N/A | N/A | 166-305730-006 | 166-305730-006 | 166-305730-006 | 166-305730-006 | 166-305730-006 |
| Power Connection Bussing (hardware included) | N/A | N/A | 168-306161-015 | 168-306161-016 | 168-306161-017 | 168-306161-018 | 168-306161-019 |
| Circuit Labels (Pack of 9 unique labels-3 circuits) | | | | 168-306161-020 | | | |

* = Grade SA-325, oiled structural steel.

Limited Warranty:
Please refer to the Chromalox limited warranty applicable to this product at
<http://www.chromalox.com/customer-service/policies/termsofsale.aspx>.

Chromalox[®]
PRECISION HEAT AND CONTROL

2150 N. RULON WHITE BLVD., OGDEN, UT 84404
Phone: 1-800-368-2493 www.chromalox.com