

1 YEAR
WARRANTY



User's Guide



Shop online at

omega.com[®]
Ω OMEGA[®]

omega.com

e-mail: info@omega.com

For latest product manuals:
omegamanual.info

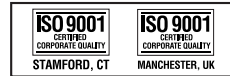

**Series FTB-1400-MD-LP
FTB-1400-SD-LP
FTB-1400-RD-LP**

Flow Monitor - Simplified Version



OMEGAnet® Online Service omega.com	Internet e-mail info@omega.com
--	--

Servicing North America:

U.S.A.: Omega Engineering, Inc., One Omega Drive, P.O. Box 4047
ISO 9001 Certified Stamford, CT 06907-0047
Toll-Free: 1-800-826-6342 Tel: (203) 359-1660
FAX: (203) 359-7700 e-mail: info@omega.com

Canada: 976 Bergar
Laval (Quebec), Canada H7L 5A1
Toll-Free: 1-800-826-6342 TEL: (514) 856-6928
FAX: (514) 856-6886 e-mail: info@omega.ca

For immediate technical or application assistance:

U.S.A. and Canada: Sales Service: 1-800-826-6342/1-800-TC-OMEGA®
Customer Service: 1-800-622-2378/1-800-622-BEST®
Engineering Service: 1-800-872-9436/1-800-USA-WHEN®

Mexico: En Español: 001 (203) 359-7803 FAX: (001) 203-359-7807
info@omega.com.mx e-mail: espanol@omega.com

Servicing Europe:

Benelux: Managed by the United Kingdom Office
Toll-Free: 0800 099 3344 TEL: +31 20 347 21 21
FAX: +31 20 643 46 43 e-mail: sales@omega.nl

Czech Republic: Frystatska 184
733 01 Karviná, Czech Republic
Toll-Free: 0800-1-66342 TEL: +420-59-6311899
FAX: +420-59-6311114 e-mail: info@omeshop.cz

France: Managed by the United Kingdom Office
Toll-Free: 0800 466 342 TEL: +33 (0) 161 37 29 00
FAX: +33 (0) 130 57 54 27 e-mail: sales@omega.fr

Germany/Austria: Daimlerstrasse 26
D-75392 Deckenpfronn, Germany
Toll-Free: 0 800 6397678 TEL: +49 (0) 7059 9398-0
FAX: +49 (0) 7056 9398-29 e-mail: info@omega.de

United Kingdom: OMEGA Engineering Ltd.
ISO 9001 Certified One Omega Drive, River Bend Technology Centre, Northbank
Irlam, Manchester M44 5BD England
Toll-Free: 0800-488-488 TEL: +44 (0)161 777-6611
FAX: +44 (0)161 777-6622 e-mail: sales@omega.co.uk

It is the policy of OMEGA Engineering, Inc. to comply with all worldwide safety and EMC/EMI regulations that apply. OMEGA is constantly pursuing certification of its products to the European New Approach Directives. OMEGA will add the CE mark to every appropriate device upon certification.

The information contained in this document is believed to be correct, but OMEGA accepts no liability for any errors it contains, and reserves the right to alter specifications without notice.

WARNING: These products are not designed for use in, and should not be used for, human applications.

CONTENTS

INTRODUCTION.....	4
SPECIFICATIONS	6
OPERATING THE MONITOR.....	7
BASIC PROGRAMMING MODE	7
PROGRAMMING.....	7
FTB-1400 Simplified 4-20 mA Programming	10
ADDITIONAL INPUT OPTIONS.....	12
TROUBLESHOOTING GUIDE	17
DEFAULT K-FACTOR VALUES.....	17
PART NUMBERING	18
REPLACEMENT PARTS.....	18

INTRODUCTION

The FTB-1400 Flow Monitor is a state-of-the-art, digital signal processing flow monitor, designed to provide the user with exceptional flexibility at a very affordable price. Though designed for use with Omega FTB-1400 flow meters, this display can be used with almost any flow meter producing a low amplitude AC output or contact closure signal(s).

This flow monitor is capable of accepting a low-level frequency input for calculating flow rate and total. These calculations can then be displayed in the desired units of measurement. All FTB-1400 flow monitors come pre-calibrated, from the factory, if ordered with an Omega FTB-1400 Flow Meter. If required, however, it can easily be re-configured in the field. The monitor's large 8 digit by .75" numeric liquid crystal display makes extended range viewing practical. The second 8 digit by .38" alphanumeric display provides for selectable units viewing in run mode and prompts for variables in program mode. Finally, the user can choose between displaying rate, total, or alternating between both rate and total.

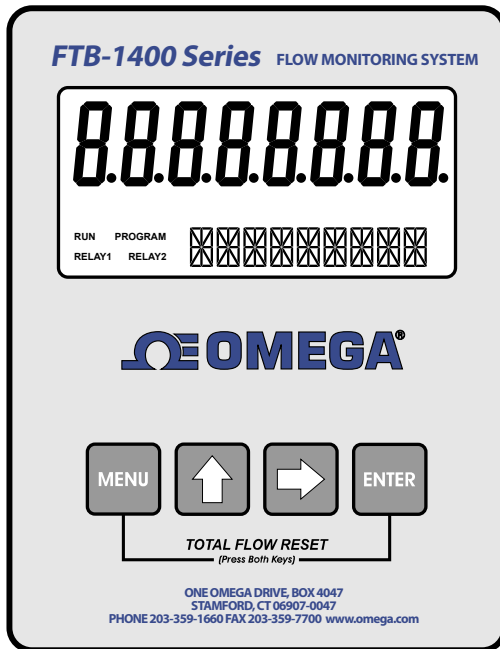

Figure 1: Flow Monitor Face

FEATURES

- Displays Rate and/or Total
- Large 0.75 Inch, 8 Digit Display for Easy Viewing
- Simple, Front Panel Programming
- Various Mounting Styles Available
- NEMA 4X Suitable for Outdoor Mounting
- Intrinsically Safe
- Microprocessor Based, Low Power Components
- 4-20 mA Loop Powered
- Automatic Decimal Point Locating
- Lead Zero Blinking
- Surface Mount Technology Use Throughout

SPECIFICATIONS

Power Supply:

4-20 mA loop power

Power Consumption:

25 mA (maximum)

Alphanumeric Rate and Total Display:

8 digit, .75" high numeric display

8 character, .38" high alphanumeric display

Fixed or toggle modes of operation for flow rate and totalizer display

Pulsed Output Signal:

Outputs one pulse for each increment of the least significant totalizer digit

Max. Voltage: 30 Vdc

Pulse Type: Opto-Isolated open collector transistor

Pulse Width ON State: 0.9 V drop @ 5.0 mA or 0.7 V drop @ 0.1 A

Magnetic Pick-up Inputs:

Frequency Range: 0 to 3500 Hz

Trigger Sensitivity: 30 mV p-p

Over Voltage Protected: ± 30 VDC

Frequency Measurement Accuracy: $\pm 0.1\%$ **Temperature Drift:** 50 ppm / °C (max)**Transient Overvoltages:** Category 3, in accordance with IEC664**Pollution Degree:** 2, in accordance with IEC664**Mounting Classification:**

Meter Mount: NEMA 4X Enclosure

Remote Mount: NEMA 4X Enclosure

Swivel Mount: NEMA 4X Enclosure

Environmental:

Operating Temperature: -22 °F to +158 °F (-30 °C to +70 °C)

Humidity: 0-90% Non-condensing

Units of Measure:

Gallons, Oil Barrels, Liters, Cubic Meters, MGal, Cubic FT, MCF, MMCF

Megltrs, Acre FT, Liq. Barrels, LBS, KGS

Time Intervals: Day, Hour, Minute, Second

OPERATING THE MONITOR

The monitor has two modes of operation referred to as the **RUN** mode and the **PROGRAM** mode. Both the run mode and the program mode display screen enunciators confirming the state of the monitor. A quick glance at the lower left hand corner of the LCD screen will confirm operating status. Normal operation will be in the **RUN** mode. To access the program mode, press the **MENU** button until the first programming screen is displayed. After programming the display with the necessary information, a lock out feature can be turned on to prevent unauthorized access or changing the meter's setup parameters.

BASIC PROGRAMMING MODE

Keys:

MENU – Switch between RUN and PROGRAM modes

UP Arrow – Scrolls through programming sub-menus in forward direction and increments numeric variables

RIGHT Arrow – Scrolls through programming sub-menus in reverse direction and moves the active digit to the right

ENTER – Used to enter sub-menus, save programming information and in the reset process

If your monitor was ordered with an Omega flow meter, the two components ship from the factory calibrated as a set. If the monitor is a replacement, the turbine's K-factor has changed, or the monitor is being used with some other pulse generating device, programming will be necessary.

PROGRAMMING

Each turbine flow meter is shipped with either a K-factor value or frequency data. If frequency data is provided, the data must be converted to a K-factor before programming. K-factor information, when supplied, can usually be found on the neck of the flow meter or stamped on the body. The K-factor represents the number of pulses per unit of volume. The K-factor will be needed to program the monitor.

ENTER PROGRAM MODE – Change to program mode by pressing the MENU button once. The mode indicator will change from RUN to PROGRAM.

NOTE: If any input value exceeds the meter's capabilities for that particular parameter, the LIMIT indicator will begin to flash indicating an invalid entry. Press ENTER once to return to the parameter's entry screen to reenter the value.

SELECT THE METER SIZE – At the METER prompt, press the ENTER button once. The current meter size number will begin to flash. Using the arrow keys, scroll through the size choices until you find the bore size of your meter. Press ENTER once to save the meter size choice.

NOTE: The meter connection size and the bore size are different. For example, many of the 1" NPT turbines have bore sizes that range from 3/8" up to 1". Be sure to use the correct bore size or the meter will report incorrect flows and totals.

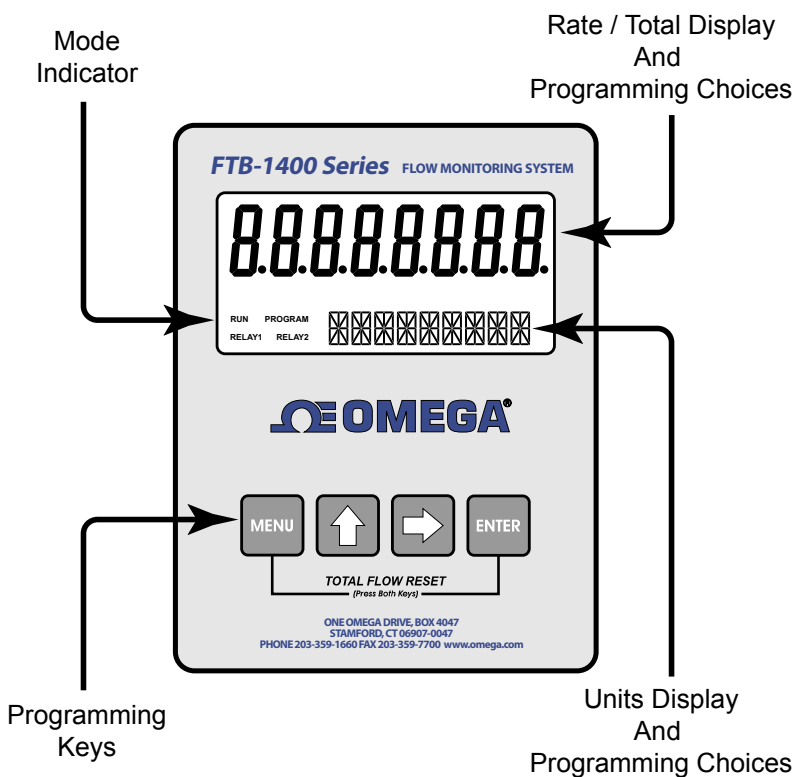

Figure 2: Flow Monitor Controls

ENTER THE METER'S K-FACTOR UNIT – Directly after the METER size is selected, the display's K-factor unit must be chosen. Use the UP arrow key to select your K-factor unit. For meters calibrated in gallons, use PUL/GAL (pulses per gallon); for meters calibrated in cubic meters, use PUL/M3 (pulses per cubic meter), etc. Press ENTER to save the K-factor unit and advance to the next parameter.

NOTE: Unless otherwise specified, Omega turbine flow meters are supplied with K-factors measured in pulses per gallon (PUL/GAL) which will automatically convert to your desired units of measure.

NOTE: The K-factor supplied with the meter or calculated from calibration data will be needed to complete the next step..

SELECT THE RATE/TOTAL UNITS OF MEASURE – The monitor allows the choice of five common rate/total units. The monitor shows the rate/total unit that the display is currently set for. If the current selection is correct, press the ENTER key once to advance to the next parameter. To change to an alternate unit, use the arrow keys to scroll to the desired rate unit and press ENTER to save the choice.

Selection	Rate	Total
GPM/GAL	Gallons per Minute	Gallons
LPM/LIT	Liters per Minute	Liters
M3PH/M3	Cubic Meters per Hour	Cubic Meters
M3PD/M3	Cubic Meters per Day	Cubic Meters
BPD/BBL	Oil Barrels per Day	Oil Barrels

NOTE: The total unit's output multiplier cannot be modified in the Simplified program level. This option is reserved in the Advanced program level.

SELECT THE DISPLAY FUNCTION – The monitor can display RATE or TOTAL or alternate between BOTH rate and total. At the DISPLAY prompt, press the ENTER key once. The monitor now shows the display mode currently in effect. If the current selection is correct, press the ENTER key to advance to the next parameter. To change to an alternate display mode, use the arrow keys to scroll to the desired display mode and press ENTER to save the choice.

A TEST function is also available in the Display Function sub-menu. With the test function selected, the display acts like a frequency counter and displays the raw input frequency being supplied to the frequency input terminals. This is very useful when troubleshooting flow problems.

TOTALIZER PULSE OUTPUT – The pulse output parameter can be either enabled or disabled. When enabled this output generates 20 mS duration pulse for every time the least significant digit of the totalizer increments. The amplitude of the pulse is dependent on the voltage level of the supply connected to the pulse output and is limited to a maximum 30 VDC.

FTB-1400 SIMPLIFIED 4-20 MA PROGRAMMING

FLOW 4mA SETTING – When the loop powered option is ordered, the flow rate that corresponds to 4mA must be set. Zero is default flow rate for this setting. If the current selection is correct, press the ENTER key once to advance to the next parameter. If adjustment is required, use the RIGHT arrow key to select the position of the number you wish to change. Then use the UP arrow key to increment the number. Once you have completed this step, press the ENTER key to advance to the next parameter.

FLOW 20mA SETTING – The flow rate that corresponds to 20mA must be set next. The turbine meter's maximum flow rate is the default value. If the current selection is correct, press the ENTER key once to advance to the next parameter. If adjustment is required, use the RIGHT arrow key to select the position of the number you wish to change. Then use the UP arrow key to increment the number. Once you have completed this step, press the ENTER key to advance to the next parameter.

4-20mA CALIBRATION – When ordered with a 4-20mA option, this menu item allows the fine adjustment of the 4-20mA output. The 4mA setting is typically between 35 and 50. To set the 4mA value, connect an ammeter in series with the loop power supply. At the 4mA OUT prompt, adjust the 4mA value to obtain a 4mA reading on the ammeter. The UP arrow key increments the value and the RIGHT arrow key decrements the value. When a steady 4mA reading is obtained on the ammeter, press the ENTER key to lock in this value and move to the 20mA adjustment. The 20mA adjustment is performed using the same procedure as the 4mA adjustment.

4-20mA TEST – The monitor contains a diagnostic routine that allows the simulation of mA values between 4 and 20 to check output tracking. At the 4-20TEST prompt the arrow keys change the simulated mA output in increments of 1 mA. The ammeter should track the simulated mA output. If a 4-20mA test is not necessary, pressing the ENTER key once will escape the testing at any time.

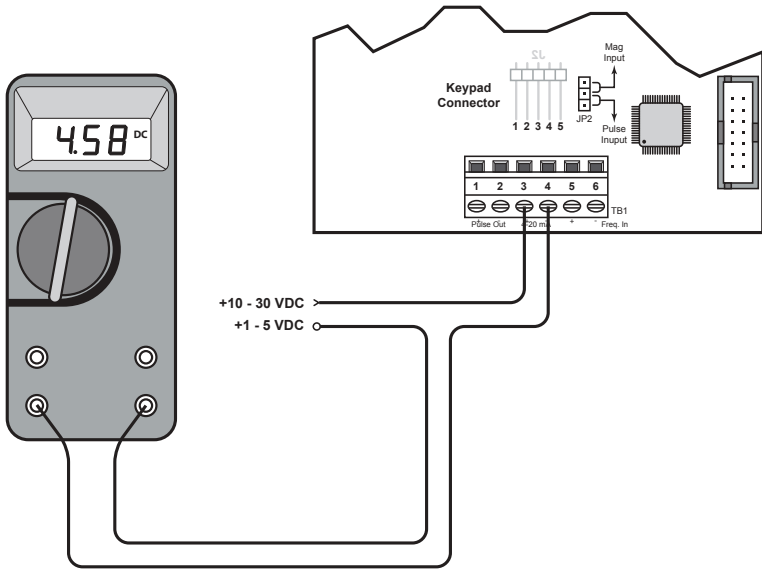

Figure 3: Typical Ammeter Connection

PASSWORD – Password protection prevents unauthorized users from changing programming information. Initially, the password is set to all zeros. To change the password, simply enter any 4 digit code using the arrow keys as previously described to enter the password value. Pressing ENTER once will store the password and take you back to the RST PSWD screen.

NOTE: This password will allow the operator to manually reset totals.

RST PSWD – The reset password screen allows the operator to enter any 4 digit code for the manual reset totals function.

RESET TOTAL – To reset the monitor total display, in RUN mode press the MENU and ENTER simultaneously until TOTAL RST starts to flash. The TOTAL RST will stop flashing and the display will return to the RUN mode at the conclusion of the reset procedure.

STORE TOTAL – The current total can be manually stored in the monitor's flash memory. Press and hold the ENTER key for 2 seconds. The display will respond with a flashing TOTALSVD and then return to the RUN mode.

AUTOMATIC STORE TOTAL – The monitor is equipped with a store total feature that works automatically, saving the current total to flash memory. The frequency of saves depends on the power supply option chosen.

Loop Powered: Once every ten minutes.

ADDITIONAL INPUT OPTIONS

The FTB-1400 Flow Monitor is capable of receiving magnetic pick-up input (small signal sine wave) or a contact closure input (pulse). Since Omega FTB-1400 Flow Meters utilize a magnetic pick-up, the monitor is shipped configured for magnetic pick-up input. To change to a contact closure input, remove JP2 from the top two pins and jumper them to the bottom two pins. See **Figure 4**.

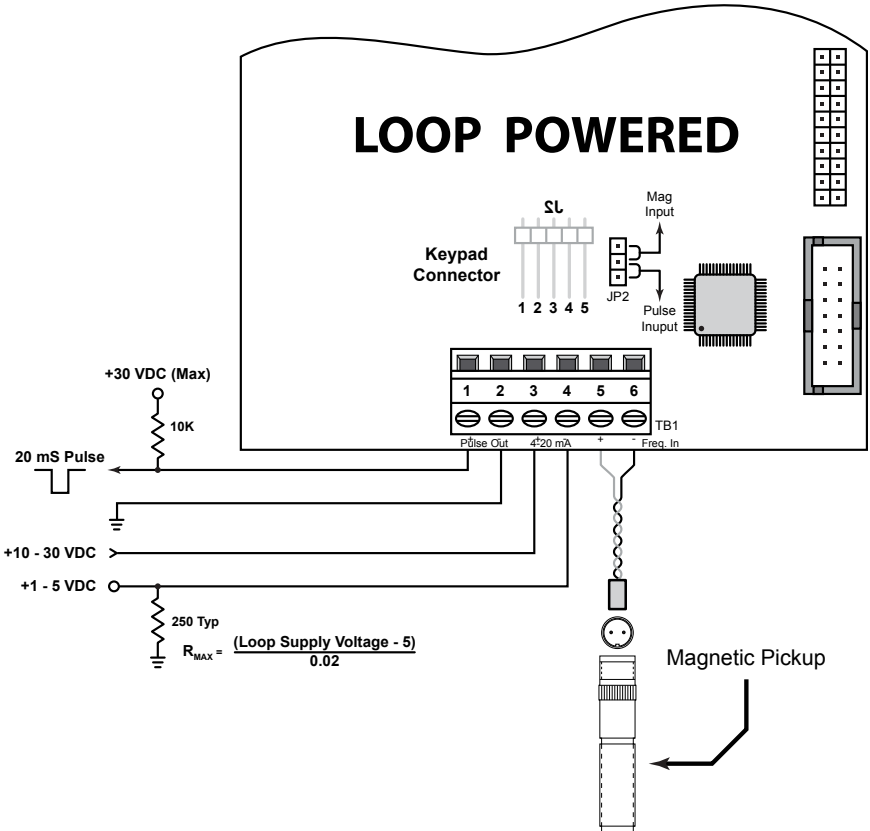

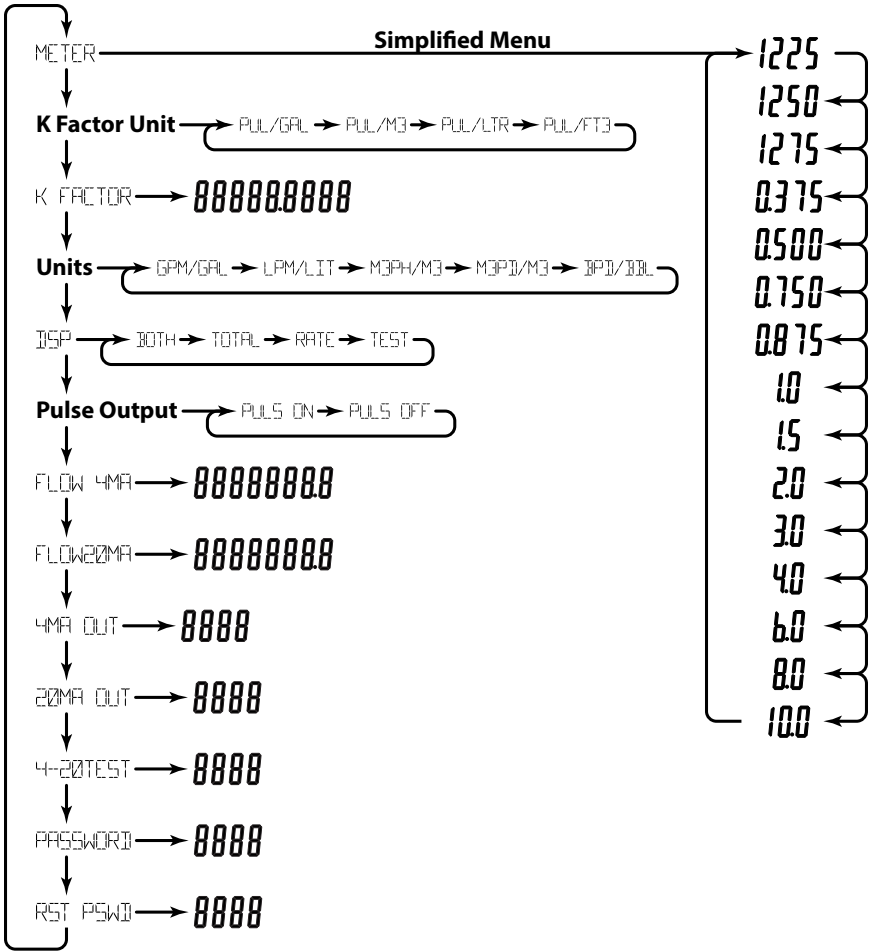
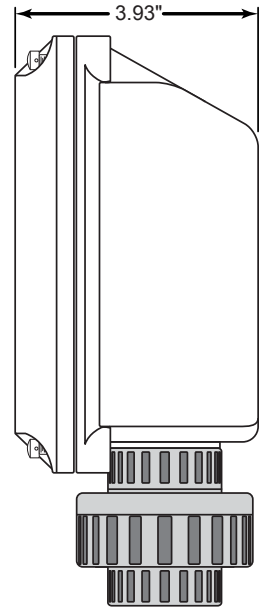
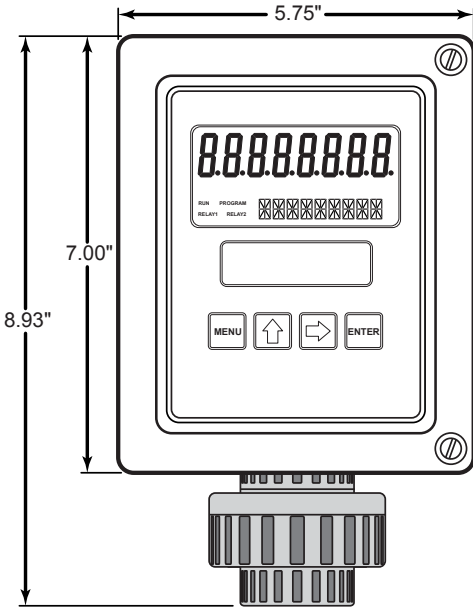
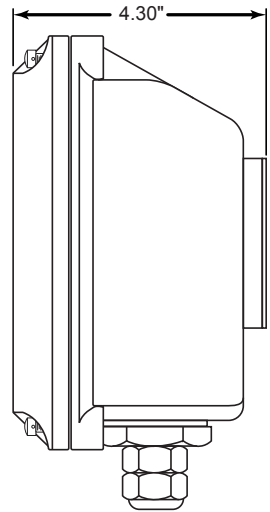
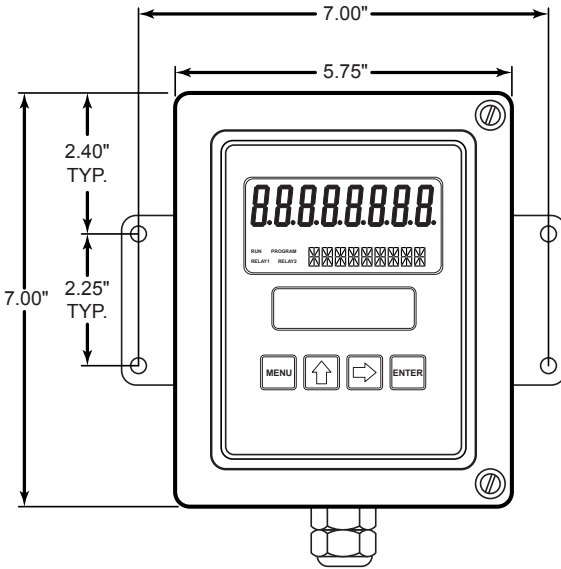

Figure 5: Basic Programming Menu



METER DISPLAY



REMOTE DISPLAY

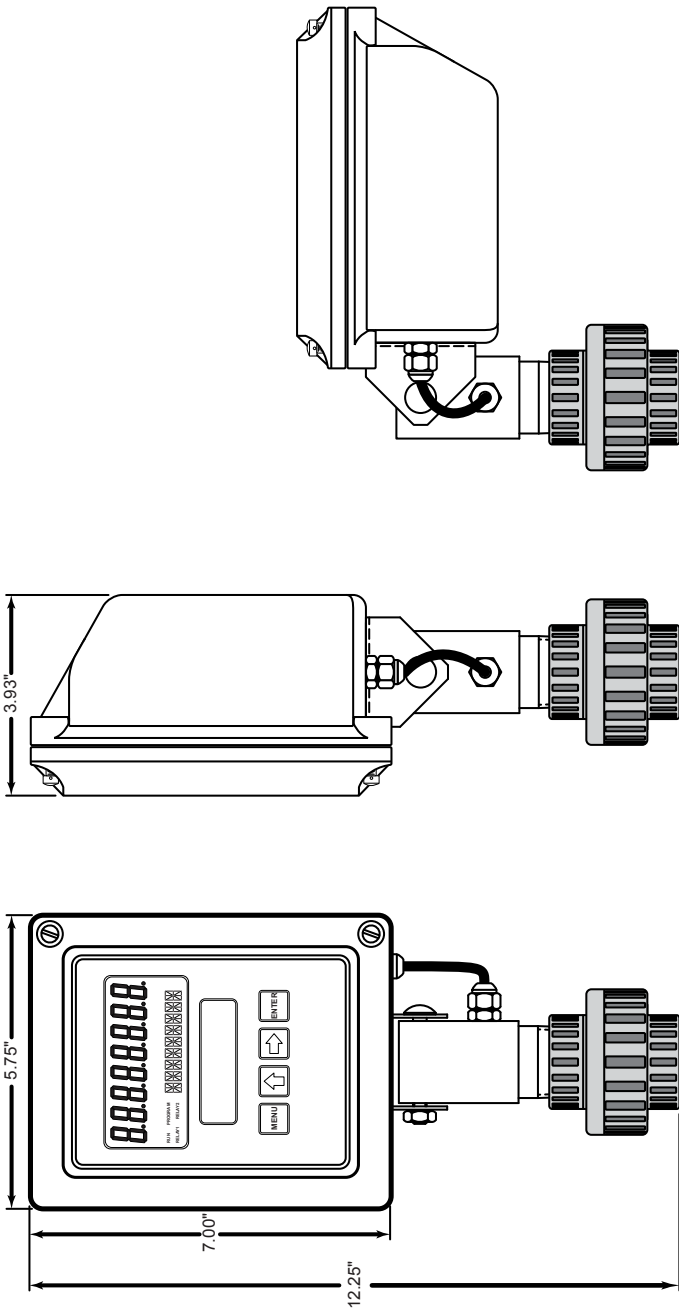

SWIVEL MOUNT
Figure 6: MOUNTING OPTIONS

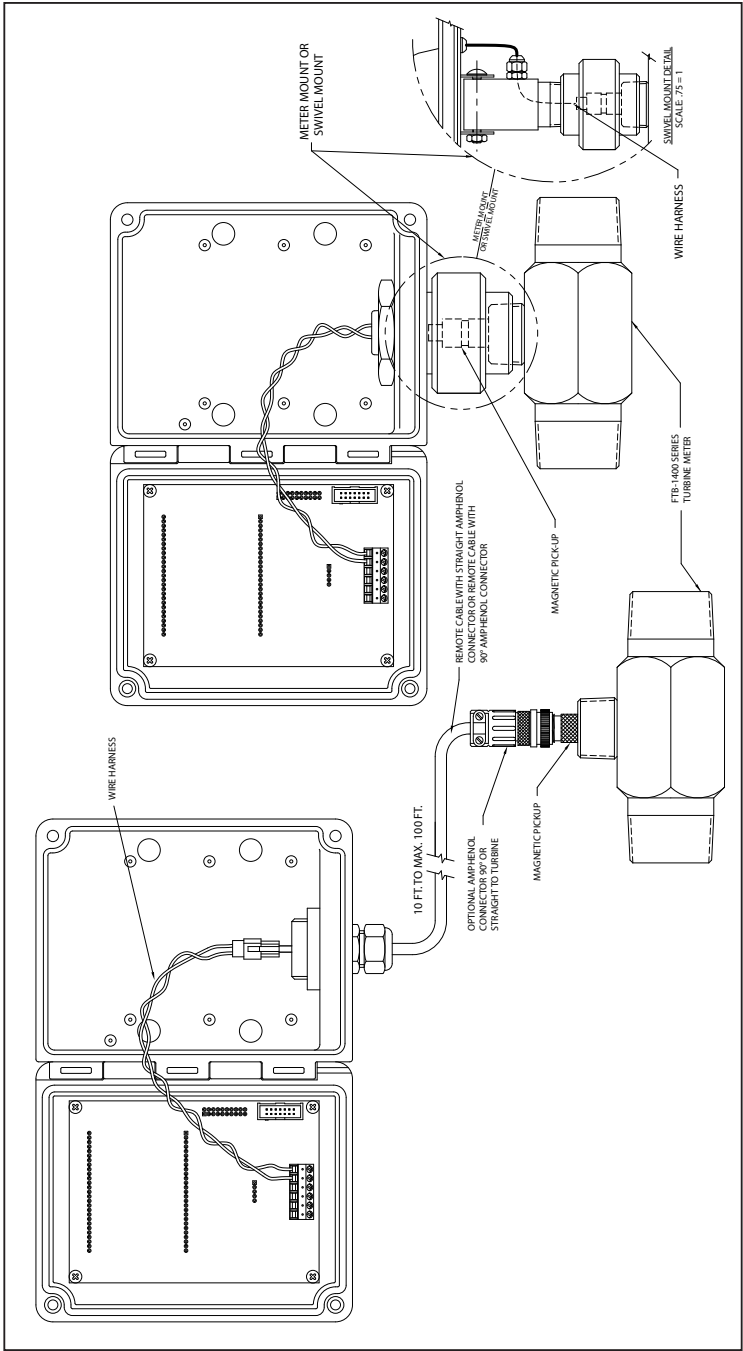

Figure 7: Installation Drawing

TROUBLESHOOTING GUIDE

Trouble	Remedy
No LCD Display	<ul style="list-style-type: none"> • Check power supply voltage. Should be between 10 and 30 Vdc.
No Rate or Total Displayed	<ul style="list-style-type: none"> • Check connection from meter pick-up to display input terminals. • Check turbine meter rotor for debris. Rotor should spin freely. • Check programming of flow monitor.
Flow Rate Display Interprets Reading Constantly	<ul style="list-style-type: none"> • This is usually an indication of external noise. Keep all AC wires separate from DC wires. • Check for large motors close to the meter pick-up. • Check for radio antenna in close proximity. • Try disconnecting the pick-up from the monitor pig tail. This should stop the noise.
Flow Rate Indicator Bounces	<ul style="list-style-type: none"> • This usually indicates a weak signal. Replace pick-up and/or check all connections. • Examine K-factor.

DEFAULT K-FACTOR VALUES

Meter Size	Default K-factor	Lower Limit	Upper Limit
0.375	20,000	16,000	24,000
0.500	13,000	10,400	15,600
0.750	2,750	2,200	3,300
0.875	2,686	2,148	3,223
1.000	870.0	696.0	1,044
1.500	330.0	264.0	396.0
2.000	52.0	41.6	62.0
3.000	57.0	45.6	68.0
4.000	29.0	23.2	35.0
6.000	7.0	5.6	8.0
8.000	3.0	2.4	4.0
10.000	1.6	1.3	2.0

PART NUMBERING

FTB-1400-XD-LP

Mounting Style

- M** - Meter Mount
- R** - Remote Mount
- S** - Swivel Mount

REPLACEMENT PARTS

Component	Part Number
Keypad	B260713
Pick-up Cable	B222-121
Desiccant Bag	B260630
PVC Union	B220016
PVC Reducer Bushing	B220056
Rubber Washer	B228207
Steel Lock Washer	B220018
Desiccant Shield	B280680
Cord Grip	B220103



WARRANTY/DISCLAIMER

OMEGA ENGINEERING, INC. warrants this unit to be free of defects in materials and workmanship for a period of **13 months** from date of purchase. OMEGA's WARRANTY adds an additional one (1) month grace period to the normal **one (1) year product warranty** to cover handling and shipping time. This ensures that OMEGA's customers receive maximum coverage on each product.

If the unit malfunctions, it must be returned to the factory for evaluation. OMEGA's Customer Service Department will issue an Authorized Return (AR) number immediately upon phone or written request. Upon examination by OMEGA, if the unit is found to be defective, it will be repaired or replaced at no charge. OMEGA's WARRANTY does not apply to defects resulting from any action of the purchaser, including but not limited to mishandling, improper interfacing, operation outside of design limits, improper repair, or unauthorized modification. This WARRANTY is VOID if the unit shows evidence of having been tampered with or shows evidence of having been damaged as a result of excessive corrosion; or current, heat, moisture or vibration; improper specification; misapplication; misuse or other operating conditions outside of OMEGA's control. Components in which wear is not warranted, include but are not limited to contact points, fuses, and triacs.

OMEGA is pleased to offer suggestions on the use of its various products. However, OMEGA neither assumes responsibility for any omissions or errors nor assumes liability for any damages that result from the use of its products in accordance with information provided by OMEGA, either verbal or written. OMEGA warrants only that the parts manufactured by the company will be as specified and free of defects. OMEGA MAKES NO OTHER WARRANTIES OR REPRESENTATIONS OF ANY KIND WHATSOEVER, EXPRESSED OR IMPLIED, EXCEPT THAT OF TITLE, AND ALL IMPLIED WARRANTIES INCLUDING ANY WARRANTY OF MERCHANTABILITY AND FITNESS FOR A PARTICULAR PURPOSE ARE HEREBY DISCLAIMED. LIMITATION OF LIABILITY: The remedies of purchaser set forth herein are exclusive, and the total liability of OMEGA with respect to this order, whether based on contract, warranty, negligence, indemnification, strict liability or otherwise, shall not exceed the purchase price of the component upon which liability is based. In no event shall OMEGA be liable for consequential, incidental or special damages.

CONDITIONS: Equipment sold by OMEGA is not intended to be used, nor shall it be used: (1) as a "Basic Component" under 10 CFR 21 (NRC), used in or with any nuclear installation or activity; or (2) in medical applications or used on humans. Should any Product(s) be used in or with any nuclear installation or activity, medical application, used on humans, or misused in any way, OMEGA assumes no responsibility as set forth in our basic WARRANTY/DISCLAIMER language, and, additionally, purchaser will indemnify OMEGA and hold OMEGA harmless from any liability or damage whatsoever arising out of the use of the Product(s) in such a manner.

RETURN REQUESTS/INQUIRIES

Direct all warranty and repair requests/inquiries to the OMEGA Customer Service Department. BEFORE RETURNING ANY PRODUCT(S) TO OMEGA, PURCHASER MUST OBTAIN AN AUTHORIZED RETURN (AR) NUMBER FROM OMEGA'S CUSTOMER SERVICE DEPARTMENT (IN ORDER TO AVOID PROCESSING DELAYS). The assigned AR number should then be marked on the outside of the return package and on any correspondence.

The purchaser is responsible for shipping charges, freight, insurance and proper packaging to prevent breakage in transit.

FOR **WARRANTY** RETURNS, please have the following information available BEFORE contacting OMEGA:

1. Purchase Order number under which the product was PURCHASED,
2. Model and serial number of the product under warranty, and
3. Repair instructions and/or specific problems relative to the product.

FOR **NON-WARRANTY** REPAIRS, consult OMEGA for current repair charges. Have the following information available BEFORE contacting OMEGA:

1. Purchase Order number to cover the COST of the repair,
2. Model and serial number of the product, and
3. Repair instructions and/or specific problems relative to the product.

OMEGA's policy is to make running changes, not model changes, whenever an improvement is possible. This affords our customers the latest in technology and engineering.

OMEGA is a registered trademark of OMEGA ENGINEERING, INC.

© Copyright 2009 OMEGA ENGINEERING, INC. All rights reserved. This document may not be copied, photocopied, reproduced, translated, or reduced to any electronic medium or machine-readable form, in whole or in part, without the prior written consent of OMEGA ENGINEERING, INC.

Where Do I Find Everything I Need for Process Measurement and Control? OMEGA...Of Course!

Shop online at omega.comSM

TEMPERATURE

- Thermocouple, RTD & Thermistor Probes, Connectors, Panels & Assemblies
- Wire: Thermocouple, RTD & Thermistor
- Calibrators & Ice Point References
- Recorders, Controllers & Process Monitors
- Infrared Pyrometers

PRESSURE, STRAIN AND FORCE

- Transducers & Strain Gages
- Load Cells & Pressure Gages
- Displacement Transducers
- Instrumentation & Accessories

FLOW/LEVEL

- Rotameters, Gas Mass Flowmeters & Flow Computers
- Air Velocity Indicators
- Turbine/Paddlewheel Systems
- Totalizers & Batch Controllers

pH/CONDUCTIVITY

- pH Electrodes, Testers & Accessories
- Benchtop/Laboratory Meters
- Controllers, Calibrators, Simulators & Pumps
- Industrial pH & Conductivity Equipment

DATA ACQUISITION

- Data Acquisition & Engineering Software
- Communications-Based Acquisition Systems
- Plug-in Cards for Apple, IBM & Compatibles
- Datalogging Systems
- Recorders, Printers & Plotters

HEATERS

- Heating Cable
- Cartridge & Strip Heaters
- Immersion & Band Heaters
- Flexible Heaters
- Laboratory Heaters

ENVIRONMENTAL MONITORING AND CONTROL

- Metering & Control Instrumentation
- Refractometers
- Pumps & Tubing
- Air, Soil & Water Monitors
- Industrial Water & Wastewater Treatment
- pH, Conductivity & Dissolved Oxygen Instruments