

1 YEAR
WARRANTY



User's Guide

Shop online at

omega.com[®]

Ω OMEGA[®]

omega.com

e-mail: info@omega.com

For latest product manuals:

omegamanual.info

ISO 9001
CERTIFIED
CORPORATE QUALITY
STAMFORD, CT

ISO 9001
CERTIFIED
CORPORATE QUALITY
MANCHESTER, UK

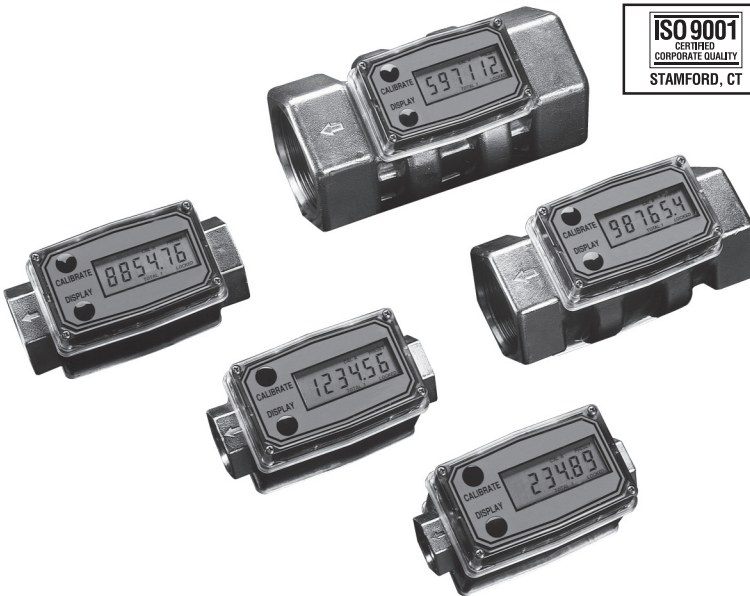

FTB790 SERIES **Turbine Flowmeters**



OMEGAnet® Online Service omega.com	Internet e-mail info@omega.com
---	---

Servicing North America:

U.S.A.: Omega Engineering, Inc., One Omega Drive, P.O. Box 4047
ISO 9001 Certified Stamford, CT 06907-0047
Toll-Free: 1-800-826-6342 Tel: (203) 359-1660
FAX: (203) 359-7700 e-mail: info@omega.com

Canada: 976 Bergar
Laval (Quebec), Canada H7L 5A1
Toll-Free: 1-800-826-6342 TEL: (514) 856-6928
FAX: (514) 856-6886 e-mail: info@omega.ca

For immediate technical or application assistance:

U.S.A. and Canada: Sales Service: 1-800-826-6342/1-800-TC-OMEGA®
Customer Service: 1-800-622-2378/1-800-622-BEST®
Engineering Service: 1-800-872-9436/1-800-USA-WHEN®

Mexico: En Español: 001 (203) 359-7803 FAX: (001) 203-359-7807
info@omega.com.mx e-mail: espanol@omega.com

Servicing Europe:

Benelux: Managed by the United Kingdom Office
Toll-Free: 0800 099 3344 TEL: +31 20 347 21 21
FAX: +31 20 643 46 43 e-mail: sales@omega.nl

Czech Republic: Frystatska 184
733 01 Karviná, Czech Republic
Toll-Free: 0800-1-66342 TEL: +420-59-6311899
FAX: +420-59-6311114 e-mail: info@omegashop.cz

France: Managed by the United Kingdom Office
Toll-Free: 0800 466 342 TEL: +33 (0) 161 37 29 00
FAX: +33 (0) 130 57 54 27 e-mail: sales@omega.fr

Germany/Austria: Daimlerstrasse 26
D-75392 Deckenpfronn, Germany
Toll-Free: 0 800 6397678 TEL: +49 (0) 7059 9398-0
FAX: +49 (0) 7056 9398-29 e-mail: info@omega.de

United Kingdom: OMEGA Engineering Ltd.
ISO 9001 Certified One Omega Drive, River Bend Technology Centre, Northbank
Irlam, Manchester M44 5BD England
Toll-Free: 0800-488-488 TEL: +44 (0)161 777-6611
FAX: +44 (0)161 777-6622 e-mail: sales@omega.co.uk

It is the policy of OMEGA Engineering, Inc. to comply with all worldwide safety and EMC/EMI regulations that apply. OMEGA is constantly pursuing certification of its products to the European New Approach Directives. OMEGA will add the CE mark to every appropriate device upon certification.

The information contained in this document is believed to be correct, but OMEGA accepts no liability for any errors it contains, and reserves the right to alter specifications without notice.

WARNING: These products are not designed for use in, and should not be used for, human applications.

TABLE OF CONTENTS

General Information.....	1
Product Description	2
Installation.....	3
Connections.....	3
Operations	4
Calibration.....	5
Maintenance	6
Troubleshooting	8
Specifications	9
Model Numbers	17
Parts & Accessories.....	19
Warranty/Disclaimer.....	21
Return Requests/Inquiries.....	21

GENERAL INFORMATION

This manual will assist you in installing and maintaining your FTB790 Series turbine meter and associated display electronics. The turbine meters can be purchased with or without the display electronics. (See Figure 1)

Figure 1

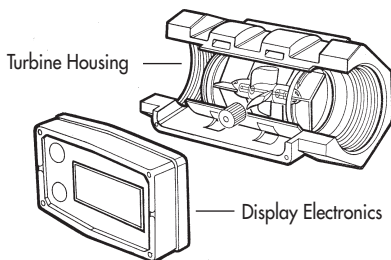

When purchased with the display electronics, optional accessory modules are available for field installation. Information on these accessories is contained in separate manuals. Calibration details using the display electronics are given in this manual.

When purchased without the display (Suffix - ND) an optional field installable Pulse Output Module (FLSC790-P-ND) is available and described in a separate manual.

For best results, take the time to fully acquaint yourself with all information about all components of your FTB790 Series Turbine Meter System prior to installation and use. If you need assistance, contact the Omega Flow Application Department.



This symbol is used throughout the manual to call your attention to safety messages.

WARNING

Warnings alert you to the potential for personal injury.

CAUTION

Cautions call your attention to practices or procedures which may damage your equipment.

Notes give information that can improve efficiency of operations.

It is your responsibility to make sure that all operators have access to adequate instructions about safe operating and maintenance procedures.

Read Me!

For your safety, review the major warnings and cautions below before operating your equipment.

WARNING

The apparatus enclosure may contain aluminum and is considered to constitute a potential risk of ignition by impact or friction. Care must be taken into account during installation and use to prevent impact or friction.

WARNING

Part of the enclosure is constructed from plastic. To prevent the risk of electrostatic sparking the plastic surface should only be cleaned with a damp cloth.

1. This equipment is approved to handle only fluids which are compatible with all wetted materials.
2. When measuring flammable liquids, observe precautions against fire or explosion.

3. When handling hazardous liquids, always follow the liquid manufacturer's safety precautions.
4. When working in hazardous environments, always exercise appropriate safety precautions.
5. Always dispose of used cleaning solvents in a safe manner according to the solvent manufacturer's instructions.
6. During turbine removal, liquid may spill. Follow the liquid manufacturer's safety precautions for clean up of minor spills.
7. Do not blow compressed air through the turbine.
8. Do not allow liquids to dry inside the turbine.
9. Handle the rotor carefully. Even small scratches or nicks can affect accuracy.
10. When tightening the turbine, use a wrench only on the wrench flats.
11. For best results, always verify accuracy before use.

Liquids flow through the turbine housing causing an internal rotor to spin. As the rotor spins, an electrical signal is generated in the pickup coil. The electrical signal provides the output necessary to operate the on-board display electronics for local indication directly on the turbine or one of several accessory modules that transmit the signal to external equipment.

Upon receipt, examine your meter for visible damage. The turbine is a precision measuring instrument and should be handled as such. Remove the protective plugs and caps for a thorough inspection. If any items are damaged or missing, contact OMEGA Customer Service.

Make sure the turbine model meets your specific needs. Refer to the Specifications Section and confirm the following:

1. The flowrate is within the limits of your model.
2. The liquid is compatible with the turbine's wetted components.
3. The system's pressure does not exceed the turbine's maximum pressure rating.

Information specific to your particular turbine, including serial number, model number, manufacturing date, and K-factor is etched into the surface of the turbine. On Models FTB791, FTB792, and FTB793 find the etched information on the side of the turbine. On Models FTB794 and FTB795 the information is etched on a wrench flat.

SN = Serial Number, a 7-8 digit number that identifies this particular turbine.

MOD = Model number

KF = K-Factor given in pulses per gallon (PPG).

DOM = Date of Manufacture indicating the week and year of manufacture.

For your future reference, it might be useful to record this information in the manual in case it becomes unreadable on the turbine.

PRODUCT DESCRIPTION

FTB790 Series Turbines are identified by the internal diameter of the inlet and outlet.

- FTB791 – 1/2 inch (Mid Flow)
- FTB792 – 3/4 inch (Mid Flow)
- FTB793 – 1 inch (Mid Flow)
- FTB794 – 1-1/2 inch (High Flow)
- FTB795 – 2 inch (High Flow)

Each of these turbines are designed to work with on-board display electronics and/or with one of several accessory modules that can interface to a wide variety of reporting and collecting devices.

The CMOS microprocessor-based electronics have extremely low power requirements and data retention capabilities in both RAM and ROM. Information is clearly displayed on a large 6-digit LCD readout with two-point floating decimal for totals from .01 to 999,999. All operations are easily accessed with the two buttons on the front panel.

INSTALLATION

All Series FTB790 turbines are designed to measure flow in only one direction. The direction is indicated by the arrow cast-molded in the turbine outlet. If the opposite direction is desired, and you are using on-board display electronics, rotate the display electronics 180 degrees prior to installation.

Flow altering devices such as elbows, valves, and reducers can affect accuracy. The following recommended guidelines are given to enhance accuracy and maximize performance. Distances given here are minimum requirements; double them for desired straight pipe lengths.

Upstream from the turbine, allow a minimum straight pipe length at least 10 times the internal diameter of the turbine. For example, with the FTB793 turbine, there should be 10 inches (25.4 cm) of straight pipe immediately upstream. The desired upstream straight pipe length is 20 inches (50.8 cm).

Downstream from the turbine, allow a minimum straight pipe length at least 5 times the internal diameter of your turbine. For example, with the FTB793 turbine, there should be 5 inches (12.7 cm) of straight pipe immediately downstream. The desired downstream distance is 10 inches (25.4 cm).

A typical back pressure of 5 to 50 PSI (0.34 to 3.4 bar) will prevent cavitation. Create back pressure by installing a control valve on the downstream side of the meter at the proper distance detailed above.

Foreign material in the liquid being measured can clog the turbine's rotor and adversely affect accuracy. If this problem is anticipated or experienced, install screens to filter impurities from incoming liquids.

Models FTB791, FTB792, FTB793

Maximum Particulate Size

Inches:	0.005
Microns:	125
Mesh:	55
Standard Sieve:	125 μm
Alternative Sieve:	No. 120

Models FTB794 and FTB795

Maximum Particulate Size

Inches:	0.018
Microns:	500
Mesh:	28
Standard Sieve:	500 μm
Alternative Sieve:	No. 35

All Series FTB790 turbines, except -TRI, -ISO and -HP, are Factory Mutual Approved and carry a Class 1, Division 1 Approval for hazardous environments. They are tested and calibrated at the factory using state-of-the-art calibration procedures and test equipment.

To ensure accurate measurement, remove all air from the system before use. To purge the system of air:

1. Ensure some back pressure on the turbine.
2. Open the discharge valve or nozzle and allow fluid to completely fill the system. Make sure the stream is full and steady.
3. Close the discharge valve or nozzle.
4. Start normal operations.

Each turbine contains a removable back coverplate. Leave the coverplate installed unless accessory modules specify removal.

CONNECTIONS

1. Threaded – Seal all threads with an appropriate sealing compound. Make sure the compound does not intrude into the flow path. Tighten the turbine onto the fittings. Use a wrench only on the wrench flats.

Tri-Grip – Insert a gasket between the turbine and the mating fitting. Determine the gasket material based on the operating conditions and type of fluid used. Fasten with the appropriate clamp. Tighten clamp to manufacturer's specifications.
2. Make sure the flow arrow on the outlet is pointed in the direction of the flow.

NOTE: If connecting to new male threads, burrs and curls can adversely effect accuracy. Correct the problem prior to

turbine installation.

It is strongly recommended that accuracy be verified prior to use. To do this, remove all air from the system, measure an exact known volume into an accurate container, and verify the volume against the readout or recording equipment. If necessary, use a correction factor to figure final volume. For best results, accuracy should be verified periodically as part of a routine maintenance schedule.

The display electronics is normally installed on the turbine housing at the factory unless ordered without it.

If for any reason the display electronics need to be mounted on your turbine, simply mount the display on the turbine with the four screws at the corners of the faceplate. Make sure the seal is fully seated before tightening the screws.

If you ordered the FTB790 Series turbine with an accessory module, please review and thoroughly understand all installation instructions before proceeding.

Avoid electronically “noisy” environments. Install at least 6 inches (15.2 cm) away from motors, relays, or transformers.

OPERATIONS

All operations are reflected in the LCD readout. The large center digits indicate amounts, where smaller words or “icons” located above and below indicate specific information regarding totals, flow, calibration and units of measure.

Activate the Meter

The computer is on continuously and always ready to perform. The computer is powered by field replaceable batteries. When display becomes dim, faded or the low battery message appears (see below), the batteries need to be replaced. Reference the Maintenance Section for details.

LobAtt

Batch and Cumulative Totals

The computer maintains two totals. The Cumulative Total provides continuous measurement and cannot be manually reset. The Batch Total can be reset to measure flow during a single use. The Cumulative Total is labeled TOTAL 1, Batch Total is labeled TOTAL 2 BATCH.

When the Cumulative Total reaches a display reading of 999,999 the computer will highlight an X10 icon. This indicates to the operator that a zero must be added to the 6 digits shown. When the next rollover occurs, the computer will highlight an X100 icon. This indicates to the operator that two zeroes must be added to the 6 digits shown.

Press the DISPLAY button briefly to switch between the TOTAL 1, TOTAL 2 BATCH and FLOWRATE. Press DISPLAY briefly to display the TOTAL 2 BATCH. Hold the DISPLAY button for 3 seconds to reset the Batch Total to zero.

When fluid is flowing through the meter, a small propeller icon is highlighted.

Flowrate Feature

To use this feature, press and release DISPLAY button until FLOWRATE icon appears. The factory set time base will be highlighted to the right of FLOWRATE (M = Minutes, H = hours, D = days). When FLOWRATE is invoked, the display will be indicating rate of flow.

Factory and Field Calibration

All calibration information is visible to the user as icons on the top line of the display, above the numeric digits.

All units are configured with a “factory” calibration. Both gallons and liters are available (“GL” or “LT” will be displayed). While holding the CALIBRATE button, briefly press DISPLAY to toggle between gallons and liters. This factory calibration (indicated with FAC) is permanently programmed into the computer and is not user adjustable.

NOTE: Your computer may have other units of measure programmed into it. If so, holding the CALIBRATE button and momentarily pressing the DISPLAY button will toggle through all factory set units. Other possible units are: IGL (imperial gallon), QT (quart), CF (cubic feet), CM (cubic meter), BL (42 gal. barrel), CC (cubic centimeter) or OZ (ounce).

Switching between different units will not corrupt the Total's contents. For example, in GL mode, the computer totalizes 10.00 gallons, if the user switches to LT mode, the display will read 37.85 liters (the same volume, different unit).

The "field" calibration may be set by the user, and can be changed or modified at any time using the calibration procedure described in the Calibration Section. Totals or flowrate derived from the field calibration are invoked when the FAC icon is no longer visible on the top line of the display.

CALIBRATION

Verify Accuracy Before Beginning Field Calibration

For the most accurate results, dispense at a flowrate which best simulates your actual operating conditions. Avoid "dribbling" more fluid or repeatedly starting and stopping the flow. This can result in less accurate calibrations.

Make sure you meet the meter's minimum flowrate requirements:

1/2 inch meter	1 GPM (3.8 LPM)
3/4 inch meter	2 GPM (7.5 LPM)
1 inch meter	5 GPM (18.8 LPM)
1-1/2 inch meter	10 GPM (37.5 LPM)
2 inch meter	20 GPM (76 LPM)

The use of a uniformly dependable, accurate calibration container is recommended for the most accurate results. Due to high flowrate, it is strongly recommended that calibration be completed with a combination of volume and weight using fine resolution scales. For best results, the meter should be installed and purged of air before field calibration.

Field Calibration with Computer Display

Field Calibration and Factory Calibration are defined in the Operation Section. Factory calibration settings are programmed into each computer during manufacturing, using standard test solvent at 70° F (21° C). Settings are correct for light liquids such as water, gasoline or diesel. Readings using the Factory Calibration (FAC) may not be accurate in some situations, for example, "heavy" liquids such as motor oil under extreme temperature conditions, non-standard plumbing configurations or with fluids other than water.

For improved accuracy under such conditions, the computer allows for "field" calibration, that is, user entry of custom calibration parameters. A "single point" calibration may yield acceptable accuracy when used in a non-standard application.

Field Calibration Procedures (Dispense/Display Method)

1. To field calibrate, press and hold the CALIBRATE and DISPLAY buttons for about 3 seconds until you see FLdCAL. Release both buttons and you will see dd000.0. You are now in the field calibration mode.
2. Dispense a known amount of fluid at a flowrate representative of the application. Any amount between 000.1 and 999.9 units can be used. Display will count up while fluid is flowing through the meter.
3. The DISPLAY button can then be pushed to select the digit location and the CALIBRATE button can be pushed to scroll the desired value at the blinking position. Edit the amount shown with the value that was dispensed above. Values from 000.1 to 999.9 can be entered.
4. When satisfied with the value, press both CALIBRATE and DISPLAY buttons simultaneously. CALend will be displayed and unit will go back to normal operation, less the FAC (factory calibration) icon.

- The meter will now be operating with a custom calibration number unique to the above dispense procedure. No unit of measure (gallon, liter, etc.) icon will be highlighted

NOTE: To return to factory calibration (FAC), press and hold both CALIBRATION and DISPLAY buttons for about 3 seconds, until FACAL is displayed. Then release buttons. Unit should return to normal operation and FAC icon visible

NOTE: If the field calibration mode is entered and NO fluid is dispensed, then upon leaving, the computer will use data from the last successful field calibration.

MAINTENANCE

Verify Accuracy

Before use, check the turbine's accuracy and verify calibration.

- Make sure there is no air in the system.
- Measure an exact known volume into an accurate container.
- Verify the volume against the readout or recording equipment.

NOTE: If necessary, use a correction factor to figure final volume.

For best results, accuracy should be verified periodically as part of a routine maintenance schedule.

Remove the Turbine

⚠ WARNING

During turbine removal, liquid may spill. Follow the liquid manufacturer's safety precautions for clean up of minor spills.

- Ensure all liquid is drained from the turbine. Wear protective clothing as necessary.
- Loosen both ends of the turbine. Use a wrench only on the turbine's wrench flats.
- If the turbine is not immediately installed again, cap lines as necessary.

Replace Internal Parts

- Remove the turbine from the system as detailed above.

NOTE: Carefully notice the orientation of all internal parts as they are removed, especially the orientation of the rotor to the flow direction arrow. (See Figure 2)

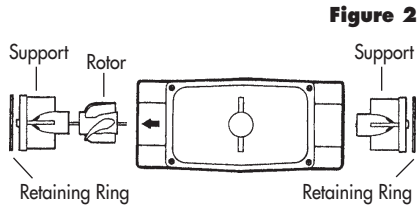

Figure 2

- Carefully clean residue off all parts. Remove internal parts as detailed above. Note orientation carefully for correct assembly. Internal parts can be soaked for 10-15 minutes in compatible cleaning solutions. Use a soft brush or small probe to *carefully* remove residue from the rotor.
- Using a small tool such as a screwdriver or awl, gently pry one retaining ring from its groove. Remove the support. If necessary, use needle nose pliers. Little or no force should be required.
- Carefully remove the rotor.

⚠ CAUTION

Handle the rotor carefully. Even small scratches or nicks can affect accuracy.

- Turn the turbine over and remove the other retaining ring. Remove the other support.
- Clean, as detailed below, or discard as necessary.
- Replace one support and retaining ring. Parts should drop easily into place with little or no force.
- Install the rotor. Make sure the wide end of the rotor's blades faces the flow direction. (See Figure 3)

Figure 3

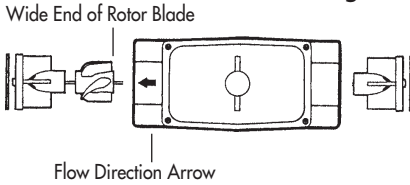

9. Turn the turbine over and drop the second support into place. Put the final retaining ring into position.
10. Reinstall the turbine, purge the system of air, and verify accuracy before use.

Clean the Turbine

During use, the turbine should be kept full of liquid to ensure that drying does not occur inside the turbine. If drying or caking should occur, the rotor will stick or drag, affecting accuracy. To determine if the rotor is stuck or dragging, gently blow air through the meter and listen for the quiet whir of the rotor.

CAUTION

Never blow compressed air through the meter. It could damage the rotor.

1. Remove the turbine from the system following the directions above.

WARNING

Follow the liquid manufacturer's instructions for the disposal of contaminated cleaning solvents.

2. When the rotor turns freely, assemble and install it again following the instructions above.

Display Electronics

The display electronics are powered by lithium batteries which provide at least four years of actual use. If the meter's readout should become dim, blank or the low battery message appears (see below), the batteries should be replaced. Replacement batteries can be ordered from the factory. See details in the Parts Section.

When batteries are disconnected or fail, values in Batch and Cumulative Totals will remain. Factory and Field Calibration Curves are retained in the meter's computer when power is lost.

It is strongly recommended that battery check and terminal cleaning be a part of a routine maintenance schedule. Battery terminals should be cleaned annually. Batteries can be replaced without removing the meter from the piping system.

Replacing the Batteries

1. Remove the corner screws from the meter face and lift the display electronics from the turbine.
2. Remove the batteries.
3. Check the battery terminals and remove any corrosion.
4. Install the new batteries and make sure the positive posts are positioned correctly. When the batteries are installed correctly, the computer powers on automatically and the readout displays information.
5. Make sure the seal is fully seated before placing the computer electronics on the turbine. Tighten the four screws.

TROUBLESHOOTING

Symptom	Probable Cause	Corrective Action
Meter is not accurate	<ol style="list-style-type: none"> 1. Field Calibration not performed properly 2. Factory Calibration not suitable for liquid being measured 3. Meter operated below minimum flowrate 4. Meter partially clogged with dried liquid 5. Turbine bearings partially clogged with dried liquid 6. Sealant material wrapped around rotor 7. Installed too close to fittings 8. Installed too close to motors or electrically “noisy” environment 9. Improper connections to recording device 10. Accuracy needs verification 	<p>Field calibrate again or select Factory Calibration.</p> <p>Perform a Field Calibration according to Calibration Section.</p> <p>Increase flowrate.</p> <p>Remove meter. Clean carefully. Make sure rotor spins freely.</p> <p>Remove meter. Clean carefully. Make sure rotor spins freely.</p> <p>Remove meter. Make sure rotor spins freely.</p> <p>Install correctly.</p> <p>Install correctly.</p> <p>Check all electrical connections. Reference appropriate installation instructions.</p> <p>Complete normal accuracy verification procedures. Repeat periodically.</p>
Readout faded or blank	<ol style="list-style-type: none"> 1. Batteries weak, dead, or not connected 2. Display electronics defective 	<p>Remove display electronics. Check and replace batteries if necessary.</p> <p>Contact the factory.</p>
Normal flowrate but meter does not count (Meter comes on when DISPLAY button pushed)	<ol style="list-style-type: none"> 1. Field Calibration not performed correctly 2. Rotor stuck or damaged 3. Sealant material wrapped around rotor 4. Display electronics defective 	<p>Field Calibrate again or select Factory Calibration.</p> <p>Remove meter. Make sure rotor spins freely.</p> <p>Remove meter. Make sure rotor spins freely.</p> <p>Contact the factory.</p>
Reduced flowrate and meter does not count (Meter comes on when DISPLAY button pushed)	<ol style="list-style-type: none"> 1. Meter clogged with dried liquids 2. Below minimum flowrate 	<p>Remove meter. Clean carefully. Make sure rotor spins freely.</p> <p>Increase flow.</p>

SPECIFICATIONS - STAINLESS STEEL - NPT

All data on Models FTB791, FTB792, and FTB793 determined with 1 centipoise stoddard solvent test fluid at 70° F (21° C). Data on Models FTB794 and FTB795 is determined with water at 70° F (21° C).

Models Size	FTB791 1/2 in.	FTB792 3/4 in.	FTB793 1 in.	FTB794 1-1/2 in.	FTB795 2 in.
Linear Flow Range					
Gallons/minute (GPM)	1-10	2-20	5-50	10-100	20-200
Liters/minute (LPM)	3.8-37.9	7.6-75.7	18.9-190	38-380	76-760
Maximum Flow					
Gallons/minute (GPM)	15	30	75	150	300
Liters/minute (LPM)	56.8	113.6	284	568	1,136
Meters/second	0.2-3.2	0.2-3.7	0.28-5.7	0.24-4.8	0.29-5.8
Maximum Pressure Drop in 10:1 Range					
PSIG	8	7.5	5	4	4
bar	0.55	0.5	0.34	0.28	0.28
Frequency Range in Linear Flow Range	45-450 Hz	37-370 Hz	45-475 Hz	35-350 Hz	33-330 Hz
Connections					
NPT Female Inlet/Outlet Size	1/2 in.	3/4 in.	1 in.	1-1/2 in.	2 in.
Wrench Size:					
Inch	1-1/16 in.	1-5/16 in.	1-5/8 in.	2-3/8 in.	3 in.
Millimeter	27 mm	33 mm	41 mm	60 mm	75 mm
Weight*					
Pounds	1.8 lbs.	2.0 lbs.	2.4 lbs.	4.0 lbs.	6.3 lbs.
Kilograms	0.8 kg	1.0 kg	1.1 kg	1.8 kg	2.9 kg

* Display electronics add 0.2 lbs. (0.1 kg) to total weight.

SPECIFICATIONS - STAINLESS STEEL - TRI

All data on Models FTB791-TRI, FTB792-TRI, and FTB793-TRI determined with 1 centipoise stoddard solvent test fluid at 70° F (21° C). Data on Models FTB794-TRI and FTB795-TRI is determined with water at 70° F (21° C).

NOTE: -TRI Models are not FM approved.

Models Size	FTB791-TRI 1/2 in.	FTB792 -TRI 3/4 in.	FTB793 -TRI 1 in.	FTB794 -TRI 1-1/2 in.	FTB795 -TRI 2 in.
Linear Flow Range					
Gallons/minute (GPM)	1-10	2-20	5-50	10-100	20-200
Liters/minute (LPM)	3.8-37.9	7.6-75.7	18.9-190	38-380	76-760
Maximum Flow					
Gallons/minute (GPM)	15	30	75	150	300
Liters/minute (LPM)	56.8	113.6	284	568	1,136
Maximum Pressure Drop in 10:1 Range					
PSIG	8	7.5	5	4	4
bar	0.55	0.5	0.34	0.28	0.28
Frequency Range in Linear Flow Range	45-450 Hz	37-370 Hz	45-475 Hz	35-350 Hz	33-330 Hz
Connections					
Tri-Grip Clamp Size	3/4 in.	1 in.	1 1/2 in.	2 in.	2-1/2 in.
Weight*					
Pounds	1.8 lbs.	2.2 lbs.	2.5 lbs.	4.0 lbs.	5.8 lbs.
Kilograms	0.8 kg	1.0 kg	1.2 kg	1.8 kg	2.6 kg

* Display electronics add 0.2 lbs. (0.1 kg) to total weight.

SPECIFICATIONS - STAINLESS STEEL - HP

All data on Models FTB791-HP, FTB792-HP, and FTB793-HP determined with 1 centipoise stoddard solvent test fluid at 70° F (21° C). Data on Models FTB794-HP and FTB795-HP is determined with water at 70° F (21° C).

NOTE: -HP Models are not FM approved.

Models Size	FTB791-HP 1/2 in.	FTB792-HP 3/4 in.	FTB793-HP 1 in.	FTB794-HP 1-1/2 in.	FTB795-HP 2 in.
Linear Flow Range					
Gallons/minute (GPM)	1-10	2-20	5-50	10-100	20-200
Liters/minute (LPM)	3.8-37.9	7.6-75.7	18.9-190	38-380	76-760
Maximum Flow					
Gallons/minute (GPM)	15	30	75	150	300
Liters/minute (LPM)	56.8	113.6	284	568	1,136
Maximum Pressure Drop in 10:1 Range					
PSIG	8	7.5	5	4	4
bar	0.55	0.5	0.34	0.28	0.28
Maximum Operating Pressure					
PSIG	3000	3000	3000	3000	3000
bar	207	207	207	207	207
Frequency Range in Linear Flow Range	45-450 Hz	37-370 Hz	45-475 Hz	35-350 Hz	33-330 Hz
Connections (Female Inlet/Outlet)					
NPT	1/2 in.	3/4 in.	1 in.	1-1/2 in.	2 in.
Wrench Size:					
Inch	1-1/16 in.	1-5/16 in.	1-5/8 in.	2-3/8 in.	3 in.
Millimeter	27 mm	33 mm	41 mm	60 mm	75 mm
Weight*					
Pounds	1.8 lbs.	2.0 lbs.	2.4 lbs.	4.0 lbs.	6.3 lbs.
Kilograms	0.8 kg	1.0 kg	1.1 kg	1.8 kg	2.9 kg

* Display electronics add 0.2 lbs. (0.1 kg) to total weight.

SPECIFICATIONS - STAINLESS STEEL - ISO

All data on Models FTB791-ISO, FTB792-ISO, and FTB793-ISO determined with 1 centipoise stoddard solvent test fluid at 70° F (21° C). Data on Models FTB794-ISO and FTB795-ISO is determined with water at 70° F (21° C).

NOTE: -ISO Models are not FM approved.

Models Size	FTB791-ISO 1/2 in.	FTB792-ISO 3/4 in.	FTB793-ISO 1 in.	FTB794-ISO 1-1/2 in.	FTB795-ISO 2 in.
Linear Flow Range					
Gallons/minute (GPM)	1-10	2-20	5-50	10-100	20-200
Liters/minute (LPM)	3.8-37.9	7.6-75.7	18.9-190	38-380	76-760
Maximum Flow					
Gallons/minute (GPM)	15	30	75	150	300
Liters/minute (LPM)	56.8	113.6	284	568	1,136
Maximum Pressure Drop in 10:1 Range					
PSIG	8	7.5	5	4	4
bar	0.55	0.5	0.34	0.28	0.28
Maximum Operating Pressure					
PSIG	3000	3000	3000	3000	3000
bar	207	207	207	207	207
Frequency Range in Linear Flow Range	45-450 Hz	37-370 Hz	45-475 Hz	35-350 Hz	33-330 Hz
Connections (Female Inlet/Outlet)					
ISO	Rc 1/2	Rc 3/4	Rc 1	Rc 1-1/2	Rc 2
Wrench Size:					
Inch	1-1/16 in.	1-5/16 in.	1-5/8 in.	2-3/8 in.	3 in.
Millimeter	27 mm	33 mm	41 mm	60 mm	75 mm
Weight*					
Pounds	1.8 lbs.	2.0 lbs.	2.4 lbs.	4.0 lbs.	6.3 lbs.
Kilograms	0.8 kg	1.0 kg	1.1 kg	1.8 kg	2.9 kg

* Display electronics add 0.2 lbs. (0.1 kg) to total weight.

SPECIFICATIONS - STAINLESS STEEL *continued*

Performance

Linear Range for 1/2 in. and 3/4 in.: 10:1 @ $\pm 2.0\%$ of reading
 Linear Range for 1 in.: 10:1 @ $\pm 1.5\%$ of reading
 Linear Range for 1-1/2 in. and 2 in.: 10:1 @ $\pm 1.0\%$ of reading
 Repeatability: $\pm 0.1\%$

Pressure Rating 1,500 PSIG (103 bar) Standard
 3,000 PSIG (207 bar) -HP Models

Wetted Components

Housing: 316 Stainless Steel
 Journal Bearings: Ceramic (96% Alumina)
 Shaft: Tungsten Carbide
 Rotor and Supports: PVDF
 Retaining Rings: 316 Stainless Steel

Temperature Range

Turbine only without computer: -40° to $+250^{\circ}$ F (-40° to $+121^{\circ}$ C)
 Turbine with display electronics: 0° to $+140^{\circ}$ F (-18° to $+60^{\circ}$ C)
 (Display electronics or accessory modules determine final operational temperature.)

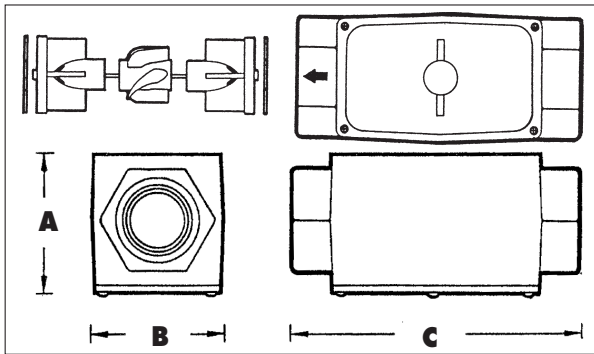

Dimensions

Models Size	FTB791 1/2 in.	FTB792 3/4 in.	FTB793 1 in.	FTB794 1-1/2 in.	FTB795 2 in.
A = Height:					
Inches	1.8 in.	2.0 in.	2.2 in.	2.8 in.	3.2 in.
Centimeters	4.6 cm	5.1 cm	5.6 cm	7.1 cm	8.2 cm
B = Width					
Inches	2.0 in.	2.0 in.	2.0 in.	2.7 in.	3.3 in.
Centimeters	5.1 cm	5.1 cm	5.1 cm	6.9 cm	8.4 cm
C = Length (Threaded)					
Inches	4.2 in.	4.3 in.	4.5 in.	5.3 in.	6.3 in.
Centimeters	10.7 cm	10.9 cm	11.4 cm	13.5 cm	16.0 cm
C = Length (Tri-Grip)					
Inches	5.0 in.	5.0 in.	5.5 in.	6.5 in.	7.0 in.
Centimeters	12.7 cm	12.7 cm	14.0 cm	16.5 cm	17.8 cm

Display electronics add 0.7 in. (1.8 cm) to height of turbine.

SPECIFICATIONS - BRASS

All data on FTB791-BRASS, FTB792-BRASS, and FTB793-BRASS determined with 1 centipoise stoddard solvent test fluid at 70° F (21° C). Data on FTB794-BRASS and FTB795-BRASS is determined with water at 70° F (21° C).

Models	FTB791- BRASS	FTB792- BRASS	FTB793- BRASS	FTB794- BRASS	FTB795- BRASS
Size	1/2 in.	3/4 in.	1 in.	1-1/2 in.	2 in.
Linear Flow Range					
Gallons/minute (GPM)	1-10	2-20	5-50	10-100	20-200
Liters/minute (LPM)	3.8-37.9	7.6-75.7	18.9-190	38-380	76-760
Maximum Flow					
Gallons/minute (GPM)	15	30	75	150	300
Liters/minute (LPM)	56.8	113.6	284	568	1,136
Maximum Pressure Drop in 10:1 Range					
PSIG	8	7.5	5	4	4
bar	0.55	0.5	0.34	0.28	0.28
Frequency Range in Linear Flow Range	45-450 Hz	37-370 Hz	45-475 Hz	35-350 Hz	33-330 Hz
Connections					
NPT Female Inlet/Outlet Size	Yes	Yes	Yes	Yes	Yes
Female Inlet/Outlet Size	1/2 in.	3/4 in.	1 in.	1-1/2 in.	2 in.
Wrench Size:					
Inch	1-1/16 in.	1-5/16 in.	1-5/8 in.	2-3/8 in.	3 in.
Millimeter	27 mm	33 mm	41 mm	60 mm	75 mm
Weight*					
Pounds	2.0 lbs.	2.3 lbs.	2.7 lbs.	6.0 lbs.	9.6 lbs.
Kilograms	0.9 kg	1.0 kg	1.2 kg	2.7 kg	4.3 kg

* Computer electronics add 0.2 lbs. (0.1 kg) to total weight.

SPECIFICATIONS - BRASS *continued*

Performance

Linear Range for 1/2 in. and 3/4 in.:	10:1 @ ±2.0% of reading
Linear Range for 1 in.:	10:1 @ ±1.5% of reading
Linear Range for 1-1/2 in. and 2 in.:	10:1 @ ±1.0% of reading
Repeatability:	±0.1%

Pressure Rating 300 PSIG (21 bar)

Wetted Components

Housing:	Brass
Journal Bearings:	Ceramic (96% Alumina)
Shaft:	Tungsten Carbide
Rotor and Supports:	PVDF
Retaining Rings:	316 Stainless Steel

Temperature Range

Turbine only without computer:	-40° to +250° F (-40° to +121° C)
Turbine with display electronics:	0° to +140° F (-18° to +60° C)

(Display electronics or accessory modules determine final operational temperature.)

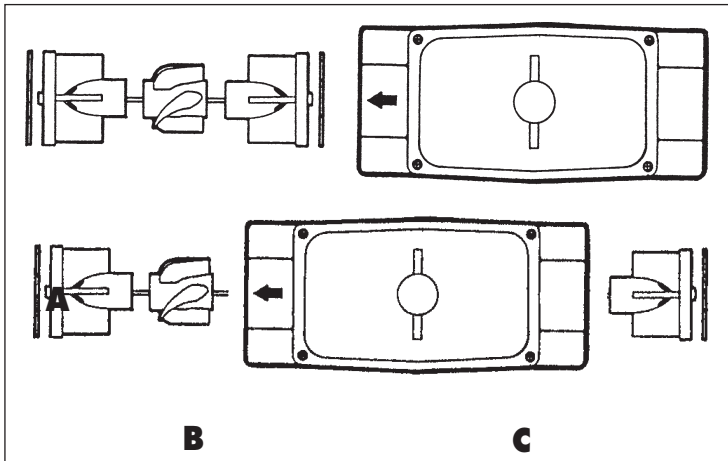

Dimensions

Models	FTB791- BRASS 1/2 in.	FTB792- BRASS 3/4 in.	FTB793- BRASS 1 in.	FTB794- BRASS 1-1/2 in.	FTB795- BRASS 2 in.
A = Height:					
Inches	1.8 in.	2.0 in.	2.2 in.	2.8 in.	3.2 in.
Centimeters	4.6 cm	5.1 cm	5.6 cm	7.1 cm	8.2 cm
B = Width					
Inches	2.0 in.	2.0 in.	2.0 in.	2.7 in.	3.3 in.
Centimeters	5.1 cm	5.1 cm	5.1 cm	6.9 cm	8.4 cm
C = Length					
Inches	4.2 in.	4.3 in.	4.5 in.	5.3 in.	6.3 in.
Centimeters	10.7 cm	10.9 cm	11.4 cm	13.5 cm	16.0 cm

Computer electronics add 0.7 in. (1.8 cm) to height of turbine.

SPECIFICATIONS *continued*

Display Specifications

Input Pulse Rate:

Minimum Pulse In:	DC
Minimum Coil Input:	10 Hz
Maximum Raw:	1,000 Hz

K-Factor:

Minimum:	.01 pulses/unit
Maximum:	999,999 pulses/unit

Field Calibration:

Minimum Time:	10 seconds
---------------	------------

Readout Totals:

Minimum Display:	0.01
Maximum Display:	999,999

Temperatures:

Operational:	0° to +140° F (-18° to +60° C)
Storage:	-40° to +158° F (-40° to +70° C)

If wider operating temperature ranges are desired, reference information on Remote Kits.

Power:

Internal Power Supply:	2 Lithium Batteries at 3 volts each
Battery Life:	5 years
Optional External Power:	7-30 VDC

Display Electronics Terminal Connections

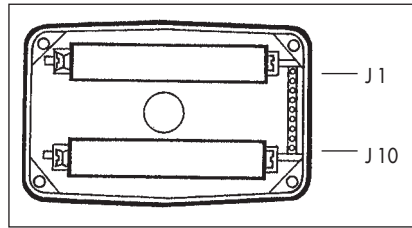

- J-1 Reset**
When connected by a jumper wire to Ground (J1-6), this has the same effect as initial power up and zeroes out all totalizers.
- J-2 Pulse Signal Output**
This supplies a high-level amplified open collector signal. Output will withstand a maximum open-circuit voltage of 60 volts DC and a maximum closed-circuit of 100 mA.
- J-3 Not Used**
- J-4 Pulse Signal Input**
Requires a sine or square wave with open-circuit voltage of 3-30 volts P-P, a maximum rise/fall rate of 0.01 V/ μ second and a maximum frequency of 750 Hz.
- J-5 Power Input**
When used with Ground (J1-6), this has reverse polarity protection, but no on-board voltage regulation. Supplied voltage must be 5.75 volts DC \pm 5%.
- J-6 Ground**
- J-7, 8, 9, 10** Programming interfaces. Not accessible to user.

NOTE: Safety approvals are void if any external connections are made to computer electronics.

SPECIFICATIONS *continued*

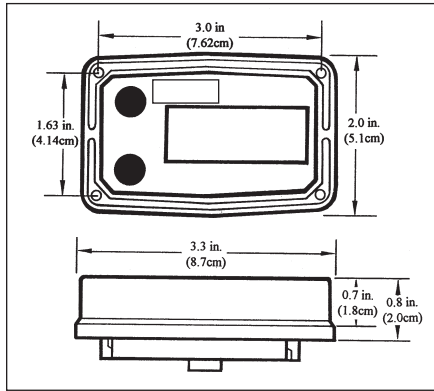

MODEL NUMBERS - STAINLESS STEEL - NPT

Model No. w/Display	Model No.* w/o Display	Range GPM (LPM)	FNPT Size
FTB791	FTB791-ND	1-10 (3.8-37.9)	1/2"
FTB792	FTB792-ND	2-20 (7.6-75.9)	3/4"
FTB793	FTB793-ND	5-50 (19-190)	1"
FTB794	FTB794-ND	10-100 (38-380)	1-1/2"
FTB795	FTB795-ND	20-200 (76-760)	2"

* Requires signal output module P/N - FLSC790-P-ND ordered separately.

† Extended low flow range and field calibration for viscosity available on - ND units w/o display.

MODEL NUMBERS - STAINLESS STEEL - TRI

Model No. w/Display	Model No.* w/o Display	Range GPM (LPM)	CLAMP Size
FTB791-TRI	FTB791-ND-TRI	1-10 (3.8-37.9)	3/4"
FTB792-TRI	FTB792-ND-TRI	2-20 (7.6-75.9)	1"
FTB793-TRI	FTB793-ND-TRI	5-50 (19-190)	1-1/2"
FTB794-TRI	FTB794-ND-TRI	10-100 (38-380)	2"
FTB795-TRI	FTB795-ND-TRI	20-200 (76-760)	2-1/2"

* Requires signal output module P/N - FLSC790-P-ND ordered separately.

† Extended low flow range and field calibration for viscosity available on - ND units w/o display.

MODEL NUMBERS - STAINLESS STEEL - HP

Model No. w/Display	Model No.* w/o Display	Range GPM (LPM)	FNPT Size
FTB791-HP	FTB791-ND-HP	1-10 (3.8-37.9)	1/2"
FTB792-HP	FTB792-ND-HP	2-20 (7.6-75.9)	3/4"
FTB793-HP	FTB793-ND-HP	5-50 (19-190)	1"
FTB794-HP	FTB794-ND-HP	10-100 (38-380)	1-1/2"
FTB795-HP	FTB795-ND-HP	20-200 (76-760)	2"

MODEL NUMBERS - STAINLESS STEEL - ISO

Model No. w/Display	Model No.* w/o Display	Range GPM (LPM)	ISO Size
FTB791-ISO	FTB791-ND-ISO	1-10 (3.8-37.9)	Rc 1/2
FTB792-ISO	FTB792-ND-ISO	2-20 (7.6-75.9)	Rc 3/4
FTB793-ISO	FTB793-ND-ISO	5-50 (19-190)	Rc 1
FTB794-ISO	FTB794-ND-ISO	10-100 (38-380)	Rc 1-1/2
FTB795-ISO	FTB795-ND-ISO	20-200 (76-760)	Rc 2

MODEL NUMBERS - BRASS

Model No. w/Display	Model No.* w/o Display	Range GPM (LPM)	FNPT Size
FTB791- BRASS	FTB791-ND- BRASS	1-10 (3.8-37.9)	1/2"
FTB792- BRASS	FTB792-ND- BRASS	2-20 (7.6-75.9)	3/4"
FTB793- BRASS	FTB793-ND- BRASS	5-50 (19-190)	1"
FTB794- BRASS	FTB794-ND- BRASS	10-100 (38-380)	1-1/2"
FTB795- BRASS	FTB795-ND- BRASS	20-200 (76-760)	2"

* Requires signal output module P/N - FLSC790-P-ND ordered separately.

† Extended low flow range and field calibration for viscosity available on - ND units w/o display.

PARTS & ACCESSORIES

Order Replacement Kits with the part numbers given here.

Part Number	Description
FTB890-ORING	O-Ring
FTB791-RK	(1/2 inch) Rotor/Support Replacement Kit
FTB792-RK	(3/4 inch) Rotor/Support Replacement Kit
FTB793-RK	(1 inch) Rotor/Support Replacement Kit
FTB794-RK	(1-1/2 inch) Rotor/Support Replacement Kit
FTB795-RK	(2 inch) Rotor/Support Replacement Kit
FTB791-RETAINING	(1/2 inch) Retaining Ring
FTB792-RETAINING	(3/4 inch) Retaining Ring
FTB793-RETAINING	(1 inch) Retaining Ring
FTB794-RETAINING	(1-1/2 inch) Retaining Ring
FTB795-RETAINING	(2 inch) Retaining Ring

Field Installable Options and Accessories

Model Number	Description
FLSC790-MA	4-20 mAdc Output Module
FLSC790-P	Pulse Output Module (open collector output)
FLSC790-P-DC	External Power Module for FLSC790-P (9-30Vdc)
FTB790-RK	Remote Display Kit Module
FTB790-RK-FM	FM Approved Remote Display Kit Module
FLSC790-BATT	Replacement Batteries
FLSC790-P-ND	Pulse Output for Models without Displays (-ND suffix)(open collector output)

Except as noted, Options and Accessories are for Display Models only and only one Module may be installed per unit. All models are supplied with 10 ft. cable. Cable may be cut or extended as required. Customer supplied pull-up resistor required, 820 ohm (min).

WARRANTY/DISCLAIMER

OMEGA ENGINEERING, INC. warrants this unit to be free of defects in materials and workmanship for a period of **13 months** from date of purchase. OMEGA's WARRANTY adds an additional one (1) month grace period to the normal **one (1) year product warranty** to cover handling and shipping time. This ensures that OMEGA's customers receive maximum coverage on each product.

If the unit malfunctions, it must be returned to the factory for evaluation. OMEGA's Customer Service Department will issue an Authorized Return (AR) number immediately upon phone or written request. Upon examination by OMEGA, if the unit is found to be defective, it will be repaired or replaced at no charge. OMEGA's WARRANTY does not apply to defects resulting from any action of the purchaser, including but not limited to mishandling, improper interfacing, operation outside of design limits, improper repair, or unauthorized modification. This WARRANTY is VOID if the unit shows evidence of having been tampered with or shows evidence of having been damaged as a result of excessive corrosion; or current, heat, moisture or vibration; improper specification; misapplication; misuse or other operating conditions outside of OMEGA's control. Components in which wear is not warranted, include but are not limited to contact points, fuses, and triacs.

OMEGA is pleased to offer suggestions on the use of its various products. However, OMEGA neither assumes responsibility for any omissions or errors nor assumes liability for any damages that result from the use of its products in accordance with information provided by OMEGA, either verbal or written. OMEGA warrants only that the parts manufactured by the company will be as specified and free of defects. OMEGA MAKES NO OTHER WARRANTIES OR REPRESENTATIONS OF ANY KIND WHATSOEVER, EXPRESSED OR IMPLIED, EXCEPT THAT OF TITLE, AND ALL IMPLIED WARRANTIES INCLUDING ANY WARRANTY OF MERCHANTABILITY AND FITNESS FOR A PARTICULAR PURPOSE ARE HEREBY DISCLAIMED. LIMITATION OF LIABILITY: The remedies of purchaser set forth herein are exclusive, and the total liability of OMEGA with respect to this order, whether based on contract, warranty, negligence, indemnification, strict liability or otherwise, shall not exceed the purchase price of the component upon which liability is based. In no event shall OMEGA be liable for consequential, incidental or special damages.

CONDITIONS: Equipment sold by OMEGA is not intended to be used, nor shall it be used: (1) as a "Basic Component" under 10 CFR 21 (NRC), used in or with any nuclear installation or activity; or (2) in medical applications or used on humans. Should any Product(s) be used in or with any nuclear installation or activity, medical application, used on humans, or misused in any way, OMEGA assumes no responsibility as set forth in our basic WARRANTY/DISCLAIMER language, and, additionally, purchaser will indemnify OMEGA and hold OMEGA harmless from any liability or damage whatsoever arising out of the use of the Product(s) in such a manner.

RETURN REQUESTS/INQUIRIES

Direct all warranty and repair requests/inquiries to the OMEGA Customer Service Department. BEFORE RETURNING ANY PRODUCT(S) TO OMEGA, PURCHASER MUST OBTAIN AN AUTHORIZED RETURN (AR) NUMBER FROM OMEGA'S CUSTOMER SERVICE DEPARTMENT (IN ORDER TO AVOID PROCESSING DELAYS). The assigned AR number should then be marked on the outside of the return package and on any correspondence.

The purchaser is responsible for shipping charges, freight, insurance and proper packaging to prevent breakage in transit.

FOR **WARRANTY** RETURNS, please have the following information available BEFORE contacting OMEGA:

1. Purchase Order number under which the product was PURCHASED,
2. Model and serial number of the product under warranty, and
3. Repair instructions and/or specific problems relative to the product.

FOR **NON-WARRANTY** REPAIRS, consult OMEGA for current repair charges. Have the following information available BEFORE contacting OMEGA:

1. Purchase Order number to cover the COST of the repair,
2. Model and serial number of the product, and
3. Repair instructions and/or specific problems relative to the product.

OMEGA's policy is to make running changes, not model changes, whenever an improvement is possible. This affords our customers the latest in technology and engineering.

OMEGA is a registered trademark of OMEGA ENGINEERING, INC.

© Copyright 2009 OMEGA ENGINEERING, INC. All rights reserved. This document may not be copied, photocopied, reproduced, translated, or reduced to any electronic medium or machine-readable form, in whole or in part, without the prior written consent of OMEGA ENGINEERING, INC.

Where Do I Find Everything I Need for Process Measurement and Control? **OMEGA...Of Course!** *Shop online at omega.comSM*

TEMPERATURE

- ☑ Thermocouple, RTD & Thermistor Probes, Connectors, Panels & Assemblies
- ☑ Wire: Thermocouple, RTD & Thermistor
- ☑ Calibrators & Ice Point References
- ☑ Recorders, Controllers & Process Monitors
- ☑ Infrared Pyrometers

PRESSURE, STRAIN AND FORCE

- ☑ Transducers & Strain Gages
- ☑ Load Cells & Pressure Gages
- ☑ Displacement Transducers
- ☑ Instrumentation & Accessories

FLOW/LEVEL

- ☑ Rotameters, Gas Mass Flowmeters & Flow Computers
- ☑ Air Velocity Indicators
- ☑ Turbine/Paddlewheel Systems
- ☑ Totalizers & Batch Controllers

pH/CONDUCTIVITY

- ☑ pH Electrodes, Testers & Accessories
- ☑ Benchtop/Laboratory Meters
- ☑ Controllers, Calibrators, Simulators & Pumps
- ☑ Industrial pH & Conductivity Equipment

DATA ACQUISITION

- ☑ Data Acquisition & Engineering Software
- ☑ Communications-Based Acquisition Systems
- ☑ Plug-in Cards for Apple, IBM & Compatibles
- ☑ Datalogging Systems
- ☑ Recorders, Printers & Plotters

HEATERS

- ☑ Heating Cable
- ☑ Cartridge & Strip Heaters
- ☑ Immersion & Band Heaters
- ☑ Flexible Heaters
- ☑ Laboratory Heaters

ENVIRONMENTAL MONITORING AND CONTROL

- ☑ Metering & Control Instrumentation
- ☑ Refractometers
- ☑ Pumps & Tubing
- ☑ Air, Soil & Water Monitors
- ☑ Industrial Water & Wastewater Treatment
- ☑ pH, Conductivity & Dissolved Oxygen Instruments