

iSERVER - ADDENDUM For iBTX-M



These changes are the result of the following product enhancement:

New case mounting design.

This addendum applies to Part 2 Hardware in your iServer Operator's Manual.



2.1 Wall Mounting

Position unit where required. Mark and drill the two #4 screw holes.

After bracket is mounted on the wall, align back of unit over the three bracket clips, once engaged, slide downward, the unit will snap in place.

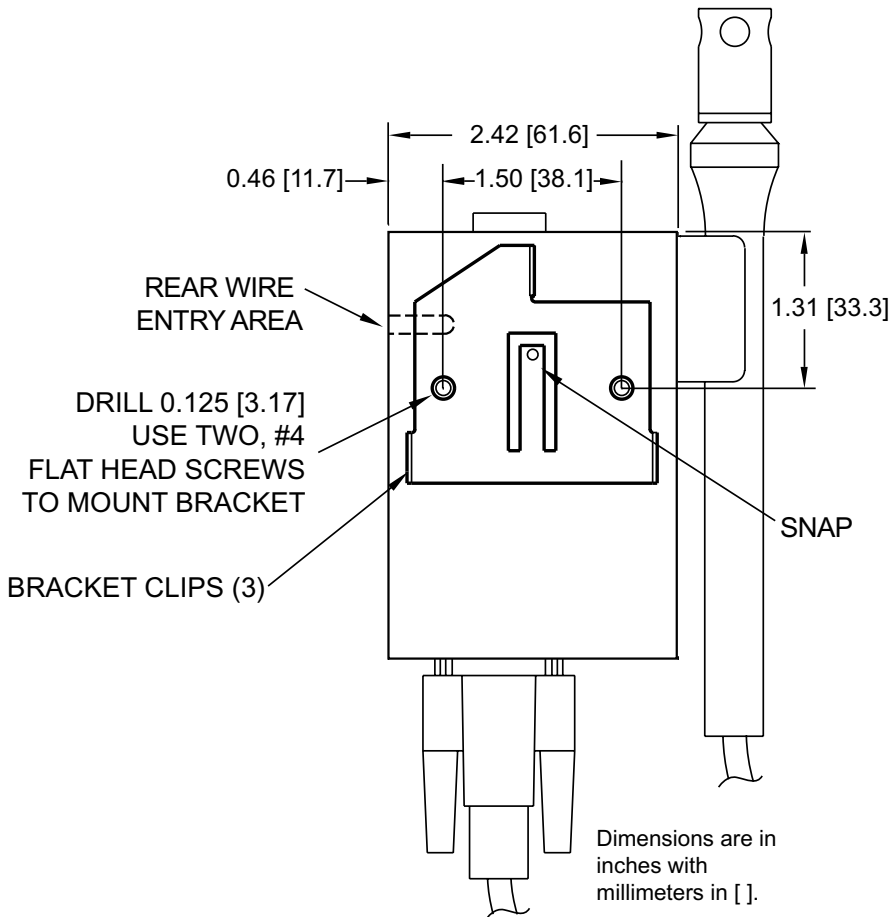

Figure 2.1 - Mounting Bracket

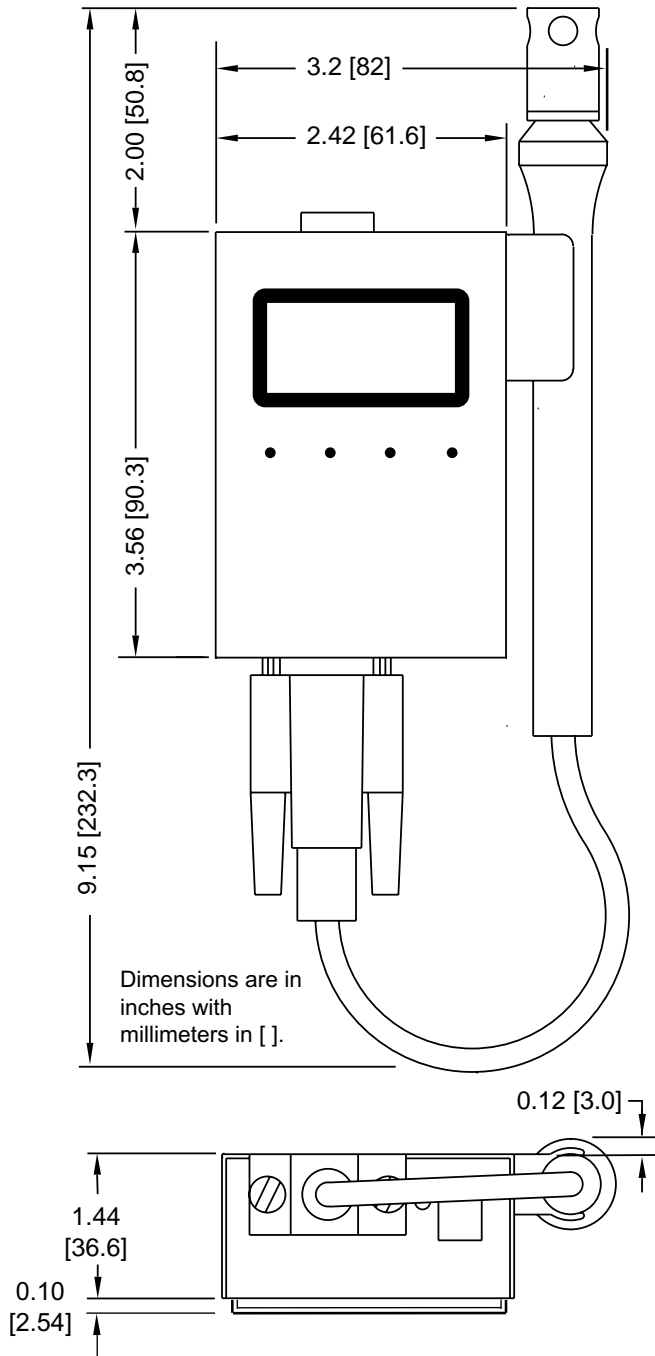

Figure 2.2 Dimensions