

1 YEAR
WARRANTY

Ω OMEGA™ User's Guide



**Shop online at
omega.com**

**e-mail: info@omega.com
For latest product manuals:
www.omegamanual.info**

ISO 9001
CERTIFIED
CORPORATE QUALITY

NORWALK, CT

ISO 9001
CERTIFIED
CORPORATE QUALITY

MANCHESTER, UK

FP7002/FP7002A Flow/Temperature Transmitter



omega.com info@omega.com

Servicing North America:

**U.S.A.
Headquarters:**

Omega Engineering, Inc.

Toll-Free: 1-800-826-6342 (USA & Canada only)

Customer Service: 1-800-622-2378 (USA & Canada only)

Engineering Service: 1-800-872-9436 (USA & Canada only)

Tel: (203) 359-1660

Fax: (203) 359-7700

e-mail: info@omega.com

For Other Locations Visit omega.com/worldwide

FP7002/FP7002A FLOW/TEMPERATURE TRANSMITTER

SECTION	PAGE
Section 1 - General Description	1
Section 2 - Installation	1
2.1 Unpacking	1
2.2 Important Considerations Before Installation	1
2.3 Flowmeter Installation	2
2.4 Electrical Connections	4
Section 3 - Maintenance	5
Section 4 - Calibration	5
4.1 Flow Calibration	5
4.2 Temperature Calibration	6
4.3 Calibration Setup	7
Section 5 - Specifications	9



Introduction/Safety

Your FP7002/FP7002A has been designed for ease of use and flexibility. It is important that you read this user's manual completely and follow all safety precautions before operating your unit.

Precautions

1. FOLLOW ALL SAFETY PRECAUTIONS AND OPERATING INSTRUCTIONS OUTLINED IN THIS MANUAL.
3. ADD ADDITIONAL SAFEGUARDS TO YOUR SYSTEM IN CRITICAL APPLICATIONS WHERE DAMAGE OR INJURY MAY RESULT FROM SENSOR FAILURE.
5. DO NOT OPERATE IN FLAMMABLE OR EXPLOSIVE ENVIRONMENTS.
6. DO NOT USE IN HUMAN MEDICAL OR NUCLEAR APPLICATIONS.
7. NEVER OPERATE WITH A POWER SOURCE OTHER THAN WHAT IS SPECIFIED IN THIS MANUAL.
8. REMOVE AND/OR DISCONNECT POWER SOURCE BEFORE ATTEMPTING INSTALLATION OR MAINTENANCE.
9. ALWAYS OPERATE YOUR UNIT WITH THE SHIELD WIRE CONNECTED TO EARTH GROUND.
10. INSTALLATION AND WIRING SHOULD BE DONE BY TRAINED PROFESSIONALS ONLY.

NOTE

There are no user serviceable parts inside your unit. Attempting to open, repair or service your unit may void your warranty.

Section 1 - General Description

The FP7002 flow /temperature transmitter is ideal for monitoring of typical industrial water flows and temperature, from hard-to-handle corrosive aqueous solutions to high purity fluids. The FP7002 uses a paddlewheel-like rotor whose motion is converted into a pulse output. This pulse output is converted to a 4 - 20 mA (or 1 - 5 Vdc) analog output by the built-in signal conditioner. A solid state temperature sensor built into the sensor body provides a separate 4 - 20 mA (or 1 - 5 Vdc) analog output directly proportional to changes in fluid temperature. These independent analog outputs can be run long distances to a panel meter, controller or computer.

A complete flow measurement system consists of the flow sensor / transmitter, the installation fitting and a readout device. The FP7002 has polypropylene, 316SS, and FKM wetted parts. The schedule 40 PVC tee fittings are supplied with a PVC locking nut, and the galvanized iron tee fittings are supplied with a brass locking nut to provide a secure metal to-metal mounting to the threaded brass insert.

Section 2 - Installation

2.1 Unpacking

Remove the Packing List and verify that you have received all equipment. If you have any questions about the shipment, please call the OMEGA Customer Service Department.

When you receive the shipment, inspect the container and equipment for any signs of damage. Note any evidence of rough handling in transit. Immediately report any damage to the shipping agent.

NOTE

The carrier will not honor any claims unless all shipping material is saved for their examination. After examining and removing contents, save packing material and carton in the event that reshipment is necessary.

2.2 Important Considerations Before Installation

CAUTION

THE FP7002 PADDLEWHEEL FLOW TRANSMITTER IS NOT EXPLOSION-PROOF, NOR IS IT INTRINSICALLY SAFE. IT IS NOT TO BE USED FOR FLAMMABLE OR HAZARDOUS LIQUIDS, NOR CAN IT BE USED IN HAZARDOUS AREAS.

The FP7002 is intended for use with water and other low viscosity liquids ONLY; it can NOT be used with oils and other viscous

materials. It can be used with non-flammable, non-hazardous liquids up to 5 centipoise viscosity, but field calibration is recommended for accurate measurements.

It is important to note that most process water contains dissolved minerals. If the flowsensor is repeatedly exposed to process water and then the line is allowed to dry, these dissolved minerals will deposit onto the FP7002 and will inhibit the low flowrate operation of the sensor. If this occurs, cleaning of the sensor is recommended.

CAUTION

WATER HAMMER AND SURGES CAN BE DAMAGING TO ANY FLOWMETER AND MUST ALWAYS BE AVOIDED.

WATER HAMMER OCCURS WHEN A LIQUID FLOW IS SUDDENLY STOPPED AS WITH QUICK CLOSING AND SOLENOID OPERATED VALVES. SURGES OCCUR WHEN FLOW IS SUDDENLY BEGUN, AS WHEN A PUMP IS TURNED ON AT FULL POWER OR A VALVE IS QUICKLY OPENED.

LIQUID SURGES ARE PARTICULARLY DAMAGING TO FLOWMETERS IF THE PIPE IS ORIGINALLY EMPTY. TO AVOID DAMAGING SURGES, FLUID LINES SHOULD REMAIN FULL (IF POSSIBLE) AND PUMPS SHOULD BE BROUGHT UP TO POWER AND VALVES OPENED SLOWLY. IN ADDITION, TO AVOID BOTH WATER HAMMER AND SURGES, A SURGE CHAMBER SHOULD BE INSTALLED.

2.3 Flowmeter Installation

The FP7002 can be mounted in vertical or horizontal pipe runs; however, the pipe must be full of liquid for proper readings. Thus, the sensor should not be mounted in vertical pipe where the liquid flows down, since the pipe may not always be full in this situation. Refer to Figures 2-1 and 2-2.

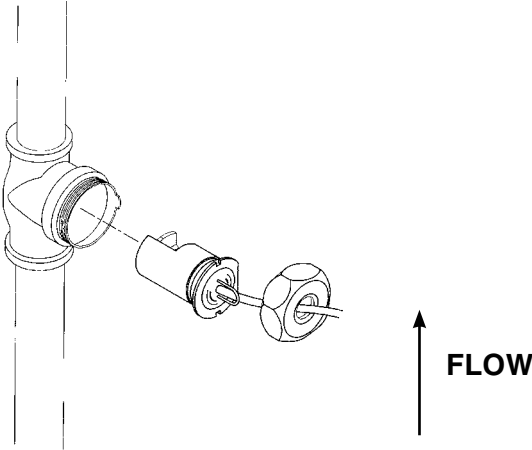

Figure 2-1. Horizontal Mounting Position

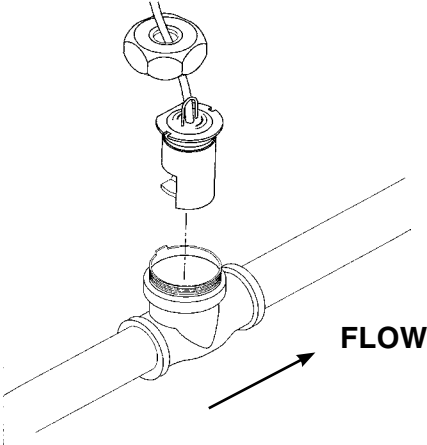

Figure 2-2. Vertical Mounting Position

The FP7002 should not be mounted at the bottom of the pipe (the 6 o'clock position) because this is where sediment in the liquid will tend to accumulate. The best mounting location is at or near the 12 o'clock position, so long as bubbles are not present in the liquid. The 3 o'clock and 9 o'clock positions are also acceptable. In an upward flowing vertical pipe, the flowsensor can be mounted anywhere around the pipe.

As with many flowmeters, the FP7002 requires a fully developed flow profile in order to provide accurate readings. To insure this, a length of straight pipe run before and after the flowmeter is required. The amount of upstream straight pipe run that is required depends upon the type of obstruction which is immediately upstream of the flowsensor. See Table 2-1 for specific requirements. Downstream of the flowsensor, in all situations, only 5 diameters of straight pipe run is required, regardless of the downstream obstruction.

Table 2-1

UPSTREAM OBSTRUCTION	STRAIGHT PIPE RUN REQUIRED UPSTREAM OF PADDLEWHEEL SENSOR
Concentric reducer	15 pipe diameters
One elbow	20 pipe diameters
2 elbows, in same plane	25 pipe diameters
2 elbows, in two planes, or one expansion	40 pipe diameters
Valves, pumps*, same plane	at least 50 pipe diameters, prefer sensor mounted upstream

*Oscillating or reciprocating pumps, which produce flow and pressure pulses in the flowstream, are not recommended for use with the FP7002 flowsensor.

NOTE

If you do not have the proper amount of straight pipe run available at your desired installation location, it is recommended to use flow straighteners to decrease the required straight run.

The paddlewheel must be aligned with the fluid flow; the installation fitting is supplied with an alignment tab which mates with a flat on the base of the paddlewheel sensor to insure proper sensor alignment. When using the PVC installation fitting, it is critical that the cap of the sensor is threaded onto the mating fitting **HAND TIGHT ONLY**; use of pipe wrenches, etc. on the plastic cap can lead to damage to the cap and/or the installation fitting.

The FP7002 has magnets installed in the rotating paddles; these magnets will tend to attract rust from the flowing fluid. Thus, it is NOT recommended to install the FP7002 in pipes which under typical conditions contain rust, such as in cast iron, black iron, carbon steel and other iron pipes (galvanized pipe has been treated to resist rust). In situations where rust can not be avoided, it is recommended to install a fine magnetic filter at least 50 pipe diameters upstream from the FP7002 and to periodically shut down the line and remove the sensor from the installation fitting for cleaning.

2.4 Electrical Connections

CAUTION

All electrical connections and wiring should be performed by suitably trained personnel only.

NOTE

To insure proper hook-up to your indicating device, the paddles of the FP7002 can be spun in the open air by blowing onto them before the sensor is installed into the installation fitting.

This is particularly important where the pipeline can not be conveniently shut down and the sensor removed after installation.

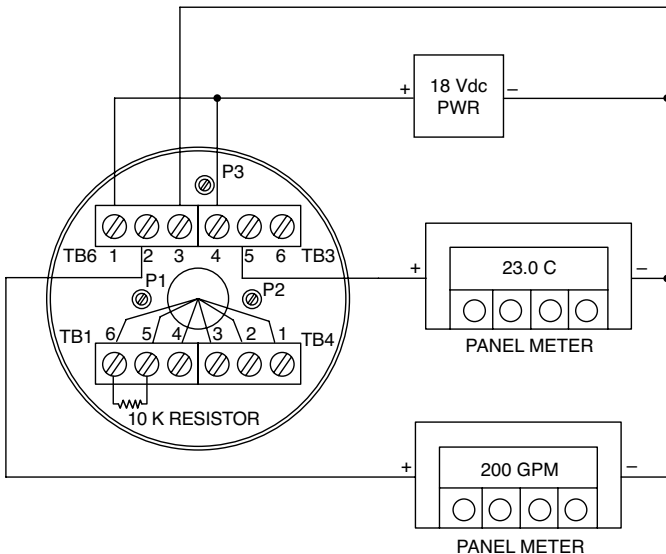

Figure 2-3. Basic Wiring Diagram

Section 3 - Maintenance

Except for intermittent removal of the sensor from the flow line for cleaning, there is no routine maintenance for the FP7002.

Section 4 - Calibration

4.1 Flow Calibration

Equipment Required:

12-18 Vdc Regulated Power Supply
 Frequency Generator/Calibrator (such as OMEGA Model: CL123)
 Multimeter (such as OMEGA Model: HHM290)
 Small jeweler's type common blade screwdriver

Calibration Procedure:

1. Unscrew and remove the protection head cover.
2. Make wiring connections to the transmitter as shown on page 7.
3. Apply power and allow the unit to warm up for 10 minutes.
4. Determine the maximum volumetric flow rate expected by the application.

For our example we will use "GPM". This will be "GPM Max"

5. From the table on page 8, determine the proper "K-Factor" for the model fitting you will be using.
6. Determine your full scale calibration frequency using this formula. This will be "F Max".

$$F \text{ Max} = \frac{K\text{-Factor} \times \text{GPM Max}}{60}$$

Example: Using a Model FP7015 Tee Fitting with a K-Factor of 29.46 and a GPM Max of 125.

$$\frac{29.46 \times 125 \text{ GPM}}{60} = 61.38 \text{ for your F Max}$$

7. Set your frequency generator for an output of 0 Hz. Adjust the zero potentiometer (P1) for a 4.00 mA output.
8. Set your frequency generator for the "F Max" you calculated above. Adjust the span potentiometer (P2) for a 20.00 mA output.
9. Set your frequency generator for one half the "F Max" you calculated above. You should have an output reading of 12.00 mA +/- 0.16 mA. If not, repeat steps 7 & 8.
10. Re-install 10 k resistor across terminals 5 and 6 and re-install white wire to terminal 5.
11. Calibration complete.

Section 4 - Calibration Cont.

4.2 Temperature Calibration

Equipment Required:

12-18 Vdc Regulated Power Supply

Type-K Thermocouple Probe (such as OMEGA Model: KTSS-HH)

Multimeter (such as OMEGA Model: HHM290)

Small potentiometer adjustment tool

Calibration Procedure:

1. Unscrew and remove the protection head cover.
2. Make wiring connections to the transmitter as shown on page 7.
3. Apply power and allow the unit to warm up for 10 minutes.
4. Place a reference temperature probe next to the body of the paddlewheel flow sensor with the unit removed from the flow line and lying on a work bench.
5. Connect the reference probe to a thermometer and allow the reading to stabilize for a few minutes. Record the reference probe reading as "Rtemp"
6. Calculate the correct current output that the transmitter should have for the ambient temperature your flow sensor and reference probe are exposed to using this formula.

$$0.16 \times Rtemp + 4 = \text{output setting}$$

Example: If your reference probe is reading 23.4°C

$$0.16 \times 23.4 + 4 = 7.74 \text{ mA}$$

7. Adjust potentiometer P3 for the correct current output you calculated above.
8. Calibration complete.

Section - Calibration Cont.

4.3 Calibration Setup

4.3.1 Flow Calibration Setup

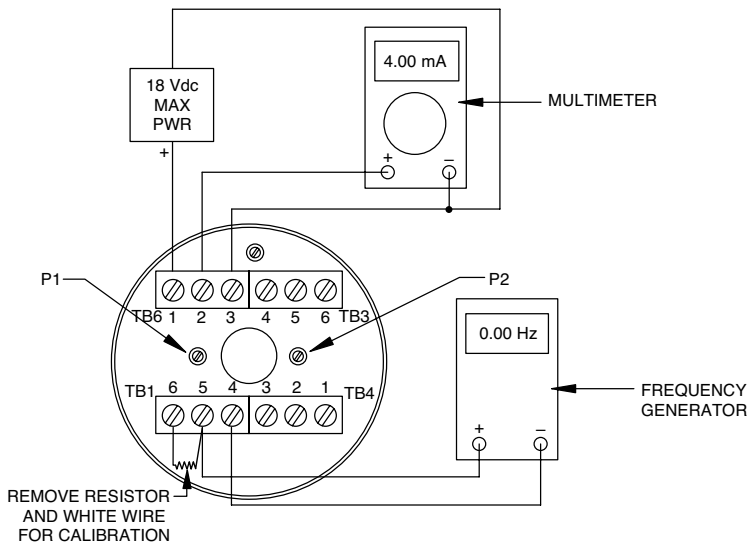

Figure 4-1. Flow Calibration Setup

4.3.2 Temperature Calibration Setup

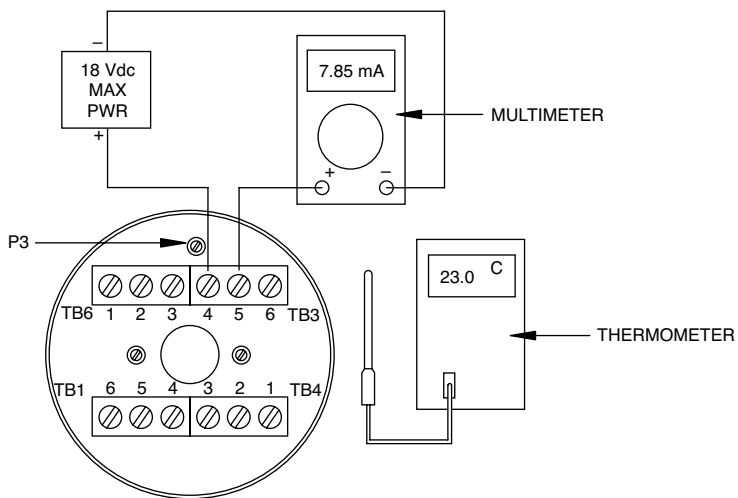

Figure 4-2. Temperature Calibration Setup

Sensor/Transmitter

FP7002 Polypropylene body/316SS shaft

INSTALLATION FITTINGS (includes locking nut)

PVC, SCHED. 40 GALVANIZED IRON (PART NUMBER)	PVC, SCHED. 40 GALVANIZED IRON (PART NUMBER)	PIPE SIZE	RANGE (GPM)
FP7007	FP7007-GI	¾"	2-30
FP7010	FP7010-GI	1"	3-50
FP7012	FP7012-GI	1¼"	5-90
FP7015	FP7015-GI	1½"	7-125
FP7020	FP7020-GI	2"	11-205
FP7025	FP7025-GI	2½"	15-285
FP7030	FP7030-GI	3"	25-460

Other fitting materials may be available. Consult the Flow Department at OMEGA.

CALIBRATION K-FACTORS

PART NUMBER	K-FACTOR	ART NUMBER	K-FACTOR
FP7007	108.78	FP7007-GI	159.85
FP7010	70.53	FP7010-GI	82.94
FP7012	41.16	FP7012-GI	48.81
FP7015	29.46	FP7015-GI	35.52
FP7020	15.52	FP7020-GI	20.62
FP7025	11.40	FP7025-GI	12.44
FP7030	6.64	FP7030-GI	7.22

VISCOSITY and SURFACE TENSION of VARIOUS LIQUIDS at 293 K

COMMON LIQUID	VISCOSITY/cP	SURFACE TENSIO/N m⁻¹
Diethyl ether	0.233	0.0728
Chloroform	0.580	0.0271
Benzene	0.652	0.0289
Carbon tetracholoride	0.969	0.0270
Water	1.002	0.0728
Ethanol	1.200	0.0228
Mercury	1.554	0.4360
Olive oil	84	-
Castor oil	986	-
Glycerol	1490	0.634
Glasses	very large	-

Section 5 - Specifications

Flow Transmitter

Accuracy:	± 2% of full scale
Repeatability:	± 1% of full scale
Power:	Regulated 9 to 18 Vdc @ 50 mA max
Input:	DC Pulse from Paddlewheel
Output:	3-Wire 4 to 20 mA or 1 to 5 Vdc
Max Loop Resistance:	Ohms = (V supply - 9 V)/0.02 A

Temperature Transmitter

Accuracy:	± 1.7°C (3°F)
Repeatability:	± 0.2°C (0.4°F)
Range:	0 to 100°C (32 to 212°F)
Power:	Regulated 9 to 18 Vdc @ 30 mA max
Output:	2-Wire 4 to 20 mA or 1 to 5 Vdc
Max Loop Resistance:	Ohms = (V supply - 9 V)/0.02 A

General

NON-WETTED MATERIALS

Transmitter Housing: NEMA Rated - Painted Cast Aluminum

WETTED MATERIALS

Sensor Body: Polypropylene body (PVDF optional), PVDF paddle, Viton O-ring, 316SS shaft. Model FP7002A includes brass locking nut. Model FP7002 includes PVC locking nut.

MAX, RECOMMENDED

FLUID VISCOSITY: 5 centipoise

FLUID TEMPERATURE/ PRESSURE RANGE:

Do not exceed the maximum ratings of your piping. Depending on the material of the fitting, the operating temperature/pressure may be limited by your piping, and not by the sensor. For all PVC tee fittings, do not exceed 150 psig @ 27°C (80°F), 100 psig @ 38°C (100°F), 60 psig @ 49°C (120°F), 30 psig @ 60°C (140°F), due to the insert in the tee. FP7000 sensor: 0° to 26°C (32° to 80°F) up to 150 psig; max pressure decreases 1.1 psig per each 1°F about 80°F for a max. temperature of 200°F at 18 psig max.

WARRANTY/DISCLAIMER

OMEGA ENGINEERING, INC. warrants this unit to be free of defects in materials and workmanship for a period of **13 months** from date of purchase. OMEGA's WARRANTY adds an additional one (1) month grace period to the normal **one (1) year product warranty** to cover handling and shipping time. This ensures that OMEGA's customers receive maximum coverage on each product.

If the unit malfunctions, it must be returned to the factory for evaluation. OMEGA's Customer Service Department will issue an Authorized Return (AR) number immediately upon phone or written request. Upon examination by OMEGA, if the unit is found to be defective, it will be repaired or replaced at no charge. OMEGA's WARRANTY does not apply to defects resulting from any action of the purchaser, including but not limited to mishandling, improper interfacing, operation outside of design limits, improper repair, or unauthorized modification. This WARRANTY is VOID if the unit shows evidence of having been tampered with or shows evidence of having been damaged as a result of excessive corrosion; or current, heat, moisture or vibration; improper specification; misapplication; misuse or other operating conditions outside of OMEGA's control. Components in which wear is not warranted, include but are not limited to contact points, fuses, and triacs.

OMEGA is pleased to offer suggestions on the use of its various products. However, OMEGA neither assumes responsibility for any omissions or errors nor assumes liability for any damages that result from the use of its products in accordance with information provided by OMEGA, either verbal or written. OMEGA warrants only that the parts manufactured by the company will be as specified and free of defects. OMEGA MAKES NO OTHER WARRANTIES OR REPRESENTATIONS OF ANY KIND WHATSOEVER, EXPRESSED OR IMPLIED, EXCEPT THAT OF TITLE, AND ALL IMPLIED WARRANTIES INCLUDING ANY WARRANTY OF MERCHANTABILITY AND FITNESS FOR A PARTICULAR PURPOSE ARE HEREBY DISCLAIMED. LIMITATION OF LIABILITY: The remedies of purchaser set forth herein are exclusive, and the total liability of OMEGA with respect to this order, whether based on contract, warranty, negligence, indemnification, strict liability or otherwise, shall not exceed the purchase price of the component upon which liability is based. In no event shall OMEGA be liable for consequential, incidental or special damages.

CONDITIONS: Equipment sold by OMEGA is not intended to be used, nor shall it be used: (1) as a "Basic Component" under 10 CFR 21 (NRC), used in or with any nuclear installation or activity; or (2) in medical applications or used on humans. Should any Product(s) be used in or with any nuclear installation or activity, medical application, used on humans, or misused in any way, OMEGA assumes no responsibility as set forth in our basic WARRANTY/DISCLAIMER language, and, additionally, purchaser will indemnify OMEGA and hold OMEGA harmless from any liability or damage whatsoever arising out of the use of the Product(s) in such a manner.

RETURN REQUESTS/INQUIRIES

Direct all warranty and repair requests/inquiries to the OMEGA Customer Service Department. BEFORE RETURNING ANY PRODUCT(S) TO OMEGA, PURCHASER MUST OBTAIN AN AUTHORIZED RETURN (AR) NUMBER FROM OMEGA'S CUSTOMER SERVICE DEPARTMENT (IN ORDER TO AVOID PROCESSING DELAYS). The assigned AR number should then be marked on the outside of the return package and on any correspondence.

The purchaser is responsible for shipping charges, freight, insurance and proper packaging to prevent breakage in transit.

FOR **WARRANTY** RETURNS, please have the following information available BEFORE contacting OMEGA:

1. Purchase Order number under which the product was PURCHASED,
2. Model and serial number of the product under warranty, and
3. Repair instructions and/or specific problems relative to the product.

FOR **NON-WARRANTY** REPAIRS, consult OMEGA for current repair charges. Have the following information available BEFORE contacting OMEGA:

1. Purchase Order number to cover the COST of the repair,
2. Model and serial number of the product, and
3. Repair instructions and/or specific problems relative to the product.

OMEGA's policy is to make running changes, not model changes, whenever an improvement is possible. This affords our customers the latest in technology and engineering.

OMEGA is a trademark of OMEGA ENGINEERING, INC.

© Copyright 2018 OMEGA ENGINEERING, INC. All rights reserved. This document may not be copied, photocopied, reproduced, translated, or reduced to any electronic medium or machine-readable form, in whole or in part, without the prior written consent of OMEGA ENGINEERING, INC.

Where Do I Find Everything I Need for Process Measurement and Control? **OMEGA...Of Course!** *Shop online at omega.com*

TEMPERATURE

- ☑ Thermocouple, RTD & Thermistor Probes, Connectors, Panels & Assemblies
- ☑ Wire: Thermocouple, RTD & Thermistor
- ☑ Calibrators & Ice Point References
- ☑ Recorders, Controllers & Process Monitors
- ☑ Infrared Pyrometers

PRESSURE, STRAIN AND FORCE

- ☑ Transducers & Strain Gages
- ☑ Load Cells & Pressure Gages
- ☑ Displacement Transducers
- ☑ Instrumentation & Accessories

FLOW/LEVEL

- ☑ Rotameters, Gas Mass Flowmeters & Flow Computers
- ☑ Air Velocity Indicators
- ☑ Turbine/Paddlewheel Systems
- ☑ Totalizers & Batch Controllers

pH/CONDUCTIVITY

- ☑ pH Electrodes, Testers & Accessories
- ☑ Benchtop/Laboratory Meters
- ☑ Controllers, Calibrators, Simulators & Pumps
- ☑ Industrial pH & Conductivity Equipment

DATA ACQUISITION

- ☑ Communications-Based Acquisition Systems
- ☑ Data Logging Systems
- ☑ Wireless Sensors, Transmitters, & Receivers
- ☑ Signal Conditioners
- ☑ Data Acquisition Software

HEATERS

- ☑ Heating Cable
- ☑ Cartridge & Strip Heaters
- ☑ Immersion & Band Heaters
- ☑ Flexible Heaters
- ☑ Laboratory Heaters

ENVIRONMENTAL MONITORING AND CONTROL

- ☑ Metering & Control Instrumentation
- ☑ Refractometers
- ☑ Pumps & Tubing
- ☑ Air, Soil & Water Monitors
- ☑ Industrial Water & Wastewater Treatment
- ☑ pH, Conductivity & Dissolved Oxygen Instruments