

**Where Do I Find Everything I Need for
Process Measurement and Control?
OMEGA...Of Course!**

TEMPERATURE

- ☑ Thermocouple, RTD & Thermistor Probes, Connectors, Panels & Assemblies
- ☑ Wire: Thermocouple, RTD & Thermistor
- ☑ Calibrators & Ice Point References
- ☑ Recorders, Controllers & Process Monitors
- ☑ Infrared Pyrometers

PRESSURE, STRAIN AND FORCE

- ☑ Transducers & Strain Gauges
- ☑ Load Cells & Pressure Gauges
- ☑ Displacement Transducers
- ☑ Instrumentation & Accessories

FLOW/LEVEL

- ☑ Rotameters, Gas Mass Flowmeters & Flow Computers
- ☑ Air Velocity Indicators
- ☑ Turbine/Paddlewheel Systems
- ☑ Totalizers & Batch Controllers

pH/CONDUCTIVITY

- ☑ pH Electrodes, Testers & Accessories
- ☑ Benchtop/Laboratory Meters
- ☑ Controllers, Calibrators, Simulators & Pumps
- ☑ Industrial pH & Conductivity Equipment

DATA ACQUISITION

- ☑ Data Acquisition & Engineering Software
- ☑ Communications-Based Acquisition Systems
- ☑ Plug-in Cards for Apple, IBM & Compatibles
- ☑ Datalogging Systems
- ☑ Recorders, Printers & Plotters

HEATERS

- ☑ Heating Cable
- ☑ Cartridge & Strip Heaters
- ☑ Immersion & Band Heaters
- ☑ Flexible Heaters
- ☑ Laboratory Heaters

**ENVIRONMENTAL
MONITORING AND CONTROL**

- ☑ Metering & Control Instrumentation
- ☑ Refractometers
- ☑ Pumps & Tubing
- ☑ Air, Soil & Water Monitors
- ☑ Industrial Water & Wastewater Treatment
- ☑ pH, Conductivity & Dissolved Oxygen Instruments

M-3772 / 0102



User's Guide



<http://www.omega.com>
e-mail: info@omega.com

**LVCN-20 Series
Ultrasonic Level Controller**

It is the policy of OMEGA to comply with all worldwide safety and EMC/CEM regulations that apply. OMEGA is constantly pursuing certification of its products to the European New Approach and Directives. OMEGA will add the CE mark to every appropriate device upon certification.

The information contained in this document is believed to be correct but OMEGA Engineering, Inc. accepts no liability for any errors it contains, and reserves the right to alter specifications without notice.

WARNING: These products are not designed for use in, and should not be used for, patient connected applications.

- USA:** ISO 9001 Certified
One Omega Drive, Box 1047
Stamford, CT 06907-0047
Tel: (203) 359-1660
e-mail: info@omega.com
Fax: (203) 359-7700
- Canada:**
Laval (Québec) HTL 5A1
976 Berger
e-mail: info@omega.com
Tel: (514) 856-6928
Fax: (514) 856-6886
- USA and Canada:**
Sales Service: 1-800-826-8934 / 1-800-TC-OMEGA™
Customer Service: 1-800-622-2278 / 1-800-622-BEST™
Engineering Service: 1-800-872-9436 / 1-800-USA-WHEAT™
TELEX: 996404 EASVLIIN; 62968934 CARLE OMEGA
- Mexico and Latin America:**
Tel: (95) 800-TC-OMEGA™
Tel: (95) 203 359-7807
Fax: (95) 203 359-7807
E-mail: espanol@omega.com
- Spain:**
En Espanol: 0800 4 ext. 2203
E-mail: espanol@omega.com
- Service Europe:**
Postbus 8034, 1180 LA Amstelveen, The Netherlands
Tel: (31) 20 6434643
Fax: (31) 20 6434643
E-mail: nl@omega.com
- Czech Republic:**
Ostavska 767, 233 01 Karvina
Tel: 42 (69) 6311899
Fax: 42 (69) 6311114
E-mail: czc@omega.com
- France:**
9 rue Denis Papin, 78190 Trappes
Tel: (33) 130 621 400
Fax: (33) 130 699 120
E-mail: france@omega.com
- Germany/Austria:**
Dahlestrasse 26, D-75392 Deckepfropfen, Germany
Tel: 49 (07056) 3017
Fax: 49 (07056) 8540
E-mail: germany@omega.com
- United Kingdom:** ISO 9002 Certified
Broughton Ashley, Leicestershire,
25 Swamington Road,
Tel: 44 (1455) 285520
Fax: 44 (1455) 283912
E-mail: uk@omega.com
Toll Free in England: 0800-488-488

Service North America:
OMEGA.net = On-Line Service
<http://www.omega.com>
Internet e-mail: info@omega.com



RETURN REQUESTS / INQUIRIES

Direct all warranty and repair requests/inquiries to the OMEGA Customer Service Department. BEFORE RETURNING ANY PRODUCTS TO OMEGA, PURCHASER MUST OBTAIN AN AUTHORIZED RETURN (AR) NUMBER FROM OMEGA'S CUSTOMER SERVICE DEPARTMENT (IN ORDER TO AVOID PROCESSING DELAYS). The assigned AR number should then be marked on the outside of the return package and on any correspondence. The purchaser is responsible for shipping charges, freight, insurance and proper packaging to prevent breakage in transit.

FOR NON-WARRANTY REPAIRS, consult OMEGA for current repair charges. Have the following information available BEFORE contacting OMEGA:

1. P.O. number under which the product was PURCHASED.
2. Model and serial number of the product under warranty, and
3. Repair instructions and/or specific problems relative to the product.

OMEGA's policy is to make repairs, whenever an improvement is possible. Problems relative to the product, model and serial number of product, and repair instructions and/or specific problems relative to the product.

OMEGA is a registered trademark of OMEGA ENGINEERING, INC.
This article or its contents are the basis in technology and engineering.
© Copyright 1996 OMEGA ENGINEERING, INC. All rights reserved. This document may not be copied, photocopied, reproduced, translated, or reduced to any electronic medium or machine-readable form, in whole or in part, without prior written consent of OMEGA ENGINEERING, INC.

WARRANTY/DISCLAIMER

OMEGA ENGINEERING, INC. warrants this unit to be free of defects in materials and workmanship for a period of 13 months from date of purchase. OMEGA Warranty adds an additional one (1) month grace period to the normal one (1) year product warranty to cover handling and shipping time. This ensures that OMEGA's customers receive maximum coverage on each product.

If the unit should malfunction, it must be returned to the factory for evaluation. OMEGA's Customer Service Department will issue an Authorized Return (AR) number immediately upon phone or written request. Upon examination by OMEGA, if the unit is found to be defective it will be repaired or replaced at no charge. OMEGA's Warranty does not apply to defects resulting from any action of the purchaser, including but not limited to mishandling, improper interfacing, operation outside of design limits, improper repair or unauthorized modification. This WARRANTY IS VOID if the unit shows evidence of having been tampered with or shows evidence of being damaged as a result of excessive corrosion or current, heat, moisture or vibration; improper specification; misapplication; misuse or other operating condition outside of OMEGA's control. Components which wear are not warranted, including but not limited to contact points, fuses, and tracks.

OMEGA is pleased to offer suggestions on the use of its various products; however, OMEGA neither assumes responsibility for any omissions or errors nor assumes liability for any damages that result from the use of its products in accordance with information provided by OMEGA, either verbal or written. OMEGA warrants only that the parts manufactured by it will be as specified and free of defects. OMEGA MAKES NO OTHER WARRANTIES OR REPRESENTATIONS OF ANY KIND WHATSOEVER. EXCEPT THAT OF TITLE, AND ALL IMPLIED WARRANTIES INCLUDING ANY WARRANTY OF MERCHANTABILITY AND FITNESS FOR A PARTICULAR PURPOSE ARE HEREBY DISCLAIMED. LIMITATION OF LIABILITY: The remedies of purchaser set forth herein are exclusive and the purchaser's sole remedy. OMEGA shall not be liable for consequential, incidental or special damages.

CONDITIONS: Equipment sold by OMEGA is not intended to be used, nor shall it be used: (1) as a "Basic Component" or used on humans; (2) in or with any nuclear installation or activity; or (3) in medical applications. OMEGA assumes no responsibility in any way OMEGA assumes no responsibility as set forth in our basic WARRANTY/DISCLAIMER. OMEGA and its subsidiaries, including OMEGA Engineering, Inc. and its subsidiaries, shall not exceed the purchase price of the component upon which liability is based. In no event shall OMEGA be liable for consequential, incidental or special damages.

OMEGA warrants harmless from any liability or damage whatsoever arising out of the use of the Product(s) in any application, medical application, used on humans, or misused in any way OMEGA assumes no responsibility as set forth in our basic WARRANTY/DISCLAIMER. OMEGA and its subsidiaries, including OMEGA Engineering, Inc. and its subsidiaries, shall not exceed the purchase price of the component upon which liability is based. In no event shall OMEGA be liable for consequential, incidental or special damages.

SPECIFICATIONS

Step One

Range:	6" to 12 feet (15.2 cm to 3.7 m)
Accuracy:	± 0.25% of span (air)
Resolution:	0.125" (3 mm)
Frequency:	50 kHz
Pulse rate:	3 per second
Beam width:	8° conical
Blocking distance:	6" (15.2 cm) minimum
LED Indication:	Power, relay & fail-safety
Fail-safety:	Power and echo fail-safe
Supply voltage:	LVCN-20-AC: 120 VAC LVCN-20-DC: 18-30 VDC
Set points:	2 per relay
Adjustments:	Potentiometer
Relay types:	(2) Latched, SPDT
Relay rating:	LVCN-20-AC: 250 VAC, 10A, 1/2 hp. LVCN-20-DC: 250 VAC, 10A, 1/4 hp.
Relay mode:	Selectable NO or NC
Relay latch:	ON or OFF
Hysteresis:	Adjustable over range
Temperature rating:	F: -40° to 140° C: -40° to 60°
Temp. compensation:	Automatic over entire range
Pressure rating:	30 psi (2 bar) @ 25 (C., derated @ 1.667 psi (.113 bar) per (C. above 25 (C.
Enclosure rating:	NEMA 4X (IP65)
Enclosure material:	Polypropylene, U.L. 94VO
Transducer material:	PVDF
Mounting conn.:	2" NPT (2" G)
Mounting gasket:	Viton (2" G) metric only
Conduit connection:	1/2" NPT
CE compliance:	EN 50082-2 immunity (LVCN-20-DC only) EN 55011 emission (LVCN-20-DC only)

About Ultrasonic Technology:

An ultrasonic sound wave is pulsed three times per second from the base of the transducer. The sound wave reflects against the process medium below and returns to the transducer. The microprocessor based electronics measures the time of flight between the sound generation and receipt, and translates this figure into the distance between the transmitter and process medium below.

Faceplate:

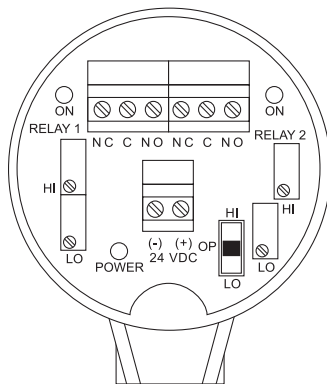

Model Chart:

Model	Power	Relay	Mounting
LVCN-21	120 VAC	250 VAC, 10A, 1/2 Hp.	2" NPT
LVCN-21-DC	18-30 VDC	250 VAC, 10A, 1/4 Hp.	2" NPT
LVCN-22	120 VAC	250 VAC, 10A, 1/2 Hp.	2" G
LVCN-22-DC	18-30 VDC	250 VAC, 10A, 1/4 Hp.	2" G

Dimensions:

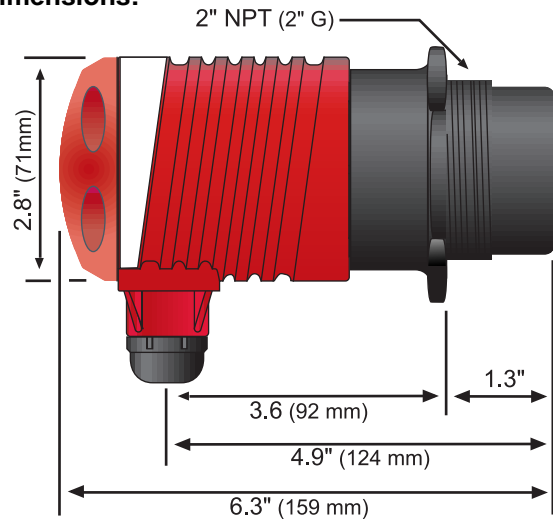

Beam Cone Radius:

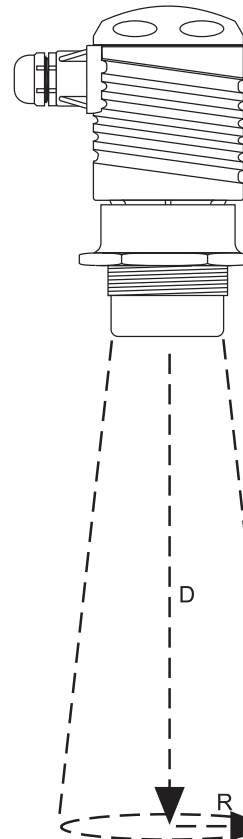

Range Feet	Radius Inches	Radius cm
1	1.2	3.1
2	2.1	5.2
3	2.9	7.3
4	3.7	9.5
5	4.9	11.6
6	5.4	13.7
7	6.2	15.9
8	7.1	18.0
9	7.9	20.1
10	8.8	22.3
11	9.6	24.4
12	10.4	26.5

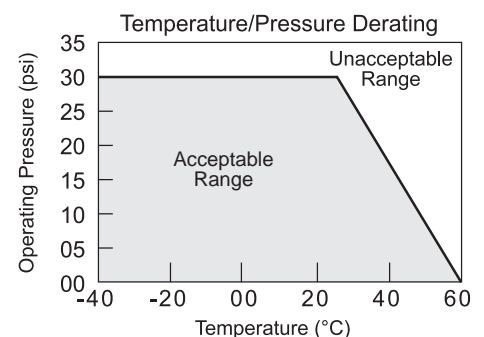

SAFETY PRECAUTIONS

Step Two

⚠ About this Manual:

PLEASE READ THE ENTIRE MANUAL PRIOR TO INSTALLING OR USING THIS PRODUCT. This manual includes information on the Bulk Tank Ultrasonic Relay Controller from OMEGA: LVCN-21-__ and LVCN-22-__. Please refer to the part number located on the sensor label to verify the exact model which you have purchased.

⚠ User's Responsibility for Safety:

OMEGA has a wide range of liquid level sensors and technologies. While each of these sensors is designed to operate in a wide variety of applications, it is the user's responsibility to select a sensor model that is appropriate for the application, install it properly, perform tests of the installed system, and maintain all components. The failure to do so could result in property damage or serious injury.

⚠ Proper Installation and Handling:

Because this is an electrically operated device, only properly-trained staff should install and/or repair this product. Use a proper sealant with all installations. Note: Always install the 2" Viton gasket with the LVCN-22-__. The G threaded version of the controller will not seal unless the gasket is installed properly. Never over-tighten the transmitter within the fitting. Always check for leaks prior to system start-up.

⚠ Wiring and Electrical:

A supply voltage of 120 VAC is used to power the LVCN-20 series controller. The system should never exceed a maximum of 120 volts AC. The supply voltage used to power the LVCN-20-DC series controller should never exceed a maximum of 30 volts DC. Electrical wiring of the sensor should be performed in accordance with all applicable national, state, and local codes.

⚠ Material Compatibility:

The LVCN-20 series enclosure is made of Polypropylene (PP). The transducer is made of Polyvinylidene Fluoride (PVDF). Make sure that the model which you have selected is chemically compatible with the application liquids it will contact.

⚠ Enclosure:

While the transmitter housing is liquid-resistant when installed properly, it is not designed to be immersed. It should be mounted in such a way that the enclosure and diaphragm do not come into contact with fluid.

⚠ Make a Fail-Safe System:

Design a fail-safe system that accommodates the possibility of transmitter or power failure. In critical applications, OMEGA recommends the use of redundant backup systems and alarms in addition to the primary system.

⚠ Flammable, Explosive and Hazardous Applications:

The LVCN-20 series controller systems should not be used within flammable or explosive applications.

⚠ Warning ⚠

Always install the 2" Viton gasket with all versions of the LVCN-22-__. The G threaded version of the Controller will not seal unless the gasket is installed properly.

GUIDE TO CONTROLS

Step Three

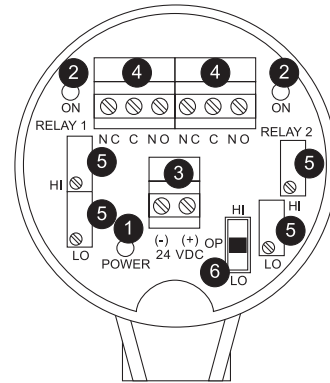

- 1. Power indicator:** This green LED lights when DC power is ON. LED will also flash when a lost echo condition occurs.
- 2. Relay indicators:** These red LED's will light whenever the transmitter energizes the relay, in response to the proper condition with the set points.
- 3. AC Power terminals (LVCN-21 & LVCN-22 series only):** Connection of 120 VAC power to the controller. Polarity (hot and neutral) does not matter.
DC Power terminals (LVCN-21-DC & LVCN-22-DC series only): Connection of 18 to 30 VDC power to the controller. Please observe the Polarity (positive and negative) of the terminal.
- 4. Relay terminals (NC, C, NO):** Connect the device you wish to control (pump, valve, alarm etc.) to these terminals: supply to the COM terminal, and the device to the NO or NC terminal as required. The switched device should be a noninductive load of not more than 10 amps; for reactive loads the current must be derated or protection circuits used. When the red LED is ON and the relay is in the energized state, the NO terminal will be closed and the NC terminal will be open.
- 5. Relay Potentiometer:** Adjusts the switching positions for each relay with its own independent Hi and Lo adjustment.
- 6. Selector Switch:** Allows for independent adjustment of the Hi or Lo setting.

WIRING

Step Four

Electrical wiring of the sensor should be performed in accordance with all applicable national, state, and local codes.

Wiring AC Power Controller (LVCN-20 series only):

Polarity does not matter for the LVCN-20 series. Do not exceed the 120 VAC power rating. The 2 relays can be connected to pumps, valves, alarms, PLC's, etc. as long as they do not exceed the 10A, 250 VAC, 1/2 Hp rating. Below illustrates using the same 120 VAC power supplying the LVCN-20 series to control two independent pumps directly.

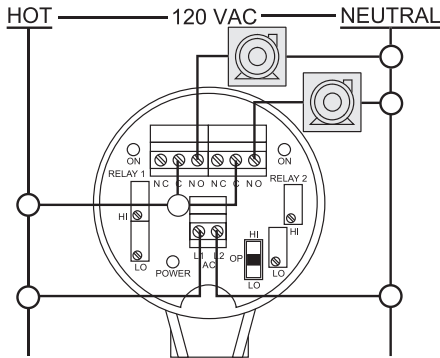

Wiring DC Power Controller (LVCN-20-DC series only):

Please observe polarity for the LVCN-20-DC series. The 2 relays can be connected to pumps, valves, alarms, PLC's, etc. as long as they do not exceed the 10A, 250 VAC, 1/4 Hp rating. Below illustrates using the same VDC power supplying the LVCN-20-DC series to control a high level and low level alarm directly. This device can be wired either Normally Open (NO) or Normally Closed (NC).

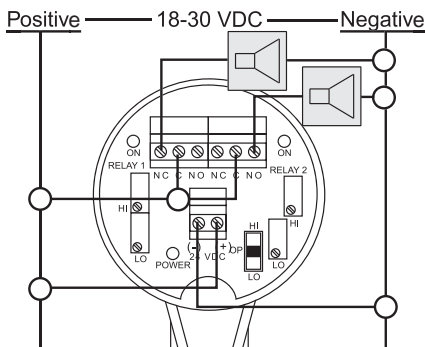

Wiring to the Relays:

The 2 relays are isolated from the power required to operate the LVCN-20 series. The relays can be used to control a device on a separate power system. The illustration below demonstrates the LVCN-21 controlling two alarms powered from a different power supply. All relay ratings will still apply.

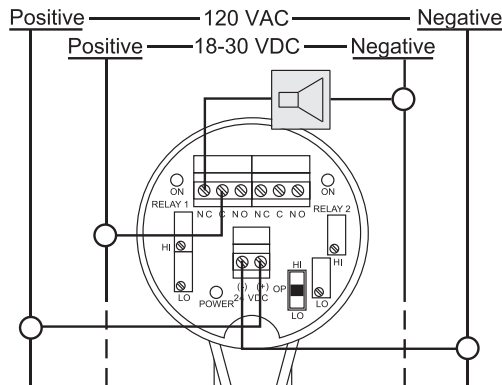

INSTALLATION

Step Five

OMEGA's LVCN-20 series controller may be installed through the top wall of a tank. Installation requires a 2" NPT (G) fitting or blind flange.

1. Install the appropriate 2" fitting in the top wall of the tank. Prior to installation, make sure that the fitting has been installed properly and checked for leaks. Use a proper sealant at the time of installation to ensure a liquid-tight seal. Secondly, make sure that the fittings threads are not damaged or worn.
2. Insert the controller into the fitting and tighten to hand tight.
3. Always check for leaks prior to system start-up. To ensure proper installation, a complete leak test and simulation of actual process conditions should be performed.

Fitting Installation

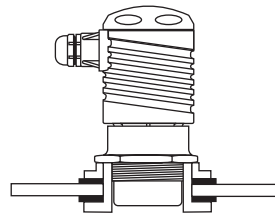

Flange Installation

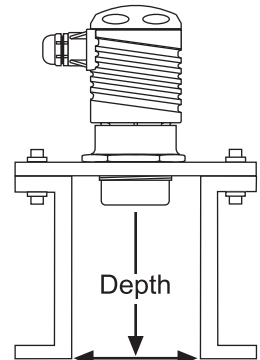

Flange Chart

Flange Inner Diameter Inch (cm)	Flange Depth Inch (cm)
3 (7.6)	3 (7.6)
4 (10.2)	7 (17.8)
5 (12.7)	11 (27.9)
6 (15.2)	15 (38.1)
7 (17.8)	19 (48.3)
8 (20.3)	26 (66.0)

Observe the Flange Chart to the left to determine the maximum depth for a flange installation.

Warning

Do not install the LVCN-20 series in pressurized applications above 30 psi.

Always install the 2" Viton gasket with all versions of the LVCN-22-__. The G threaded version of the LVCN-22-__ will not seal unless the gasket is installed properly and checked for leaks.

Use a proper sealant at the time of installation to ensure a liquid-tight seal. Secondly, make sure that the fittings threads are not damaged or worn.

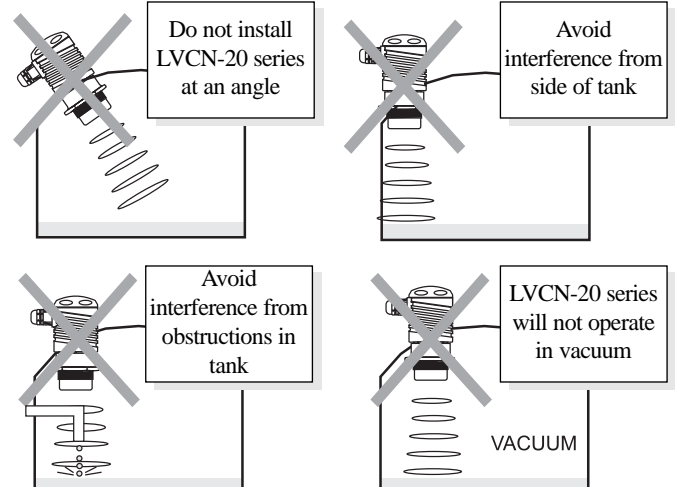

CALIBRATION

Step Six

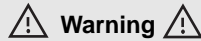

Warning

A supply voltage of 120 VAC is used to power the LVCN-20 series controller. A supply voltage of 18-30 VDC is used to power the LVCN-20-DC series controller. If making adjustments during powered operation, use extreme caution and use only insulated tools. Also, calibrate all models of the LVCN-20 series to a static liquid level or stationary object. Wiring should be preformed by qualified personnel in accordance with all applicable national, state and local electrical codes.

Power LED Indication

The LVCN-20 series features a single Green LED which indicates power and fail-safe conditions. During normal operation, the LED will be ON continuously to indicate that the controller has power and a strong echo signal return strength.

Should the LED begin to FLASH, this indicates that the LVCN-20 series has lost the acoustic signal and has gone into a fail-safe condition. During the lost echo condition, both relays will energize indicating a full tank condition. Once re-acquired, the LED will turn back ON continuously and the relays will return to their proper state. Note: during a fail-safe condition, both relays will energize. Design your system such that an energized relay state is a fail-safe condition.

Relay LED Indication

The LVCN-20 series features dual Red LED's which indicate relay status. When the LED is On, the corresponding relay is energized. When the LED is Off, the corresponding relay is de-energized.

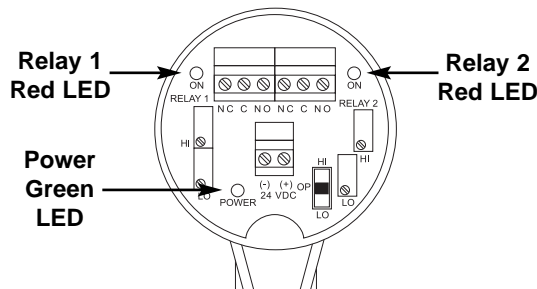

Relay LED Indication II

The relay's in the LVCN-20 series will energize when the liquid level is above both Hi and Lo points. The relay will de-energize when the level falls below both the Hi and Lo points.

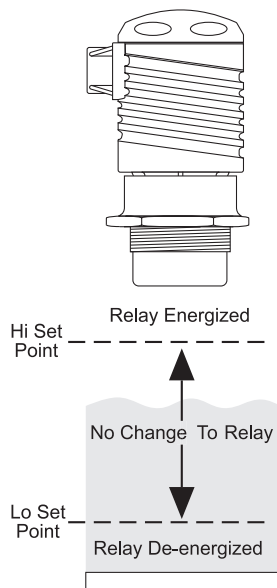

CALIBRATION

Step Seven

Note: If making adjustments during powered operation, go slow, use extreme caution and use only insulated tools.

Note: A dry calibration is possible when using a solid target. Position the LVCN-20 series in a secure location at the exact distances required.

Low Level Alarm

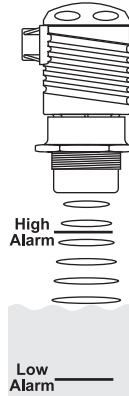

The goal is to make sure that the liquid level does not fall below a certain point. If it does, an alarm is supposed to sound, alerting the operator of a low level condition.

To do this, connect the alarm to the NC side of the relay. Connect the source of power to the Com terminal of the relay.

In this application, the switch point is normally wet. In this condition, the relay will be energized so the alarm will not sound: i.e., the Red relay LED will be On. If the fluid level falls below the low switch point, the relay de-energizes, which closes the alarm circuit and the alarm sounds.

High Level Alarm

In the same manor, this system can be used to sound an alarm when fluid reaches a high level, with just a change in the location of the switch point and the reversing of the relay.

The alarm is now connected to the NO side of the relay.

The sensor is normally dry. In this condition, the relay will be de-energized so the alarm does not sound: i.e., the Red relay LED should be Off. If the fluid level rises to the high sensor point, the sensor goes on, the relay energizes, and the alarm sounds.

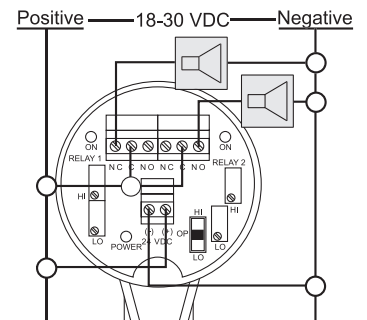

Note: Low level alarm is wired NC and the high level alarm is wired NO.

Single Point Relay

Each relay can be used as a high or low level alarm. The instructions below can be used for either function.

1. Apply appropriate power.
2. Turn the Hi and Lo Potentiometer for the relay fully clockwise (about 18 turns).
3. Set the input level to its set point.
4. Flip selector switch to Hi.
5. Adjust Hi potentiometer counter-clockwise until the LED for that relay just turns ON.
6. Turn Lo potentiometer for the relay fully counter-clockwise (about 18 turns).
7. Flip selector switch to Lo.
8. Adjust Lo potentiometer clockwise until the LED for that relay turns OFF.
9. Adjust Lo potentiometer counter-clockwise 1/4 turn, LED will turn ON.
10. Repeat steps 3 to 9 for the other relay.
11. Flip selector switch to OP.

Note: to protect the loads, the relay set points should be adjusted before the loads are connected.

Note: calibrate the LVCN-20 series to a static liquid level or stationary object.

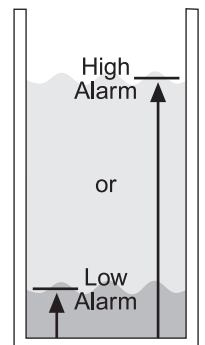

CALIBRATION

Step Eight

Note: If making adjustments during powered operation, go slow, use extreme caution and use only insulated tools.

Note: A dry calibration is possible when using a solid target. Position the LVCN-20 series in a secure location at the exact distances required.

Automatic Fill:

This system consists of a tank with a pump that is controlled by the LVCN-20 series. We connect the pump to the NC side of the relay. When the relay is de-energized, the pump will turn On and fill the tank. When the relay is energized, the pump will turn Off and stop filling the tank.

NOTE: If the pump motor load exceeds the rating of the controller's relay, a stepper relay of higher capacity must be used as part of the system design.

Automatic Empty:

Note that a similar system logic can be used for an automatic empty operation simply by controlling a pump that pumps fluid out of the tank instead of into it. However, note that the pump will now be connected to the NO side of the relay. When the relay is energized, the pump will turn On and empty the tank. When the relay is de-energized, the pump will turn Off and stop emptying the tank.

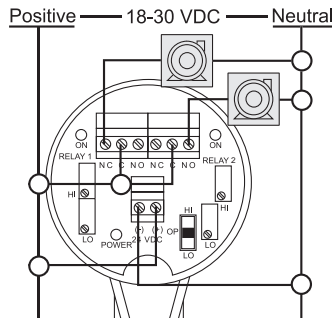

Note: Auto fill pumps are wired NC and auto empty pumps are wired NO.

Latching Relay

1. Apply appropriate Power.
2. Turn the Hi and Lo Potentiometer for the relay fully counter-clockwise (about 18 turns).
3. Set the input level to its low set point.
4. Flip selector switch to Lo.
5. Adjust Lo potentiometer clockwise until the LED for that relay just turns OFF.
6. Turn Hi potentiometer for the relay fully clockwise (about 18 turns)
7. Flip selector switch to Hi.
8. Set input level to its highest point.
9. Adjust Hi potentiometer counter-clockwise until the LED for that relay turns ON.
10. Repeat steps 3 to 9 for the other relay.
11. Flip selector switch to OP.

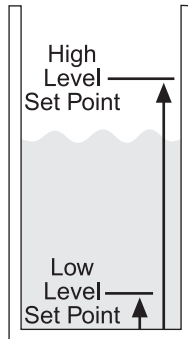

Note: to protect the loads, the relays should be adjusted before the loads are connected.

Note: calibrate the LVCN-20 series to a static liquid level or stationary object.

MAINTENANCE

Step Nine

General:

The LVCN-20 series controller itself requires no periodic maintenance except cleaning as required. It is the responsibility of the user to determine the appropriate maintenance schedule, based on the specific characteristics of the application liquids.

Cleaning Procedure:

1. **Power:** Make Sure that all power to the transmitter, controller and/or power supply is completely disconnected.
2. **Sensor Removal:** In all through-wall installations, make sure that the tank is drained well below the sensor prior to removal. Carefully, remove the sensor from the installation.
3. **Cleaning the Sensor:** Use a soft bristle brush and mild detergent, carefully wash the transducer of the LVCN-20 series. Do not use a harsh abrasive such as steel wool or sandpaper, which might damage the surface of the transmitter. Do not use incompatible solvents which may damage the PVDF transducer or the transmitters PP body.
4. **Sensor Installation:** Follow the appropriate steps of installation as outlined in the installation section of this manual.

Controller Logic

For all controllers, please use the following guide to understand the operation of the LVCN-20 series.

1. **Power LED:** Make sure the Green power LED is On when power is supplied to the controller.
2. **Relay LED(s):** The relay(s) LED(s) on the LVCN-20 series will be energized when the level is above the Hi point and de-energized when the level is below the Lo point. When the level is between the Hi and Lo points, the relay will no change its state.

Relay Logic:

The relay can either be an independent relay (high or low level alarm) or can be a latching relay (automatic fill or empty).

