

CE

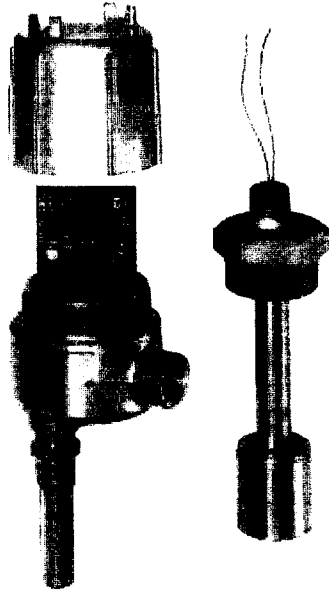

User's Guide



omega.com™
ΩMEGA®

www.omega.com

e-mail: info@omega.com

LVU-950 SERIES **Loop Power Ultrasonic Transmitter**



OMEGAnet® On-Line Service
www.omega.com

Internet e-mail
info@omega.com

Servicing North America:

USA:
ISO 9001 Certified One Omega Drive, P.O. Box 4047
Stamford CT 06907-0047
TEL: (203) 359-1660 FAX: (203) 359-7700
e-mail: info@omega.com

Canada:
976 Berger
Laval (Quebec) H7L 5A1
TEL: (514) 856-6928 FAX: (514) 856-6886
e-mail: info@omega.ca

For immediate technical or application assistance:

USA and Canada: Sales Service: 1-800-826-6342 / 1-800-TC-OMEGA®
Customer Service: 1-800-622-2378 / 1-800-622-BEST®
Engineering Service: 1-800-872-9436 / 1-800-USA-WHEN®
TELEX: 996404 EASYLINK 62968934 CABLE: OMEGA

Mexico: TEL: (001) 800-826-6342 FAX: (001) 203-359-7807
En Español: (001) 203-359-7803 e-mail: espanol@omega.com
info@omega.com.mx

Servicing Europe:

Benelux: Postbus 8034, 1180 LA Amstelveen, The Netherlands
TEL: +31 (0)20 6418405 FAX: +31 (0)20 6434643
Toll Free in Benelux: 0800 0993344
e-mail: nl@omega.com

Czech Republic: Rudf armády 1868, 733 01 Karviná 8
TEL: +420 (0)69 6311899 FAX: +420 (0)69 6311114
Toll Free: 0800-1-66342 e-mail: czech@omega.com

France: 9, rue Denis Papin, 78190 Trappes
TEL: +33 (0)130 621 400 FAX: +33 (0)130 699 120
Toll Free in France: 0800-4-06342
e-mail: france@omega.com

Germany/Austria: Daimlerstrasse 26, D-75392 Deckenpfronn, Germany
TEL: +49 (0)7056 3017 FAX: +49 (0)7056 8540
Toll Free in Germany: 0800 TC-OMEGA™
e-mail: germany@omega.com

United Kingdom: One Omega Drive, River Bend Technology Centre
ISO 9002 Certified Northbank, Irlam, Manchester
M44 5EX United Kingdom
TEL: +44 (0)161 777 6611 FAX: +44 (0)161 777 6622
Toll Free in United Kingdom: 0800-488-488
e-mail: sales@omega.co.uk

It is the policy of OMEGA to comply with all worldwide safety and EMC/EMI regulations that apply. OMEGA is constantly pursuing certification of its products to the European New Approach Directives. OMEGA will add the CE mark to every appropriate device upon certification.

The information contained in this document is believed to be correct, but OMEGA Engineering, Inc. accepts no liability for any errors it contains, and reserves the right to alter specifications without notice.

WARNING: These products are not designed for use in, and should not be used for, patient-connected applications.

DESCRIPTION

GENERAL DESCRIPTION

The LVU-950 Series Liquid Level systems are state-of-the-art level measurement instruments. Based on the latest ultrasonic technology, the LVU-950 provides an efficient, reliable and cost effective means of level control.

The LVU-950 consists of two major components, a non-contacting ultrasonic sensor and a compact, integral electronic control.

The LVU-950 sensor is available in a variety of sizes and materials to suit virtually any application. Standard mounting configurations include 3/4" and 2" NPT fittings. Flange mounting is also available to meet user specifications. Sensor material construction includes 316SS, Kynar or Teflon[®].

PRINCIPLE OF OPERATION

In operation, the electronics generate an electronic signal which is converted by the sensor (mounted on the top of the vessel) to a burst of ultrasonic pulses. These pulses are transmitted through the air toward the liquid surface. As the pulses reach the liquid surface, they are reflected back to the sensor. Those received echoes are converted back to an electronic signal which is then sent to the microprocessor. The microprocessor uses the return signals to calculate the time it takes for the pulses to travel to the liquid surface and back. This "Time of Flight" is directly proportional to the distance of the liquid surface from the sensor. The microprocessor then compares these calculated values with user programmed system parameters to provide the required control outputs.

INSTALLATION

CONTROL UNIT INSTALLATION

1. Open the control unit enclosure and remove the printed circuit board.
2. Replace printed circuit board and route power and control wiring to the enclosure. Observe all applicable local electrical codes and wiring procedures.
3. Connect power and control wiring to the control unit as shown in Wiring Diagram (see Figure 1).
4. Be sure that all wiring is carefully dressed to prevent pinching between the housing and the cover.

SENSOR INSTALLATION

The sensor is mounted on the top of the vessel with the sensor facing downward. A clear path, free of any obstructions must be provided between the sensor and the liquid surface. Due to the narrow sensor beam pattern vertical axis positioning of the sensor is important. The sensor must be installed perpendicular to the liquid surface.

1. For sensor provided with an NPT threaded fitting, drill a suitable hole in the vessel top and tap for the correct NPT thread. In thin walled vessels, or vessels constructed of material not suitable for tapping, weld or braze a bushing to accept the sensor.
2. Screw the sensor into the threaded fitting being careful not to cross thread the sensor. When possible, the use of a pipe compound or sealing tape is recommended.
AVOID OVER TIGHTENING!
3. For flange mounted sensors, simply bolt the sensor / flange assembly to the proper mating flange connection.
4. Route the sensor cable to the electronic control unit and connect per the Wiring Diagram (see Figure 1). **IF ROUTING THE SENSOR CABLE THROUGH CONDUIT, A DEDICATED CONDUIT SHOULD BE UTILIZED. AVOID ROUTING THE SENSOR CABLE IN CLOSE PROXIMITY TO ANY SOURCE OF ALTERNATING CURRENT OR RFI.**

CAUTION: DO NOT ATTEMPT TO REMOVE A THREADED SENSOR FROM THE VESSEL WITH THE CABLE ATTACHED TO THE CONTROL UNIT, OTHERWISE IT MAY DAMAGE THE CABLE.

WIRING

Note: All wiring between the power supply and the transmitter should be accomplished with 18 AWG to 22 AWG shielded twisted pair. The connection is made at the terminal strip within the transmitter enclosure. Before you connect the power line to the transmitter, be sure that the voltage identification on the nameplate matches the power supply. DO NOT attempt to operate this unit at voltages other than as identified or it will damage the unit. Refer to Wiring Diagram (Figure 1).

CAUTION: UNITS ARE DESIGNED TO OPERATE ON VDC POWER ONLY. APPLICATION OF 120 VAC WILL DESTROY THE INSTRUMENT.

1. Make sure the power source is turned off.
2. Pull power supply wires through conduit connection.

3. Connect the positive supply wire to the (+) terminal, and the negative supply wire to the (-) terminal. Refer to Wiring Diagram (Figure 1).
4. Replace the transmitter housing cover until it is time to calibrate.
5. Connect the positive supply wire to the positive terminal of the power source. Refer to Wiring Diagram (figure 1).

Note: This instrument is designed to operate with a maximum total loop resistance up to 900 ohms at 36 VDC.

PROGRAMMING DESCRIPTION

GENERAL

The LVU-950 series are calibrated via BCD switches. All data entered during the calibration procedure is stored in a nonvolatile memory to prevent loss of data in the event of a power failure.

CALIBRATION PROCEDURE

Unscrew the control unit cover and use the following procedures:

1. Dial zero setting through "top BCD switches" in increments of 1" up to 288" (24 feet) (special unit can be set to an increment of 0.1" up to a span of 99.9") (e.g.: 12" can be set **012** on BCD switches).
2. Dial span setting through "bottom BCD Switches" in increments of 1" to 300" (25 feet) (special unit can be set to an increment of 0.1" up to a span of 99.9") (e.g.: 120" can be set **120** on BCD switches).
3. Set Height/Distance jumper for height or distance mode.
Height Mode : Zero Setting: 20mA
Span Setting: 4mA

Distance Mode : Zero Setting: 4mA
Span Setting: 20mA
4. Turn on the power, the unit is ready for operation.

While the cover is unscrewed, observe lost echo LED. If the unit has not detected a reliable echo for over 10 seconds, the LED will turn on and the unit will draw approximately 22mA indicating an error condition.

CALIBRATION DIAGRAM

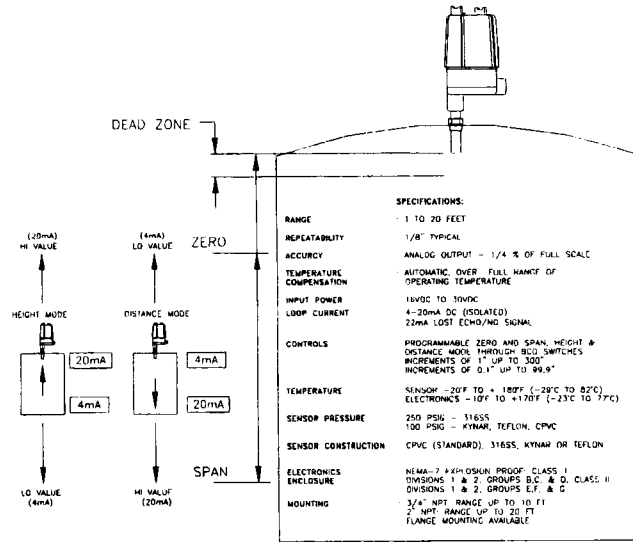

ANALOG OUTPUT SYSTEM

NOTES:

- 1) ZERO CALIBRATED IN INCHES FROM FACE OF SENSOR
- 2) SPAN CALIBRATED IN INCHES FROM THE ZERO POINT
- 3) ALARM POINTS CALIBRATED IN INCHES FROM FACE OF SENSOR
- 4) THE SYSTEM RANGE EQUALS ZERO PLUS SPAN IN INCHES

WIRING DIAGRAM FIGURE 1

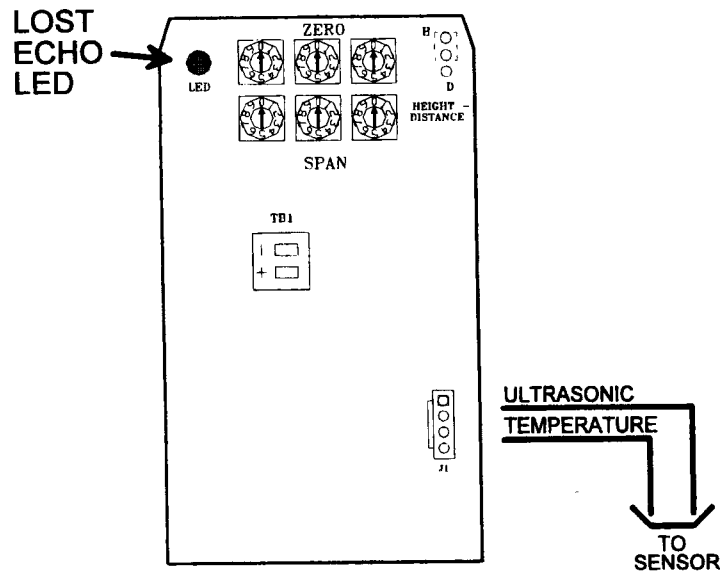

DIMENSIONAL DRAWING

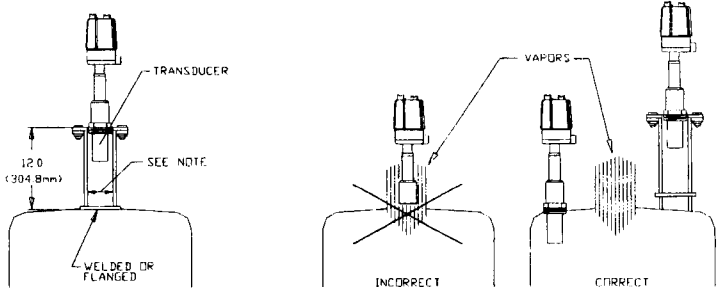
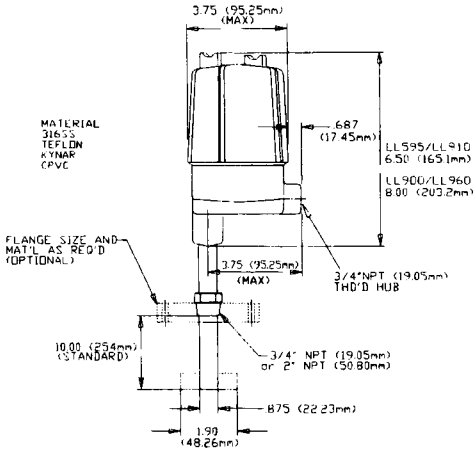

**NOTE: MINIMUM 3" (76.20mm) ID FOR 3/4" (19.05mm) SENSOR
 MINIMUM 6" (152.40mm) ID FOR 2" (50.80mm) SENSOR**

SYSTEM CONFIGURATION DOCUMENT

SITE / LOCATION ID: _____

JOB: _____

UNIT SERIAL NUMBER: _____ DATE: _____

PROGRAMMABLE PARAMETERS PROGRAMMED BY: _____

HEIGHT MODE:

DISTANCE MODE:

ANALOG OFFSET: Y (4-20mA 2-10V)
 N (0-20mA 0-10V)

DISPLAY MODE: 0 1 2

LOST ECHO MODE: 0 1 2

ZERO : _____ INCHES FROM SENSOR FACE

SPAN : _____ INCHES FROM ZERO



WARRANTY/DISCLAIMER

OMEGA ENGINEERING, INC. warrants this unit to be free of defects in materials and workmanship for a period of **13 months** from date of purchase. OMEGA's WARRANTY adds an additional one (1) month grace period to the normal **one (1) year product warranty** to cover handling and shipping time. This ensures that OMEGA's customers receive maximum coverage on each product.

If the unit malfunctions, it must be returned to the factory for evaluation. OMEGA's Customer Service Department will issue an Authorized Return (AR) number immediately upon phone or written request. Upon examination by OMEGA, if the unit is found to be defective, it will be repaired or replaced at no charge. OMEGA's WARRANTY does not apply to defects resulting from any action of the purchaser, including but not limited to mishandling, improper interfacing, operation outside of design limits, improper repair, or unauthorized modification. This WARRANTY is VOID if the unit shows evidence of having been tampered with or shows evidence of having been damaged as a result of excessive corrosion; or current, heat, moisture or vibration; improper specification; misapplication; misuse or other operating conditions outside of OMEGA's control. Components which wear are not warranted, including but not limited to contact points, fuses, and triacs.

OMEGA is pleased to offer suggestions on the use of its various products. However, OMEGA neither assumes responsibility for any omissions or errors nor assumes liability for any damages that result from the use of its products in accordance with information provided by OMEGA, either verbal or written. OMEGA warrants only that the parts manufactured by it will be as specified and free of defects. OMEGA MAKES NO OTHER WARRANTIES OR REPRESENTATIONS OF ANY KIND WHATSOEVER, EXPRESS OR IMPLIED, EXCEPT THAT OF TITLE, AND ALL IMPLIED WARRANTIES INCLUDING ANY WARRANTY OF MERCHANTABILITY AND FITNESS FOR A PARTICULAR PURPOSE ARE HEREBY DISCLAIMED. LIMITATION OF LIABILITY: The remedies of purchaser set forth herein are exclusive, and the total liability of OMEGA with respect to this order, whether based on contract, warranty, negligence, indemnification, strict liability or otherwise, shall not exceed the purchase price of the component upon which liability is based. In no event shall OMEGA be liable for consequential, incidental or special damages.

CONDITIONS: Equipment sold by OMEGA is not intended to be used, nor shall it be used: (1) as a "Basic Component" under 10 CFR 21 (NRC), used in or with any nuclear installation or activity; or (2) in medical applications or used on humans. Should any Product(s) be used in or with any nuclear installation or activity, medical application, used on humans, or misused in any way, OMEGA assumes no responsibility as set forth in our basic WARRANTY/DISCLAIMER language, and, additionally, purchaser will indemnify OMEGA and hold OMEGA harmless from any liability or damage whatsoever arising out of the use of the Product(s) in such a manner.

RETURN REQUESTS/INQUIRIES

Direct all warranty and repair requests/inquiries to the OMEGA Customer Service Department. BEFORE RETURNING ANY PRODUCT(S) TO OMEGA, PURCHASER MUST OBTAIN AN AUTHORIZED RETURN (AR) NUMBER FROM OMEGA'S CUSTOMER SERVICE DEPARTMENT (IN ORDER TO AVOID PROCESSING DELAYS). The assigned AR number should then be marked on the outside of the return package and on any correspondence.

The purchaser is responsible for shipping charges, freight, insurance and proper packaging to prevent breakage in transit.

FOR **WARRANTY RETURNS**, please have the following information available BEFORE contacting OMEGA:

1. Purchase Order number under which the product was PURCHASED,
2. Model and serial number of the product under warranty, and
3. Repair instructions and/or specific problems relative to the product.

FOR **NON-WARRANTY REPAIRS**, consult OMEGA for current repair charges. Have the following information available BEFORE contacting OMEGA:

1. Purchase Order number to cover the COST of the repair,
2. Model and serial number of the product, and
3. Repair instructions and/or specific problems relative to the product.

OMEGA's policy is to make running changes, not model changes, whenever an improvement is possible. This affords our customers the latest in technology and engineering.

OMEGA is a registered trademark of OMEGA ENGINEERING, INC.

© Copyright 1999 OMEGA ENGINEERING, INC. All rights reserved. This document may not be copied, photocopied, reproduced, translated, or reduced to any electronic medium or machine-readable form, in whole or in part, without the prior written consent of OMEGA ENGINEERING, INC.

Where Do I Find Everything I Need for Process Measurement and Control? OMEGA...Of Course!

TEMPERATURE

- Thermocouple, RTD & Thermistor Probes, Connectors, Panels & Assemblies
- Wire: Thermocouple, RTD & Thermistor
- Calibrators & Ice Point References
- Recorders, Controllers & Process Monitors
- Infrared Pyrometers

PRESSURE, STRAIN AND FORCE

- Transducers & Strain Gages
- Load Cells & Pressure Gages
- Displacement Transducers
- Instrumentation & Accessories

FLOW/LEVEL

- Rotameters, Gas Mass Flowmeters & Flow Computers
- Air Velocity Indicators
- Turbine/Paddlewheel Systems
- Totalizers & Batch Controllers

pH/CONDUCTIVITY

- pH Electrodes, Testers & Accessories
- Benchtop/Laboratory Meters
- Controllers, Calibrators, Simulators & Pumps
- Industrial pH & Conductivity Equipment

DATA ACQUISITION

- Data Acquisition & Engineering Software
- Communications-Based Acquisition Systems
- Plug-in Cards for Apple, IBM & Compatibles
- Datalogging Systems
- Recorders, Printers & Plotters

HEATERS

- Heating Cable
- Cartridge & Strip Heaters
- Immersion & Band Heaters
- Flexible Heaters
- Laboratory Heaters

ENVIRONMENTAL MONITORING AND CONTROL

- Metering & Control Instrumentation
- Refractometers
- Pumps & Tubing
- Air, Soil & Water Monitors
- Industrial Water & Wastewater Treatment
- pH, Conductivity & Dissolved Oxygen Instruments