

**1 YEAR**  
WARRANTY

# Ω OMEGA™ User's Guide



***Shop online at  
omega.com***

***e-mail: info@omega.com  
For latest product manuals:  
www.omegamanual.info***

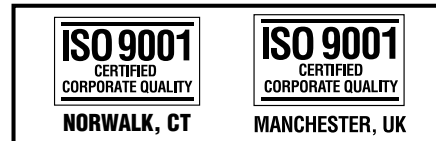

## **TRCIII-A** **ice point™ Calibration** **Reference Chamber**



omega.com info@omega.com

**Servicing North America:**

**U.S.A.  
Headquarters:**

Omega Engineering, Inc.

Toll-Free: 1-800-826-6342 (USA & Canada only)

Customer Service: 1-800-622-2378 (USA & Canada only)

Engineering Service: 1-800-872-9436 (USA & Canada only)

Tel: (203) 359-1660

Fax: (203) 359-7700

e-mail: info@omega.com

**For Other Locations Visit [omega.com/worldwide](http://omega.com/worldwide)**

## Table of Contents

<b>Section .....</b>	<b>Page</b>
<b>Section 1 Introduction .....</b>	<b>1-1</b>
1.1 Precautions .....	1-1
1.2 Safety Warnings and IEC Symbols .....	1-1
1.3 Statement on CE Marking .....	1-2
1.4 General Description .....	1-2
<b>Section 2 Installation .....</b>	<b>2-1</b>
2.1 Unpacking and Inspection .....	2-1
2.2 Mounting .....	2-2
2.3 Ambient Temperature .....	2-2
2.4 Power Connection .....	2-2
<b>Section 3 Operation .....</b>	<b>3-1</b>
3.1 Front Panel Controls and Indicators .....	3-1
3.2 Rear Panel .....	3-2
3.3 Basic Operations .....	3-2
3.4 Applications .....	3-3
<b>Section 4 Maintenance .....</b>	<b>4-1</b>
4.1 Calibration .....	4-1
4.1.1 Main Body .....	4-1
4.1.2 Fan .....	4-1
4.2 Fuse Replacement .....	4-1
<b>Section 5 Accessories .....</b>	<b>5-1</b>
<b>Section 6 Troubleshooting Guide .....</b>	<b>6-1</b>
<b>Section 7 Micro-switch Adjustment procedure .....</b>	<b>7-1</b>
<b>Section 8 Specifications .....</b>	<b>8-1</b>
<b>Section 9 Glossary of Terms Used in This Manual .....</b>	<b>9-1</b>
<b>Section 10 The Omega Family of Blackbody Calibrators .....</b>	<b>10-1</b>



## Table of Figures

<b>Figure Description:</b> .....	<b>Page:</b>
1. I.E.C. Symbols .....	1-2
2. Front Panel Controls and Indicators .....	3-1
3. Rear Panel .....	3-2
4. Tilt positioning for operation (side view) .....	3-3
5. Calibration of an Instrument Using an Ice Point Reference and a BlockCalibrator .....	3-4
6. Calibration of an Instrument Using an Ice Point Reference and a Millivolt Source .....	3-5

## Section 1 - Introduction

Your TRCIII-A Dry Well Ice Point Reference Cell has been designed for ease of use and reliability whenever you require a temperature probe reference at freezing point. It is important that you read this manual completely and follow all safety precautions before operating this instrument.

### 1.1 Precautions

- Follow all safety precautions and operating instructions outlined in this manual.
- Keep out of reach of children.
- Do not operate in flammable or explosive environments.
- This unit is intended for indoor use only. Keep away from environments that contain moisture and humidity.
- Never operate with a power cord other than the one provided with your unit.
- Remove main power cord before attempting any maintenance or fuse replacement.
- Do not connect and or operate this unit to a non-grounded, non-polarized outlet or power source.
- Do not open the unit. There are no user-serviceable parts inside. Opening the unit will void your warranty.
- Line voltage should never exceed  $\pm 10\%$  the power supply rating.
- This unit is designed for “continuous use”.
- If this unit is not used as specified by the instructions in this manual the protection provided by this equipment may be impaired.

### 1.2 Safety Warnings and IEC Symbols

This device is marked with international safety and hazard symbols in accordance with IEC 1010. It is important to read and follow all precautions and instructions in this manual before operating or commissioning this device as it contains important information relating to safety and EMC. Failure to follow all safety precautions may result in injury and or damage to your calibrator. Use of this device in a manner not specified by the manufacturer may impair protection provided within the unit.

IEC symbols

Description

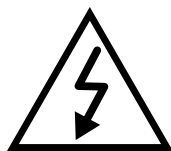

Caution, risk of electric shock



IEC symbols	Description
	Caution, refer to accompanying documents
	230 VAC @50/60Hz (European Models) 115 VAC @50/60Hz (Domestic Models)

Figure 1. IEC symbols

### 1.3 Statement on Marking

It is the policy of Omega™ to comply with all world-wide safety and EMI/EMC regulations that apply. Omega is constantly pursuing certification of its products to the European New Approach Directives.

### 1.4 General Description

The TRCIII-A Dry Well Ice Point Reference Cell is a highly precise instrument providing a temperature reference at precisely 32°F (0°C). The unit provides six 3 ¾" deep wells, 5/32" in diameter. Well temperature is posted on a digital display. And is available in domestic (TRCIII-A) and European models (TRCIII-A-230).

The most common application of the ice point cell is for making a "cold junction" interface between thermocouples and temperature measurement instrumentation.

A list of Omega reference probes and thermometers to be used with the TRCIII-A appears in the "Accessories" section (Section 5).

The TRCIII-A can also be used for temperature testing with a variety of temperature transducers: thermocouple reference junctions, RTD's, thermistors, etc.

## Section 2 Installation

### 2.1 Unpacking

Remove the packing list and verify that you have received all your equipment. If you have any questions about the shipment, please call our Customer Service Department at

1-800-622-2378 or 203-359-1660. We can also be reached on the Internet @ [www.omega.com](http://www.omega.com), e-mail: [info@omega.com](mailto:info@omega.com)

When you receive the shipment, inspect the container and equipment for any signs of damage. Note any evidence of rough handling in transit. Immediately report any damage to the shipping agent.

---

The carrier will not honor any damage claims unless all shipping material is saved for inspection. After examining and removing contents, save packing material and carton in the event reshipment is necessary.

---

The following items are supplied in the box:

- TRCIII-A Dry Well Ice Point Reference Cell
- User's Manual
- Bottle of mineral oil
- Power cord

The following items are supplied in the box:

Item:	Omega Part #:
TRCIII-A Dry Well Ice Point Ref. Cell	TRCIII-A/TRCIII-A-230
Users Manual	M-3390
Calibration Certificate	—
Bottle of Mineral Oil	DIP-0112
Power Cord	200-0028 (Domestic), 200-0107 (European)

## 2.2 Mounting

Mount the unit on a bench, table top or shelf in a tilt position and operate at least 2" from any air obstructions to the fan, front panel, rear panel, and top of the unit (See Figure 4).

## 2.3 Ambient Temperature

The TRCIII-A can maintain "freezing point" in ambient temperatures between 35.6 and 90°F (2 to 32.2°C). Never place the ice point cell in ambient temperatures below freezing, as it will damage the temperature control mechanism inside of the unit. The ice point cell is not capable of maintaining its "freezing point" temperature in ambient temperatures exceeding 90°F (32.2°C).

## 2.4 Power Connection

Standard (115 Vac~, 60 Hz models)

The TRCIII-A comes with a standard North American 3-prong AC power cord. Do not use any other power cord other than the one provided. This cord provides the proper grounding and has been safety tested by the proper safety agencies.

**Domestic (230 Vac~, 50 Hz models)**

On 230 VAC~, 50Hz models a European style power cord with the proper color code and approvals is provided with stripped wire ends for connection to the proper connector used in your country or local area, this connector is not provided.

- 
- Never defeat the power cord's grounding lug.
  - Always use an outlet equipped with a grounding socket.
  - Line voltage should never exceed  $\pm 10\%$  the power supply rating.
- 

---

Electrical connections and wiring should be performed only by suitably trained personnel.

---



## Section 3 Operation

### 3.1 Front Panel Controls and Indicators

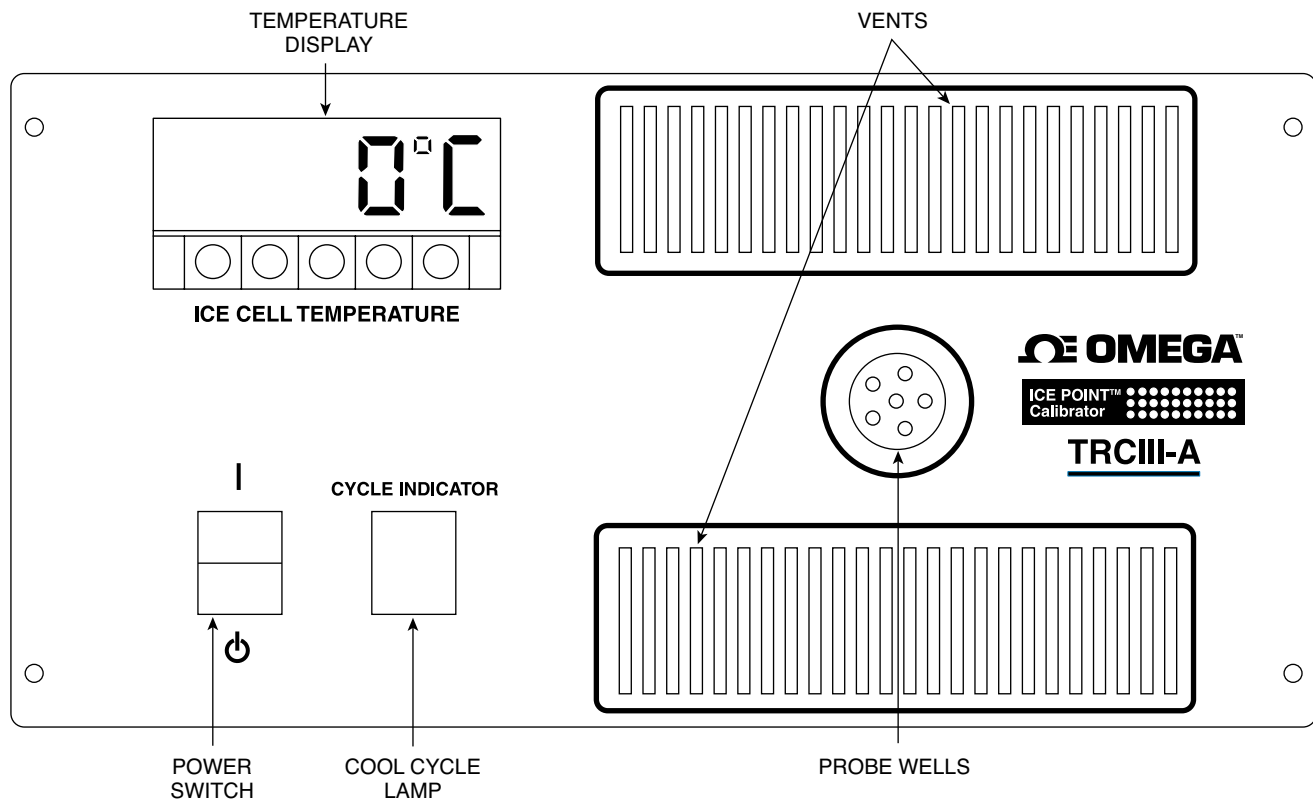

Figure 2. Front Panel

#### Power Switch:

The unit is turned on and off using the rocker switch. The switch is illuminated when the power is on.

#### Temperature Display:

The temperature display shows the temperature of the probe well. This display is for reference only. Fluctuations in the display temperature may occur from time to time. Despite these occasional fluctuations, the probe well temperature is kept at freezing within the published accuracy and stability specifications.

#### Cool Cycle Lamp:

The cool cycle lamp is illuminated whenever the ice point reference cell is in its refrigeration mode. After the initial cool-down phase, the lamp will illuminate periodically. The period may vary from 30 seconds to 2 minutes. This is required to maintain the ice point cell precisely at "freezing point."

#### Probe Wells:

Six  $\frac{5}{32}$ " I.D.  $3\frac{3}{4}$ " deep wells are provided on the front panel which accept  $\frac{1}{8}$ " diameter probes. The wells are chassis grounded to minimize electrical noise pickup.

### 3.2 Rear Panel

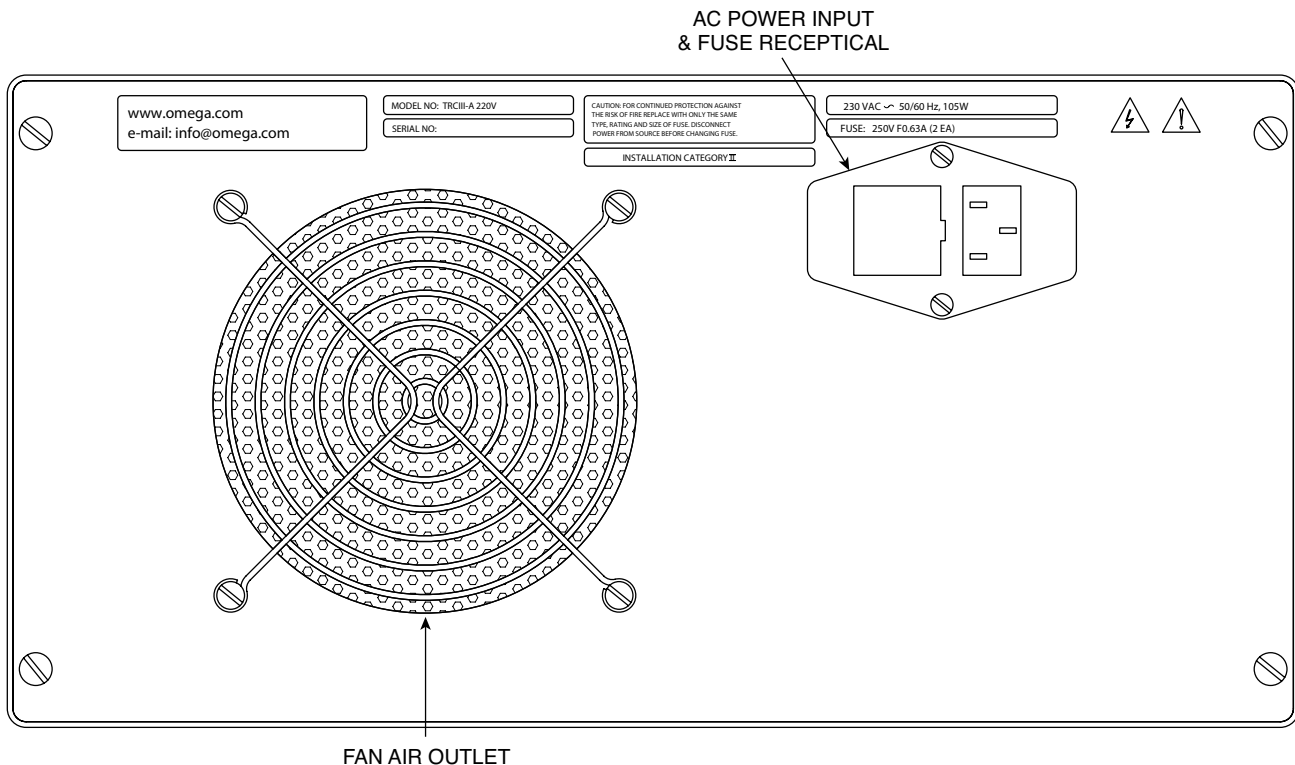

Figure 3. Rear Panel

### 3.3 Basic Operation

1. Add 3 to 4 drops of mineral oil or other heat transfer fluid to each of the 6 probe wells. The oil improves the thermal interface between the probes and the probe well.
2. Be sure to have the unit in a tilt position during operation so that the mineral oil does not drip out of the unit. (See Figure 4).
3. Place the ice point reference cell on a surface, leaving at least 2" space around the unit. **Never obstruct any of the air vents on the unit.** Be sure that the environment is between 35.6 to 90 °F (2 to 32.2 °C) and no higher than 90% RH, non-condensing.
4. Plug in the unit's power cord, being sure to use a socket with a ground lug. Insert reference probes into the probe wells, being sure that the probe tips are making contact with the bottom of the wells. Allow 30 minutes for the temperature to stabilize at "freezing point."
5. The probe wells are electrically connected to "earth ground" the the 3-wire power cord. **Never defeat the grounding lug. Always use an outlet equipped with a grounding socket.**

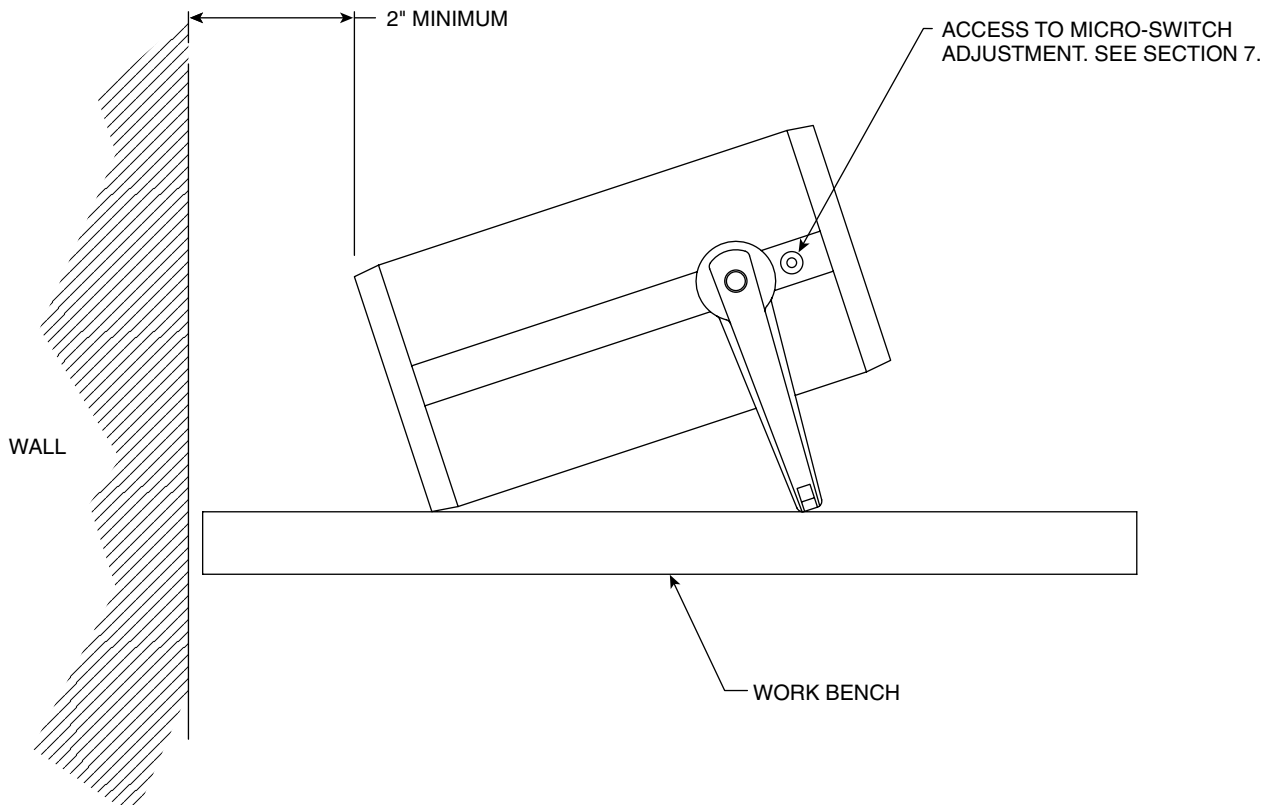

Figure 4. Tilt positioning for operation (side view)

The greater the number of probes inserted into the ice point cell the greater the thermal load on the TRCIII-A. While the unit is designed to maintain “freezing point” for 6 probes, performance could be compromised at elevated ambient temperatures.

### 3.4 Applications

An ice point reference cell is most commonly used in temperature measurement instrumentation calibrations. The function of the ice point reference itself in such a system is to provide a highly effective cold junction between a thermocouple and a DMM. The cold junction assures that there is no EMF generated at the junction between thermocouple leads and the DMM input. In practice, this is achieved by connecting thermocouple leads to copper leads via TRP probes which have been inserted into the ice point reference cell.

Figure 5 shows the ice point in as it is used in the field. Calibration of the system consists of comparing the temperature of the standard probe, which is measured in millivolts by the 5 ½ digit DMM, to the temperature shown on the temperature instrument. Note that in Figure 5, J type thermocouples were chosen for illustration.

It is more desirable to connect the DMM to the probe that it will normally be used with during operation.

The "System Calibration" procedure would be as follows:

1. The temperature instrument is first electronically calibrated to its specifications following the procedure in the Operator's Manual.
2. The temperature probe is then compared to the "Standard" probe at various temperature points requested.
3. A Certificate of Calibration is issued with a listing of the deviations from these points to the "Standard."

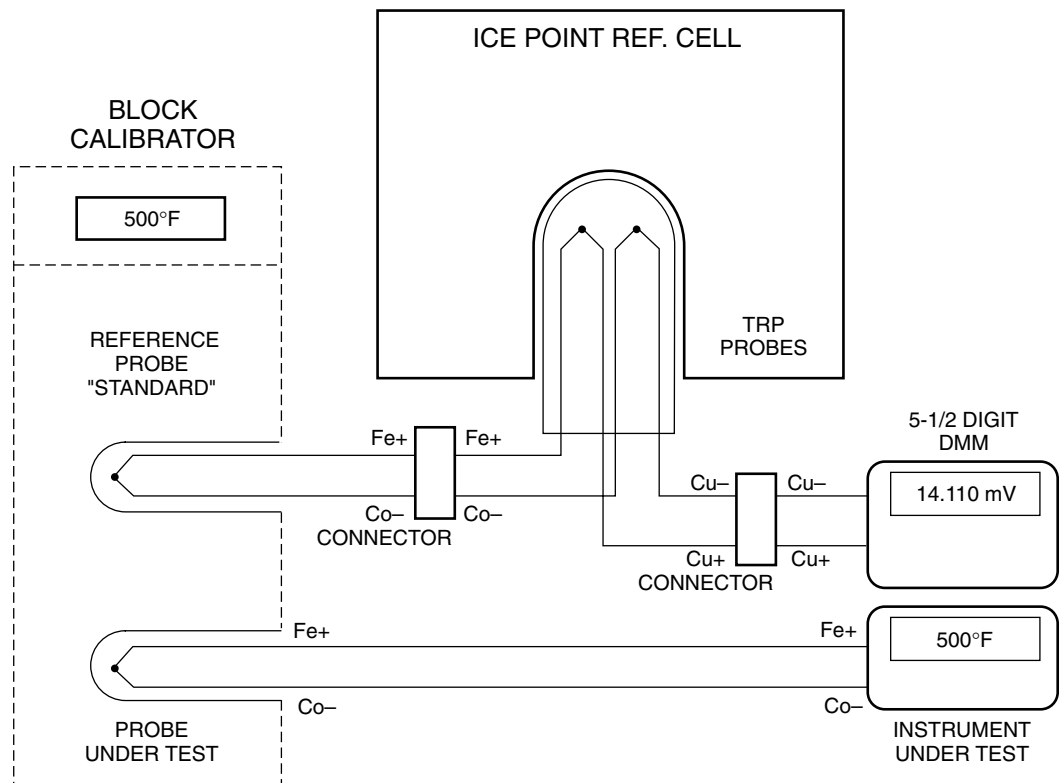

**Figure 5. Calibration of an Instrument Using an Ice Point Reference and a Block Calibrator**

Figure 6 shows another common setup involving an ice point reference cell. Here, a millivolt source is used to simulate a thermocouple's output. The copper lead wires are then interfaced to the iron-constantan lead wires via the TRP probes. The TRP probes are, in effect, a cold junction since they are inside of the ice point reference cell. The temperature measurement instrument can now be calibrated.

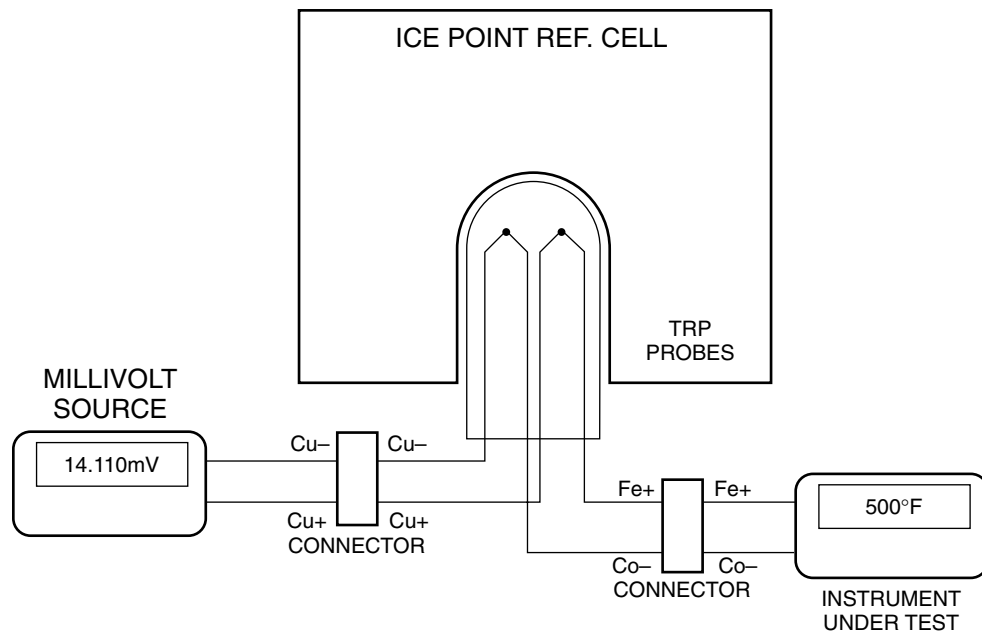

**Figure 6. Calibration of an Instrument Using an Ice Point Reference and a Millivolt Source**

## Section 4 Maintenance

### 4.1 Cleaning

---

Remove all electrical connections and power before attempting any maintenance or cleaning

---

#### 4.1.1 Main Body

Only a damp soft rag with a mild cleaning solution should be used when cleaning the main body of this unit.

#### 4.1.2 Fan

The TRCIII-A uses a fan for ventilation, It is mounted to the inside of the back panel. The fan draws air into the unit. Use a soft bristle brush or a vacuum to clean the fan inlet. In normal environments clean the fan inlet once a year. In dusty environments clean the fan inlet twice a year.

### 4.2 Fuse replacement

---

For continued protection against the risk of fire replace with only the same size, type and rating fuse indicated here and on the rear panel of your unit.

---

#### User Replaceable Fuses (Externally Mounted):

For model TRCIII-A use	1 ea. 250 VAC~, T1.5A (Time-Lag, 1.5 Amp) UL/CSA Approved (.25" dia. x 1.25" long)
For model TRCIII-A-230 use	2 ea. 250 VAC~, T.63A (Time-Lag, 0.63 Amp) VDE Approved (5 mm dia. x 20 mm long)

#### Non-User Replaceable Fuses (Internally Mounted):

For model TRCIII-A use	2 ea. 250 VAC~, T1A (Time-Lag, 1 Amp) UL/CSA Approved (.25" dia. x 1.25" long)
For model TRCIII-A-230 use	2 ea. 250 VAC~, T500mA (Time-Lag, 0.63 Amp) VDE Approved (5 mm dia. x 20 mm long)

Before replacing fuse(s) disconnect the power from your unit. In order to replace the fuses, remove the power cord and pry open the power module door with a screwdriver. Remove the red block, using the screwdriver, again. Note, this fuseblock has an orientation. In the TRCIII-A (115 VAC) only one fuse is used, interrupting the "hot" line. The neutral line is bridged with a jumper. In the TRCIII-A-230V. 2 fuses are used, interrupting the "hot" and "neutral" lines.

## Section 5 Accessories

The following is a list of accessories that are available from Omega for the TRCIII-A. Before buying a reference probe, determine which type of test probe you are using (i.e. K, J, E, etc.). The precision mercury probe is a graduated thermometer. It may be ordered with or without an N.I.S.T. certification sheet.

Model #:	Item:
TRP-K	K-type thermocouple probe (CHROMEGA™-ALOMEGA™)
TRP-J	J-type thermocouple probe (Iron-Constantan)
TRP-E	E-type thermocouple probe (CHROMEGA™-Constantan)
TRP-S	S-type thermocouple probe (Pt10%-Rh vs. Pt)
TRP-R	R-type thermocouple probe (Pt13%-Rh vs. Pt)
TRP-B	B-type thermocouple probe (Pt30%-Rh vs. Pt6%-Rh)
TRP-G	G-type thermocouple probe (W vs. W-Re26%)
TRP-C	C-type thermocouple probe (W-Re5% vs. W-Re26%)
TRP-D	D-type thermocouple probe (W-Re3% vs. W-Re56%)
TRP-PT	Precision mercury probe
TRP-PT-NIST	Precision mercury probe with N.I.S.T. certificate

## Section 6 Troubleshooting Guide

SYMPTOM:	DIAGNOSIS / CORRECTIVE ACTION:
<p>Unit does not power up.</p> <p>Refer to the "Maintenance" section replacement.</p>	<p>Is the unit plugged in? One or both fuses may have been blown. (Section 4) for directions on</p>
<p>Unit does not maintain temperature at freezing point (32°F/0°C).</p> <p>Was the unit exposed to sub-freezing temperatures during storage or operation?</p>	<ul style="list-style-type: none"> <li>• The TRCIII-A may be out of calibration. Refer to "Microswitch Adjustment Procedure" (Section 7)</li> <li>• If so, the thermostat switch may have been damaged and will require service. Send your unit back to Omega for service.</li> </ul>



## Section 7 Micro-Switch Adjustment Procedure.

The TRCIII-A. Ice Point Reference Cell has been designed for years of continuous, trouble-free operation. No periodic maintenance is required.

However, in case the unit fails to maintain a reading of 32°F/0°C. It indicates that the micro-switch may need adjustment.

Before attempting to adjust the micro-switch, The Ice point reference cell must be shut off for a period of at least 5 hours, or until the cell temperature reaches ambient temperature.

Then, **carefully proceed as follows:**

- Locate the adjustment access hole. It is located on the left side of the unit, adjacent to the handle pivot. - see figure 4
- The adjustment screw can be reached **without removing the black plug.**  
Use a flat blade screw driver with a shaft length of at least 2 ¾"
- Plug the unit to the appropriate power source. (115 or 230 Vac).
- Turn the unit ON.
- Verify the "Cool Cycle Lamp" in the front panel, is ON or OFF.

If the Lamp is ON make the following adjustments:

- Slowly, turn screw clockwise, until the "Cool Cycle Lamp" turns OFF.
- Slowly, turn screw counterclockwise, until the lamp comes ON. And
- Slowly, continue to make an additional 6 complete turns.
- Adjustment is complete.

---

If the "Cool Cycle Lamp" remains lit during this adjustment procedure, the Ice Point Reference Cell **MUST BE** returned to OMEGA for repair.

---

If the Lamp is OFF make the following adjustments:

- Slowly, turn screw counterclockwise, until the "Cool Cycle Lamp" turns ON.  
And,
- Slowly, continue to make an additional 6 complete turns.
- Adjustment is complete.

If none of the above procedures correct the condition, contact the Omega Customer Service Department at 1-800-TC-OMEGA (1-800-826-6342) for help and assistance on returning your TRCIII-A. Ice Point Reference Cell.

**Section 8 Specifications.**

<b>Reference Wells:</b>	Six 5/2" I.D. 3 3/4" deep wells. Accepts 1/8" dia. probes.
<b>Ambient Environmental Conditions:</b>	
<b>Temperature:</b>	2 to 32.2°C (35.6 to 90°F)
<b>Humidity:</b>	Up to 90% RH, non-condensing
<b>Power:</b>	
TRCIII-A	*115 VAC~, 50/60 Hz, 104W
TRCIII-A-230VAC	*230 VAC~, 50/60 Hz, 104W
<b>Internal Control Sensor:</b>	Thermocouple, T-type
<b>Well Accuracy (@72°F ambient temp.):</b>	±0.1°C (±0.18°F), or better.
<b>Display Resolution:</b>	±0.1°C (±.1°F), for reference only
<b>Well Stability:</b>	±0.03°C (±0.05°F) for constant ambient temp.
<b>Cool-Down Time:</b>	30 min. required for stabilization. Cooled from ambient (20°C/68°F) to (0°C/32°F).
<b>Dimensions:</b>	203 MM H, 419 MM W, 304 MM D 8" H, 16.5" W, 12" D
<b>Weight:</b>	12.7 Kg. (28 lbs.)

**\*Line voltage should never exceed ±10% the power supply rating.**

---

## Section 9 Glossary of Terms Used in This Manual

C.S.A. – Canadian Standards Association

D.M.M. – digital multi-meter

E.M.C. – electromagnetic compatibility

E.M.F. – electromotive force (voltage)

I.E.C. – International Electrotechnical Commission

N.I.S.T. – National Institute of Standards and Technology

R.T.D. – resistive temperature detector

U.L. – Underwriter's Laboratory

V.D.E. – Verband Deutscher Electrotechniker (Germany)

## Section 10. The Omega™ Family of Dry Block Probe Calibrators

Below is a selection guide of Omega's line of dry block probe calibrators. This family of rugged, portable, highly accurate calibrators covers a wide range of temperatures, well sizes and features making them perfect for temperature probe testing and calibration.

---

**Model:** CL1000 Miniature Dry Block Probe Calibrator  
**Temperature Range:** ambient +10 to 260°C (ambient +20 to 500°F)  
**Accuracy:** ±1.5°C  
**Control Stability:** --- **Power:** 115/230V, 50/60 Hz, 275W  
**Features:** Low cost, Rugged benchtop design, available in 4 configurations

---

**Model:** CL900A hot point® Dry Block Probe Calibrator  
**Temperature Range:** ambient +22 to 482°C (ambient +40 to 900°F)  
**Accuracy:** ±0.8°C (±1.5°F) w/6" inserts / ±1.7°C (±3.0°F) w/4" inserts  
**Control Stability:** ±0.2°C (±0.3°F) **Power:** 115/230V, 50/60 Hz, 1217W  
**Features:** Removable insert, Rugged benchtop design, RS-232 interface

---

**Model:** CL950A/CL950A-M hot point® Dry Block Probe Calibrator  
**Temperature Range:** ambient +22 to 482°C (ambient +40 to 900°F)  
**Accuracy:** ±0.8°C (±1.5°F) w/6" inserts / ±1.7°C (±3.0°F) w/4" inserts  
**Control Stability:** ±0.2°C (±0.3°F) **Power:** 115/230V, 50/60 Hz, 1217W  
**Features:** Probe well accepts 4 probe sizes, Rugged benchtop design, RS-232 interface

---

**Model:** TRCIII A ice point® Calibration Reference Chamber  
**Temperature Range:** Fixed @ 0°C (32 °F)  
**Accuracy:** ±0.1°C (±0.18°F)  
**Control Stability:** ±0.03°C **Power:** 115 or 230V, 50/60 Hz, 104W  
**Features:** Digital display, Rugged portable/benchtop design

---

Complete product specifications and features for these and additional calibrators can found and downloaded from our web site. Visit us at [www.omega.com](http://www.omega.com)

## WARRANTY/DISCLAIMER

OMEGA ENGINEERING, INC. warrants this unit to be free of defects in materials and workmanship for a period of **13 months** from date of purchase. OMEGA's WARRANTY adds an additional one (1) month grace period to the normal **one (1) year product warranty** to cover handling and shipping time. This ensures that OMEGA's customers receive maximum coverage on each product.

If the unit malfunctions, it must be returned to the factory for evaluation. OMEGA's Customer Service Department will issue an Authorized Return (AR) number immediately upon phone or written request. Upon examination by OMEGA, if the unit is found to be defective, it will be repaired or replaced at no charge. OMEGA's WARRANTY does not apply to defects resulting from any action of the purchaser, including but not limited to mishandling, improper interfacing, operation outside of design limits, improper repair, or unauthorized modification. This WARRANTY is VOID if the unit shows evidence of having been tampered with or shows evidence of having been damaged as a result of excessive corrosion; or current, heat, moisture or vibration; improper specification; misapplication; misuse or other operating conditions outside of OMEGA's control. Components in which wear is not warranted, include but are not limited to contact points, fuses, and triacs.

**OMEGA is pleased to offer suggestions on the use of its various products. However, OMEGA neither assumes responsibility for any omissions or errors nor assumes liability for any damages that result from the use of its products in accordance with information provided by OMEGA, either verbal or written. OMEGA warrants only that the parts manufactured by the company will be as specified and free of defects. OMEGA MAKES NO OTHER WARRANTIES OR REPRESENTATIONS OF ANY KIND WHATSOEVER, EXPRESSED OR IMPLIED, EXCEPT THAT OF TITLE, AND ALL IMPLIED WARRANTIES INCLUDING ANY WARRANTY OF MERCHANTABILITY AND FITNESS FOR A PARTICULAR PURPOSE ARE HEREBY DISCLAIMED. LIMITATION OF LIABILITY: The remedies of purchaser set forth herein are exclusive, and the total liability of OMEGA with respect to this order, whether based on contract, warranty, negligence, indemnification, strict liability or otherwise, shall not exceed the purchase price of the component upon which liability is based. In no event shall OMEGA be liable for consequential, incidental or special damages.**

CONDITIONS: Equipment sold by OMEGA is not intended to be used, nor shall it be used: (1) as a "Basic Component" under 10 CFR 21 (NRC), used in or with any nuclear installation or activity; or (2) in medical applications or used on humans. Should any Product(s) be used in or with any nuclear installation or activity, medical application, used on humans, or misused in any way, OMEGA assumes no responsibility as set forth in our basic WARRANTY/DISCLAIMER language, and, additionally, purchaser will indemnify OMEGA and hold OMEGA harmless from any liability or damage whatsoever arising out of the use of the Product(s) in such a manner.

## RETURN REQUESTS/INQUIRIES

Direct all warranty and repair requests/inquiries to the OMEGA Customer Service Department. BEFORE RETURNING ANY PRODUCT(S) TO OMEGA, PURCHASER MUST OBTAIN AN AUTHORIZED RETURN (AR) NUMBER FROM OMEGA'S CUSTOMER SERVICE DEPARTMENT (IN ORDER TO AVOID PROCESSING DELAYS). The assigned AR number should then be marked on the outside of the return package and on any correspondence.

The purchaser is responsible for shipping charges, freight, insurance and proper packaging to prevent breakage in transit.

FOR **WARRANTY** RETURNS, please have the following information available BEFORE contacting OMEGA:

1. Purchase Order number under which the product was PURCHASED,
2. Model and serial number of the product under warranty, and
3. Repair instructions and/or specific problems relative to the product.

FOR **NON-WARRANTY** REPAIRS, consult OMEGA for current repair charges. Have the following information available BEFORE contacting OMEGA:

1. Purchase Order number to cover the COST of the repair,
2. Model and serial number of the product, and
3. Repair instructions and/or specific problems relative to the product.

OMEGA's policy is to make running changes, not model changes, whenever an improvement is possible. This affords our customers the latest in technology and engineering.

OMEGA is a trademark of OMEGA ENGINEERING, INC.

© Copyright 2018 OMEGA ENGINEERING, INC. All rights reserved. This document may not be copied, photocopied, reproduced, translated, or reduced to any electronic medium or machine-readable form, in whole or in part, without the prior written consent of OMEGA ENGINEERING, INC.

# Where Do I Find Everything I Need for Process Measurement and Control? **OMEGA...Of Course!** *Shop online at [omega.com](http://omega.com)*

## **TEMPERATURE**

- ☑ Thermocouple, RTD & Thermistor Probes, Connectors, Panels & Assemblies
- ☑ Wire: Thermocouple, RTD & Thermistor
- ☑ Calibrators & Ice Point References
- ☑ Recorders, Controllers & Process Monitors
- ☑ Infrared Pyrometers

## **PRESSURE, STRAIN AND FORCE**

- ☑ Transducers & Strain Gages
- ☑ Load Cells & Pressure Gages
- ☑ Displacement Transducers
- ☑ Instrumentation & Accessories

## **FLOW/LEVEL**

- ☑ Rotameters, Gas Mass Flowmeters & Flow Computers
- ☑ Air Velocity Indicators
- ☑ Turbine/Paddlewheel Systems
- ☑ Totalizers & Batch Controllers

## **pH/CONDUCTIVITY**

- ☑ pH Electrodes, Testers & Accessories
- ☑ Benchtop/Laboratory Meters
- ☑ Controllers, Calibrators, Simulators & Pumps
- ☑ Industrial pH & Conductivity Equipment

## **DATA ACQUISITION**

- ☑ Communications-Based Acquisition Systems
- ☑ Data Logging Systems
- ☑ Wireless Sensors, Transmitters, & Receivers
- ☑ Signal Conditioners
- ☑ Data Acquisition Software

## **HEATERS**

- ☑ Heating Cable
- ☑ Cartridge & Strip Heaters
- ☑ Immersion & Band Heaters
- ☑ Flexible Heaters
- ☑ Laboratory Heaters

## **ENVIRONMENTAL MONITORING AND CONTROL**

- ☑ Metering & Control Instrumentation
- ☑ Refractometers
- ☑ Pumps & Tubing
- ☑ Air, Soil & Water Monitors
- ☑ Industrial Water & Wastewater Treatment
- ☑ pH, Conductivity & Dissolved Oxygen Instruments