

Digital Pressure Gauges

DPG1000B, DPG1001B, DPG1000BBL,
DPG1100B, DPG1100BBL

INSTRUCTION SHEET

M3359/0818

Shop online at omega.com e-mail: info@omega.com
For latest product manuals: www.omegamanual.info



DPG1000B,
DPG1001B,
DPG1000BBL



DPG1100B,
DPG1100BBL



DPG1000B,
DPG1000BBL
Ranges above
2000



DPG1100B,
DPG1100BBL
Ranges above
2000

- DPG1000B Battery Powered
- DPG1001B Battery Powered, High Accuracy
- DPG1000BBL Battery Powered w. Backlighting
- DPG1100B Battery Powered, NEMA 4X
- DPG1100BBL Battery Powered w. Backlighting, NEMA 4X



Ranges and Resolution

Resolution is fixed as indicated in table.

Resolution is limited by number of display digits. 2, 20, 200, and 2000 ranges display 1.999, 19.99, 199.9, and 1999.

Bold Standard ranges. Contact Omega Engineering to order other ranges listed below.

G Gauge reference pressure

VAC Vacuum gauge, minus sign not used unless specified

A Absolute reference (normally reads atmospheric pressure, reads zero at full vacuum)

‡ DPG1001B not available in 3 psi, 5 psi, vacuum, bipolar ranges, and ranges with insufficient digits.

* 4 digit range. All others 3-1/2 digit.

Batteries

2 AA alkaline, included

Battery Life

1000B, 1001B, 1100B ranges to 1999

Approx. 2500 hours

1000B, 1001B, 1100B ranges 2000 and up

Approx. 2000 hours

1000BBL, 1100BBL ranges to 1999

Approx. 180 hrs (backlight on when gauge is on)

1000BBL, 1100BBL 2000 and up

Approx. 150 to 1500 hrs depending on backlight usage

Low Battery Indication

Low battery symbol on display when batteries must be replaced

Connection and Material

1/4" NPT male fitting, 316L stainless steel

All wetted parts are 316L stainless steel

Dimensions (see drawing on next page)

DPG1000, DPG1001

3.38" W x 2.88" H x 1.65" D housing

Add approx. 0.75" to height for pressure fitting

DPG1100

3.5" W x 3.0" H x 2.0" D NEMA 4X housing

Add approx. 0.75" to height for pressure fitting

Weight (approximate)

Gauge: 9 ounces

Shipping weight: 1 pound

Housing Material & Color

DPG1000, DPG1001

Extruded aluminum case, light gray epoxy powder coated, black ABS/polycarbonate bezel, front and rear gaskets, polycarbonate label

DPG1100

Light gray ABS/polycarbonate NEMA 4X case, rear gasket, polycarbonate label

Overpressure, Burst, Vacuum

Ranges using 3000 psig sensor: 5000 psig

Ranges using 5000 psig sensor: 7500 psig

All others: 2 X pressure range

3000 psi, 5000 psi, and 4 digit ranges 112.5% full scale out-of-range display: 1- - - - or 1- - - - -
4 X sensor burst pressure rating, or 10,000 psi, whichever is less

Vacuum service: ±15 psig, 15 psig, 15 psia, 30 psia, 100 psig, 100 psia, 200 psig sensors.

3000 psi, 5000 psi, and 4 digit ranges: Under-range display (non-vacuum sensors): --Err

Environmental

Storage temperature: -40 to 203°F (-40 to 95°C)

Operating (3.5 digit versions): -40 to 185°F (-40 to 85°C)

Operating (4 digit versions): -4 to 185°F (-20 to 85°C)

Compensated range: 32 to 158°F (0 to 70°C)

PSI	Res	inHg/PSI	Res	mmH2O	Res
3PSIG‡	.01	-30V15PSIG‡	.1	2000MMH2OG‡	1
5PSIG‡	.01	-30V100PSIG‡	.1	3500MMH2OG‡	1
15PSIA	.01	-30V200PSIG‡	.1	cmH2O	Res
15PSIVAC‡	.01	inH2O	Res	200CMH2OG‡	.1
±15PSIG‡	.1	85INH2OG‡	.1	350CMH2OG‡	1
15PSIG	.01	140INH2OG‡	.1	1000CMH2OA	1
30PSIA	.1	400INH2OA	1	1000CMH2OVAC‡	1
30PSIG‡	.1	400INH2OVAC‡	1	±1000CMH2OG‡	1
60PSIG	.1	±400INH2OG‡	1	1000CMH2OG	1
100PSIA	.1	400INH2OG	1	2000CMH2OA	1
-15V100PSIG‡	.1	850INH2OA	1	2000CMH2OG	1
100PSIG	.1	850INH2OG	1	kPa	Res
-15V200PSIG‡	.1	ftH2O	Res	20KPAG‡	.01
200PSIG	.1	7FTH2O‡	.01	35KPAG‡	.1
300PSIG‡	1	12FTH2O‡	.01	100KPAA	.1
500PSIG	1	35FTH2O‡	.1	100KPAVAC‡	.1
1000PSIG	1	70FTH2O	.1	±100KPAG‡	.1
2000PSIG	1	140FTH2O	.1	100KPAG	.1
3000PSIG	1	230FTH2O‡	1	200KPAA	.1
5000PSIG	1	480FTH2O	1	200KPAG	.1
oz/in²	Res	70FTH2O	1	400KPAG	1
50ZING‡	.1	1150FTH2O	1	700KPAA	1
80ZING‡	.1	2300FTH2O*	1	700KPAG	1
240ZINA‡	1	4600FTH2O*	1	-100V700KPAG‡	1
240ZINVAC‡	1	6900FTH2O*	1	1400KPAG	1
±240ZING‡	1	mmHg	Res	-100V1400KPAG‡	1
240ZING‡	1	150MMHGG‡	.1	2000KPAG	1
480ZINA	1	260MMHGG‡	.1	3500KPAG*	1
480ZING	1	760MMHGA	1	7000KPAG*	1
inHg	Res	760MMHGVAC‡	1	MPa	Res
6INHGG‡	.01	±760MMHGG‡	1	1.4MPAG	.001
10INHGG‡	.01	760MMHGG	1	-0.1V1.4MPAG‡	.001
30INHGA‡	.1	1600MMHGA	1	2MPAG	.001
30INHGVAC‡	.1	1600MMHGG	1	3.5MPAG‡	.01
±30INHGG‡	.1	Torr	Res	7MPAG	.01
30INHGG‡	.1	760TORRA	1	14MPAG	.01
60INHGA	.1	760TORRVAC‡	1	20MPAG	.01
60INHGG	.1	1600TORRA	1	35MPAG‡	.1
120INHGG	.1	mbar	Res	g/cm²	Res
200INHGA	.1	200MBARG‡	.1	200GCMG‡	.1
-30V200INHGG‡	.1	350MBARG‡	1	350GCMG‡	1
200INHGG	.1	1000MBARA	1	1000GCMG	1
-30V400INHGG‡	1	1000MBARVAC‡	1	1000GCMVAC‡	1
400INHGG	1	±1000MBARG‡	1	±1000GCMG‡	1
600INHGG	1	1000MBARG	1	1000GCMG	1
1000INHGG	1	2000MBARA	1	2000GCMG	1
2000INHGG	1	2000MBARG	1	2000GCMG	1
4000INHGG*	1				

atm	Res	bar	Res	kg/cm ²	Res
1ATMA	.001	1BARA	.001	1KGCMG	.001
1ATMVAC‡	.001	1BARVAC‡	.001	1KGCMVAC‡	.001
±1ATMG‡	.001	±1BARG‡	.001	±1KGCMG‡	.001
1ATMG	.001	1BARG	.001	1KGCMG	.001
2ATMA	.001	2BARA	.001	2KGCMG	.001
2ATMG	.001	2BARG	.001	2KGCMG	.001
4ATMG	.01	4BARG	.01	4KGCMG	.01
7ATMA	.01	7BARA	.01	7KGCMG	.01
7ATMG	.01	7BARG	.01	7KGCMG	.01
-1V7ATMG‡	.01	-1V7BARG‡	.01	-1V7KGCMG‡	.01
14ATMG	.01	14BARG	.01	14KGCMG	.01
-1V14ATMG‡	.01	-1V14BARG‡	.01	-1V14KGCMG‡	.01
20ATMG	.01	20BARG	.01	20KGCMG	.01
34ATMG‡	.1	35BARG‡	.1	35KGCMG‡	.1
70ATMG	.1	70BARG	.1	70KGCMG	.1
140ATMG	.1	140BARG	.1	140KGCMG	.1
200ATMG	.1	200BARG	.1	200KGCMG	.1
340ATMG‡	1	350BARG‡	1	350KGCMG‡	1

Accuracy (linearity, hysteresis, repeatability)

±0.25% of full scale ±1 least significant digit

DPG1001B: ±0.10% of full scale ±1 least significant digit

Sensor hysteresis: ±0.015% FS, included in accuracy

Sensor repeatability: ±0.01% FS, included in accuracy

Display (update rate, type, size)

3 readings per second nominal display update

Ranges up to 1999: 3-1/2 digit LCD, 1/2" digit height

Ranges 2000 and up: 4 digit LCD, 0.4" H digits, alphanumeric display of units

BBL: Red LED display backlighting

Controls & Functions

Ranges up to 1999: Front pushbutton turns gauge on/off and starts shutoff timer. Turns on backlighting for 1 minute on BBL models.

Ranges 2000 and up: Front pushbutton turns gauge on/off, starts shutoff timer. Pressing and holding front button zeros gauge. The zero feature is not used on absolute reference gauges.

Calibration

Ranges up to 1999: Front potentiometers, non-interactive zero & span, ±10% range

Ranges 2000 and up: Internal pushbuttons, non-interactive zero, midpoint, span, ±10% range. Calibration information stored in non-volatile memory.

Shutoff

Last character of model number on rear label indicates shutoff time. Contact Omega for other optional shutoff times.

-5: 5 minute auto shutoff (standard)

-NS: No auto shutoff, on/off via front pushbutton

CAUTION:**Installation and Precautions**

- ✓ Read these instructions before using the gauge. Contact the factory for assistance.
- ✓ These products do not contain user-serviceable parts. Contact us for repairs, service, or refurbishment.
- ✓ Gauges must be operated within specified ambient temperature ranges.
- ✓ Outdoor or wash down applications require a NEMA 4X gauge or installation in a NEMA 4X housing.
- ✓ Use a pressure or vacuum range appropriate for the application.
- ✓ Use fittings appropriate for the pressure range of the gauge.
- ✓ Due to the hardness of 316 stainless steel, it is recommended that a thread sealant be used to ensure leak-free operation.
- ✓ For contaminated media use an appropriate screen or filter to keep debris out of gauge port.
- ✓ Remove system pressures before removing or installing gauge.
- ✓ Install or remove gauge using a wrench on the hex fitting only. Do not attempt to turn gauge by forcing the housing.
- ✓ Good design practice dictates that positive displacement liquid pumps include protection devices to prevent sensor damage from pressure spikes, acceleration head, and vacuum extremes.
- ✗ Avoid permanent sensor damage! Do not apply vacuum to non-vacuum gauges or hydraulic vacuum to any gauges.
- ✗ Avoid permanent sensor damage! NEVER insert objects into gauge port or blow out with compressed air.
- ⚠ Gauges are not for oxygen service. Accidental rupture of sensor diaphragm may cause silicone oil inside sensor to react with oxygen.



WARNING: This product can expose you to chemicals including nickel and chromium, which are known to the State of California to cause cancer or birth defects or other reproductive harm. For more information go to www.P65Warnings.ca.gov

Absolute Reference Gauges

These models have engineering units shown on the rear label such as PSIA, INHGA, INH20A, ZIN2A, BARA, MBARA, KPAA, TORR or TORRA, MMHGA, KGCMA, ATMA. The "A" indicates absolute reference. These ranges display atmospheric pressure when the gauge port is open to the atmosphere. They display zero at high vacuum.

When the gauge port is open to the atmosphere, it is normal for the reading to constantly change in response to atmospheric pressure changes. Do not adjust the calibration controls!

Operation – Ranges up to 1999

Press the round button on the front of the gauge to activate the display. The gauge will stay on for a period of time determined by the auto-shutoff time. The gauge can be shut off at any time by pressing the button again.

If the gauge was ordered without auto shutoff it will stay on until the button is pressed or until the batteries are depleted. Turn gauge off when not in use to conserve battery.

Display backlighting on BBL models is on whenever the gauge is on. Backlighting is not apparent under bright conditions.

Operation – Ranges above 2000 including 3000 psi, 5000 psi

These ranges have a 4-digit display with a lower alphanumeric display. Press and hold the pushbutton for approximately 1 second. The full-scale range is indicated, display segments are tested, and the reading and units are displayed.

Power-Up With Zero – Ranges above 2000 including 3000 psi, 5000 psi

1. Make absolutely certain no pressure is applied to the gauge. The gauge port should be exposed to normal atmospheric pressure. Note that the zeroing function may only be activated at power-up and the stored zero correction is erased when the gauge is shut off.
2. Press and hold the pushbutton.
3. The full-scale range is indicated and the display segments are tested.
4. Continue to press the pushbutton until 0 0 0 0 is displayed and then release the button. This indicates that the gauge has been zeroed.
5. The actual pressure is displayed.

Attempting to zero the gauge with pressure greater than approximately 3% of full-scale applied will result in an error condition, and the display will alternately indicate *E r r 0* and the actual measured pressure. The gauge must be powered down to reset the error condition.

Absolute reference gauges do not use the zero feature since they read atmospheric pressure under normal conditions.

Normal Operation – Ranges 2000 and up including 3000 psi, 5000 psi

Following the start-up initialization, the display indicates the pressure reading updated approximately 3 times per second and the units. The auto shutoff timer starts when the gauge is powered up or whenever the button is pushed, unless the gauge was ordered without an auto shutoff time (-NS option).

If excessive vacuum is applied to a pressure-only gauge, the display will indicate *- E r r* until the vacuum is released. Applying vacuum to a gauge designed for pressure may damage the pressure sensor. If excessive pressure is applied (112.5% over range), an out-of-range indication of *! - - -* or *! - - - -* will be displayed depending on model.

Display Backlighting (BBL models only)

Display backlighting can be turned on by momentarily pressing the button whenever the gauge is on. The backlighting will turn on for one minute and then automatically shut off. This also restarts the auto shutoff timer. Backlighting is not apparent under bright conditions.

Shut-Down

To shut off the gauge manually at any time, press and hold the pushbutton until the display indicates 0 F F (about 5 seconds) and then release.

For gauges with auto shutoff, the display indicates 0 F F five seconds prior to auto shutoff. The pushbutton can be pressed to keep the gauge on. The auto shutoff and backlight (if equipped) timers are reset whenever the pushbutton is pressed and released.

If the gauge was ordered without auto shutoff, it will stay on until manually shut off or until the batteries are depleted. Turn gauge off when not in use to conserve battery life.

Battery Replacement

A low battery indication will be shown in the upper left-hand corner of the display when the battery voltage falls sufficiently. The battery should be replaced soon after the indicator comes on or unreliable readings may result.

Remove the 6 Phillips head screws on the back of the unit. Remove the battery holder or cover depending on the model.

Carefully remove batteries from the holders by lifting up the positive end of the battery (opposite the spring). Take care not to bend or distort the battery retention springs.

DO NOT discard the old battery into fire, any other sources of extreme heat, or in any other hazardous manner. Please consult local authorities if there is any question about proper disposal.

Always replace both batteries at the same time with high quality alkaline batteries. Observe the polarity of the batteries when replacing them. The negative (flat) end of each battery should be inserted first, and should face the spring in the battery holder.

Replace the back cover, including the rubber sealing gasket.

1000B, 1001B, 1000BBL

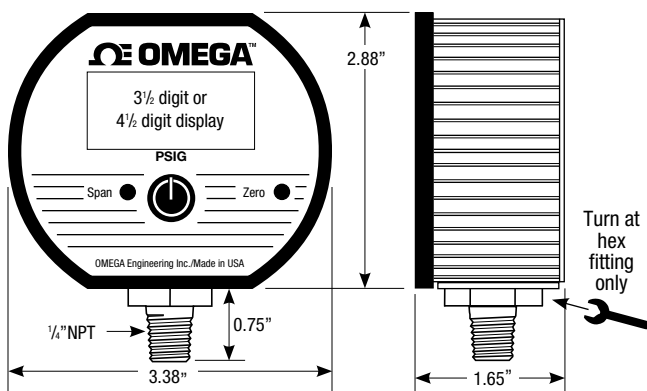

1100B and 1100BBL (NEMA 4X)

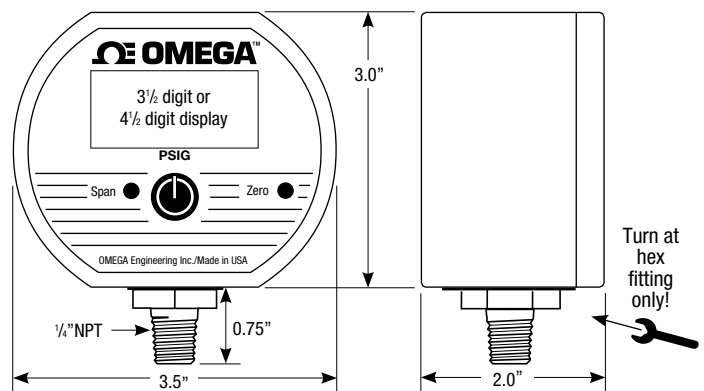

NOTE:**Calibration Information**

All gauges are factory calibrated on NIST traceable calibration equipment. No calibration is required before placing the gauge into service.

Gauges can be returned to Omega Engineering for factory certified recalibration. NIST traceability is available. Gauges can also be recalibrated by any metrology lab with pressure calibration equipment at least four times more accurate than the gauge.

Absolute reference models display atmospheric pressure if the gauge port is open to the ambient. It is normal for the reading to constantly change in response to atmospheric pressure changes. Vacuum generation and atmospheric pressure measurement equipment for accurate calibration and thus these are more difficult to calibrate in the field.

Calibration Preparation – All Models

All gauges are factory calibrated using NIST traceable calibration equipment. Calibration is not required before using the gauge. Calibration intervals depend on your quality standards, but annual re-calibration is customary.

Calibration equipment is not required to zero gauge reference ranges. Absolute reference ranges may be zeroed with application of full vacuum.

Span calibration should only be performed using appropriate calibration procedures with calibration standards that are at least four times more accurate than the gauge being calibrated.

The calibration system must be able to generate and measure pressure/vacuum over the full range of the gauge. A vacuum pump able to produce a vacuum of 100 microns (0.1 torr or 100 millitorr) or lower is required for vacuum and absolute gauges.

It is good practice to install fresh batteries before calibrating battery-powered gauges.

Allow the gauge to equalize to normal room temperature for approximately 20 minutes before calibration.

Calibration of Ranges up to 1999

DPG1000, DPG1001

DPG1100

For DPG1000AD and DPG1100AD models remove the front covers to access the zero and span calibration potentiometers.

For DPG1100AD models unscrew the nylon cover screws to access the zero and span calibration potentiometers.

Gauges may be re-zeroed without affecting the span calibration. For gauge reference models the gauge port must be open to the ambient. For absolute reference models full vacuum must be applied.

Adjust the zero control until the gauge reads zero with the minus (–) sign occasionally flashing.

Zero calibration must be done before span calibration.

Using the appropriate pressure standards, record readings at three to five points over the range of gauge and adjust span control to minimize error and meet specifications.

Calibration of Ranges 2000 and up including 3000 psi, 5000 psiDPG1000B, DPG1001B,
DPG1000BBL Ranges above 2000DPG1100B, DPG1100BBL
Ranges above 2000**Entering Calibration Mode**

Remove the rear cover to gain access to the UP and DOWN buttons located near the lower right and left corners of the circuit board.

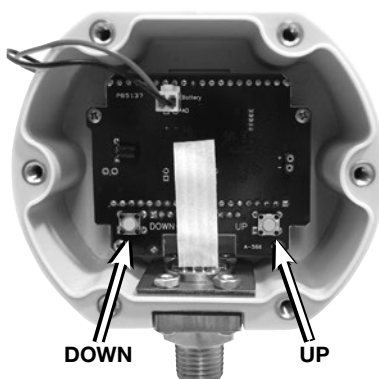

With the gauge off, press and hold the DOWN calibration button, and also press the front button.

The full-scale pressure range and display test is shown, and then CAL is displayed to indicate that the calibration mode is enabled.

Release all buttons. The gauge enters and remains in the calibration mode until restarted manually or power is removed. Features not related to calibration are disabled. If the power is removed during calibration, settings will not be saved.

The display will indicate the current pressure reading, updating approximately 3 times per second.

Each press of the UP or DOWN button makes a small correction, which may not always be indicated on the display. Press and hold the button for one second or longer to make larger corrections. The gauge's display is adjusted to match the calibrator's reading.

Gauge Reference Ranges (3 Points)

With the gauge port open to atmosphere, the character display will alternate between ZERO and CAL. Press the UP and DOWN buttons to obtain a display indication of zero.

Apply full-scale pressure (or vacuum for vacuum gauges). The character display will alternate between +SPAN and CAL. Press the UP and DOWN buttons to obtain a display indication equal to full-scale pressure.

Apply 50% of full-scale pressure. The character display will alternate between +MID and CAL. Use the UP and DOWN buttons to obtain a display indication equal to 50% of full-scale pressure.

Absolute Reference Ranges (3 Points)

Apply full vacuum to the gauge. The character display will alternate between ZERO and CAL. Press the UP and DOWN buttons to obtain a display indication of zero.

Apply full-scale pressure. The character display will alternate between +SPAN and CAL. Press the UP and DOWN buttons to obtain a display indication equal to full-scale pressure.

Apply 50% of full-scale pressure. The character display will alternate between +MID and CAL. Press the UP and DOWN buttons to obtain a display indication equal to 50% of full-scale pressure.

Bipolar (±) and Compound Ranges (4 or 5 Points)

With the gauge port open to atmosphere, the character display will alternate between ZERO and CAL. Press the UP and DOWN buttons to obtain a display indication of zero.

Apply full-scale positive pressure. The character display will alternate between +SPAN and CAL. Press the UP and DOWN buttons to obtain a display indication equal to full-scale pressure.

Apply 50% of full-scale positive pressure. The character display will alternate between +MID and CAL. Press the UP and DOWN buttons to obtain a display indication equal to 50% of full-scale pressure.

Apply full vacuum. The character display will alternate between –SPAN and CAL. Press the UP and DOWN buttons to obtain a display indication equal to the full vacuum reading.

Gauges using a ±15 psig sensor have a –MID calibration point. Apply 50% of the full-scale vacuum range (for example, –7.4 psi for a ±15 psi gauge). The character display will alternate between –MID and CAL. Press the UP and DOWN buttons to obtain a display indication equal to 50% of full-scale vacuum.

Exit Calibration Mode and Verify Calibration

Exit the calibration mode and save the calibration data by pressing and holding the front button until the display indicates OFF.

Verify readings at 0%, 25%, 50%, 75%, and 100% of full scale.

Replace the rear cover and screws, taking care not to pinch the wires between the case and the rear cover.

WARRANTY/DISCLAIMER

OMEGA ENGINEERING, INC. warrants this unit to be free of defects in materials and workmanship for a period of **13 months** from date of purchase. OMEGA's WARRANTY adds an additional one (1) month grace period to the normal **one (1) year product warranty** to cover handling and shipping time. This ensures that OMEGA's customers receive maximum coverage on each product.

If the unit malfunctions, it must be returned to the factory for evaluation. OMEGA's Customer Service Department will issue an Authorized Return (AR) number immediately upon phone or written request. Upon examination by OMEGA, if the unit is found to be defective, it will be repaired or replaced at no charge. OMEGA's WARRANTY does not apply to defects resulting from any action of the purchaser, including but not limited to mishandling, improper interfacing, operation outside of design limits, improper repair, or unauthorized modification. This WARRANTY is VOID if the unit shows evidence of having been tampered with or shows evidence of having been damaged as a result of excessive corrosion; or current, heat, moisture or vibration; improper specification; misapplication; misuse or other operating conditions outside of OMEGA's control. Components in which wear is not warranted, include but are not limited to contact points, fuses, and triacs.

OMEGA is pleased to offer suggestions on the use of its various products. However, OMEGA neither assumes responsibility for any omissions or errors nor assumes liability for any damages that result from the use of its products in accordance with information provided by OMEGA, either verbal or written. OMEGA warrants only that the parts manufactured by the company will be as specified and free of defects. OMEGA MAKES NO OTHER WARRANTIES OR REPRESENTATIONS OF ANY KIND WHATSOEVER, EXPRESSED OR IMPLIED, EXCEPT THAT OF TITLE, AND ALL IMPLIED WARRANTIES INCLUDING ANY WARRANTY OF MERCHANTABILITY AND FITNESS FOR A PARTICULAR PURPOSE ARE HEREBY DISCLAIMED. LIMITATION OF LIABILITY: The remedies of purchaser set forth herein are exclusive, and the total liability of OMEGA with respect to this order, whether based on contract, warranty, negligence, indemnification, strict liability or otherwise, shall not exceed the purchase price of the component upon which liability is based. In no event shall OMEGA be liable for consequential, incidental or special damages.

CONDITIONS: Equipment sold by OMEGA is not intended to be used, nor shall it be used: (1) as a "Basic Component" under 10 CFR 21 (NRC), used in or with any nuclear installation or activity; or (2) in medical applications or used on humans. Should any Product(s) be used in or with any nuclear installation or activity, medical application, used on humans, or misused in any way, OMEGA assumes no responsibility as set forth in our basic WARRANTY/DISCLAIMER language, and, additionally, purchaser will indemnify OMEGA and hold OMEGA harmless from any liability or damage whatsoever arising out of the use of the Product(s) in such a manner.

RETURN REQUESTS/INQUIRIES

Direct all warranty and repair requests/inquiries to the OMEGA Customer Service Department. BEFORE RETURNING ANY PRODUCT(S) TO OMEGA, PURCHASER MUST OBTAIN AN AUTHORIZED RETURN (AR) NUMBER FROM OMEGA'S CUSTOMER SERVICE DEPARTMENT (IN ORDER TO AVOID PROCESSING DELAYS). The assigned AR number should then be marked on the outside of the return package and on any correspondence.

The purchaser is responsible for shipping charges, freight, insurance and proper packaging to prevent breakage in transit.

FOR **WARRANTY** RETURNS, please have the following information available BEFORE contacting OMEGA:

1. Purchase Order number under which the product was PURCHASED,
2. Model and serial number of the product under warranty, and
3. Repair instructions and/or specific problems relative to the product.

FOR **NON-WARRANTY** REPAIRS, consult OMEGA for current repair charges. Have the following information available BEFORE contacting OMEGA:

1. Purchase Order number to cover the COST of the repair,
2. Model and serial number of the product, and
3. Repair instructions and/or specific problems relative to the product.

OMEGA's policy is to make running changes, not model changes, whenever an improvement is possible. This affords our customers the latest in technology and engineering.

OMEGA is a registered trademark of OMEGA ENGINEERING, INC.

© Copyright 2017 OMEGA ENGINEERING, INC. All rights reserved. This document may not be copied, photocopied, reproduced, translated, or reduced to any electronic medium or machine-readable form, in whole or in part, without the prior written consent of OMEGA ENGINEERING, INC.