

User's Guide



www.omega.com
e-mail: info@omega.com

PSW31 SERIES
ELECTRONIC PRESSURE SWITCH FOR PNEUMATIC APPLICATIONS



OMEGAnet® On-Line Service
www.omega.com

Internet e-mail
info@omega.com

Servicing North America:

USA:
ISO 9001 Certified

One Omega Drive, P.O. Box 4047
Stamford, CT 06907-0047
TEL: (203) 359-1660 FAX: (203) 359-7700
e-mail: info@omega.com

Canada:

976 Bergar
Laval (Quebec) H7L 5A1
TEL: (514) 856-6928 FAX: (514) 856-6886
e-mail: info@omega.ca

For immediate technical or application assistance:

USA and Canada:

Sales Service: 1-800-826-6342 / 1-800-TC-OMEGA®
Customer Service: 1-800-622-2378 / 1-800-622-BEST®
Engineering Service: 1-800-872-9436 / 1-800-USA-WHEN®
TELEX: 996404 EASYLINK: 62968934 CABLE: OMEGA

Mexico:

(001) 800-826-6342 FAX: (001) 203-359-7807
En Espanol: (001) 203-359-7803 e-mail: espanol@omega.com
Info@omega.com.mx

Servicing Europe:

Benelux:

Postbus 8034, 1180 LA Amstelveen, The Netherlands
TEL: +31 (0)20 6418405 FAX: +31 (0)20 6434643
Toll Free in Benelux: 0800 0993344
e-mail: nl@omega.com

Czech Republic:

Rudé armády 1868, 733 01 Karviná
TEL: +420 (0)69 6311899 FAX: +420 (0)69 6311114
Toll Free in Czech Rep.: 0800-1-66342 e-mail: czech@omega.com

France:

9, rue Denis Papin, 78190 Trappes
Tel: +33 (0)130 621 400 FAX: +33 (0)130 699 120
Toll Free in France: 0800-4-06342
e-mail: france@omega.com

Germany/Austria:

Daimlerstrasse 26, D-75392 Deckenpfronn, Germany
Tel: +49 (0)7056 3017 FAX: +49 (0)7056 8540
Toll Free in Germany: 0800-TC-OMEGA
e-mail: germany@omega.com

United Kingdom:
ISO 9002 Certified

One Omega Drive, River Bend Technology Centre
Northbank, Irlam, Manchester
M44 5EX, United Kingdom
Tel: +44 (0)161 777 6611 FAX: +44 (0)161 777 6622
Toll Free in the United Kingdom: 0800 488 488
e-mail: info@omega.co.uk

It is the policy of OMEGA to comply with all worldwide safety and EMC/EMI regulations that apply. OMEGA is constantly pursuing certification of its products to the European New Approach Directives. OMEGA will add the CE mark to every appropriate device upon certification.

The information contained in this document is believed to be correct, but OMEGA Engineering, Inc. accepts no liability for any errors it contains, and reserves the right to alter specifications without notice.

WARNING: These products are not designed for use in, and should not be used for, patient-connected applications.

PSW31 Series

APPLICATION

Ideal for Control of Filtered Compressed Air,
Lubricated or Non-Lubricated

FEATURES

- Real-Time LED Status Display of Pressure
- Adjustable Hysteresis
- Off-Line Calibration
- Fast, Accurate Response
- Extensive Service Life

SPECIFICATIONS

Ports/Mounting Plate	1/4" NPT
Adjustment Range	-14 to 350 PSI (-1 to 25 bar)
Maximum Pressure	See Part Number Identification Table
Temperature Rating	
Ambient	14° to 140° F (-10° to 60° C)
Media	14° to 175° F (-10° to 80° C)
Temperature Sensitivity	
@ Zero Point	Set Point Shifts 0.4% of FS/10°C
@ Set Point Pressure	Set Point Shifts 0.3% of FS/10°C
Electronics	Pressure Sensor, Microprocessor Evaluation Circuitry and Solid-state Output Driver
Switching/Reset Point	Adjustable between 0 – 100% of FS
Linearity	< 0.5% of Final Value ± 1 digit
Electrical Connector	DIN Style Plug with Removable Cable Plug Adapter

MATERIALS OF CONSTRUCTION

Housing	Die-Cast Zinc
----------------	---------------

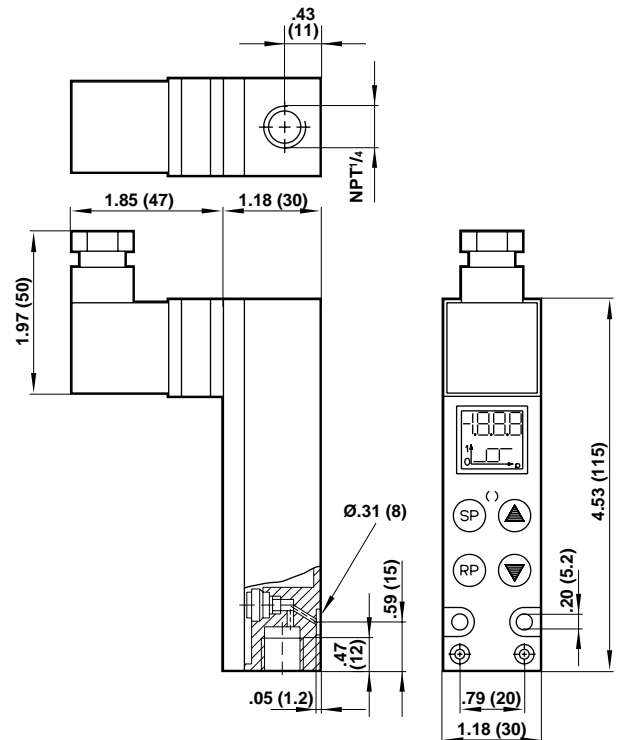

All dimensions in inches (mm)

ELECTRONIC PRESSURE SWITCH FOR PNEUMATIC APPLICATIONS

ELECTRICAL PARAMETERS

Electrical connection	DIN 43650 Table A
Power supply (polarity safe)	18 to 32V DC
Permissible residual ripple	10% (within 18 to 32V)
Current consumption	<50 mA (plus load current)

DIN 43650

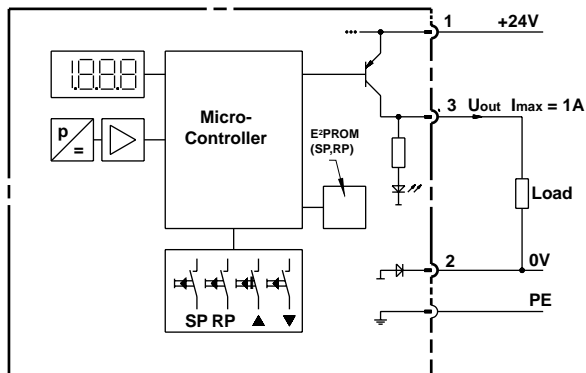

SWITCHING OUTPUT

Switching mode	Open collector PNP switched to supply (suited for inductive load)
Output voltage	Supply voltage minus 1.5V (approx)
Contact rating	$I_{max} = 1A$ (short-circuit proof)
Switching time	< 5ms
Service life	100 million switching cycles
Switching logic	Signal "on" with rising pressure, if SP* > RP** Signal "on" with falling pressure, if SP < RP

* SP = Switching point

**RP = Reset point

PART NUMBER IDENTIFICATION

PART NUMBER	SWITCHING PRESSURE RANGE - PSI	MAXIMUM PRESSURE	STEP SIZE OF DISPLAY*
PSW31B	-14 - 15	145	0.14
PSW31C	0 - 145	440	0.6 - 0.7
PSW31D	0 - 350	580	1 - 2

*Pressure display in PSI

ADJUSTING THE SWITCHING POINTS (SP) AND RESET POINTS (RP)

a) Adjusting the switching point.

Case 1

or Case 2

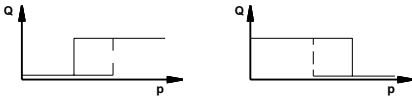

Press and hold the **SP** button. The display will show the previous switching pressure setting, and the dotted bar will flash while the button is pressed down (case 1).

You can now use the cursor keys to adjust the switching point upwards or downwards. If a cursor key is held down, the values will change faster. When the cursor key is released again, the switch-on pressure setting will cease to change. This setting is stored and activated when the **SP** button is released, after which the display will show the current pressure value and the bar will quit flashing.

b) Adjusting the reset point.

Case 3

or Case 4

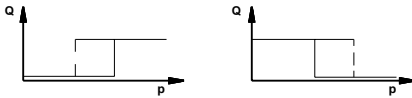

Press and hold the **RP** button. The display will show the previous reset pressure setting, and the dotted bar will flash while the button is pressed down.

You can now use the cursor keys to adjust the reset point in the same manner as described above.

During both adjustment operations, it may occur that the hysteresis graph changes from one state to another at the time a transition is made through the point "Switching pressure = Reset pressure". When both points are correctly set, the hysteresis graph will also be correct. You can change between **SP** and **RP** as often as you wish until the settings are correct.

c) Setting a buffering time.

In order to prevent brief pressure "spikes" or "surges" from causing undesired switching, a buffering time can be entered. The effect of this is that pressure changes are evaluated only if the pressure signal in question is present for longer than the buffering time. In order to set a buffering time, press the button **SP** before the power

supply is switched on. Release this button again after the power supply has been switched on. The display will then show the buffering time in milliseconds (e.g. 03) or seconds. The cursor buttons **▼**, **▲** can be used to set the buffering time to 03, 06, 12, 24 or 50 ms or 0.1, 0.2 or 0.4 seconds. When this has been done, press **SP** to store the setting.

d) Setting the pressure switch to ambient pressure = 0.

Since ambient pressure varies according to altitude, the user may re-calibrate the zero point to match local conditions.

Press the button **RP** before the power supply is switched on. Release this button again after the power supply has been switched on and the display test has run. The display will then show "OFS". The cursor buttons **▼**, **▲** can be used to set the pressure display to 0. When this has been done, press **SP** to store the setting.

e) Hysteresis mode

If it is desired to operate with a fixed hysteresis value instead of the reset point, this value can be selected as desired.

In order to set a hysteresis value, the two buttons **SP** and **▼** must be pressed simultaneously before the power supply is switched on.

Release these buttons again after the power supply has been switched on and the display test has run. The display will then show the operating mode. The cursor buttons **▲**, **▼** can now be used to change the operating mode until "HYS" appears in the display. When this has been done, press **SP** to store the setting.

The **SP** button can be used to display the switching-point setting, which can be modified by means of the cursor buttons **▲**, **▼**.

The button **RP** can be used to display the hysteresis setting, which can also be modified by means of the cursor buttons **▲**, **▼**.

Negative hysteresis means: Signal "on" with rising pressure (case 1).

Positive hysteresis means: Signal "on" with falling pressure (case 2).

If the switching point is modified, this will automatically also result in a change in the reset point by a value equal to the hysteresis setting.

Case 1

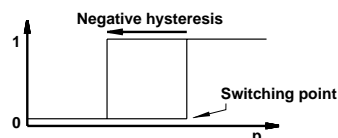

Case 2

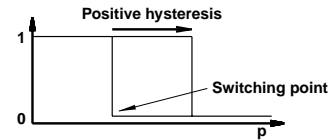

f) Window mode

If it is desired to monitor whether the pressure lies within a certain range, a switching window can be created for this purpose. The pressure switch will then indicate cases in which the actual pressure lies above or below this area. In order to set a switching window, the two buttons **SP** and **▼** must be pressed simultaneously before the power supply is switched on.

Release these buttons again after the power supply has been switched on and the display test has run. The display will then show the operating mode.

The cursor buttons **▲**, **▼** can now be used to change the operating mode until "FEn" (standing for "Window") in the display. When this has been done, press **SP** to store the setting. The button **SP** can be used to display the switching-point setting, which can be modified by means of the cursor buttons **▼**, **▲**.

The distance between the switching point and reset point is the switching window. If the switching point is lower than the reset point, a signal will be output as long as the pressure lies within the preset window (case 1, rising pressure). If the switching point is higher than the reset point, a signal will be output as long as the pressure lies outside the preset window (case 2, rising pressure). In the case of falling pressure, the signal is inverted.

Case 1

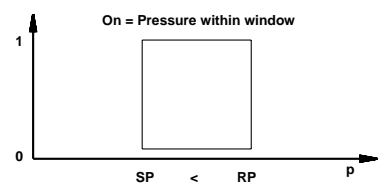

Case 2

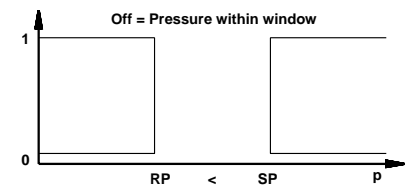

Std = Standard mode, switching and reset points adjustable
 HYS = Hysteresis mode, switching point and hysteresis adjustable
 FEn = Window mode, switching window adjustable

Switching Characteristic Graphs

Signal "on" with rising pressure
Setting $SP^* > RP^{**}$

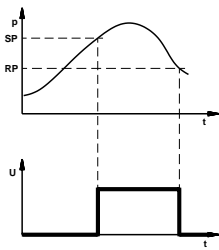

Signal "on" with falling pressure
Setting $SP < RP$

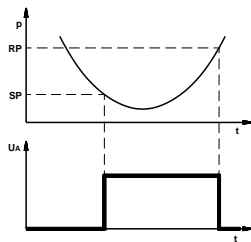

Signal "off" with rising pressure
Setting $RP > SP$

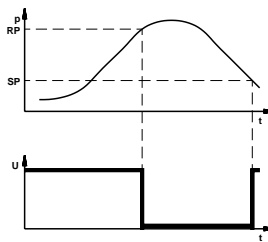

Signal "off" with falling pressure
Setting $RP < SP$

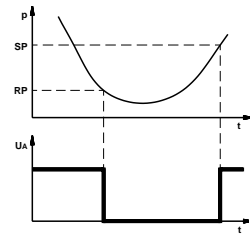

* SP = Switching point
**RP = Reset point

Explanation:

When the switching point (SP) is adjusted **HIGHER** than the reset point (RP), then the switching output will be "normally off".
When the switching point (SP) is adjusted **LOWER** than the reset point (RP), then the switching output will be "normally on".

Position of operating elements

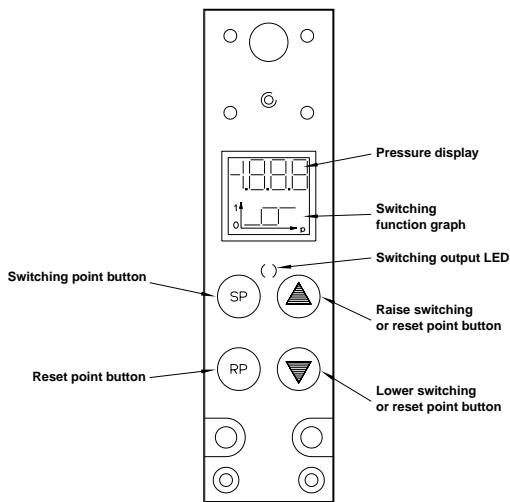

ERROR MESSAGES

Display of hardware errors or malfunctions

Display	Meaning	Cause / Remedy
O.Er	Output error	Error at switching output: Circuit-breaker defective, feedback loop to processor open circuit. Repair necessary.
E.Er	E ² PROM error	E ² PROM module defective or connection to processor faulty. Repair necessary.
I.Er	Initialization error	Checksum of initialization data incorrect. Remedy: Call up any SETUP function and acknowledge the setting with SP. This error message is caused by a data error. All setup values should therefore be checked and corrected if necessary.
C.Er	Calibration error	Checksum of calibration data incorrect. Recalibration necessary.
SC.L	Short-circuit low	Short-circuit between output and ground. Check wiring: Power supply may be too weak for connected load (leading to collapse of voltage, particularly with loads with a high switch-on current such as incandescent lamps or capacitances).
UFL	Underflow	The applied pressure is below the measuring range: Increase pressure until it is within the measuring range.
OFL	Overflow	The applied pressure is above the measuring range: Decrease pressure until it is within the measuring range.

Display of hardware errors or malfunctions (can be switched off)

Display	Meaning	Cause / Remedy
SC.H	Short-circuit high	Short-circuit between output and power supply. Check wiring. If the switching line from the load (e.g. electrical control device, PLC or similar) is being held at an open-circuit potential of > 3V, or if several pressure switches are being operated in parallel, this function should be switched off. Disconnection: ▼ during display test, then adjust with ▼ or ▲.
U.Lo	Voltage low	Power supply voltage too low (<17V). Check power supply: Load may be too large. Disconnection: ▲ during display test, then adjust with ▼ or ▲.

Messages generated by calling SETUP functions

Cod	Meaning	Requested code or code programming
CLC	Clear code	Deletion of current code
txx	Delay time (Buffering time)	Setting of filter time constant
		xx = Switching output delay
		xx ∈ {03, 06, 12, 24, 50} in ms and xx ∈ {0.1, 0.2, 0.4} in s.
OFS	Offset	Request for offset adjustment using ▼ and ▲ buttons
SC.H	Short-circuit high	Short-circuit monitoring activated
U. LO	Voltage low	Voltage monitoring activated
OFF	Off	Short-circuit or voltage monitoring deactivated
Std	Standard mode	Standard mode activated
HYS	Hysteresis mode	Hysteresis mode activated
FEn	Window mode	Window mode activated
U-C	Voltage calibration	Voltage output selected
I-C	Current calibration	Current output selected

WARRANTY/DISCLAIMER

OMEGA ENGINEERING, INC. warrants this unit to be free of defects in materials and workmanship for a period of 13 months from date of purchase. OMEGA's Warranty adds an additional one (1) month grace period to the normal one (1) year product warranty to cover handling and shipping time. This ensures that OMEGA's customers receive maximum coverage on each product.

If the unit malfunctions, it must be returned to the factory for evaluation. OMEGA's Customer Service Department will issue an Authorized Return (AR) number immediately upon phone or written request. Upon examination by OMEGA, if the unit is found to be defective, it will be repaired or replaced at no charge. OMEGA's WARRANTY does not apply to defects resulting from any action of the purchaser, including but not limited to mishandling, improper interfacing, operation outside of design limits, improper repair, or unauthorized modification. This WARRANTY is VOID if the unit shows evidence of having been tampered with or shows evidence of having been damaged as a result of excessive corrosion; or current, heat, moisture or vibration; improper specification; mis-application; misuse or other operating conditions outside of OMEGA's control. Components, which wear, are not warranted, including but not limited to contact points, fuses, and triacs.

OMEGA is pleased to offer suggestions on the use of its various products. However, OMEGA neither assumes responsibility for any omissions or errors nor assumes liability for any damages that result from the use of its products in accordance with information provided by OMEGA, either verbal or written. OMEGA warrants only that the parts manufactured by it will be as specified and free of defects. OMEGA MAKES NO OTHER WARRANTIES OR REPRESENTATIONS OF ANY KIND WHATSOEVER, EXPRESS OR IMPLIED, EXCEPT THAT OF TITLE, AND ALL IMPLIED WARRANTIES INCLUDING ANY WARRANTY OF MERCHANTABILITY AND FITNESS FOR A PARTICULAR PURPOSE ARE HEREBY DISCLAIMED. LIMITATION OF LIABILITY: The remedies of purchaser set forth herein are exclusive, and the total liability of OMEGA with respect to this order, whether based on contract, warranty, negligence, indemnification, strict liability or otherwise, shall not exceed the purchase price of the component upon which liability is based. In no event shall OMEGA be liable for consequential, incidental or special damages.

CONDITIONS: Equipment sold by OMEGA is not intended to be used, nor shall it be used: (1) as a "Basic Component" under 10 CFR 21 (NRC), used in or with any nuclear installation or activity; or (2) in medical applications or used on humans. Should any Product(s) be used in or with any nuclear installation or activity, medical application, used on humans, or misused in any way, OMEGA assumes no responsibility as set forth in our basic WARRANTY / DISCLAIMER language, and, additionally, purchaser will indemnify OMEGA and hold OMEGA harmless from any liability or damage whatsoever arising out of the use of the Product(s) in such a manner.

RETURN REQUESTS / INQUIRIES

Direct all warranty and repair requests/inquiries to the OMEGA Customer Service Department. BEFORE RETURNING ANY PRODUCT(S) TO OMEGA, PURCHASER MUST OBTAIN AN AUTHORIZED RETURN (AR) NUMBER FROM OMEGA'S CUSTOMER SERVICE DEPARTMENT (IN ORDER TO AVOID PROCESSING DELAYS). The assigned AR number should then be marked on the outside of the return package and on any correspondence.

The purchaser is responsible for shipping charges, freight, insurance and proper packaging to prevent breakage in transit.

FOR WARRANTY RETURNS, please have the following information available BEFORE contacting OMEGA:

1. Purchase Order number under which the product was PURCHASED,
2. Model and serial number of the product under warranty, and
3. Repair instructions and/or specific problems relative to the product.

FOR NON-WARRANTY REPAIRS, consult OMEGA for current repair charges. Have the following information available BEFORE contacting OMEGA.

1. Purchase Order number to cover the COST of the repair,
2. Model and serial number of the product, and
3. Repair instructions and/or specific problems relative to the product.

OMEGA's policy is to make running changes, not model changes, whenever an improvement is possible.

This affords our customers the latest in technology and engineering.

OMEGA is a registered trademark of OMEGA ENGINEERING, INC.

©Copyright 1999 OMEGA ENGINEERING, INC. All rights reserved. This document may not be copied, photocopied, reproduced, translated, or reduced to any electronic medium or machine-readable form, in whole or in part, without the prior written consent of OMEGA ENGINEERING, INC.

Where Do I Find Everything I Need for Process Measurement and Control? OMEGA...Of Course!

TEMPERATURE

- Thermocouple, RTD & Thermistor Probes, Connectors, Panels & Assemblies
- Wire: Thermocouple, RTD & Thermistor
- Calibrators & Ice Point References
- Recorders, Controllers & Process Monitors
- Infrared Pyrometers

PRESSURE, STRAIN AND FORCE

- Transducers & Strain Gages
- Load Cells & Pressure Gages
- Displacement Transducers
- Instrumentation & Accessories

FLOW/LEVEL

- Rotameters, Gas Mass Flow Meters & Flow Computers
- Air Velocity Indicators
- Turbine/Paddlewheel Systems
- Totalizers & Batch Controllers

pH/CONDUCTIVITY

- pH Electrodes, Testers & Accessories
- Benchtop/Laboratory Meters
- Controllers, Calibrators, Simulators & Pumps
- Industrial pH & Conductivity Equipment

DATA ACQUISITION

- Data Acquisition & Engineering Software
- Communications-Based Acquisition Systems
- Plug-in Cards for Apple, IBM & Compatibles
- Datalogging Systems
- Recorders, Printers & Plotters

HEATERS

- Heating Cable
- Cartridge & Strip Heaters
- Immersion & Band Heaters
- Flexible Heaters
- Laboratory Heaters

ENVIRONMENTAL MONITORING AND CONTROL

- Metering & Control Instrumentation
- Refractometers
- Pumps & Tubing
- Air, Soil & Water Monitors
- Industrial Water & Wastewater Treatment
- pH, Conductivity & Dissolved Oxygen Instruments