

CE

YEAR  
2000  
COMPLIANT



# User's Guide

**omega.com**<sup>®</sup>

Ω OMEGA<sup>®</sup>

<http://www.omega.com>  
e-mail: [info@omega.com](mailto:info@omega.com)

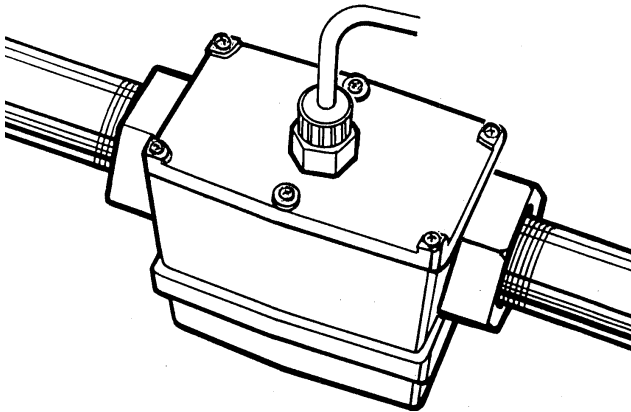

## **FLSC790-P** **Pulse Output Module** For use with FTB790 Series Turbine Meters with Display Electronics



OMEGAnet® On-Line Service <a href="http://www.omega.com">http://www.omega.com</a>	Internet e-mail <a href="mailto:info@omega.com">info@omega.com</a>
--	---

**Servicing North America:**

**USA:**  
ISO 9001 Certified

One Omega Drive, Box 4047  
Stamford, CT 06907-0047  
Tel: (203) 359-1660  
e-mail: [info@omega.com](mailto:info@omega.com)  
FAX: (203) 359-7700

**Canada:**

976 Bergar  
Laval (Quebec) H7L 5A1  
Tel: (514) 856-6928  
e-mail: [info@omega.ca](mailto:info@omega.ca)  
FAX: (514) 856-6886

**For immediate technical or application assistance:**

**USA and Canada:**

Sales Service: 1-800-826-6342 / 1-800-TC-OMEGA<sup>SM</sup>  
Customer Service: 1-800-622-2378 / 1-800-622-BEST<sup>SM</sup>  
Engineering Service: 1-800-872-9436 / 1-800-USA-WHEN<sup>SM</sup>  
TELEX: 996404 EASYLINK: 62968934 CABLE: OMEGA

**Mexico and Latin America:**

Tel: (001) 800-826-6342  
En Español: (001) 203-359-7803  
FAX: (001) 203-359-7807  
e-mail: [espanol@omega.com](mailto:espanol@omega.com)

**Servicing Europe:**

**Benelux:**

Postbus 8034, 1180 LA Amstelveen, The Netherlands  
Tel: (31) 20 6418405  
Toll Free in Benelux: 0800 0993344  
e-mail: [nl@omega.com](mailto:nl@omega.com)  
FAX: (31) 20 6434643

**Czech Republic:**

ul. Rude armady 1868, 733 01 Karvina-Hranice  
Tel: 420 (69) 6311899  
Toll Free: 0800-1-66342  
e-mail: [czech@omega.com](mailto:czech@omega.com)  
FAX: 420 (69) 6311114

**France:**

9, rue Denis Papin, 78190 Trappes  
Tel: (33) 130-621-400  
Toll Free in France: 0800-4-06342  
e-mail: [france@omega.com](mailto:france@omega.com)  
FAX: (33) 130-699-120

**Germany/Austria:**

Daimlerstrasse 26, D-75392 Deckenpfronn, Germany  
Tel: 49 (07056) 3017  
Toll Free in Germany: 0130 11 21 66  
e-mail: [info@omega.de](mailto:info@omega.de)  
FAX: 49 (07056) 8540

**United Kingdom:**

ISO 9002 Certified

One Omega Drive, River Bend Technology Centre  
Northbank, Irlam, Manchester  
M44 5EX, United Kingdom  
Tel: 44 (0161) 777-6611  
Toll Free in United Kingdom: 0800-488-488  
e-mail: [info@omega.co.uk](mailto:info@omega.co.uk)  
FAX: 44 (0161) 777-6622

It is the policy of OMEGA to comply with all worldwide safety and EMC/EMI regulations that apply. OMEGA is constantly pursuing certification of its products to the European New Approach Directives. OMEGA will add the CE mark to every appropriate device upon certification.

The information contained in this document is believed to be correct, but OMEGA Engineering, Inc. accepts no liability for any errors it contains, and reserves the right to alter specifications without notice.

**WARNING:** These products are not designed for use in, and should not be used for, patient-connected applications.

## TABLE OF CONTENTS

Introduction .....	1
Installation and Wiring .....	1
Technical Specifications .....	2
Typical Wiring .....	3
Warranty/Disclaimer .....	5
Return Requests/Inquiries .....	5

## INTRODUCTION

**Caution: This Pulse Output Module is not FM Approved. Therefore, use of this module with an approved metering system, voids FM Approval.**

This module is designed to be used only with FTB790 Series Turbine Meters. More specifically, turbine housings with the following models: FTB791, FTB792, FTB793, FTB794, and FTB795.

Combine the Pulse Access Module with an FTB790 Series Turbine Electronics to create a low-cost flow sensor with both local read-out and pulse output which interfaces with various counters, controllers, and compatible process equipment.

The pulse output of this module provides an unscaled, amplified, digital signal capable of transmission up to 5,000 ft. (1,524m) without additional signal conditioning or amplification devices.

The Pulse Output Module comes complete, ready to install, with a circuit assembly, coverplate assembly, and 10 ft. (3m) of cable.

## INSTALLATION & WIRING

To install this module, follow the instructions given below.

1. Remove the back coverplate from the turbine housing.
2. Remove the display electronics from the front of the turbine.

**NOTE:** If you are installing more than one Pulse Access Module at a time, take care to keep the proper electronics paired with the original turbine.

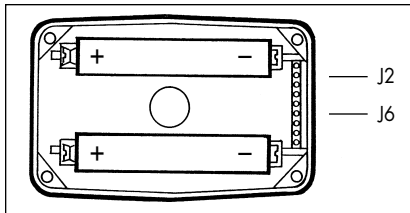

3. The Pulse Access Module connects to a 10-pin connector located on the back side of the computer electronics next to the negative battery connectors. The 10-pin connector is sealed with a clear plastic sealant that must be carefully pried out with a small sharp tool inserted gently at the edges.
4. Remove the backing from the double-sided tape on the module's PC board.
5. Carefully align the top pin on the PC board with the J2 position on the 10-pin connector and gently press the PC board into position between the batteries. The bottom pin will align with the J6 position.
6. Guide the loose ends of the wires from the PC board through the housing's cavity to the back side of the turbine.
7. Install the display electronics to the front side of the turbine and tighten the four screws snugly.

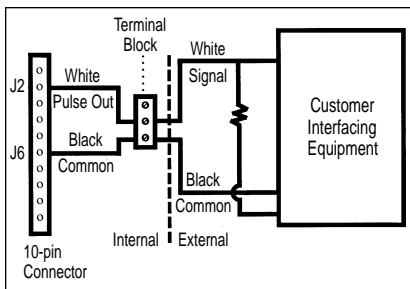

8. Connect the loose ends of the wires to the terminal block on the inside of the back coverplate provided with this module. Connect white (pulse out) to white and black (common) to black.

**Caution:** Do not connect the red wire. This module does not require connection of the red wire. Use of this wire will damage your equipment.

9. Install the back coverplate. Make sure the O-ring is securely seated and no wires are pinched.
10. Connect to the user interface device according to manufacturer's instructions.
11. Refer to the etched K-factor on the turbine. See Turbine Manual for location of K-factor.

**NOTE:** Please remember to supply a 820 ohm (minimum) Pull Up Resistor if the interface device does not have one. Reference illustration above as necessary.

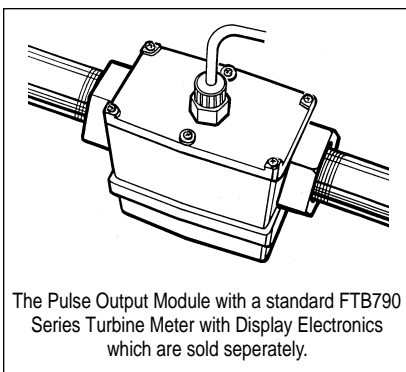

The Pulse Output Module with a standard FTB790 Series Turbine Meter with Display Electronics which are sold separately.

## TECHNICAL SPECIFICATIONS

Frequency Range: 0 to 750 Hz  
 Housing Material: Nylon 6/6  
 Strain Relief: Hubble-PG7  
 Coverplate Thread: Female 1/2-20 UNF-2B  
 Cable: Belden 9363  
 Std. Cable Length: 10 ft. (3m)  
 Temperature: +14° to +140°F  
 (-10° to +60°C)

### Open Collector Current Sinking Output

Applied Voltage: 0 to 60 Volts DC  
 Connection: Two Wire  
 Allowable Current: Up to 100 mA  
 Output: Square Wave Pulse.  
 Amplitude same as supplied voltage.

**NOTE:** Display electronics, which work in conjunction with this module, continue to be powered with batteries.

## Dimensions (FLSC790-P)

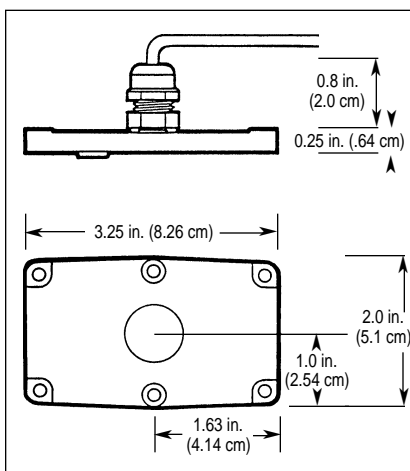

# TYPICAL WIRING

## Wiring to DPF700 Series Panel Meter

For connecting to the DPF700 meter, attach the white wire to Pin 2 on TB2, "SIG IN". The black wire goes to Pin 3 on TB2, "SIG GND". Set the S1 switches for 12.4 VDC OUT. No connection is made to "EXCITATION OUT"; the white wire is pulled up to the 12.4 VDC excitation inside of the DPF700.

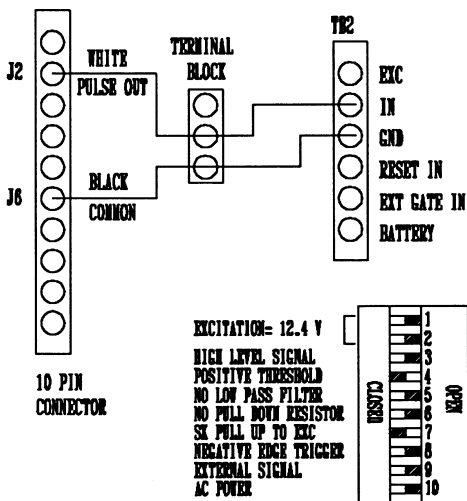

## Wiring to DPF70 Series Panel Meter (DPF75, DPF76, DPF78)

For connecting to DPF70 Series panel meter, connect white wire to Pin 5 (A input), the black wire to Pin 8 (DC Ground), and connect a 820 ohm (minimum) pull up resistor between Pin 5 and Pin 7 (DC Excitation)

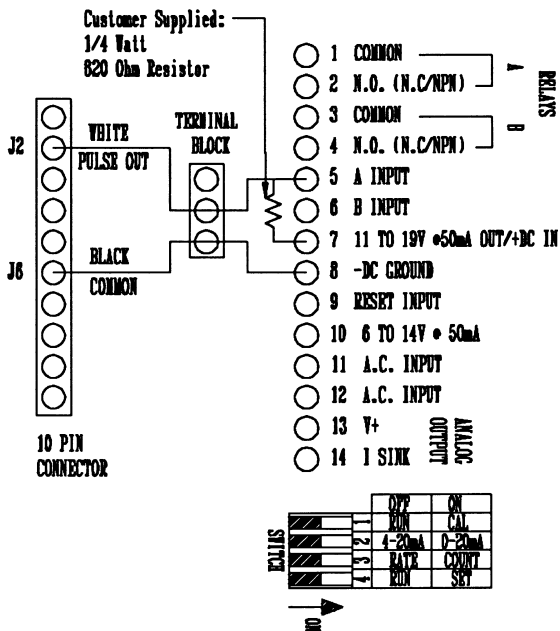

## NOTES



## WARRANTY / DISCLAIMER

OMEGA ENGINEERING, INC. warrants this unit to be free of defects in materials and workmanship for a period of **13 months** from date of purchase. OMEGA Warranty adds an additional one (1) month grace period to the normal **one (1) year product warranty** to cover handling and shipping time. This ensures that OMEGA's customers receive maximum coverage on each product.

If the unit malfunctions, it must be returned to the factory for evaluation. OMEGA's Customer Service Department will issue an Authorized Return (AR) number immediately upon phone or written request. Upon examination by OMEGA, if the unit is found to be defective, it will be repaired or replaced at no charge. OMEGA's WARRANTY does not apply to defects resulting from any action of the purchaser, including but not limited to mishandling, improper interfacing, operation outside of design limits, improper repair, or unauthorized modification. This WARRANTY is VOID if the unit shows evidence of having been tampered with or shows evidence of having been damaged as a result of excessive corrosion; or current, heat, moisture or vibration; improper specification; misapplication; misuse or other operating conditions outside of OMEGA's control. Components which wear are not warranted, including but not limited to contact points, fuses, and triacs.

**OMEGA is pleased to offer suggestions on the use of its various products. However, OMEGA neither assumes responsibility for any omissions or errors nor assumes liability for any damages that result from the use of its products in accordance with information provided by OMEGA, either verbal or written. OMEGA warrants only that the parts manufactured by it will be as specified and free of defects. OMEGA MAKES NO OTHER WARRANTIES OR REPRESENTATIONS OF ANY KIND WHATSOEVER, EXPRESS OR IMPLIED, EXCEPT THAT OF TITLE, AND ALL IMPLIED WARRANTIES INCLUDING ANY WARRANTY OF MERCHANTABILITY AND FITNESS FOR A PARTICULAR PURPOSE ARE HEREBY DISCLAIMED. LIMITATION OF LIABILITY:** The remedies of purchaser set forth herein are exclusive, and the total liability of OMEGA with respect to this order, whether based on contract, warranty, negligence, indemnification, strict liability or otherwise, shall not exceed the purchase price of the component upon which liability is based. In no event shall OMEGA be liable for consequential, incidental or special damages.

CONDITIONS: Equipment sold by OMEGA is not intended to be used, nor shall it be used: (1) as a "Basic Component" under 10 CFR 21 (NRC), used in or with any nuclear installation or activity; or (2) in medical applications or used on humans. Should any Product(s) be used in or with any nuclear installation or activity, medical application, used on humans, or misused in any way, OMEGA assumes no responsibility as set forth in our basic WARRANTY/DISCLAIMER language, and, additionally, purchaser will indemnify OMEGA and hold OMEGA harmless from any liability or damage whatsoever arising out of the use of the Product(s) in such a manner.

## RETURN REQUESTS / INQUIRIES

Direct all warranty and repair requests/inquiries to the OMEGA Customer Service Department. BEFORE RETURNING ANY PRODUCT(S) TO OMEGA, PURCHASER MUST OBTAIN AN AUTHORIZED RETURN (AR) NUMBER FROM OMEGA'S CUSTOMER SERVICE DEPARTMENT (IN ORDER TO AVOID PROCESSING DELAYS). The assigned AR number should then be marked on the outside of the return package and on any correspondence. The purchaser is responsible for shipping charges, freight, insurance and proper packaging to prevent breakage in transit.

FOR **WARRANTY** RETURNS, please have the following information available BEFORE contacting OMEGA:

1. Purchase Order number under which the product was PURCHASED,
2. Model and serial number of the product under warranty, and
3. Repair instructions and/or specific problems relative to the product.

FOR **NON-WARRANTY** RETURNS, consult OMEGA for current repair charges. Have the following information available BEFORE contacting OMEGA:

1. Purchase Order number to cover the COST of the repair,
2. Model and serial number of the product, and
3. Repair instructions and/or specific problems relative to the product.

OMEGA's policy is to make running changes, not model changes, whenever an improvement is possible. This affords our customers the latest in technology and engineering.

OMEGA is a registered trademark of OMEGA ENGINEERING, INC.

© Copyright 1998 OMEGA ENGINEERING, INC. All rights reserved. This document may not be copied, photocopied, reproduced, translated, or reduced to any electronic medium or machine-readable form, in whole or in part, without the prior written consent of OMEGA ENGINEERING, INC.

# Where Do I Find Everything I Need for Process Measurement and Control? OMEGA... Of Course!

## TEMPERATURE

- Thermocouple, RTD & Thermistor Probes, Connectors, Panels & Assemblies
- Wire: Thermocouple, RTD & Thermistor
- Calibrators & Ice Point References
- Recorders, Controllers & Process Monitors
- Infrared Pyrometers

## PRESSURE, STRAIN AND FORCE

- Transducers & Strain Gauges
- Load Cells & Pressure Gauges
- Displacement Transducers
- Instrumentation & Accessories

## FLOW/LEVEL

- Rotameters, Gas Mass Flowmeters & Flow Computers
- Air Velocity Indicators
- Turbine/Paddlewheel Systems
- Totalizers & Batch Controllers

## pH/CONDUCTIVITY

- pH Electrodes, Testers & Accessories
- Benchtop/Laboratory Meters
- Controllers, Calibrators, Simulators & Pumps
- Industrial pH & Conductivity Equipment

## DATA ACQUISITION

- Data Acquisition & Engineering Software
- Communications-Based Acquisition Systems
- Plug-in Cards for Apple, IBM & Compatibles
- Datalogging Systems
- Recorders, Printers & Plotters

## HEATERS

- Heating Cable
- Cartridge & Strip Heaters
- Immersion & Band Heaters
- Flexible Heaters
- Laboratory Heaters

## ENVIRONMENTAL MONITORING AND CONTROL

- Metering & Control Instrumentation
- Refractometers
- Pumps & Tubing
- Air, Soil & Water Monitors
- Industrial Water & Wastewater Treatment
- pH, Conductivity & Dissolved Oxygen Instruments