

# MODELS CN2208 and CN2204 TEMPERATURE CONTROLLERS

## INSTALLATION AND OPERATION HANDBOOK

<b>Contents</b>	<b>Page</b>
<b>Chapter 1</b>	<b>OPERATION..... 1-1</b>
<b>Chapter 2</b>	<b>INSTALLATION..... 2-1</b>
<b>Chapter 3</b>	<b>ACCESS LEVELS ..... 3-1</b>
<b>Chapter 4</b>	<b>TUNING ..... 4-1</b>
<b>Chapter 5</b>	<b>CONFIGURATION..... 5-1</b>
<b>Chapter 6</b>	<b>USER CALIBRATION ..... 6-1</b>
<b>Chapter 7</b>	<b>ALARM CONFIGURATION..... 7-1</b>
<b>Appendix A</b>	<b>UNDERSTANDING THE ORDERING ..... A-1</b>
<b>Appendix B</b>	<b>SAFETY &amp; EMC INFORMATION ..... B-1</b>
	<b>TECHNICAL SPECIFICATION ..... B-5</b>



---

# Chapter 1 OPERATION

<b>CONTENTS</b>	<b>PAGE</b>
<b>Front Panel Layouts .....</b>	<b>1-2</b>
<b>Getting Started .....</b>	<b>1-4</b>
<b>Navigation Diagram .....</b>	<b>1-10</b>
<b>Parameter Tables .....</b>	<b>1-12</b>
<b>Setting Alarm Levels .....</b>	<b>1-17</b>
<b>Diagnostic Alarms .....</b>	<b>1-18</b>

### FRONT PANEL LAYOUT

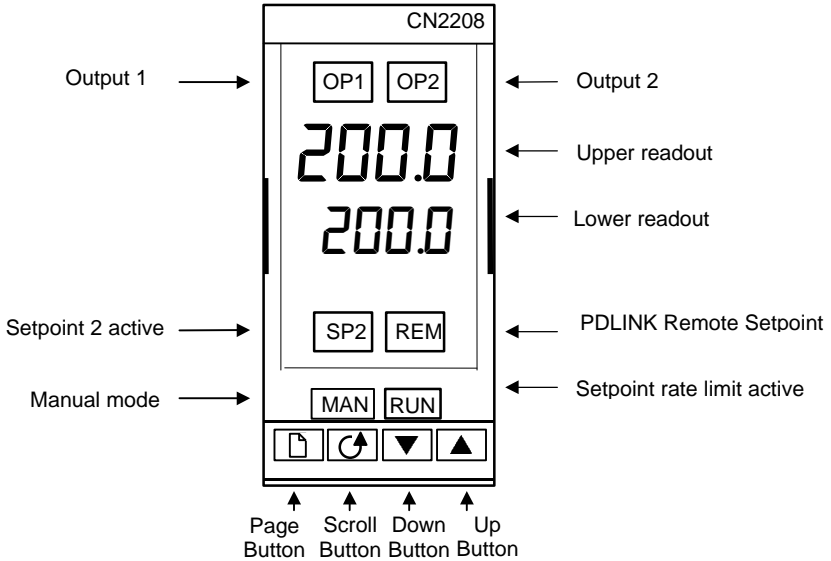

Fig 1-1 Model CN2208 front panel layout

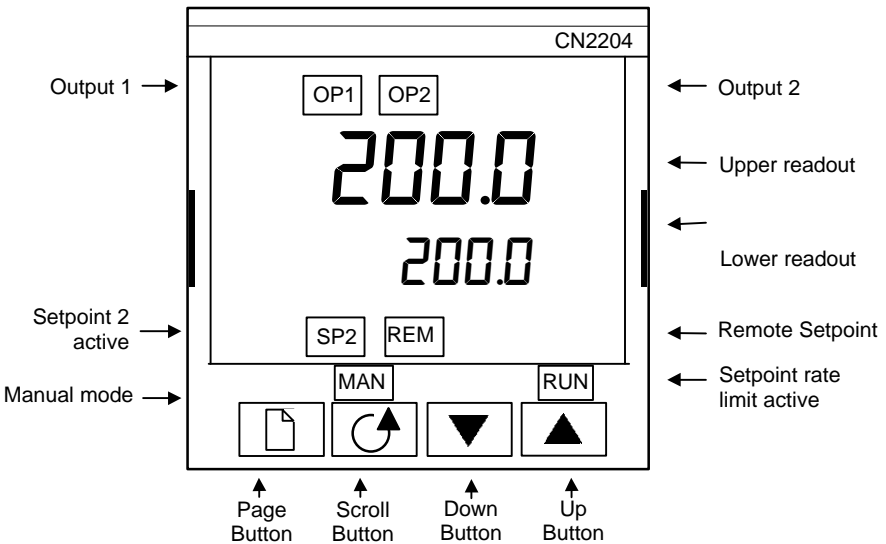





Fig 1-2 Model CN2204 front panel layout

Button or indicator	Name	Explanation
OP1	Output 1	When lit, it indicates that output 1 is on. This is normally the heating output.
OP2	Output 2	When lit, it indicates that output 2 is on. This is normally the cooling output.
SP2	Setpoint 2	When lit, this indicates that Setpoint 2 has been selected.
REM	Remote Setpoint	When lit, this indicates that the PDLINK remote Setpoint input has been selected. 'REM' is also used to indicate that user comms is active.
MAN	Manual light	When lit, it indicates that manual mode has been selected
RUN	Run light	When lit, it indicates that Setpoint rate limit is active.
	Page button	Press to select a new list of parameters.
	Scroll button	Press to select a new parameter in a list.
	Down button	Press to decrease a value in the lower readout.
	Up button	Press to increase a value in lower readout.

**Figure 1.3 Controller buttons and indicators**

## GETTING STARTED

Thank you for selecting the OMEGA CN2208/CN2204 controller.  
 This section shows the **principle** of operation.

### VIEWING THE PROCESS VALUE and SETPOINT

**Install and wire up** the controller in accordance with Chapter 2 and switch on.  
 Following a 3-second self-test sequence, this is the display you will see:

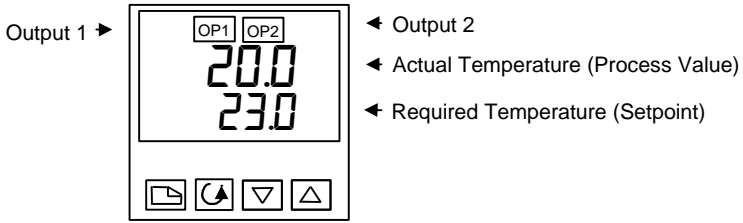

**Fig. 1.4 The “Home Display”**

**NOTE**



The display may flash an alarm message. Refer to the Parameter Tables later in this chapter for a complete list and meaning of the messages.

### TO ADJUST THE SETPOINT

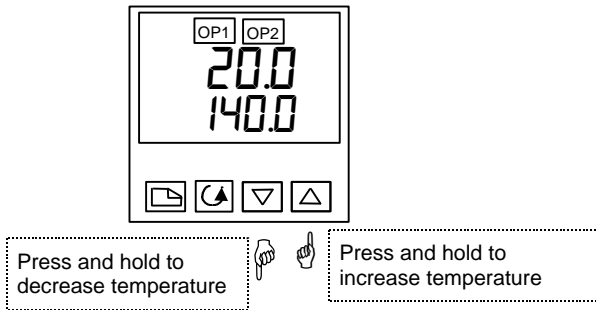

**Fig 1.5 The lower readout shows the setpoint**

After 2 secs the lower readout will ‘blink’ indicating that the new value has been accepted. For everyday use you may not need to do anymore than this.

## VIEWING THE DISPLAY UNITS

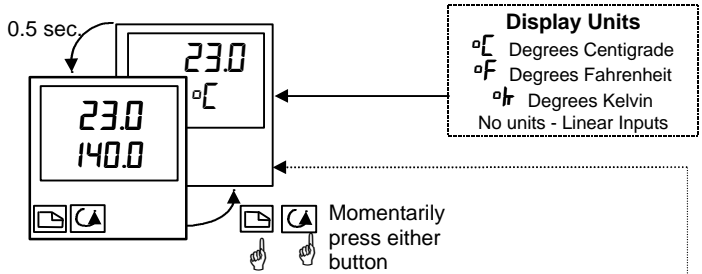

**NOTE**



If you get lost, pressing and together will return you to the Home display

Fig. 1.6 Pressing or will flash the display units for 0.05 sec.

### USE OF THE “SCROLL” BUTTON

Pressing the scroll button will display the output power level. Continued pressing will display further parameters in what is referred to as the operator scroll list.

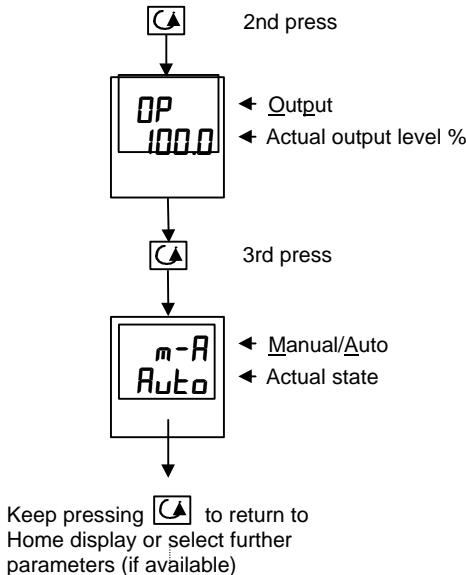

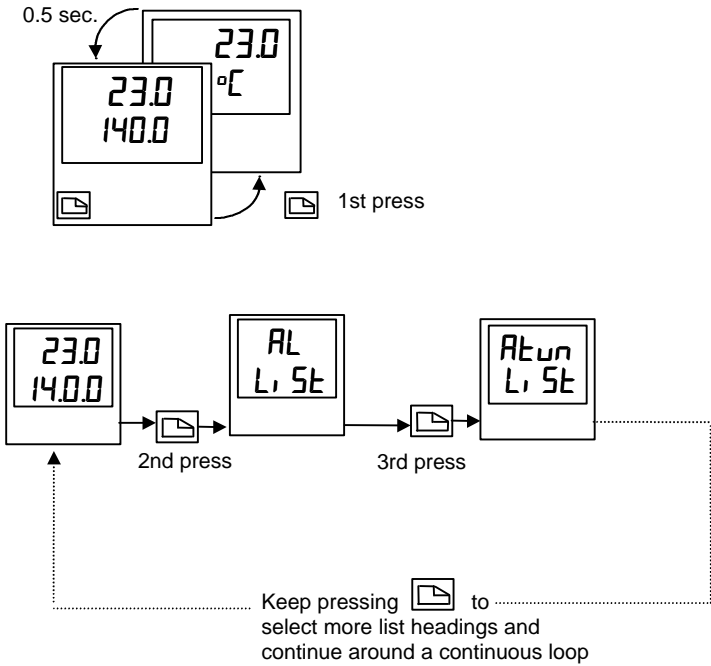



Fig. 1.7 Upper readout is parameter name. Lower is value

## USE OF THE PAGE BUTTON

The “PAGE” button  accesses parameter **LISTS**

Parameters are settings in the instrument which, generally, can be changed by the user to suit the process. Examples are: Alarms, Self-Tune, etc. They are found under headings called **LISTS** and a full set is given later in this chapter.



**Fig 1.8 Press  to choose a parameter list**

**NOTE**



The actual list headings may be longer or shorter than indicated above and you can customize this for the operator’s convenience in EDIT level, Chapter 3.



### PARAMETER LISTS

Press  to choose a LIST - "ALARMS" is a good one. This list allows you to set the alarm trip levels. The parameters, which appear in the list, will vary according to the configuration of your controller.

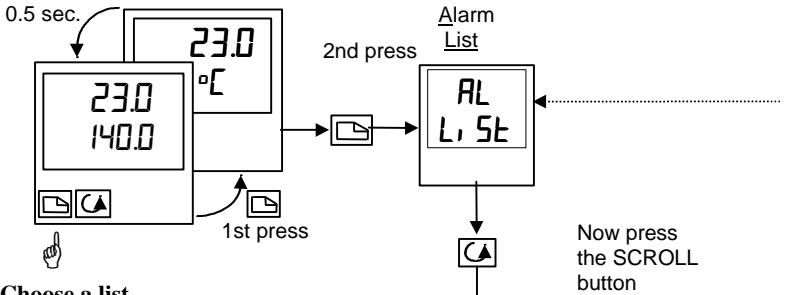

Fig. 1.9a Choose a list

There are 4 alarms in the controller. The first character is the alarm number. The following three letters indicate the alarm type as follows:

- FSL Full Scale Low
- FSH Full Scale High
- dH Deviation High
- dLo Deviation Low
- dEu Deviation Band

Disabled alarms will not be displayed. Chapter 7 gives a full description of alarms.

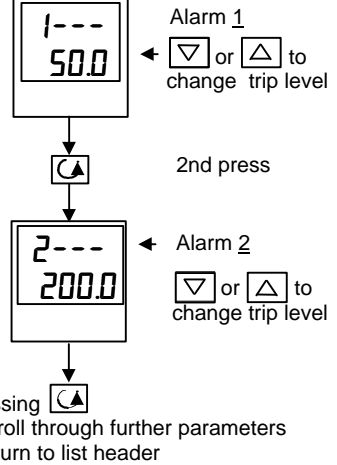

Fig. 1.9b Press  to select a parameter

**NOTE** If, at any time, no key is pressed within 45 seconds, the display will always return to the "HOME" display.



### OPERATING MODES

The controller can be used in two modes:

**Automatic mode** - in which the output power is automatically adjusted to hold the temperature at the required value. The controller normally operates in this mode.

**Manual mode** - in which the output is manually adjusted by the Operator. In this mode the 'MAN' light will be on.

One other mode is available:

**Remote setpoint** - The setpoint is generated as an input signal from a master 2000 series controller. In this mode the REM light is on.

### AUTO or MANUAL SELECT

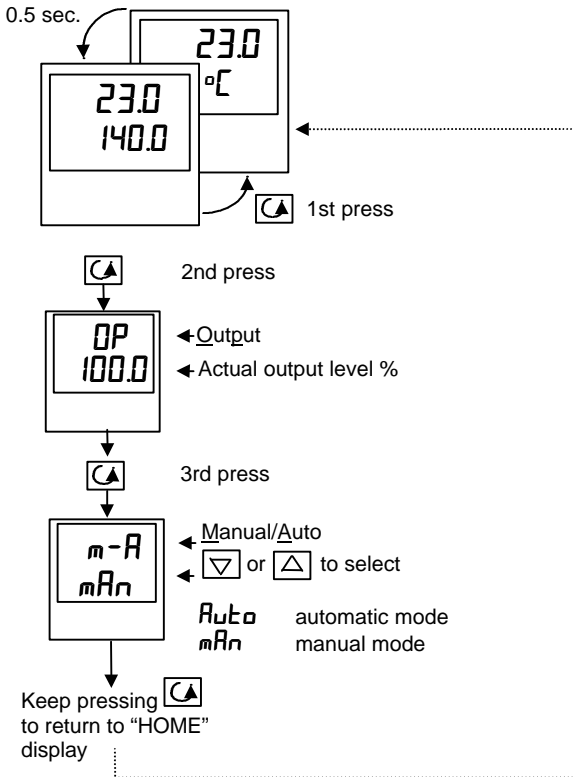
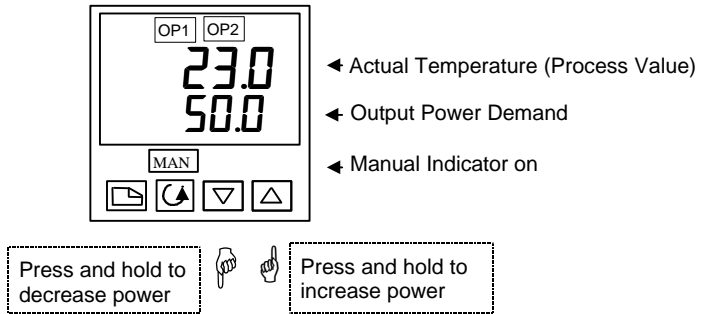

Fig. 1.10 Auto/manual select

## MANUAL ADJUSTMENT OF OUTPUT POWER



**Fig. 1.11 The “Home Display” in manual mode**

### NOTE



Manual mode is generally used for test and commissioning purposes, take care not to leave the controller in this mode since damage or personal injury could occur.

## SUMMARY

To step through list headers, press the Page button  until the required header is obtained

To step through parameters within a particular list, press the Scroll button  until the required parameter is obtained

To **change the value (or state)** of a parameter, press the Raise button  or the Lower button

**The remainder of this chapter** provides a complete list of all parameters available.

**NAVIGATION DIAGRAM (Part A)**

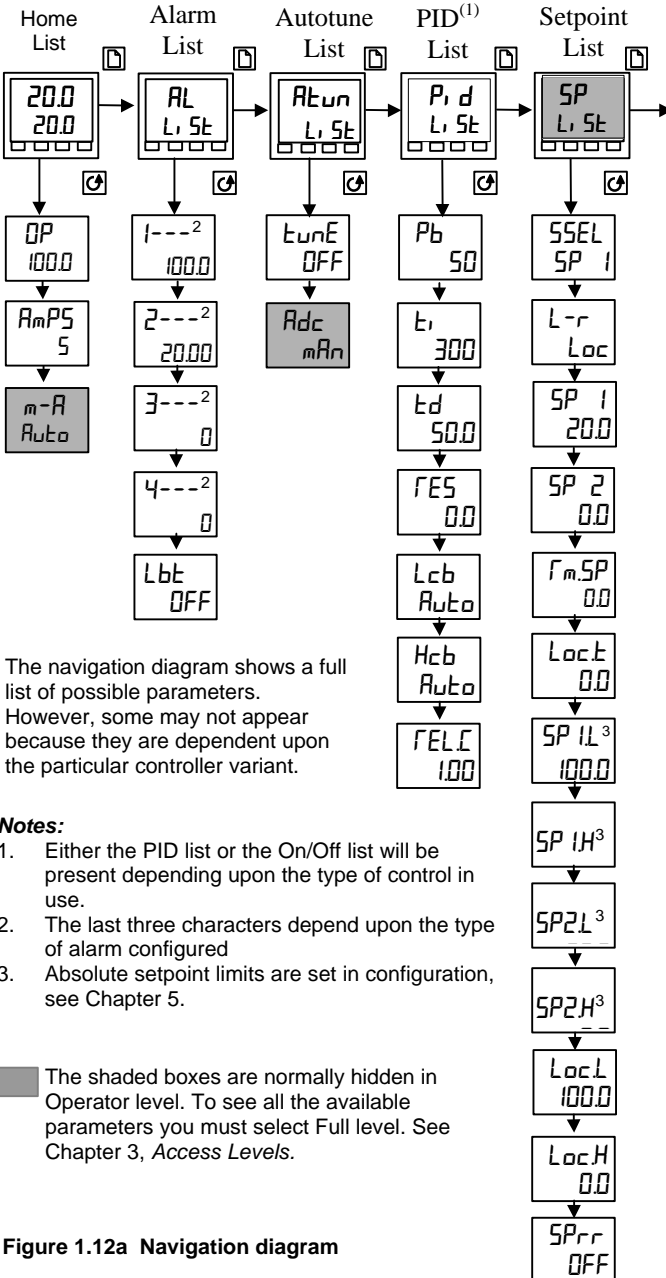

The navigation diagram shows a full list of possible parameters. However, some may not appear because they are dependent upon the particular controller variant.

**Notes:**

1. Either the PID list or the On/Off list will be present depending upon the type of control in use.
2. The last three characters depend upon the type of alarm configured
3. Absolute setpoint limits are set in configuration, see Chapter 5.

**■** The shaded boxes are normally hidden in Operator level. To see all the available parameters you must select Full level. See Chapter 3, Access Levels.

**Figure 1.12a Navigation diagram**

**NAVIGATION DIAGRAM (PART B)**

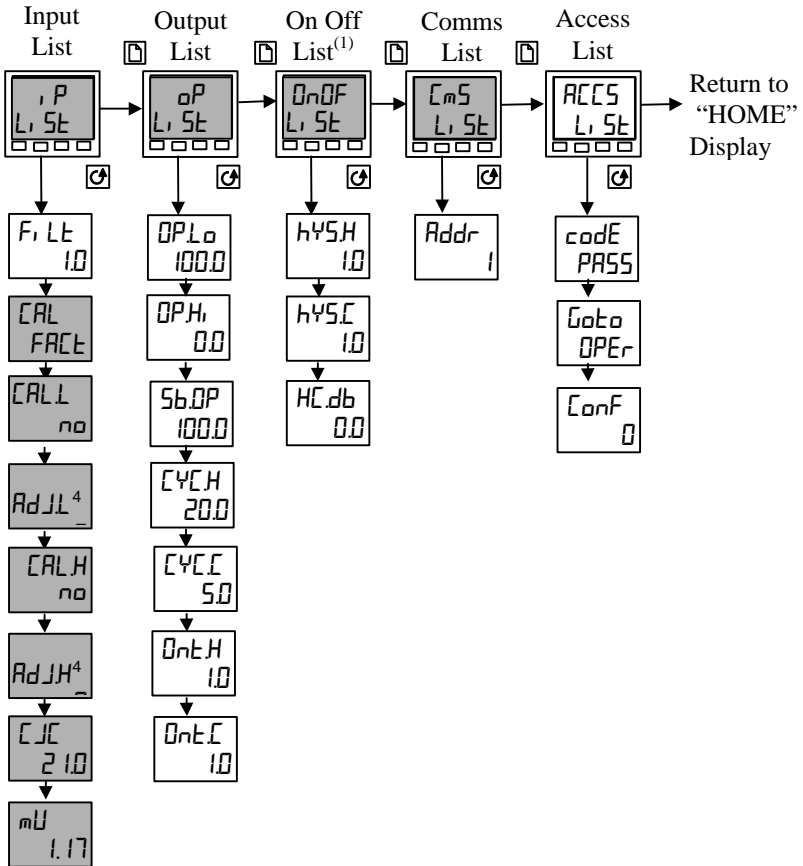

**Note:**  
 4. **Beware!** Used for calibration. See Chapter 6.

■ The shaded boxes are normally hidden in Operator level. To see all the available parameters you must select Full level. See Chapter 3, *Access Levels*.

**Figure 1.12b Navigation diagram**

## PARAMETER TABLES

Name	Parameter Description	Default Value		Minimum Value	Maximum Value	Units	Customer Setting
		UK	USA				

Home List							
Home	Measured Value and Setpoint (SP)	SP=25	SP=78			as display	
OP	% Output Level			0.00	100.00	%	
AmPS	Heater current (PDLINK mode 2)					Amps	
m-A	Auto/manual select	Auto	Auto				

Additional parameters may appear in the Home display if the 'promote' feature has been used (see *Edit Level*, Chapter 3).

AL Alarm List							
1---	Alarm 1 setpoint value	0	PER Alarm SEE below	0	9999	as display	
2---	Alarm 2 setpoint value	0	PER Alarm SEE below	0	9999	as display	
3---	Alarm 3 setpoint value	0	PER Alarm SEE below	0	9999	as display	
4---	Alarm 4 setpoint value	0	PER Alarm SEE below	0	9999	as display	

In place of dashes, the last three characters indicate the alarm type, as follows:

-FSH	Full Scale High alarm		800				
-FSL	Full Scale Low alarm		32				
-dEw	Deviation band alarm		31				
-dH	Deviation High alarm		31				
-dLo	Deviation Low alarm		31				
Lbt	Loop break time	OFF	OFF	0	9999	secs	

Name	Parameter Description	Default Value		Minimum	Maximum	Units	Customer Setting
		UK	USA	Value	Value		

<i>Autun</i>	<b>Autotune List</b>						
<i>tunE</i>	Self <u>tune</u> enable	OFF	OFF	OFF	ON		
<i>Rdc</i>	<u>A</u> utomatic <u>d</u> roop <u>c</u> ompensation (Manual Reset) enable (only present if ti set to OFF)	mAN	mAN	mAN	CRLC		

<i>P, d</i>	<b>PID List</b>						
<i>Pb</i>	Proportional <u>b</u> and	20.0	46	0.0	9999	as display	
<i>ti</i>	Integral <u>t</u> ime	360	360	OFF	9999	seconds	
<i>td</i>	Derivative <u>t</u> ime	60	60	OFF	9999	seconds	
<i>rES</i>	Manual <u>r</u> eset (appears when ti set to OFF)	0.0	0.0	0.00	100.0	%	
<i>Lcb</i>	<u>C</u> utback <u>l</u> ow	Auto	Auto	0	9999	as display	
<i>Hcb</i>	<u>C</u> utback <u>h</u> igh	Auto	Auto	0	9999	as display	
<i>rELC</i>	<u>R</u> elative <u>c</u> ool gain (set 1)	1.00	1.00	0.01	9.99		

Name	Parameter Description	Default Value		Minimum	Maximum	Units	Customer Setting
		UK	USA	Value	Value		

SP	Set Point List						
<i>SEEL</i>	Select SP1 or SP2	<i>SP 1</i>	<i>SP 1</i>	<i>SP 1</i>	<i>SP 2</i>		
<i>L-r</i>	Local or remote setpoint select *	<i>Loc</i>	<i>Loc</i>	<i>Loc</i>	<i>rmE</i>		
<i>SP 1</i>	Setpoint 1 value	25	78	As display range			
<i>SP 2</i>	Setpoint 2 value	25	78	As display range			
<i>rm.SP</i>	Remote setpoint	0	32	As display range			
<i>Loc.t</i>	Local trim	0	0	As display range			
<i>SP 1L</i>	Setpoint 1 low limit	0	32	As display range			
<i>SP 1H</i>	Setpoint 1 high limit	1000	800	As display range			
<i>SP 2L</i>	Setpoint 2 low limit	0	32	As display range			
<i>SP 2H</i>	Setpoint 2 high limit	1000	800	As display range			
<i>Loc.L</i>	Local setpoint trim low limit	-2 10	-340	As display range			
<i>Loc.H</i>	Local setpoint trim high limit	1200	2192	As display range			
<i>SPrr</i>	Setpoint rate limit	OFF	OFF	As display range			

\* Only appears if PDLINK fitted and configured in the *HA* comms slot.



Name	Parameter Description	Default Value		Minimum	Maximum	Units	Customer Settings
		UK	USA	Value	Value		

$i, P$	Input list						
$F, L, T$	Input filter time constant	16	16	1.0	999.9	secs	
The next 5 parameters will appear if User calibration has been enabled in configuration level. To perform a user calibration, refer to Ch 6.							
$CAL$	$FALSE$ will re-instate factory settings and disable User Calibration. Default setting $FALSE$ $USER$ will re-instate any previously set User Calibration offsets and make available User Calibration parameters as follows:						
$CALL$	User low point calibration	if $YES$ allows access to next parameter.		if $no$ the next parameter is hidden			
$Adj.L^{\circ}$	Adjust low point to calibrated ref. source						
$CAL.H$	User high point calibration	if $YES$ allows access to the next parameter		if $no$ the next parameter is hidden			
$Adj.H^{\circ}$	Adjust high point to calibrated ref. source						
The following two parameters are always present in Full Access level but not in Operator level							
$CJC^{\circ}$	Cold Junction compensation temperature						
$mV$	Millivolt input						
* Do not make adjustments to the Adj.L or Adj.H parameters unless you wish to offset the controller calibration							

$oP$	Output list	Note: If On/Off control is configured only $Sb.OP$ , $onT.H$ and $onT.C$ will appear in the following list					
$OP.Lo$	Low (power) output limit	0.0 or -100.0 (cool)	-100.0	100.0	%		
$OP.Hi$	High (power) output limit	100.0	100.0	-100.0	100.0	%	
$Sb.OP$	Output setting when in sensor break	0.0 or -100.0 (cool)	-100.0	100.0	%		
$CYC.H$	Heat cycle time	1.0 (dc pulse) 2.0 (relay)	0.2	999.9	secs		
$CYC.C$	Cool cycle time	1.0 (dc pulse) 2.0 (relay)	0.2	999.9	secs		
$onT.H$	Heat output min. on time	0.1	0.1	$R_{ute}$ (50mS)	1.0	mins	
$onT.C$	Cool output min. on time	0.1	0.5	$R_{ute}$ (50mS)	1.0	mins	

Name	Parameter Description	Default Value		Minimum	Maximum	Units	Customer Settings
		UK	USA	Value	Value		

<b>OnOff</b>	<b>On/off list</b>						
This set of parameters only appear if On/Off control has been configured							
<i>hYSH</i>	Heat hysteresis	0	0	0	9999	as display	
<i>hYSc</i>	Cool hysteresis	0	0	0	9999	as display	
<i>HEdb</i>	Heat/Cool dead band	1	1	0	9999	as display	

<b>cmS</b>	<b>Comms list</b>						
<i>Addr</i>	Communications address	1	1	1	254		

<b>ACCESS</b>	<b>Access list</b>						
<i>codE</i>	Full and Edit level password	1	1	0	9999		
<i>Goto</i>	Goto level -OPER, FULL, Edit or CONF	OPER	OPER	OPER	CONF		
<i>CONF</i>	Configuration level password	2	2	0	9999		

## SETTING ALARM LEVELS

Up to 4 Alarms may be configured. Each alarm is given a name to describe its function - see table below. If an alarm is not used it does not appear in the list below.

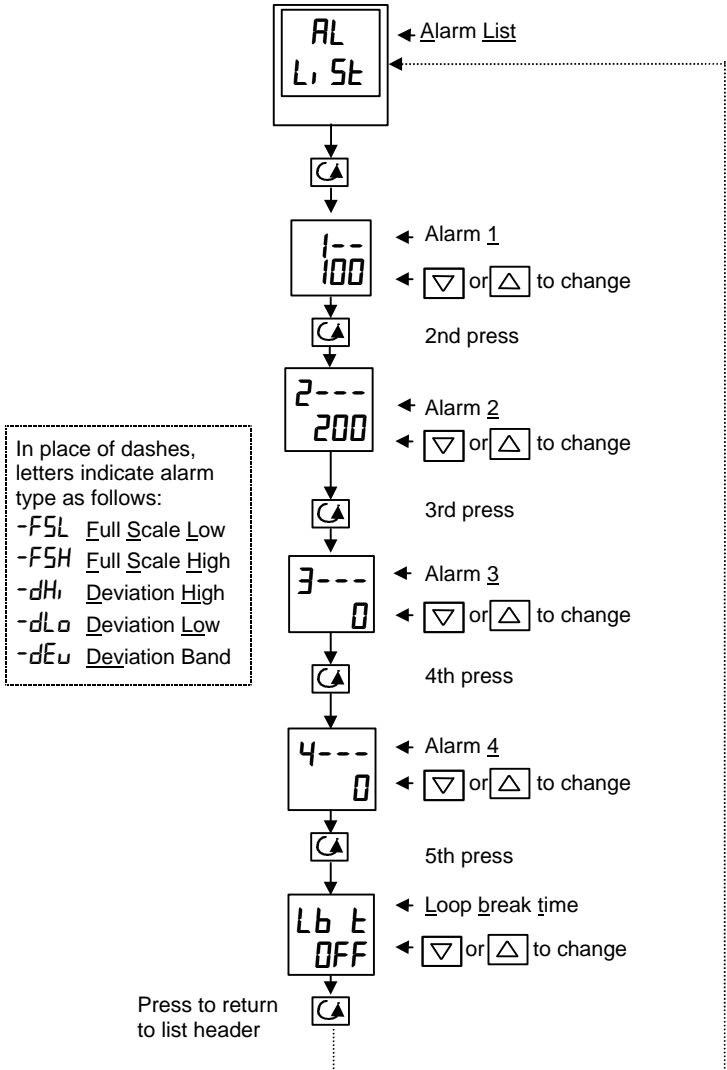

## Diagnostic alarms

These indicate that a fault exists in either the controller or the connected devices.

**Table 1.1a Diagnostic alarms**

Display shows	What it means	What to do about it
<i>EEEr</i>	<i>Electrically Erasable Memory Error:</i> The value of an operator or configuration parameter has been corrupted.	This fault will automatically take you into configuration level. Check all of the configuration parameters before returning to operator level. Once in operator level, check all of the operator parameters before resuming normal operation. If the fault persists or occurs frequently, contact Omega Engineering, Inc.
<i>Sbr</i>	<i>Sensor Break:</i> Input sensor is unreliable or the input signal is out of range.	Check that the sensor is correctly connected.
<i>Lbr</i>	<i>Loop Break:</i> The feedback loop is open circuit.	Check that the heating and cooling circuits are working properly.
<i>LdF</i>	<i>Load failure</i> Indication that there is a fault in the heating circuit or the solid state relay.	This is an alarm generated by feedback from a Omega SSC-TE10S solid state relay (SSR) operating in PDLINK mode 1-see <i>Electrical installation</i> Chapter 2. It indicates either an open or short circuit SSR, blown fuse, missing supply or open circuit heater.
<i>SSrF</i>	<i>Solid state relay failure</i> Indication that there is a fault in the solid state relay	This is an alarm generated by feedback from a Omega SSC-TE10S solid state relay (SSR) operating in PDLINK mode 2 -see <i>Electrical installation</i> Chapter 2. It indicates either an open or short circuit condition in the SSR.
<i>HTrF</i>	<i>Heater failure</i> Indication that there is a fault in heating circuit	This is an alarm generated by feedback from a Omega SSC-TE10S solid state relay (SSR) operating in PDLINK mode 2 -see <i>Electrical installation</i> Chapter 2. It indicates either a blown fuse, missing supply or open circuit heater.
<i>HwEr</i>	<i>Hardware error</i> Indication that a module is of the wrong type, missing or faulty	Check that the correct modules are fitted.

## Diagnostic alarms continued

These indicate that a fault exists in either the controller or the connected devices.

**Table 1.1b Diagnostic alarms**

Display shows	What it means	What to do about it
<i>rmlF</i>	<i>Remote input failure.</i> The PDLINK input is open circuit	Check for open or short circuit wiring on the PDLINK input
<i>LLLL</i>	<i>Out of Display range, low reading</i>	Check the value of the display range
<i>HHHH</i>	<i>Out of Display range, high reading</i>	Check the value of the display range
<i>Err 1</i>	<i>Error 1: ROM self-test fail</i>	Return the controller for repair
<i>Err 2</i>	<i>Error 2: RAM self-test fail</i>	Return the controller for repair
<i>Err 3</i>	<i>Error 3: Watchdog fail</i>	Return the controller for repair
<i>Err 4</i>	<i>Error 4: Keyboard failure</i> Stuck buttons, or a button was pressed during power up.	Switch the power off and then on without touching any of the controller buttons.
<i>Err 5</i>	<i>Error 5: Input circuit failure</i>	Return the controller for repair
<i>PwrF</i>	<i>Power failure.</i> The line voltage is too low	Check that the supply to the controller is within the rated limits



## Chapter 2 INSTALLATION

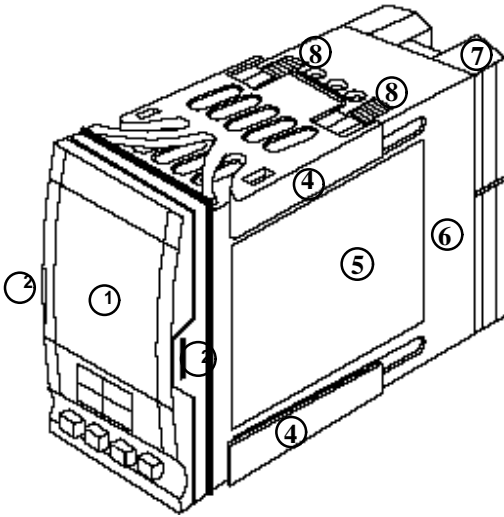

KEY

- 1. Display screen
- 2. Latching ears
- 3. Panel sealing gasket
- 4. Panel retaining clips
- 5. Label
- 6. Sleeve
- 7. Terminal covers
- 8. Ratchets

Figure 2-1 CN2208 1/8 DIN controller

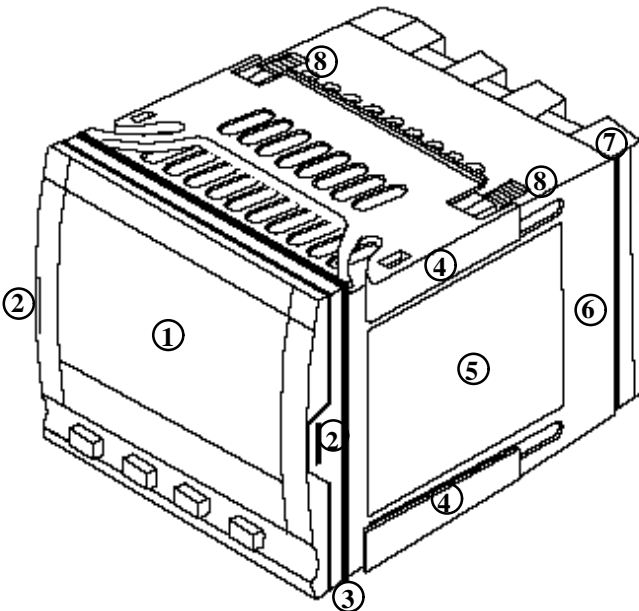
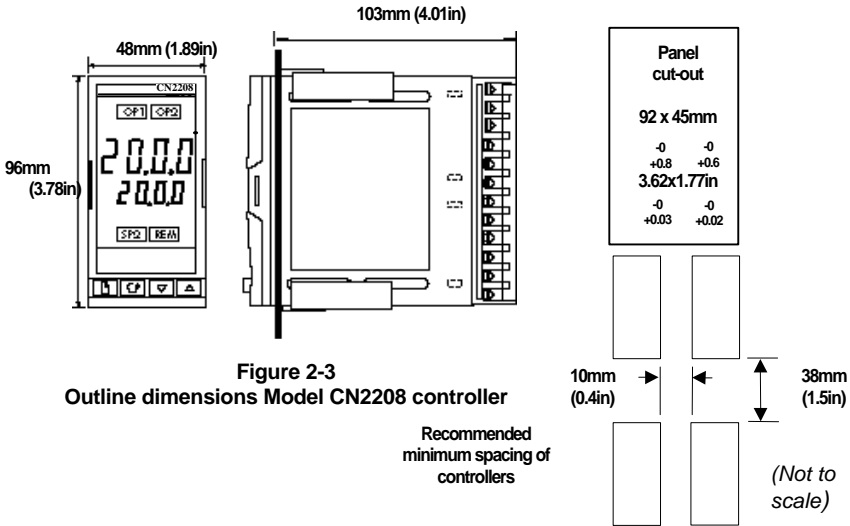
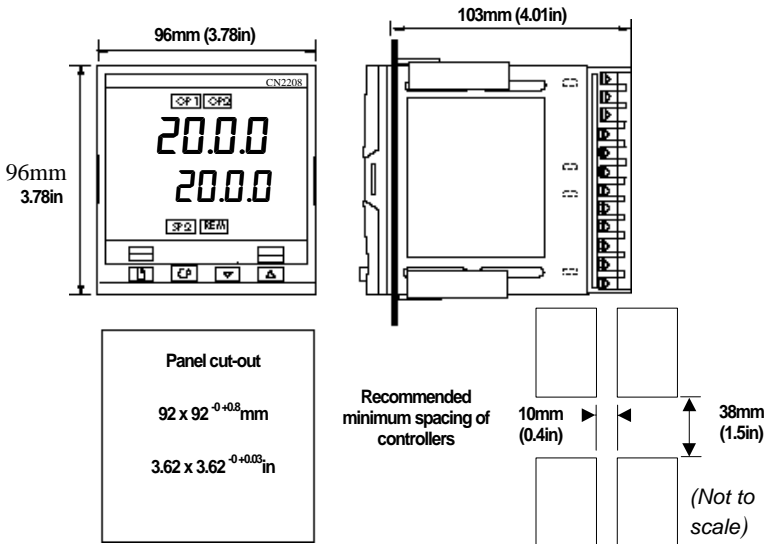

Figure 2-2 CN2404 1/4 DIN controller

**Outline dimensions Model CN2208**



**Outline dimensions Model CNCN2204**



**Figure 2-4** Outline dimensions Model CNCN2204 controller  
The controller plugs into a plastic sleeve, which in turn fits into the panel cut-out shown in Figures 2-3 and 2-4.



## INTRODUCTION

The Models CN2208 and CN2204 are precision temperature controllers with self-tuning. They have a modular hardware construction, which provides two control outputs, two alarm relays and one communications port. Two logic inputs are provided as standard. In addition the Model CN2204 has an optional plug-in 10A relay heating output.

### Controller labels

The labels on the sides of the controller identify the ordering code, the serial number, and the wiring connections.

Appendix A, *Understanding the Ordering Code* explains the hardware and software configuration of your particular controller.

## MECHANICAL INSTALLATION

### To install the controller

1. Cut the panel to the relevant hole size shown in Figure 2-3 and 2.4.
2. Insert the controller through the front of this cut-out.
3. Spring the upper and lower panel retaining clips into place. Secure the controller in position by holding it level and pushing both retaining clips forward.

Note: If the panel retaining clips subsequently need removing, they can be unhooked from the side with either your fingers or a screwdriver.

### Unplugging and plugging-in the controller

The controller can be unplugged from its sleeve by easing the latching ears outwards and pulling it forward out of the sleeve. When plugging the controller back into its sleeve, ensure that the latching ears click into place to maintain the IP65 sealing.

## WIRING

Please read Appendix B, safety and EMC information before proceeding.

### WARNING

Please ensure that the controller is correctly configured for your application. Incorrect configuration could result in damage to the process being controlled, and/or personal injury. The controller may either have been configured when ordered, or may need configuring now. See Chapter 5, *Configuration*.

### Model CN2208 connections

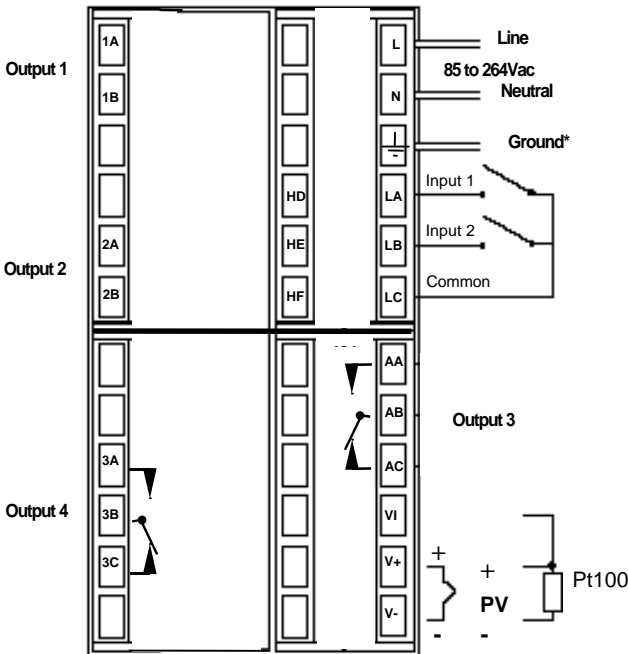

Figure 2-5 Model CN2208 wiring connections

\* The ground connection is not required for electrical safety but must be connected to satisfy EMC requirements.

**Wire Sizes**

All electrical connections are made to the screw terminals at the rear of the controller. These accept wire sizes from 0.5 to 1.5 mm<sup>2</sup> (16 to 22 AWG), and are protected by a hinged cover to prevent hands or metal making accidental contact with live wires. Rear terminal screws should be tightened to a torque of 0.4 Nm (3.5 lb. in).

**Wiring connections**

The wiring connections are shown in figures 2-5 and 2-6.

Outputs 1 and 2 are factory fitted modules which can be any one of the types shown in figure 2-8. Check the ordering code on the controller side label to determine which have been fitted.

**Model CN2204 connections**

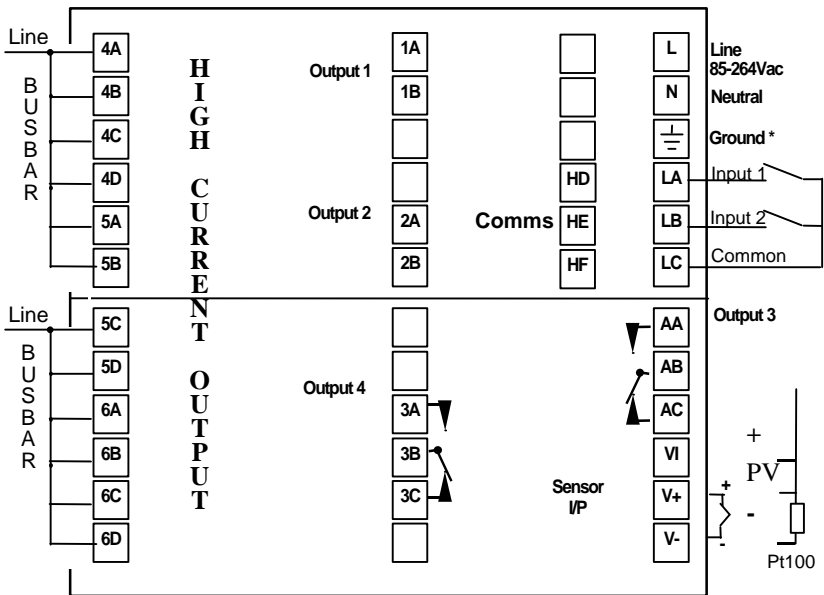

**Figure 2-6 Model CN2204 Wiring connections**

\* The ground connection is not required for safety purposes but must be connected to satisfy EMC requirements.

### Sensor input connections

The connections for the various types of input are as follows:

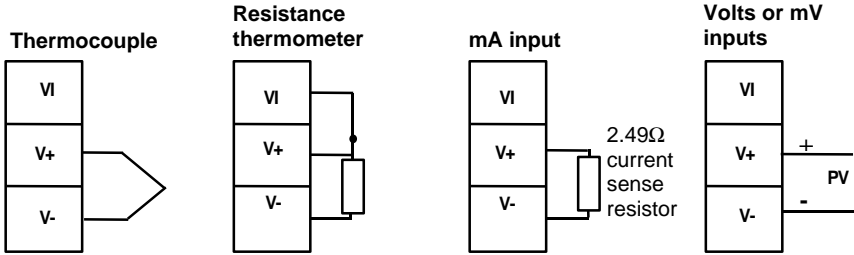

Fig 2-7 Sensor input connections

### OUTPUTS 1 AND 2 CONNECTIONS

Outputs 1 and 2 can be any one of the types shown in the table below. Configured to perform any one of the functions shown.

To check which outputs are installed, and their configuration, refer to the ordering code and the wiring information on the controller side labels.

Module type	Connections				Possible functions
	Output 1		Output 2		
	1A	1B	2A	2B	
Relay: 2-pin (2A, 264 Vac max.)					Heating Cooling Alarms
dc pulse: non-isolated (18Vdc at 24mA)					PDLINK modes 1 or 2 Heating Cooling Alarms
AC SSR (1A, 30 to 264Vac)					Heating or cooling
DC control: isolated (18Vdc, 20mA max)			DC not available in output 2		PID Heating or cooling

Figure 2-8 Outputs 1 and 2 connections

## PDLINK modes

**PDLINK** is a technique for bi-directional communications over a single pair of wires. There are two operating modes.

In **mode 1** a dc pulse output delivers a power demand signal to a SSC-TE10 solid state relay (SSR) and the SSR responds with a single load circuit failure message.

In **mode 2** a dc pulse output delivers a power demand signal to an SSR and the SSR responds with the ON state rms load current, and two fault messages - SSR failure or heater circuit failure.

## Snubbers

The controller is supplied with ‘snubbers’ (15nF +100Ω) which should be wired across the relay or AC SSR outputs when switching inductive loads such as mechanical contactors and solenoid valves. The snubbers are used to prolong contact life and to suppress interference when switching such loads.

Snubbers pass 0.6mA at 110Vac and 1.2mA at 240Vac, which may be sufficient to hold in high impedance relay coils. They should not, therefore, be used in such installations.

## WARNING

When a relay contact is used in an alarm circuit, ensure that the current passing through the snubber when the relay contact is open does not hold in low power electrical loads and thereby interfere with the failsafe operation of the alarm circuit.

## COMMUNICATIONS CONNECTIONS

The communications option can be either of the two types shown in the table below:

Communications type	Connection		
	HD	HE	HF
2 wire RS-485 (EIA- 485) serial communications	Common	A	B
PDLINK Setpoint input	Not used	Signal	Common

**Figure 2-9 Communication connections**

The RS-485 (EIA- 485) module can be configured for Modbus® protocol.

### Wiring of RS-485 (EIA 485) serial communication links

2-wire RS-485 (EIA-485) is a connection, which allows up to 32 controllers to be multi-dropped from a single communications link over a distance of up to 1.2Km. To ensure reliable operation of the communications link, (without data corruption due to noise or line reflections) the connections between the controller should be made using a twisted pair of wires inside a screened cable with the connections terminated with resistors in the manner shown in this diagram. This diagram also shows the use of a communications isolator/convertor to connect the RS-485 (EIA-485) link into a standard RS-232 (EIA-232) computer port.

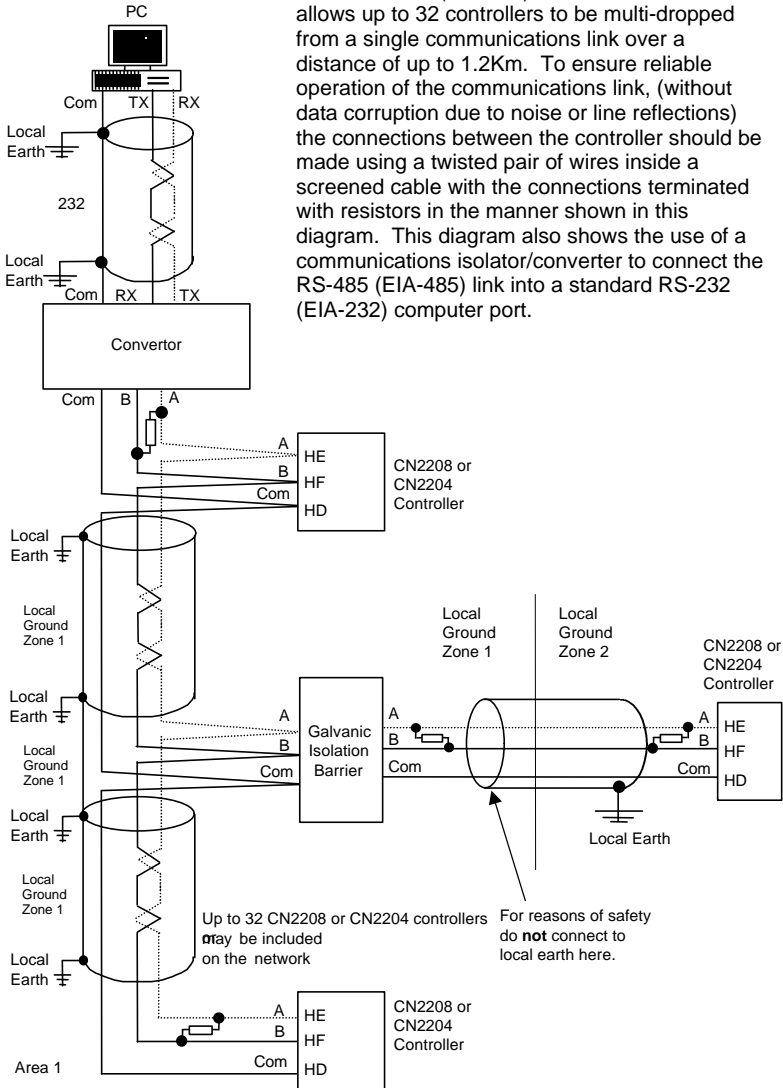

**Note:**  
 All resistors are 220 ohm 1/4W carbon composition.  
 Local grounds are at equipotential. Where equipotential is not available wire into separate zones using a galvanic isolator.  
 Use a repeater for more than 32 units.

Figure 2-10 RS-485 (EIA 485) wiring

### TYPICAL WIRING DIAGRAM

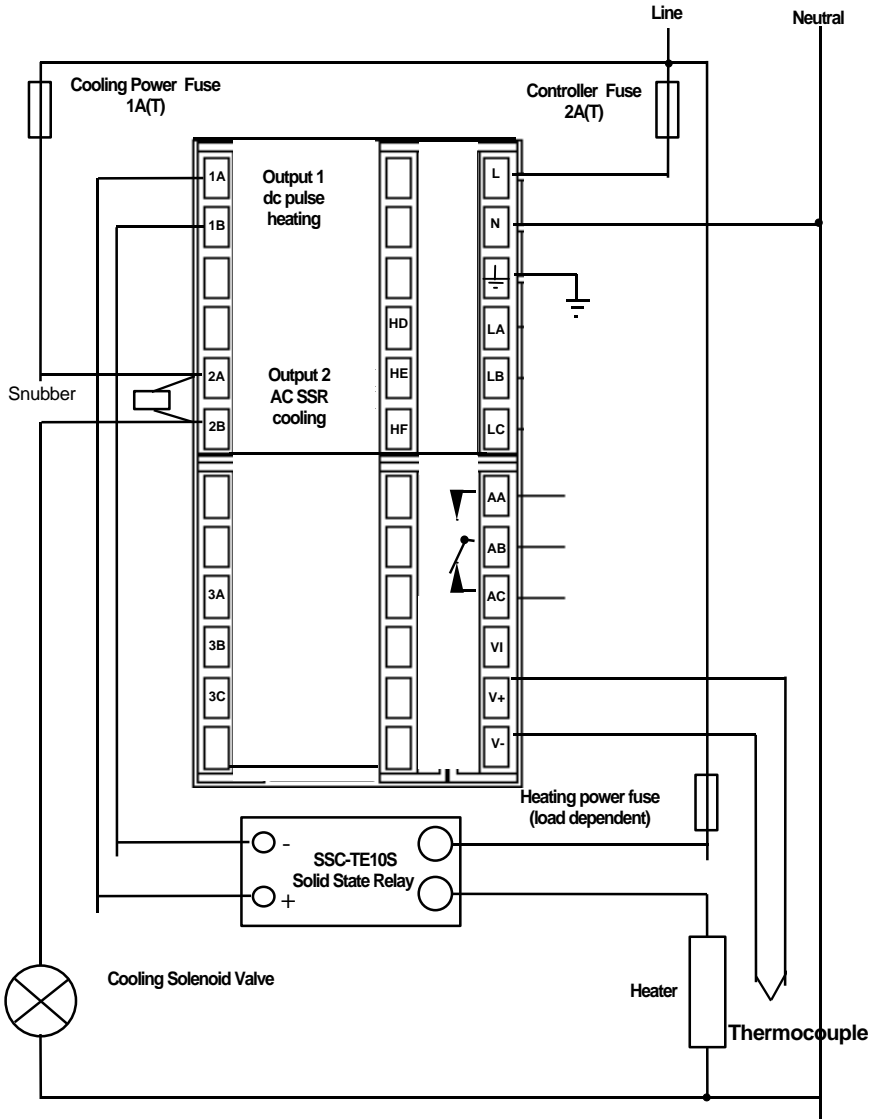

Fig 2-11 Typical wiring diagram, Model CN2208 Controller





## Chapter 3 ACCESS LEVELS

This chapter describes the different levels of access to the operating parameters within the controller.

There are three topics:

- THE DIFFERENT ACCESS LEVELS
- SELECTING AN ACCESS LEVEL
- EDIT LEVEL

### THE DIFFERENT ACCESS LEVELS

There are four access levels:

- **Operator level**, which you will normally use to operate the controller
- **Configuration level**, which is used to set up the fundamental characteristics of the controller
- **Full level**, which is used to commission the controller and the process being controlled
- **Edit level**, which is used to set up the parameters that you want an operator to be able to see and adjust when in Operator level.

Access level	Display shows	What you can do	Password Protection
Operator	<i>OPER</i>	In this level operators can view and adjust the value of parameters defined in Edit level (see below).	No
Full	<i>FULL</i>	In this level all the parameters relevant to a particular configuration are visible. All alterable parameters may be adjusted.	Yes
Edit	<i>EDIT</i>	In this level you can set which parameters an operator in Operator level is able to view and adjust. You can hide or reveal complete lists and individual parameters within each list, and you can make parameters read-only or alterable. (See <i>Edit level</i> at the end of the chapter).	Yes
Configuration	<i>CONF</i>	This special level allows access to set up the fundamental characteristics of the controller.	Yes

**Figure 3-1 Access levels**

## SELECTING AN ACCESS LEVEL

Access to Full, Edit or Configuration levels is protected by a password to prevent unauthorized access. If you need to change the password, see Chapter 5, *Configuration*.

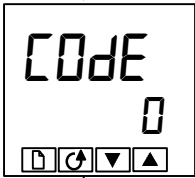



### Access list header

Press  until you reach the access list header 'ACC<sup>S</sup>'.

*Press the Scroll button*

### Password entry

The password is entered from the 'Code' display.



Enter the password using the  or  buttons. Once the correct password has been entered, there is a two second delay after which the lower readout will change to show 'PASS' indicating that access is now unlocked.



The pass number is set to '1' when the controller is shipped from the factory.

*Note:* A special case exists if the password has been set to '0'. In this case access will be permanently unlocked and the lower readout will always show 'PASS'.

*Press the Scroll button to proceed to the 'GOTO' display.*

(If an *incorrect* password has been entered and the controller is still 'locked' then pressing *Scroll* at this point will simply return you to the *ACC<sup>S</sup>* list header.)

*Note:* From this 'CODE' display you can access 'read only' configuration level by pressing  and  together.

To escape read only configuration press  and  together.



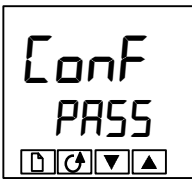

Alternative path if 'conf' selected



**Level selection**

The 'Goto' display allows you to select the required access level.

Use  and  to select from the following display codes: **OPER**:

- Operator level
- FULL**: Full level
- Edit**: Edit level
- CONF**: Configuration level

Press the Scroll button

If you selected either 'OPER', 'FULL' or 'Edit' level you will be returned to the 'ACCESS' list header in the level that you chose. If you selected 'CONF', you will get an alternative display showing 'CONF' in the upper readout (see below).

**Configuration password**

When the 'CONF' display appears, you must enter the Configuration password in order to gain access to Configuration level. Do this by repeating the password entry procedure described in the previous section

The configuration password is set to '2' when the controller is shipped from the factory. If you need to change the configuration password, see Chapter 5, *Configuration*

Press the Scroll button

**Configuration level**

The first display of configuration is shown. See chapter 5, *Configuration* for details of the configuration parameters. For instructions on leaving configuration level see Chapter 5, *Configuration*.

**Returning to Operator Level**

To return to operator level from either 'FULL' or 'Edit' level, repeat entry of the password and select 'OPER' on the 'Goto' display.

In 'Edit' level the controller will automatically return to operator level if no button is pressed for 45 seconds.



## EDIT LEVEL

Edit level is used to set which parameters you can see and adjust in Operator level. It also gives access to the 'Promote' feature which allows you to select and add ('Promote') up to twelve parameters into the Home display list, thereby giving simple access to commonly used parameters.

### Setting operator access to a parameter

First you must select **Edi t** level, as shown on the previous page.

Once in **Edi t** level, you select a list or a parameter within a list in the same way as you would in Operator or Full level. That is to say, you move from list header to list header by pressing the Page button, and from parameter to parameter within each list using the Scroll button. **However, in Edit level what is displayed is not the value of a selected parameter but a code representing the parameter's availability in Operator level.**

When you have selected the required parameter, use the  and  buttons to set its availability in operator level.

There are four codes:

- ALtr** Makes a parameter alterable in Operator level
- Pro** Promotes a parameter into the Home display list
- FEAd** Makes a parameter or list header read-only (*it can be viewed but not altered*)
- Hi dE** Hides a parameter or list header.

For example:



The parameter selected is the set point for Alarm 2 - Full Scale Low

### Hiding or revealing a complete list

To hide a complete list of parameters, all you have to do is hide the list header. If a list header is selected only two selections are available: **FEAd** and **Hi dE**.

(It is not possible to hide the 'ACCs' list, which will always display the code: 'L, St'.)

### Promoting a parameter

Scroll through the lists to the required parameter and choose the '**Pro**' code. The parameter is then automatically added (promoted) into the Home display list (the parameter will also be accessible as normal from the standard lists. a maximum of twelve parameters can be promoted. Promoted parameters are automatically 'alterable'.

## Chapter 4 TUNING

Before tuning please read Chapter 1, *Operation*, to learn how to select and change a parameter.

This chapter has three main topics:

- WHAT IS TUNING?
- AUTOMATIC TUNING
- MANUAL TUNING

### WHAT IS TUNING?

In tuning you match the characteristics of the controller to that of the process being controlled in order to obtain good control. Good control means:

- Stable ‘straight-line’ control of the temperature at setpoint without fluctuation
- Acceptable overshoot or undershoot of the temperature setpoint
- Quick response to deviations from the setpoint caused by external disturbances, thereby restoring the temperature rapidly to the setpoint value.

Tuning involves calculating and setting the value of the parameters listed in Table 4-1. These parameters appear in the  $P, I, D$  list.

**Table 4-1 Tuning parameter**

Parameter	Code	Meaning or Function
Proportional band	$Pb$	The bandwidth in display units over which the output power is proportioned between minimum and maximum.
Integral time	$t_i$	Determines the time taken by the controller to remove steady-state error signals.
Derivative time	$t_d$	Determines how strongly the controller will react to the rate-of-change of the measured value.
Low cutback	$Lcb$	The number of display units below setpoint at which the controller will cutback the output power in order to prevent overshoot on heat up.
High Cutback	$Hcb$	The number of display units above setpoint at which the controller will increase the output power in order to prevent undershoot on cool down.
Relative cool gain	$rELC$	Only present if cooling has been configured. Sets the cooling proportional band by dividing the $Pb$ value by the $rEL$ value.

## AUTOMATIC TUNING

This method automatically determines the value of the parameters listed in table 4-1 on the previous page.

The CN2208 and CN2204 use a 'one-shot' tuner which works by switching the output on and off to induce an oscillation in the measured value. From the amplitude and period of the oscillation, it calculates the tuning parameter values.

If the process cannot tolerate full heating or cooling being applied during tuning, then the level of heating or cooling can be restricted by setting the heating and cooling power limits in the Output list. However, the measured value *must* oscillate to some degree for the tuner to be able to calculate values

A One-shot Tune can be performed at any time but normally it is performed only once during the initial commissioning of the process. However, if the process under control subsequently becomes unstable (because its characteristics have changed), you can re-tune again for the new conditions.

It is best to start tuning with the process at ambient temperature. This allows the tuner to calculate more accurately the low cutback and high cutback values that restrict the amount of overshoot or undershoot.

### Heating and Cooling Output Cycle Times

Before commencing a tuning cycle, set the values of  $[YCH]$  (heat cycle time) and  $[YCL]$  (cool cycle time) in the  $OP$  (output list). These values apply if you are using a dc pulse, relay or AC SSR output. They have no effect on a DC output.

A dc pulse output switching a solid state relay should be set to 1 sec.

A relay or AC SSR output should be set to 20 sec.

## How to tune

1. Set the setpoint to the value at which you will normally operate the process.
2. In the 'Auto' list, select 'TUNE' and set it to 'on'
3. Press the Page and Scroll buttons together to return to the Home display. The display will flash 'TUNE' to indicate that tuning is in progress.
4. The controller will induce an oscillation in the temperature by turning the heating on and then off. The first cycle will not complete until the measured value has reached the required setpoint.
5. After two cycles of oscillation the tuning will be completed and the tuner will switch itself off.
6. The controller will then calculate the tuning parameters listed in Table 4-1 and will resume normal control action.

If you want 'Proportional only' or 'PD' or 'PI' control, you should set the 'P', 'I' or 'D' parameters to OFF before commencing the tuning cycle. The tuner will leave them off and will not calculate a value for them.

## Typical automatic tuning cycle

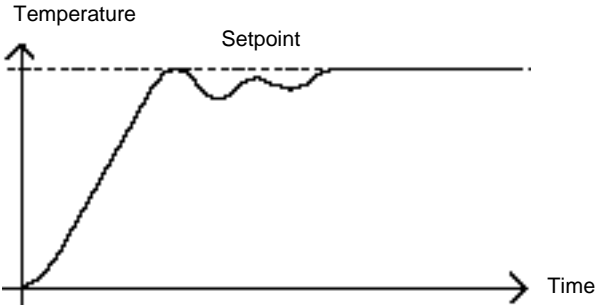

## Calculation of the cutback values

*Low cutback* and *High cutback* are values that restrict the amount of overshoot or undershoot that occurs during large step changes in temperature (for example, under start-up conditions).

If either low cutback or high cutback is set to 'Auto' the values will be fixed at three times the proportional band, and will not be changed during automatic tuning.

## MANUAL TUNING

If for any reason automatic tuning gives unsatisfactory results, you can tune the controller manually. There are a number of standard methods for manual tuning. The one described here is the Ziegler-Nichols method.

With the process at its normal running temperature:

1. Set the Integral Time ' $t_i$ ' and the Derivative Time ' $t_d$ ' to *OFF*.
2. Set High Cutback and Low Cutback, ' $Hcb$ ' and ' $Lcb$ ', to *Auto*
3. Ignore the fact that the temperature may not settle precisely at the setpoint
4. If the temperature is stable, reduce the proportional band ' $Pb$ ' so that the temperature just starts to oscillate. If the temperature is already oscillating, increase the proportional band until it just stops oscillating. Allow enough time between each adjustment for the loop to stabilize. Make a note of the proportional band value ' $B$ ' (engineering units) and the period of oscillation ' $T$ ' (seconds or minutes)
5. Set the  $Pb$ ,  $t_i$ ,  $t_d$  parameter values according to the calculations given in Table 4-2.

**Table 4-2 Tuning values**

Type of control	Proportional band ' $Pb$ '	Integral time ' $t_i$ '	Derivative time ' $t_d$ '
Proportional only	2xB	OFF	OFF
P + I control	2.2xB	0.8xT	OFF
P + I + D control	1.7xB	0.5xT	0.12xT



### Setting the cutback values

The above procedure sets up the parameters for optimum steady state control. If unacceptable levels of overshoot or undershoot occur during start-up or for large step changes in temperature, then manually set the cutback parameters  $L_{cb}$  and  $H_{cb}$ .

#### Proceed as follows:

1. Set the low and high cutback values to three proportional bandwidths (that is to say,  $L_{cb} = H_{cb} = 3 \times P_b$ ).
2. Note the level of overshoot or undershoot that occurs for large temperature changes (see the diagrams below).

In example (a) increase  $L_{cb}$  by the overshoot value. In example (b) reduce  $L_{cb}$  by the undershoot value.

#### Example (a)

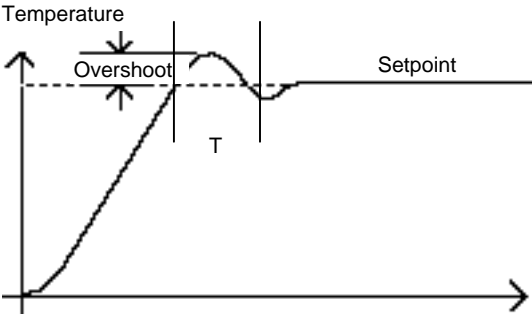

#### Example (b)

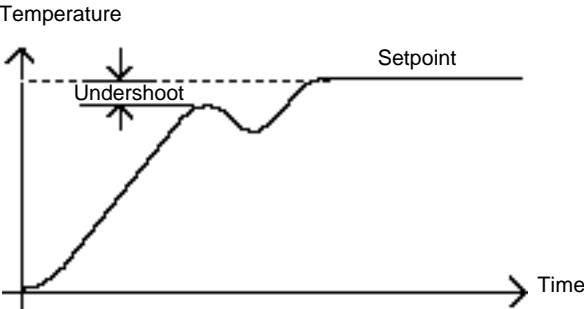

Where the temperature approaches setpoint from above, you can set  $H_{cb}$  in a similar manner.

### Integrating action and manual reset

In a full three-term controller (that is, a PID controller), the integral term '*I*' automatically removes steady state errors from the setpoint. If the controller is set up to work in two-term mode (that is, PD mode), the integral term will be set to '*OFF*'. Under these conditions the measured value may not settle precisely at setpoint. When the integral term is set to '*OFF*' the parameter *manual reset* (code *rES*) appears in the *P, d L, SE* in '*FULL*' Access level. This parameter represents the value of the power output that will be delivered when the error is zero. You must set this value manually in order to remove the steady state error.

### Automatic droop compensation (Adc)

The steady state error from the setpoint, which occurs when the integral term is set to '*OFF*', is sometimes referred to as '*droop*'. *Adc* automatically calculates the manual reset value in order to remove this droop. To use this facility, you must first allow the temperature to stabilize. Then, in the autotune parameter list, you must set *Adc* to '*CALC*'. The controller will then calculate a new value for manual reset, and switch *Adc* to '*MAN*'.

*Adc* can be repeated as often as you require, but between each adjustment you must allow time for the temperature to stabilize.

# Chapter 5 CONFIGURATION

	PAGE
Selecting Configuration Level	5-2
Selecting a Configuration Parameter .....	5-3
Leaving Configuration .....	5-3
Navigation Diagram.....	5-4
Parameter Tables.....	5-6

---

## **WARNING**

**Configuration is protected by a password and should be carried out by an authorized person. Incorrect configuration could result in damage to the process being controlled and/or personal injury. It is the responsibility of the person commissioning the process to ensure that the configuration is correct.**

---

### SELECTING CONFIGURATION LEVEL

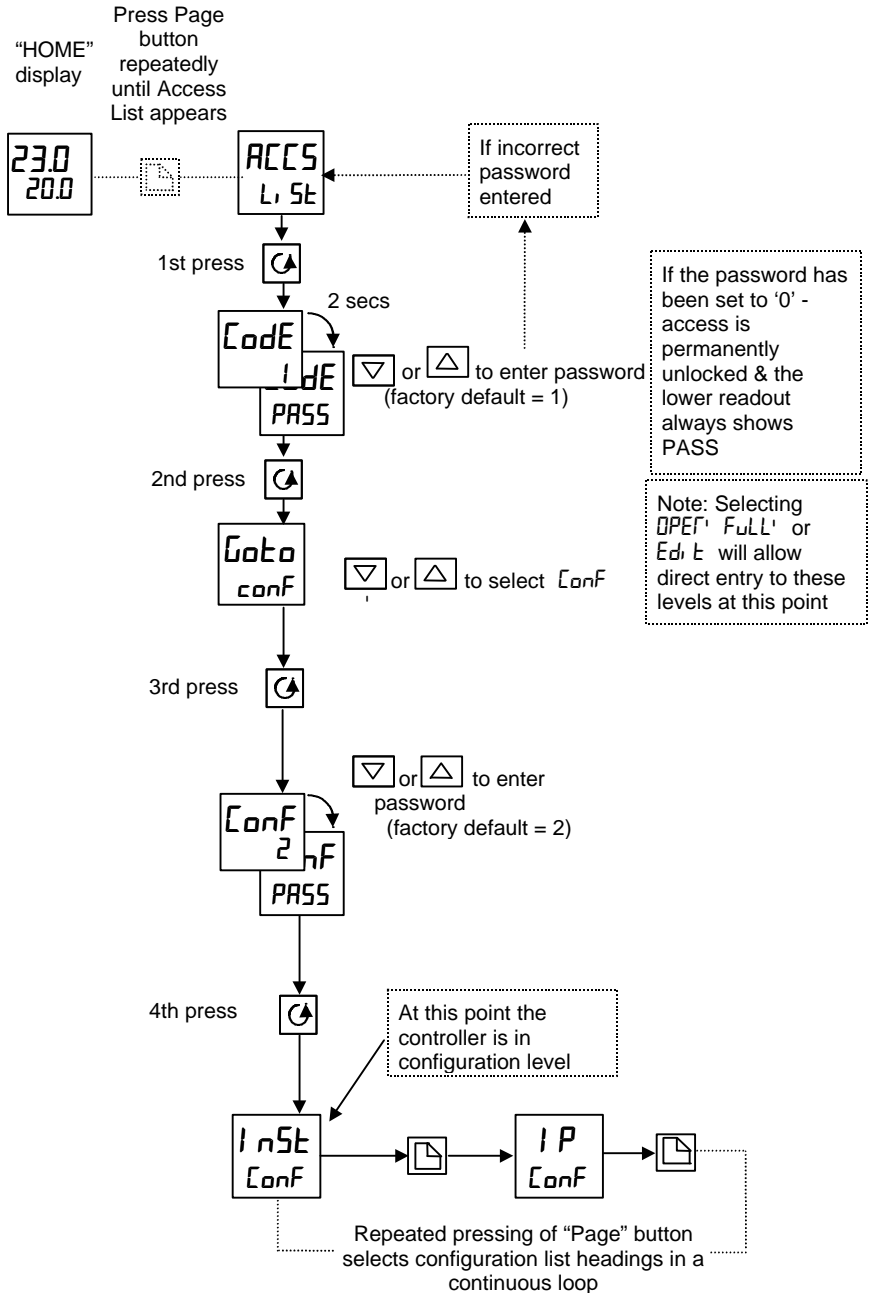

## SELECTING A CONFIGURATION PARAMETER

(continued from previous page)

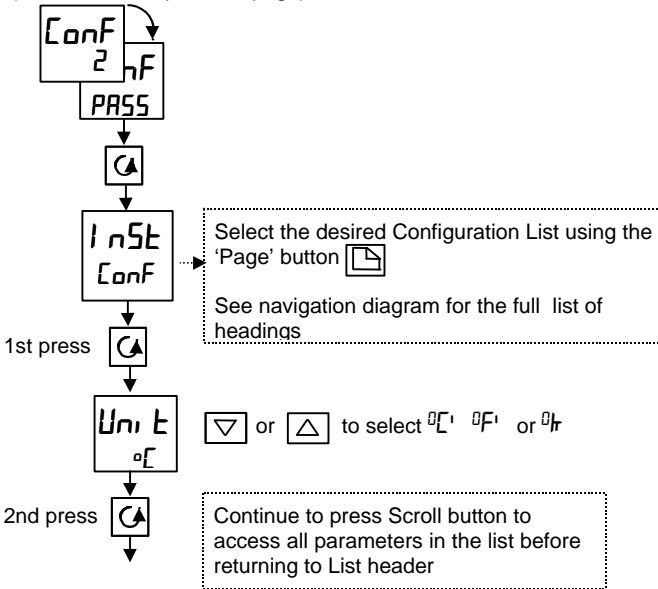

## LEAVING CONFIGURATION LEVEL

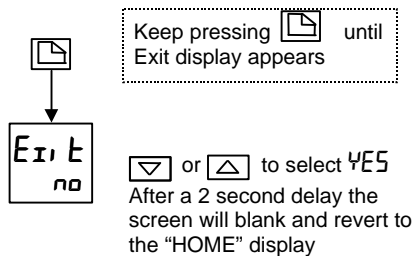

## STEPS INVOLVED IN CONFIGURING A CONTROLLER

The navigation diagram which follows shows the general location of parameters which define the way in which the controller works. They are grouped under headings.

The actual parameters shown in your controller may differ slightly since some appear only as a result of selecting others. A full list of possibilities is included in the PARAMETER TABLES which follow the navigation diagram.

**NAVIGATION DIAGRAM (PART A)**

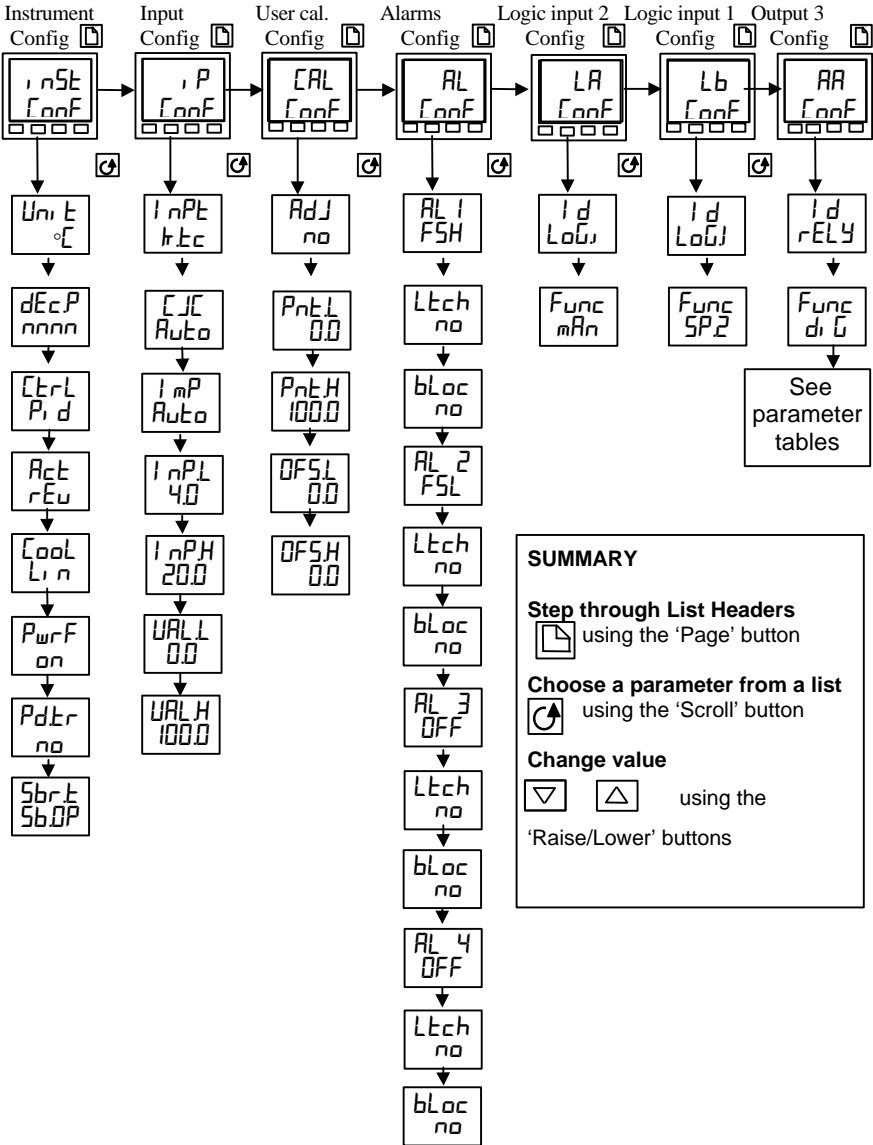
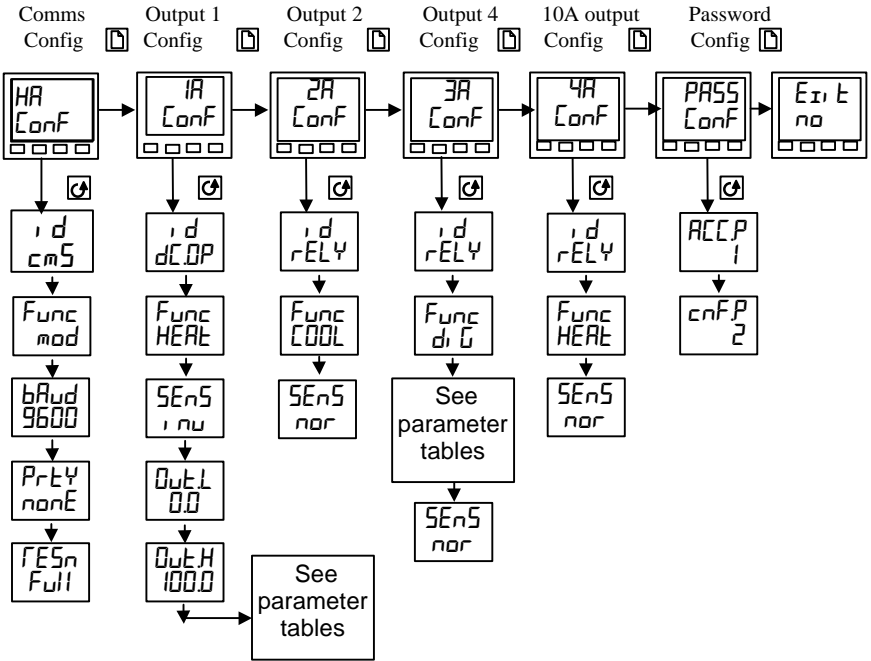

Fig 5.1a Navigation Diagram (Part A)

**NAVIGATION DIAGRAM (PART B)**



**Fig 5.1b Navigation Diagram (Part B)**

Heading	Input/Output Functions	Wiring Terminals
The first four headings set up the controller functions as follows:		
<i>Inst CONF</i>	Sets up display and control parameters	Not applicable
<i>IP CONF</i>	Selects the input sensor type	Not applicable
<i>CAL CONF</i>	To calibrate to external reference sources	Not applicable
<i>AL CONF</i>	Sets up the alarm types	Not applicable
The remaining headings configure the controller input/output functions. The upper readout corresponds to rear terminal numbers associated with a particular i/o		
<i>LA CONF</i>	Sets up the action of logic input 1	LA
<i>LB CONF</i>	Sets up the action of logic input 2	LB
<i>AA CONF</i>	Sets up the action of the relay on output 3	AA to AC
<i>HA CONF</i>	Sets up digital comms. type	HA to HF
<i>1A CONF</i>	Sets up the output 1 module	1A & 1B
<i>2A CONF</i>	Sets up the output 2 module	2A & 2B
<i>3A CONF</i>	Sets up the action of the relay on output 4	3A to 3C
<i>4A CONF</i>	Sets the action of the 10A output relay in CN2204	4A to 6D
<i>PASS CONF</i>	To choose new passwords	
<i>Exit CONF</i>	To leave configuration level and return to operator level	

**CONFIGURATION PARAMETER TABLES**

<b>Name</b>	<b>Parameter description</b>	<b>Values</b>	<b>Meaning</b>
<b>Units</b>	<b>Instrument configuration</b>		
<b>Units</b>	Instrument units	°C	Centigrade (default UK)
		°F	Fahrenheit (default USA)
		°K	Kelvin
		None	Display units will be blanked
<b>DecP</b>	Decimal places in the displayed value	None	None
		One	One
		Two	Two
<b>Ctrl</b>	Control type	On/Off	On/off control
		PID	PID control
<b>Act</b>	Control action	Rev	Reverse acting (required for temperature control) - output decreases on approach to setpoint.
		Dir	Direct acting
<b>cool</b>	Type of cooling	Lin	Linear
		Oil	Oil (50mS min on time)
		H2O	Water(non-linear)
		FAN	Fan (0.5S min on time)
<b>PwrF</b>	Power feedback	on	Power feedback is on (compensates for changes in supply voltage)
		OFF	Power feedback is off
<b>PdTr</b>	Bumpless Manual/Auto transfer when using PD control	no	Non-bumpless transfer
		YES	Bumpless transfer (auto to manual and manual to auto)
<b>Sbrt</b>	Sensor break output	Sb.OP	Go to pre-set value (maintains output at a known, safe level)
		Hold	Freeze output (maintains output at value immediately before break)

**NOTE**



Factory default parameter values and states are included where applicable and are indicated by the shaded areas in the following tables.



Name	Parameter description	Value	Meaning
------	-----------------------	-------	---------

i P i nPt	Input configuration				
		Input type	JtC KtC LtC RtC BtC NtC TtC StC PL2 rtC	J thermocouple (default USA) K thermocouple (default UK) L thermocouple R thermocouple (Pt/Pt13%Rh) B thermocouple (Pt30%Rh/Pt6%Rh) N thermocouple T thermocouple S thermocouple (Pt/Pt10%Rh) PL 2 thermocouple 100Ω platinum resistance thermometer.	
		NOTE:  <i>After selecting an input type, do not forget to adjust the setpoint limits in Full Access level</i>	CtC	Custom downloaded input type. The default is E thermocouple, or the name of the downloaded custom input will be displayed.	
			mU	Linear millivolt (Also mA input via an external 2.49Ω current sense resistor)	
			uOLt	Linear voltage	
		CJC	CJC ref. temperature  <i>(CJC does not appear for linear inputs)</i>	AutCo 0°C 45°C 50°C	Automatic cold junction compensation 0°C external reference 45°C external reference 50°C external reference
		Linear Input Scaling - The next 4 parameters only appear if a linear input is chosen			
		i nPL i nPH UALL UALH		Input value low Input value high Displayed reading low Displayed reading high	
		i mP	Sensor break input impedance trip level	OFF	Sensor break detection is disabled <i>Appears for mV or V inputs only</i>
				AutCo	Trip level set by the sensor input table
H1	Trip level set at 7.5KΩ				
H1 H1	Trip level set at 15KΩ (reqd. for i/p code 8)				

Name	Parameter description	Value	Meaning
------	-----------------------	-------	---------

CAL	User calibration config.		See Chapter 6 - User calibration
Adj	User cal enable	no	User calibration is disabled
		YES	User calibration is enabled
Pnt.L	User calibration point low	0	This is the value (in display units) at which a User last performed a low point calibration
Pnt.H	User calibration point high	100	This is the value (in display units) at which a User last performed a high point calibration
OFS.L	Low point calibration offset	0	Offset, in display units, at the user low calibration point 'Pnt.L'. This value is automatically calculated when performing low point calibration.
OFS.H	High point calibration offset	0	Offset, in display units, at the user high calibration point 'Pnt.H'. This value is automatically calculated when performing a high point calibration.

\*If User calibration is enabled, then the User calibration parameters will appear in the Input list of Operator Full access level. See Chapter 6, *User calibration*.

Name	Parameter description	Values
------	-----------------------	--------

AL	Alarm configuration	Values	Defaults if not specified
AL1	Alarm 1 Type	As table A	OFF
Ltch	Alarm 1 Latching	no' YES	no
bLoc	Alarm 1 Blocking <sup>(1)</sup>	no' YES	no
AL2	Alarm 2 Type	As table A	OFF
Ltch	Alarm 2 Latching	no' YES	no
bLoc	Alarm 2 Blocking <sup>(1)</sup>	no' YES	no
AL3	Alarm 3 Type	As table A	OFF
Ltch	Alarm 3 Latching	no' YES	no
bLoc	Alarm 3 Blocking <sup>(1)</sup>	no' YES	no
AL4	Alarm 4 Type	As table A	OFF
Ltch	Alarm 4 Latching	no' YES	no
bLoc	Alarm 4 Blocking <sup>(1)</sup>	no' YES	no

Table A: Alarm types	
OFF	No alarm
FSL	Full scale low
FSH	Full scale high
dEu	Deviation band
dHi	Deviation high
dLo	Deviation low

(1) Blocking allows the alarm to become active only after it has first entered a safe state.

**NOTE**



These are 'soft' alarms i.e. Indication only. They would normally be attached to an output. See Chapter 7 for a step by step guide.

LR	Logic input 1 configuration	Functions	Action on contact closure
i d	Identity of input	LOG1	Logic input
Func	Function	none	None
		mAn	Manual mode select
		rmt	Remote setpoint select
		SP2	Setpoint 2 select
		EH	Integral hold
		ACKAL	Acknowledge alarms
		StBY	Standby - ALL outputs = OFF
		AmPS	PDLINK load current input
Lb	Logic input 2 configuration	Functions	Action on contact closure
As per Logic input 1 except 'AmPS' not available			



Name	Parameter description	Functions	Meaning
------	-----------------------	-----------	---------

AA	Output 3 configuration	Functions	Meaning
<i>i d</i>	Identity of output	<i>rELY</i>	Relay
<i>FUNC</i>	Function	<i>nonE</i> <i>d1 G</i> <i>HEAT</i> <i>COOL</i>	None Function set by <i>d1 G</i> Heating output Cooling output
For <i>Function = d1 G</i> go to table B on the next page			
<i>SEN5</i>	Sense of output (always appears)	<i>nor</i> <i>inv</i>	Normal ( <i>heating &amp; cooling outputs</i> ) Inverted ( <i>alarms de-energized in the alarm state</i> )

HA	Comms module config	Functions	Meaning
<i>i d</i>	Identity of the option installed	<i>Pd51</i> <i>cm5</i>	PDLINK setpoint input RS-485 (EIA 485) comms module
<i>FUNC</i>	Function	<i>mod</i> <i>nonE</i>	Modbus® protocol None
<i>The following parameters will appear if the RS-485 (EIA-485) option is installed</i>			
<i>The following parameters will appear if the PDLINK setpoint input option is installed.</i>			
		<i>nonE</i> <i>SP, P</i>	No PDLINK function PDLINK setpoint input
<i>VALL</i>	PDLINK displayed value low	Range = -999 to 9999	
<i>VALH</i>	PDLINK displayed value high	Range = -999 to 9999	
<i>The following parameters will appear if the function chosen is Modbus® protocol.</i>			
<i>BAUD</i>	Baud Rate	<i>1200</i> <i>2400</i> <i>4800</i> <i>9600</i> <i>1920</i> <i>1920</i> (19200)	
<i>PRTY</i>	Comms Parity	<i>nonE</i> <i>Even</i> <i>Odd</i>	No parity Even parity Odd parity
<i>RESN</i>	Comms Resolution	<i>FULL</i> <i>INT</i>	Full resolution Integer resolution

Name	Parameter description	Function	Meaning
------	-----------------------	----------	---------

IA	Output 1 configuration	Function	Meaning
i d	Identity of module installed	nonE rELY dLOP LoG SSr	No module fitted Relay output DC output (isolated) dc pulse or PDLINK output AC SSR output
Func	Function  <i>Only appear for i d = LoG</i>	nonE dLG HEAt COOL SSr.1 SSr.2	Function set by di GF Heating output Cooling output PDLINK mode 1 heating PDLINK mode 2 heating
For Function = dLG go to table B below			
SEnS	Sense of output	nor inu	Normal (e.g. heating and cooling) Inverted (alarms - de-energize in alarm)
DC output scaling For i d = dLOP the following parameters appear			
OutL	DC output minimum	0mA to 'OutH'	
OutH	DC output maximum	'OutL' to 20mA	

Table B The following parameters appear if 'dLG' is chosen as the function.			
di GF	Digital output functions Any number of the functions listed can be combined on to the output. Use the  and  buttons to select a desired digital function. After two seconds the display will blink and return to the 'noEH' display. Use the arrows again to scroll through the function list. The previously selected function display will show two decimal points indicating that it has been added to the output.	noEH ELr 1 - - - 2 - - - 3 - - - 4 - - - Sbr Lbr LdF mAn SPAn rmtF HtrF SSrF  LdOP	No change Clear all existing functions Alarm 1* Alarm 2* Alarm 3* Alarm 4* Sensor break Loop break PDLINK Load failure Manual mode PV out of range Remote setpoint failure PDLINK Heater failure PDLINK Solid state relay failure PDLINK Load open (Amps<1)

\*In place of the dashes, the last three characters indicate the alarm type as per table A in the AL list: e.g. IFSL = Full Scale Low If an alarm is not configured the displayed name will differ: e.g. 'AL 1' will be shown, for the first alarm

Name	Parameter description	Function	Meaning
------	-----------------------	----------	---------

2A	Output 2 configuration	Function	Meaning
id	Identity of module installed	none	No module fitted
		RELAY	Relay output
		LOG	dc pulse output
Func	Function	SSR	AC SSR output
		none	none
		dl G	Function set by dl G
Func	Function	HEAT	Heating output
		COOL	Cooling output

For Func = dl G go to table B below

SEnS	Sense of output	nor inu	Normal (heat and cool outputs) Inverted (alarms - de-energize in alarm)
------	-----------------	------------	---

Table B The following parameters appear if 'dl G' is chosen as the function			
dl GF	Digital output functions Any number of the functions listed can be combined onto the output. Use the ▼ and ▲ buttons to select a desired digital function. After two seconds the display will blink and return to the 'noCH' display. Use the arrows again to scroll through the function list. The previously selected function display will show two decimal points indicating that it has been added to the o/p	noCH	No change
		CLR	Clear all existing functions
		1 - - -	Alarm 1*
		2 - - -	Alarm 2*
		3 - - -	Alarm 3*
		4 - - -	Alarm 4*
		Sbr	Sensor break
		Lbr	Loop break
		LdF	PDLINK Load failure
		mAN	Manual mode
		SPAn	PV out of range
		rmtF	Remote setpoint failure
		Ht rF	PDLINK Heater failure
		SSrF	PDLINK Solid state relay failure
Ldop	PDLINK Load open (Amps<1)		

\*In place of the dashes, the last three characters indicate the alarm type: e.g. **IFSL**  
If alarm not configured displayed name will differ: e.g. **AL 1** will be shown, for 1st alarm

3A	Output 4 configuration	As per output 3 configuration
----	------------------------	-------------------------------

4A	10Amp heating output	Available on CN2204 only.
As per Output 3 'AA' relay configuration		

PASS	Password list
ALLP	FuLL or Edit level password (default = 1)
cnFP	Configuration level Password (default = 2)

EXIT	Exit Configuration	no YES
------	--------------------	--------

## Chapter 6 USER CALIBRATION

This chapter has five topics:

- WHAT IS THE PURPOSE OF USER CALIBRATION?
- USER CALIBRATION ENABLE
- SINGLE POINT CALIBRATION
- TWO POINT CALIBRATION
- CALIBRATION POINTS AND CALIBRATION OFFSETS

To understand how to select and change parameters in this chapter you will need to have read Chapter 1 - *Operation*, Chapter 3- *Access Levels* and Chapter 5 - *Configuration*.

### WHAT IS THE PURPOSE OF USER CALIBRATION?

The basic calibration of the controller is highly stable and set for life. User calibration allows you to offset the 'permanent' factory calibration to either:

1. Calibrate the controller to your reference standards
2. Match the calibration of the controller to that of a particular transducer or sensor input
3. Calibrate the controller to suit the characteristics of a particular installation.

User calibration works by introducing zero and span offsets onto the factory set calibration. The factory set calibration can always be retrieved.

## USER CALIBRATION ENABLE

The User calibration facility must first be enabled in configuration level by setting the parameter 'Adj' in the `CAL CONF` list to 'YES'. This will make the User calibration parameters appear in Operator 'FULL' level.

Select configuration level as shown in Chapter 5, Configuration

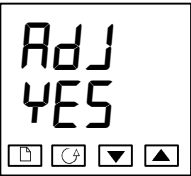

### The User calibration configuration List



Press  until you reach the 'CAL CONF' list

*Press the Scroll button until you reach*



### User calibration enable

Use  or  to select:

- YES: Calibration enable
- NO: Calibration disabled

Press  and  together to go to the Exit display

### Exit configuration

Use  or  to select 'YES' and return to Operator level.



### SINGLE POINT CALIBRATION

Your controller is calibrated for life against known reference sources during manufacture. A calibration offset is often used to allow the controller to compensate for sensor and other system errors. The normal procedure is to set up the system under test against a known independent reference, as follows:

Set up the process to be calibrated such that the known reference displays the required value (temperature).

Observe the reading on the controller. If it is different, proceed as follows:

Select 'FULL' Access level as described in Chapter 3

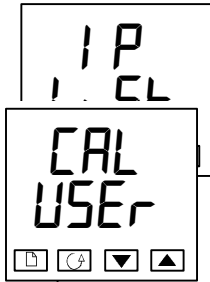



#### Input list header

Press  until you reach the input list header.

*Press Scroll until you reach the 'CAL' display*

#### Calibration type

Use  or  to select either 'FACT' or 'USER'.

Selecting 'FACT' will reinstate the factory calibration and hide the following User calibration parameters.

Selecting 'USER' will reinstate any previously set User calibration and make available the User parameters, as follows:

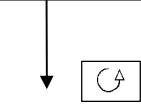

*Press the Scroll button*

#### Calibrate low point?

Use  or  to select 'YES'.



Selecting 'no' will hide the next parameter

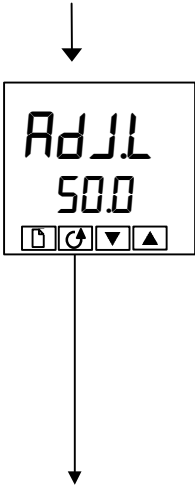



### Adjust the low point calibration



The controller will display the current measured input value in the lower readout.

Use  or  to adjust the reading to the reference source value, if different.

After a two-second delay the display will blink and the reading will change to the new, calibrated value. You can calibrate at any point over the entire display range

This is a single point calibration, which applies a fixed offset over the full display range of the controller.

The calibration is now complete. You can return to the factory calibration at any time by selecting 'FACT' in the CAL display shown earlier.

Press  and  together to return to the Home display

To protect the calibration against unauthorized adjustment return to Operator level and make sure that the calibration parameters are hidden. Parameters are hidden using the 'Edt' facility described in Chapter 3.

## TWO POINT CALIBRATION

The previous section described how to perform a single point calibration, which applies a fixed offset over the full display range of the controller. A two-point calibration is used to calibrate the controller at two points and apply a straight line between them. Any readings above or below the two calibration points will be an extension of this straight line. For this reason it is best to calibrate with the two points as far apart as possible.

Proceed as follows:

1. Decide upon the low and high points at which you wish to calibrate.
2. Perform a single point calibration at the low calibration point in the manner described above
3. Set the process under calibration such that the known reference displays the required higher Process Value (temperature) and allow to stabilize.
4. Press the Scroll button to obtain the high calibration point as shown in the following diagrams.

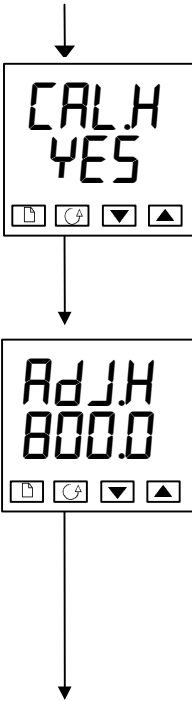

**Calibrate high point?**

Use or to select 'YES'  
(Selecting 'no' will hide the next parameter)

*Press the Scroll button*

**Adjust the high point calibration**

The controller will display the current measured input value in the lower readout.

Use or to adjust the reading to the reference source value, if different.

After a two-second delay the display will blink and the reading will change to the new, calibrated value.

The calibration is now complete. You can return to the factory calibration at any time by selecting 'FACT' in the CAL display shown earlier.

*Press and together to return to the Home display*

To protect the calibration against unauthorized adjustment, return to Operator level and make sure that the calibration parameters are hidden. Parameters are hidden using the 'Edit' facility described in Chapter 3.

**CALIBRATION POINTS AND CALIBRATION OFFSETS**

If you wish to see the points at which the User calibration was performed and the value of the offsets introduced these are shown in Configuration, under CAL CONF. The parameters are:

Name	Parameter description	Meaning
PntL	User low calibration point	This is the value (in display units) at which a User last performed an 'AdLL' (adjust low calibration).
PntH	User high calibration point	This is the value (in display units) at which a User last performed an 'AdjH' (adjust high calibration).
OfsL	Low point calibration offset	Offset, in display units, at the user low calibration point 'PntL'
OfsH	High point calibration offset	Offset, in display units, at the user high calibration point 'PntH'



---

## Chapter 7 ALARM CONFIGURATION

	PAGE
<b>Definition of Alarms and Events .....</b>	<b>7-2</b>
<b>Types of Alarms .....</b>	<b>7-2</b>
<b>Configuring the Four ‘Soft’ Alarms.....</b>	<b>7-4</b>
<b>Attaching an Alarm to a Physical Output .....</b>	<b>7-5</b>
<b>Grouping Alarms on a Single Output .....</b>	<b>7-6</b>
<b>Removing Alarms from an Output .....</b>	<b>7-6</b>

The CN2208 and CN2204 controllers are capable of very sophisticated alarm strategies and, although setting up of alarms has already been covered in previous chapters, this section has been included to enable operators and commissioning engineers to design their own strategies for optimum plant operation.

## DEFINITION OF ALARMS AND EVENTS

**Alarms** are used to alert an operator when a pre-set level or condition has been exceeded. They are normally used to switch an output - usually a relay - to provide interlocking of the machine or plant or external audio or visual indication of the condition.

**Soft Alarms** are indication only within the controller and are not attached to an output (relay).

**Events** - can also be alarms - but are generally defined as conditions, which occur as part of the normal operation of the plant. They do not generally require operator intervention. An example might be to open/close a vent during a programmer cycle. Events are referred to as **Digital Output Functions** in the manual see pages 5-11 and 5-12.

For the purposes of the operation of this instrument alarms and events can be considered the same.

## TYPES OF ALARMS

The use of alarms in your controller is extremely versatile.

Up to 4 alarms can be configured and they are found under the Alarm List in Full Access Mode. Any combination of these 4 alarms can be attached to any one or more outputs. NOTE: in a three-term controller at least one of these outputs is used to maintain the required temperature of the process.

OR any number of the available “soft” alarms can be combined to operate a single output

Outputs 1 and 2	Are plug in modules. Conventionally used for control outputs, e.g. Heat and Cool, but can be used for alarms.
Output 3	Is a fixed relay. Conventionally used for alarms or events, but can be used as a control output.

There are five process alarm types listed below. Alarm Types are found in configuration mode under the Alarm Config. List.

## ALARMS

<b>Full Scale High</b>	The PV exceeds a set high level
<b>Full Scale Low</b>	The PV exceeds a set low level
<b>Deviation Band</b>	The difference between PV & SP is outside a set band
<b>Deviation High</b>	The difference between PV & SP is higher than a set level
<b>Deviation Low</b>	The difference between PV & SP is lower than a set level

Each **alarm** can be set to:

<b>Latching</b>	Alarm is indicated until acknowledged
<b>Blocking</b>	Alarm occurs <b>after</b> it has been through a start up phase
<b>Sense Of Output</b>	Relay energized or de-energized in alarm condition

In addition there are nine “digital output functions” used as events or alarms depending upon the requirements of the process under control:

## DIGITAL OUTPUT FUNCTIONS

<b>Sensor Break</b>	The input is open circuit
<b>Loop Break</b>	The controller does not measure a response to an output change
<b>Load Failure</b>	Used with PDLINK partial load failure
<b>Manual</b>	Controller in manual mode
<b>PV Out Of Range</b>	Process Variable too high or too low
<b>Remote SP Fail</b>	No signal measured at the remote set point input terminals
<b>Heater Fail</b>	Used with PDLINK heater open circuit
<b>Solid State Relay Fail</b>	Used with PDLINK solid state relay open or short circuit
<b>Load Open</b>	Used with PDLINK no connection at the control output

The **Sense of the Output** can be set to relay energized or de-energized in the alarm condition for any of the above functions.

### STEP1 - CONFIGURING THE FOUR 'SOFT' ALARMS

Go To Configuration Level  
Refer to Chapter 5

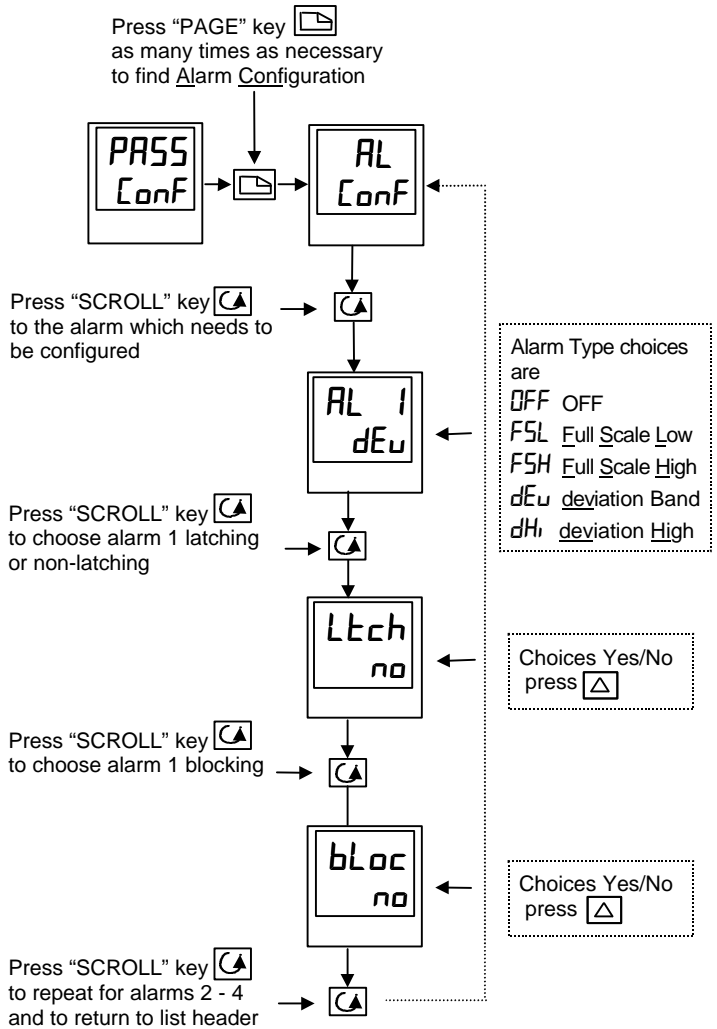



## STEP 2 - ATTACHING AN ALARM TO A PHYSICAL OUTPUT

This may be necessary if:

1. The instrument has been supplied un-configured or it is required to re-configure
2. Alarm relays are added

The “AA” output given is for example only. Alarms may be attached to any available output (1A, 2A, etc.)

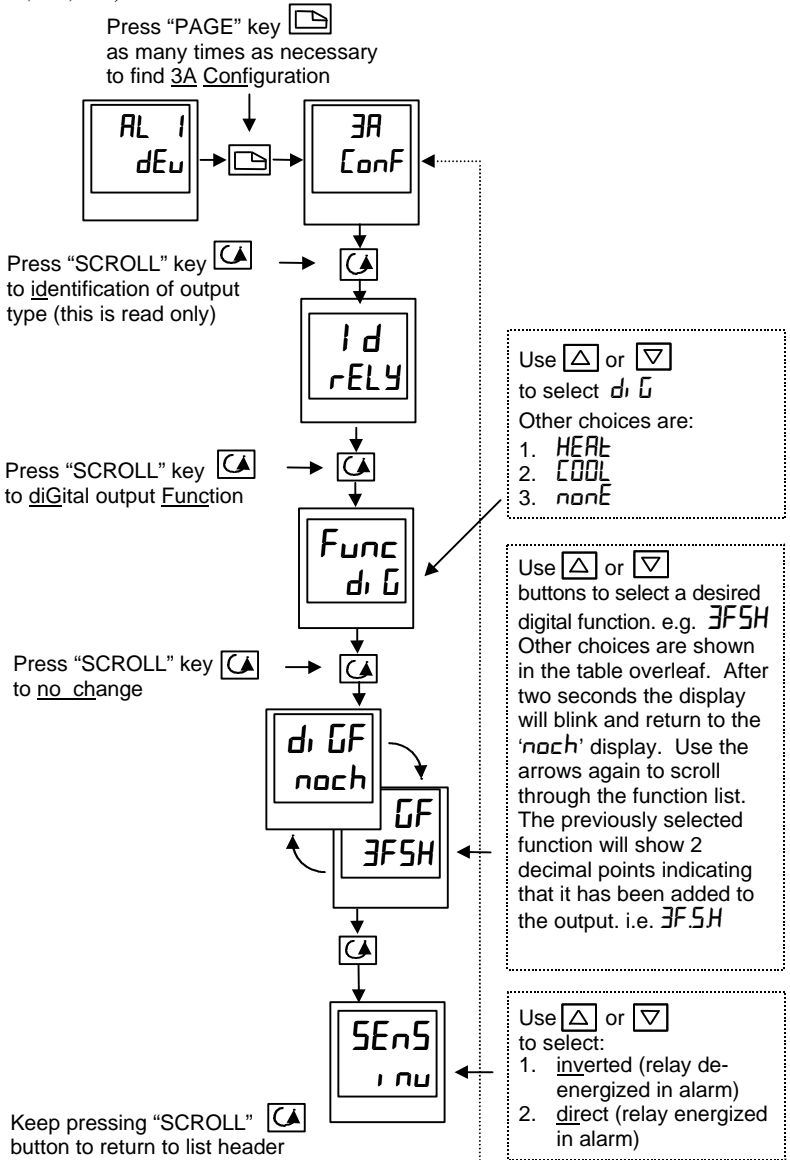

### STEP 3 - GROUPING ALARMS ON A SINGLE OUTPUT

In the previous example one alarm condition is allocated to one output relay.

The CN2208 and CN2204 controllers allow alarms and events to be grouped on to a single output. These events are shown in the table below.

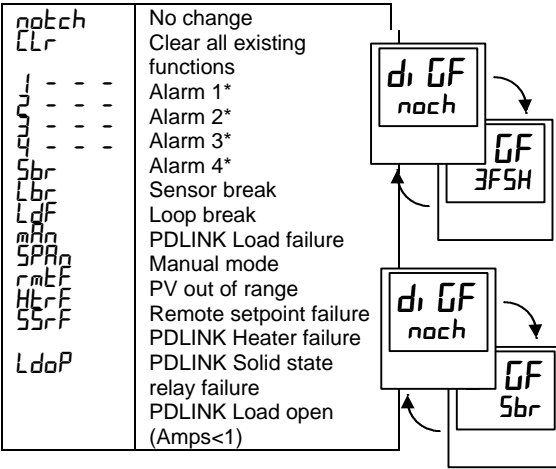

Press until you reach the 1<sup>st</sup> soft alarm you wish to attach to an output e.g. 3F5H  
The display returns to no change after 2 sec. accepting the condition.

Press until you reach the 2<sup>nd</sup> soft alarm you wish to attach to the output e.g. 5br  
The display returns to no change after 2 sec. accepting the condition.

Repeat for all alarms to be attached to the chosen output

Each time you scroll through the table of alarms note that two decimal points appear confirming acceptance that the particular alarm has been attached to the output. i.e. 3F5H 5br etc.

### STEP 4 - REMOVING ALARMS FROM AN OUTPUT

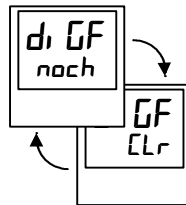

Press once to show clear  
After 2 sec. the lower readout reverts to no change clearing all events from the chosen output.

# Appendix A

## UNDERSTANDING THE ORDERING CODE

<b>To Order (Specify Model Number)</b>	
<b>Single Output Models</b>	
<b>Model Number</b>	<b>Single Output Type</b>
CN2216-R1	1/16 DIN controller, Relay Output
CN2216-F1	1/16 DIN controller, 4-20 mA Output
CN2216-D1	1/16 DIN controller, dc Pulse Output
CN2216-T1	1/16 DIN controller, ac SSR Output
CN2208-R1	1/8 DIN controller, Relay Output
CN2208-F1	1/8 DIN controller, 4-20 mA Output
CN2208-D1	1/8 DIN controller, dc Pulse Output
CN2208-T1	1/8 DIN controller, ac SSR Output
CN2204-R1	1/4 DIN controller, Relay Output
CN2204-F1	1/4 DIN controller, 4-20 mA Output
CN2204-D1	1/4 DIN controller, dc Pulse Output
CN2204-T1	1/4 DIN controller, ac SSR Output
<b>Dual Output Models (Refer to Output Options for Dual output Models)</b>	
CN2216-(*)-(**)	1/16 DIN controller, 85 to 264 Vac Power
CN2208-(*)-(**)	1/8 DIN controller, 85 to 264 Vac Power
CN2204-(*)-(**)	1/4 DIN controller, 85 to 264 Vac Power

*Ordering Example: CN2204-R1-T2-A2-C4-HC, dual output controller with one relay output, one ac SSR output, dual alarms, RS-485 (EIA-485) Communications, high current output voltage.*

*\* Specify Output 1, \*\* Specify Output 2*

<b>Output Options for Dual Output Models</b>		
<b>Output Type</b>	<b>Output 1(*) Order Suffix</b>	<b>Output 2(**) Order Suffix</b>
Relay	-R1	-R2
0-20 mA, 0-10 Vdc*	-F1	N/A
dc Pulse	-D1	-D2
ac SSR	-T1	-T2

\*Note: 0-10 Vdc (when used with supplied shunt resistor)

<b>Alarms and Communication Options</b>	
<b>Model Number</b>	<b>Description</b>
-A1*	Single alarm
-A2*	Dual alarm (not available on CN2216)
-C4	2-Wire RS-485 (EIA-485) communications

\*Note: One alarm option may be ordered

<b>High Current Output (CN2204 Only)</b>	
<b>Model Number</b>	<b>Description</b>
-HC	High current output

<b>Field Installable Output Modules</b>	
<b>Model Number</b>	<b>Description</b>
BD2200-R	Relay output module
BD2200-D	dc Pulse output module
BD2200-T	ac SSR output module
BD2200-F	Isolated 0-20mA/0-10 V output module
BD2200-HC	High current relay output module (CN2204 only)

<b>Accessories</b>	
<b>Model Number</b>	<b>Description</b>
SSC-TE10S*	Solid State Contactor
CNQUENCHARC	Noise Suppression Kit, 110-230 Vac

\*To order, refer to the SSC-TE10S specification sheet

**Notes:**

1. **PDLINK** is a proprietary technique for bi-directional communication over a single pair of wires. There are several operating modes.  
  
In **mode 1** a DC pulse output delivers a power demand signal to a SSC-TE10S solid state (SSR) relay and the SSR responds with a single load circuit failure message.  
  
In **mode 2** a DC pulse output delivers a power demand signal to an SSC-TE10S and the SSR responds with the ON state rms load current, and two fault messages - SSR failure or heater circuit failure.
2. **Range min and Range max:** Enter a numeric value, with a decimal point if required. Thermocouple and RTD sensor inputs will always display over the full operating range shown in the sensor input table. The values entered here will act as low and high setpoint limits. For linear inputs, the values entered are used to scale the input signal.



## Appendix B

### SAFETY and EMC INFORMATION

This controller is intended for industrial temperature and process control applications when it will meet the requirements of the European Directives on Safety and EMC. Use in other applications, or failure to observe the installation instructions of this handbook may impair safety or EMC. The installer must ensure the safety and EMC of any particular installation.

#### **Safety**

This controller complies with the European Low Voltage Directive 73/23/EEC, amended by 93/68/EEC, by the application of the safety standard EN 61010.

#### **Electromagnetic compatibility**

This controller conforms to the essential protection requirements of the EMC Directive 89/336/EEC, amended by 93/68/EEC, by the application of a Technical Construction File. This instrument satisfies the general requirements of the industrial environment defined in EN 50081-2 and EN 50082-2. For more information on product compliance refer to the Technical Construction File.

#### **GENERAL**

The information contained in this manual is subject to change without notice. While every effort has been made to ensure the accuracy of the information, Omega shall not be held liable for errors contained herein.

#### **Unpacking and storage**

The packaging should contain an instrument mounted in its sleeve, two mounting brackets for panel installation and this operating book. Certain ranges are supplied with an input adapter.

If on receipt, the packaging or the instrument is damaged, do not install the product but contact Omega.

If the instrument is to be stored before use, protect from humidity and dust in an ambient temperature range of  $-30^{\circ}\text{C}$  to  $+75^{\circ}\text{C}$ .

#### **SERVICE AND REPAIR**

This controller has no user serviceable parts. Contact Omega for repair.

#### **Caution: Charged capacitors**

Before removing an instrument from its sleeve, disconnect the supply and wait at least two minutes to allow capacitors to discharge. It may be convenient to partially withdraw the instrument from the sleeve, then pause before completing the removal. In any case, avoid touching the exposed electronics of an instrument when withdrawing it from the sleeve. Failure to observe these precautions may cause damage to components of the instrument or some discomfort to the user.

## Electrostatic discharge precautions

When the controller is removed from its sleeve, some of the exposed electronic components are vulnerable to damage by electrostatic discharge from someone handling the controller. To avoid this, before handling the unplugged controller discharge yourself to ground.

## Cleaning

Do not use water or water based products to clean labels or they will become illegible. Isopropyl alcohol may be used to clean labels. A mild soap solution may be used to clean other exterior surfaces of the product.

# INSTALLATION SAFETY REQUIREMENTS

## Safety Symbols

Various symbols are used on the instrument; they have the following meaning:



Caution, (refer to the accompanying documents)



Functional earth (ground) terminal

The functional earth connection is not required for safety purposes but to ground RFI filters.

## Personnel

Installation must only be carried out by qualified personnel.

## Enclosure of live parts

To prevent hands or metal tools touching parts that may be electrically live; the controller must be installed in an enclosure.

## Caution: Live sensors

The dc pulse and PDLINK outputs are electrically connected to the main PV input, (thermocouple etc.). If the temperature sensor is connected directly to an electrical heating element then these non-isolated inputs and outputs will also be live. The controller is designed to operate under these conditions. However you must ensure that this will not damage other equipment connected to these inputs and outputs and that service personnel do not touch connections to these i/o while they are live. With a live sensor, all cables connectors and switches for connecting the sensor and non-isolated inputs and outputs must be mains rated. The dc output has a 42V functional insulation to PV.

## Wiring

It is important to connect the controller in accordance with the wiring data given in this handbook. Take particular care not to connect AC supplies to the low voltage sensor input or other low level inputs and outputs. Only use copper conductors for connections, (except thermocouple). Ensure that the wiring of installations comply with all local wiring regulations. For example in the in the UK use the latest version of the IEE wiring regulations, (BS7671). In the USA use NEC Class 1 wiring methods.



**Power Isolation**

The installation must include a power isolating switch or circuit breaker that disconnects all current carrying conductors. The device should be mounted in close proximity to the controller, within easy reach of the operator and marked as the disconnecting device for the instrument.

**Earth leakage current**

Due to RFI Filtering there is an earth leakage current of less than 0.5mA. This may affect the design of an installation of multiple controllers protected by Residual Current Device, (RCD) or Ground Fault Detector, (GFD) type circuit breakers.

**Overcurrent protection**

To protect the internal PCB tracking within the controller against excess currents, the AC power supply to the controller and power outputs must be wired through the fuse or circuit breaker specified in the technical specification.

**Voltage rating**

The maximum continuous voltage applied between any connection to ground must not exceed 264Vac.

The controller should not be wired to a three-phase supply with an unearthed star connection. Under fault conditions such a supply could rise above 264Vac with respect to ground and the product would not be safe.

Voltage transients across the power supply connections, and between the power supply and ground, must not exceed 2.5kV. Where occasional voltage transients over 2.5kV are expected or measured, the power installation to both the instrument supply and load circuits should include a transient limiting device.

These units will typically include gas discharge tubes and metal oxide varistors that limit and control voltage transients on the supply line due to lightning strikes or inductive load switching. Devices are available in a range of energy ratings and should be selected to suit conditions at the installation.

**Conductive pollution**

Electrically conductive pollution must be excluded from the cabinet in which the controller is mounted. For example, carbon dust is a form of electrically conductive pollution. To secure a suitable atmosphere, install an air filter to the air intake of the cabinet. Where condensation is likely, for example at low temperatures, include a thermostatically controlled heater in the cabinet.

**Grounding of the temperature sensor shield**

In some installations it is common practice to replace the temperature sensor while the controller is still powered up. Under these conditions, as additional protection against electric shock, we recommend that the shield of the temperature sensor be grounded. Do not rely on grounding through the framework of the machine.

### **Over-temperature protection**

When designing any control system it is essential to consider what will happen if any part of the system should fail. In temperature control applications the primary danger is that the heating will remain constantly on. Apart from spoiling the product, this could damage any process machinery being controlled or even cause a fire.

Reasons why the heating might remain constantly on include:

- the temperature sensor becoming detached from the process
- thermocouple wiring becoming short circuit;
- the controller failing with its heating output constantly on
- an external valve or contactor sticking in the heating condition
- the controller setpoint set too high.

Where damage or injury is possible, we recommend fitting a separate over-temperature protection unit, with an independent temperature sensor, which will isolate the heating circuit.

Please note that the alarm relays within the controller will not give protection under all failure conditions.

### **INSTALLATION REQUIREMENTS FOR EMC**

To ensure compliance with the European EMC directive certain installation precautions are necessary as follows:

- When using relay or AC SSR outputs it may be necessary to fit a filter suitable for suppressing the conducted emissions. The filter requirements will depend on the type of load.
- If the unit is used in tabletop equipment, which is plugged into a standard power socket, then it is likely that compliance to the commercial and light industrial emissions standard is required. In this case to meet the conducted emissions requirement, a suitable line filter should be installed.

### **Routing of wires**

To minimize the pick-up of electrical noise, the low voltage DC connections and the sensor input wiring should be routed away from high-current power cables. Where it is impractical to do this, use shielded cables with the shield grounded at both ends. In general keep cable lengths to a minimum.

## TECHNICAL SPECIFICATION

### Environmental ratings

Panel sealing:	Instruments are intended to be panel mounted. The rating of panel sealing is IP65, (EN 60529), or 4X, (NEMA 250).
Operating temperature:	0 to 55°C. Ensure the enclosure provides adequate ventilation.
Relative humidity:	5 to 95%, non-condensing.
Atmosphere:	Not suitable for use above 2000m or in explosive or corrosive atmospheres.

### Equipment ratings

Supply voltage / frequency:	100 to 240Vac -15%, +10% / 48 to 62Hz.
Power consumption:	10Watts maximum.
Relay (isolated):	Maximum: 264Vac, 2A resistive. Minimum: 12Vdc, 100mA.
AC SSR output (isolated):	30 to 264Vac. Maximum current: 1A resistive.
High current switch: (CN2204)	30 to 264Vac. Maximum current: 10A resistive. (isolated)
Leakage current:	External 'snubber' components are supplied to suppress voltage spikes on AC SSR and relay contact outputs. The leakage current through these components is less than 2mA at 264Vac, 50Hz.
Over current protection:	Use a minimum of 0.5mm <sup>2</sup> or 16awg wire for plant connections. External over current protection devices is required. Use independent fuses for the instrument supply and each relay or AC SSR output. Suitable fuses are time-lag, (EN60127, type T) with ratings as follows; Instrument supply and relay outputs: 2A; AC SSR outputs: 1A, High current switch: 10A.
Low level I/O:	Input and output connections other than AC SSR and relay are intended for low level signals less than 42V.
dc pulse output (non-isolated):	18V at 24mA.
DC output (isolated *):	0 to 20mA (600Ω max), 0 to 10V (500Ω min) (*see isolation).
PDLINK input (isolated):	Setpoint input from and holdback to a master PDLINK controller.
Digital communications:	RS-232 (EIA-232) or, 2-wire RS-485 (EIA-485), (both isolated).

### Electrical safety

Safety Standard:	Meets EN 61010, Installation category II, pollution degree 2. Voltage transients on any mains power connected to the instrument must not exceed 2.5kV. Electrically conductive pollution must be excluded from the cabinet in which the instrument is mounted.
Isolation:	All inputs and outputs have reinforced insulation to provide protection against electric shock. The logic and PDLINK outputs are electrically connected to the main PV input, (thermocouple etc.). The dc output has a 42V functional insulation to PV.

