

omega.com®

Ω OMEGA®

# Super MCJ

SMCJ-J, SMCJ-K, SMCJ-T

Thermocouple Input (SMP or OST Connectors)

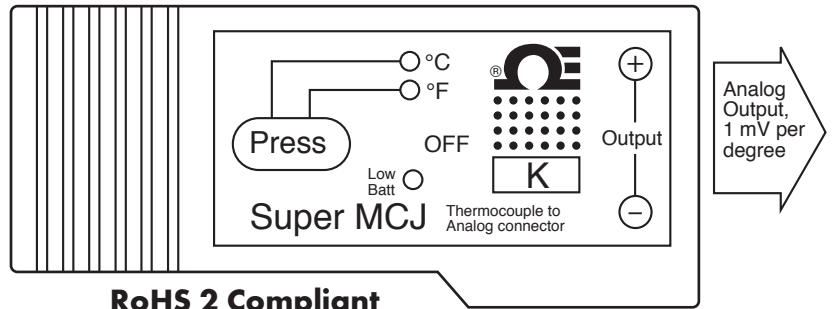

RoHS 2 Compliant

## Thermocouple-to-Analog Connector

INSTRUCTION SHEET

M2813-0103

Shop online at: [omega.com](http://omega.com) e-mail: [info@omega.com](mailto:info@omega.com)  
For latest product manuals: [omegamanual.info](http://omegamanual.info)

### GENERAL DESCRIPTION

This is a Thermocouple to Analog Connector. It converts a thermocouple input signal (Type J, K, or T) to a linear, compensated, amplified analog output. The unit provides 1mV/°F or 1mV/°C analog output. The analog output can go to a strip chart recorder or a digital voltmeter for temperature monitoring.

The unit is powered by a single AA size lithium battery. In order to install the battery, remove the back cover and place the battery on the PC board. The battery polarity is indicated on the PC board. If the battery is installed reverse, the unit will not power up. The back cover is mounted to the front cover via two mounting holes.

The input connection can be SMP or OST type connections. The output connection is standard banana plug or jack. The plastic case and the rubber gasket Bumper Band® provides a rugged and sealed connector design. Figure 1 provides a functional flow chart of how the unit operates. This unit is operated using a single tactile feedback button **Press**.

There are 3 LEDs built into the connector. The °C green LED flashes once every 2 seconds when the output provides 1mV/°C. The °F green LED flashes once every 2 seconds when the output provides 1mV/°F. If the input is open the °C and °F green LEDs

both flash alternately once a second.

When the battery voltage drops below a certain level, a red LED starts to flash once a second. This is a low battery indication. The battery must be replaced with a fresh battery immediately.

#### Field Adjustments

The unit is field adjustable by removing the back cover and accessing the three potentiometers. R17 provides offset adjustment when the unit is in mV/°F mode. R42 provides offset adjustment when the unit is in mV/°C mode. R32 provides span (gain) adjustment either in mV/°F or mV/°C mode.

### SPECIFICATIONS

#### Measuring Temperature Range:

Type J: -100 to +750°C (-148 to +1382°F)  
Type K: -100 to +1250°C (-148 to +2282°F)  
Type T: -100 to +350°C (-148 to +662°F)

#### Accuracy @ 75°F ambient temperature across the range:

Type J: ±1.4°C (±2.5°F)  
Type K: ±3°C (±5°F)  
Type T: ±2°C (±3°F)

**Input Connection:** SMP or OST connector

**Input Impedance:** 3M-ohms

**Output Connection:** Standard Banana Plug or Jack

#### Thermocouple Break Protection:

Output goes Upscale (std.)  
°F & °C Green LEDs flash once a second

**Output:** 1mV/°F or 1mV/°C, °F or °C Green LEDs flash once every 2 seconds

**Output Load:** 1K-Ohms min.

**Power:** One AA size Lithium Battery, 3.4 to 3.6 VDC 1900 mAh

#### Battery Life @ 75°F Ambient Temperature:

1440 hours (60 Days), continuous, no load

#### Low Battery Indication:

Red LED flashes once a second,

#### Response Time:

(0 to 63% of Final value): 150 msec

#### Operating Temperature:

0 to 50°C (32 to 122°F)

#### Thermal Zero Drift:

0.05 mV/°C (0.05 mV/°F) ambient temperature change

#### Operating Relative Humidity:

95% or less, without condensation

#### Dimensions:

4"L x 2"W x 1"H (10L x 5W x 2.5H cm)

**Weight:** 2.4 oz (67g)

### OTHER IMPORTANT CONSIDERATIONS BEFORE OPERATION

#### CAUTION

⚠ Follow all the safety precautions and operating instructions outlined in the manual.

⚠ The installation category is one (1).

⚠ There are no user replaceable fuse in this product.

⚠ Maximum input voltage to earth: 30 Vrms (42.4 peak) or 60 Vdc.

⚠ Avoid contact with hazardous live parts. The thermocouple probe should not be connected to hazardous live voltages (less than max. input voltage to earth).

⚠ The output terminals of this product are

for use with equipment (digital multimeter, chart recorder, etc.) which have no accessible live parts. Such equipment should comply with all the applicable safety requirements.

⚠ Do not open batteries, dispose of in fire, heat above 100°C (212°F), expose contents to water, recharge, put in backwards, mix with used or other battery types. It may cause explosion, leakage or personal injury.

⚠ Use cloth dampened with warm water and soap to clean the outside case and label. Do not use flammable liquid solutions for cleaning. Do not immerse the product in water.

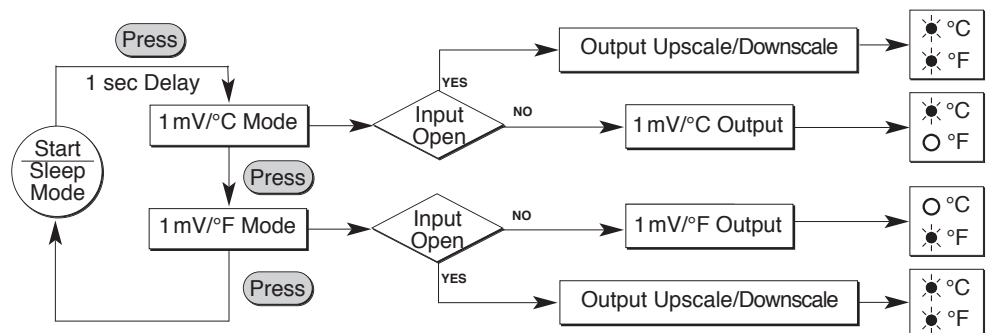

Figure 1, Functional Flow Chart

### Accessories

Model No.	Description
OM-NOMAD-BATT	Replacement Battery
SMCJ-CAB	Cable Wire (Red & Black) 36" Long



OMEGAnet® Online Service omega.com	Internet e-mail info@omega.com
---------------------------------------	-----------------------------------

**Servicing North America:**

**U.S.A.:** Omega Engineering, Inc., One Omega Drive, P.O. Box 4047  
ISO 9001 Certified Stamford, CT 06907-0047  
Toll-Free: 1-800-826-6342 Tel: (203) 359-1660  
FAX: (203) 359-7700 e-mail: info@omega.com

**Canada:** 976 Bergar  
Laval (Quebec), H7L 5A1 Canada  
Toll-Free: 1-800-826-6342 TEL: (514) 856-6928  
FAX: (514) 856-6886 e-mail: info@omega.ca

**For immediate technical or application assistance:**

**U.S.A. and Canada:** Sales Service: 1-800-826-6342 / 1-800-TC-OMEGA®  
Customer Service: 1-800-622-2378 / 1-800-622-BEST®  
Engineering Service: 1-800-872-9436 / 1-800-USA-WHEN®

**Mexico/ Latin America** En Español: 001 (203) 359-7803 FAX: 000 (203) 359-7807  
info@omega.com.mx e-mail: espanol@omega.com

**Servicing Europe:**

**Benelux:** Managed by the United Kingdom Office  
Toll-Free: 0800 099 3344 TEL: +31 20 347 21 21  
FAX: +31 20 643 46 43 e-mail: sales@omegaeng.nl

**Czech Republic:** Frystatska 184  
733 01 Karviná, Czech Republic  
Toll-Free: 0800-1-66342 TEL: +420-59-6311899  
FAX: +420-59-6311114 e-mail: info@omegashop.cz

**France:** Managed by the United Kingdom Office  
Toll-Free: 0800 466 342 TEL: +33 (0) 161 37 29 00  
FAX: +33 (0) 130 57 54 27 e-mail: sales@omega.fr

**Germany/Austria:** Daimlerstrasse 26, D-75392 Deckenpfronn, Germany  
Toll-Free: 0800 6397678 TEL: +49 (0) 7056 9398-0  
FAX: +49 (0) 7056 9398-29 e-mail: info@omega.de

**United Kingdom:** OMEGA Engineering Ltd.  
ISO 9001 Certified One Omega Drive, River Bend Technology Centre, Northbank  
Irlam, Manchester M44 5BD United Kingdom  
Toll-Free: 0800-488-488 TEL: +44 (0) 161 777-6611  
FAX: +44 (0) 161 777-6622 e-mail: sales@omega.co.uk

It is the policy of OMEGA Engineering, Inc. to comply with all worldwide safety and EMC/EMI regulations that apply. OMEGA is constantly pursuing certification of its products to the European New Approach Directives. OMEGA will add the mark to every appropriate device upon certification.

The information contained in this document is believed to be correct, but OMEGA accepts no liability for any errors it contains, and reserves the right to alter specifications without notice. **WARNING:** These products are not designed for use in, and should not be used for, human applications.

**WARRANTY/DISCLAIMER**

OMEGA ENGINEERING, INC. warrants this unit to be free of defects in materials and workmanship for a period of **13 months** from date of purchase. OMEGA's WARRANTY adds an additional one (1) month grace period to the normal **one (1) year product warranty** to cover handling and shipping time. This ensures that OMEGA's customers receive maximum coverage on each product.

If the unit malfunctions, it must be returned to the factory for evaluation. OMEGA's Customer Service Department will issue an Authorized Return (AR) number immediately upon phone or written request. Upon examination by OMEGA, if the unit is found to be defective, it will be repaired or replaced at no charge. OMEGA's WARRANTY does not apply to defects resulting from any action of the purchaser, including but not limited to mishandling, improper interfacing, operation outside of design limits, improper repair, or unauthorized modification. This WARRANTY is VOID if the unit shows evidence of having been tampered with or shows evidence of having been damaged as a result of excessive corrosion; or current, heat, moisture or vibration; improper specification; misapplication; misuse or other operating conditions outside of OMEGA's control. Components in which wear is not warranted, include but are not limited to contact points, fuses, and triacs.

**OMEGA is pleased to offer suggestions on the use of its various products. However, OMEGA neither assumes responsibility for any omissions or errors nor assumes liability for any damages that result from the use of its products in accordance with information provided by OMEGA, either verbal or written. OMEGA warrants only that the parts manufactured by the company will be as specified and free of defects. OMEGA MAKES NO OTHER WARRANTIES OR REPRESENTATIONS OF ANY KIND WHATSOEVER, EXPRESSED OR IMPLIED, EXCEPT THAT OF TITLE, AND ALL IMPLIED WARRANTIES INCLUDING ANY WARRANTY OF MERCHANTABILITY AND FITNESS FOR A PARTICULAR PURPOSE ARE HEREBY DISCLAIMED. LIMITATION OF LIABILITY: The remedies of purchaser set forth herein are exclusive, and the total liability of OMEGA with respect to this order, whether based on contract, warranty, negligence, indemnification, strict liability or otherwise, shall not exceed the purchase price of the component upon which liability is based. In no event shall OMEGA be liable for consequential, incidental or special damages.**

**CONDITIONS:** Equipment sold by OMEGA is not intended to be used, nor shall it be used: (1) as a "Basic Component" under 10 CFR 21 (NRC), used in or with any nuclear installation or activity; or (2) in medical applications or used on humans. Should any Product(s) be used in or with any nuclear installation or activity, medical application, used on humans, or misused in any way, OMEGA assumes no responsibility as set forth in our basic WARRANTY/DISCLAIMER language, and, additionally, purchaser will indemnify OMEGA and hold OMEGA harmless from any liability or damage whatsoever arising out of the use of the Product(s) in such a manner.

**RETURN REQUESTS / INQUIRIES**

Direct all warranty and repair requests/inquiries to the OMEGA Customer Service Department. **BEFORE RETURNING ANY PRODUCT(S) TO OMEGA, PURCHASER MUST OBTAIN AN AUTHORIZED RETURN (AR) NUMBER FROM OMEGA'S CUSTOMER SERVICE DEPARTMENT (IN ORDER TO AVOID PROCESSING DELAYS).** The assigned AR number should then be marked on the outside of the return package and on any correspondence.

The purchaser is responsible for shipping charges, freight, insurance and proper packaging to prevent breakage in transit.

FOR **WARRANTY** RETURNS, please have the following information available BEFORE contacting OMEGA:

1. Purchase Order number under which the product was PURCHASED,
2. Model and serial number of the product under warranty, and
3. Repair instructions and/or specific problems relative to the product.

FOR **NON-WARRANTY** REPAIRS, consult OMEGA for current repair charges. Have the following information available BEFORE contacting OMEGA:

1. Purchase Order number to cover the COST of the repair,
2. Model and serial number of the product, and
3. Repair instructions and/or specific problems relative to the product.

OMEGA's policy is to make running changes, not model changes, whenever an improvement is possible. This affords our customers the latest in technology and engineering. OMEGA is a registered trademark of OMEGA ENGINEERING, INC.

© Copyright 2011 OMEGA ENGINEERING, INC. All rights reserved. This document may not be copied, photocopied, reproduced, translated, or reduced to any electronic medium or machine-readable form, in whole or in part, without the prior written consent of OMEGA ENGINEERING, INC.