

1 YEAR
WARRANTY

MADE IN
USA



User's Guide

Shop online at

omega.com[®]

Ω OMEGA[®]

omega.com

e-mail: info@omega.com

For latest product manuals:

omegamanual.info

ISO 9001
CERTIFIED
CORPORATE QUALITY
STAMFORD, CT

ISO 9001
CERTIFIED
CORPORATE QUALITY
MANCHESTER, UK



HX94A SERIES **RH/Temperature Transmitter**



OMEGAnet® Online Service omega.com	Internet e-mail info@omega.com
---	---

Servicing North America:

U.S.A.: Omega Engineering, Inc., One Omega Drive, P.O. Box 4047
ISO 9001 Certified Stamford, CT 06907-0047
Toll-Free: 1-800-826-6342 Tel: (203) 359-1660
FAX: (203) 359-7700 e-mail: info@omega.com

Canada: 976 Bergar
Laval (Quebec), Canada H7L 5A1
Toll-Free: 1-800-826-6342 TEL: (514) 856-6928
FAX: (514) 856-6886 e-mail: info@omega.com

For immediate technical or application assistance:

U.S.A. and Canada: Sales Service: 1-800-826-6342/1-800-TC-OMEGA®
Customer Service: 1-800-622-2378/1-800-622-BEST®
Engineering Service: 1-800-872-9436/1-800-USA-WHEN®

Mexico: En Español: 001 (203) 359-7803 FAX: (001) 203-359-7807
info@omega.com.mx e-mail: espanol@omega.com

Servicing Europe:

Benelux: Managed by the United Kingdom Office
Toll-Free: 0800 099 3344 TEL: +31 20 347 21 21
FAX: +31 20 643 46 43 e-mail: sales@omega.nl

Czech Republic: Frystatska 184
733 01 Karviná, Czech Republic
Toll-Free: 0800-1-66342 TEL: +420-59-6311899
FAX: +420-59-6311114 e-mail: info@omegashop.cz

France: Managed by the United Kingdom Office
Toll-Free: 0800 466 342 TEL: +33 (0) 161 37 29 00
FAX: +33 (0) 130 57 54 27 e-mail: sales@omega.fr

Germany/Austria: Daimlerstrasse 26
D-75392 Deckenpfronn, Germany
Toll-Free: 0 800 6397678 TEL: +49 (0) 7059 9398-0
FAX: +49 (0) 7056 9398-29 e-mail: info@omega.de

United Kingdom: OMEGA Engineering Ltd.
ISO 9001 Certified One Omega Drive, River Bend Technology Centre, Northbank
Irlam, Manchester M44 5BD England
Toll-Free: 0800-488-488 TEL: +44 (0)161 777-6611
FAX: +44 (0)161 777-6622 e-mail: sales@omega.co.uk

It is the policy of OMEGA Engineering, Inc. to comply with all worldwide safety and EMC/EMI regulations that apply. OMEGA is constantly pursuing certification of its products to the European New Approach Directives. OMEGA will add the CE mark to every appropriate device upon certification.

The information contained in this document is believed to be correct, but OMEGA accepts no liability for any errors it contains, and reserves the right to alter specifications without notice.

WARNING: These products are not designed for use in, and should not be used for, human applications.

HX94A SERIES RH/Temperature Transmitter

TABLE OF CONTENTS

Section	Page
1. General Description	1
2. Unpacking	1
3. Theory of Operation	2
4. Mounting	3
5. Electrical Connections	4
6. Wiring Examples	5
7. Relative Humidity Output Calculations	5
8. RH Measured Vs Output Reading Table	6
9. Temperature Output Calculations	6
10. Calibration	6
11. Calibration Procedure For HX94AC Relative Humidity Adjustment	7
12. Calibration Procedure For HX94AC Temperature Adjustment	8
13. Calibration Procedure For HX94AV Relative Humidity Adjustment	9
14. Calibration Procedure For HX94AV Temperature Adjustment	10
15. Maintenance	11
16. Specifications	12
17. General Specifications	13

Figure		Page
Figure 1	Basic Transmitter Set-up With Current Loop Output	2
Figure 2	Dimensions	3
Figure 3	Mounting	3
Figure 4	Current Transmitter Wiring Example (4 - 20 mA)	5
Figure 5	Voltage Transmitter Wiring Example (0 - 1 Vdc).....	5
Figure 6	HX94AC Calibration Procedure Relative Humidity Adjustment	7
Figure 7	HX94AC Calibration Procedure Temperature Adjustment	8
Figure 8	HX94AV Calibration Procedure Relative Humidity Adjustment	9
Figure 9	HX94AV Calibration Procedure Temperature Adjustment	10
Figure 10	Sensor Filter Cap Removal	11

1. General Description

The OMEGA® HX94A Series Relative Humidity/Temperature Transmitter's provide a linearized and temperature compensated output signal of 4 to 20 mA or 0 to 1 Vdc depending upon the model selected for both relative humidity and temperature measurement. The output signals have been calibrated and scaled 0 to 100% for Relative Humidity and 0 to 100°C (32 to 212°C) for temperature. A thin film polymer capacitor senses relative humidity while an 100 ohm RTD measures temperature, both are protected by a stainless steel filter that is easily removed for cleaning. The Nema-4 stainless steel enclosure and cable entry connection provides weathertight protection.

2. Unpacking

Remove the packing list and verify that you have received all your equipment. If you have any questions about the shipment, please call our Customer Service Department at:

1-800-622-2378 or 203-359-1660. On the web you can find us at:
omega.com **e-mail: cservice@omega.com**

When you receive the shipment, inspect the container and equipment for any signs of damage. Note any evidence of rough handling in transit. Immediately report any damage to the shipping agent.

NOTE

The carrier will not honor any damage claims unless all shipping material is saved for inspection. After examining and removing contents, save packing material and carton in the event reshipment is necessary.

The following items are supplied in the box with your HX94A transmitter.

- This Manual, # M2750A (1 ea.)
- Wall/Duct Mounting Kit (1 ea.)
- 4-Pin Mating Connector; with connector models only (1ea.)
- Dewpoint Card (1 ea.)

Additional Transmitter Models Available

Model Description

HX94AC RH/Temperature Transmitter (4 to 20 mA Output) with 4 Pin Connector.

HX94AV RH/Temperature Transmitter (0 - 1 Vdc Output) with 4 Pin Connector.

HX94ACW RH/Temperature Transmitter (4 to 20 mA Output) with 1 m (3') lead wires.

- HX94AVW, RH/Temperature Transmitter (0 - 1 Vdc Output) with 1 m (3') lead wires.
- HX94ACNPT RH/Temperature Transmitter (4 to 20 mA Output) with 1/2" male NPT fitting and 1 m (3') lead wires.
- HX94AVNPT RH/Temperature Transmitter (0 - 1 Vdc Output) with 1/2" male NPT fitting and 1 m (3') lead wires.

3. Theory of Operation

A 4-20 mA loop is a series loop in which a transmitter will vary the current flow depending on the input to the transmitter. In the HX94A Series the amount of current allowed to flow in the loop will vary depending on the relative humidity or temperature being measured by the sensor(s). Some advantages of a current output over a voltage output is that the signal measured is less susceptible to electrical noise interference and the loop can support more than one measuring instrument as long as the maximum loop resistance is not exceeded.

A typical application utilizing a current loop will normally consist of a power supply, the transmitter and a meter, recorder or controller to measure the current flow. The loop resistance in the sum of the measuring instruments and wire used. The maximum allowable loop resistance for the HX94A to function properly is found by using the following formula:

$$R_{\max} = (\text{power supply voltage} - 6 \text{ volts}) \div 0.02 \text{ amps}$$

EXAMPLE: (When using a 24 Vdc power supply).

$$R_{\max} = (24 - 6) \div 0.02 \text{ amps} = 900 \text{ ohms max loop resistance}$$

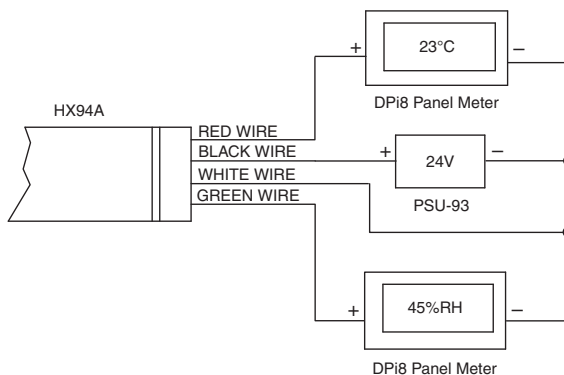

Figure 1 - Basic Transmitter Set-up With Voltage Output

Complimentary Instruments

Unregulated 16 -23 Vdc Power Supply, OMEGA® Part No.: PSU-93
Regulated 24 Vdc Power Supply, OMEGA® Part No.: PSR-24L
iSeries® Panel Meters and Controllers

Recommended Accessories

Shielded Transmitter Cable, OMEGA® Part No.: TX4-100 (100 ft)
RH Calibration Kit, OMEGA® Part No.: HX92-CAL
Spare 4 pin mating connector, OMEGA® Part No.: HX94-MC

4. Mounting

OMEGA's HX94A transmitter's are designed for either wall or duct mounting. A wall/duct mounting kit is included with each unit.

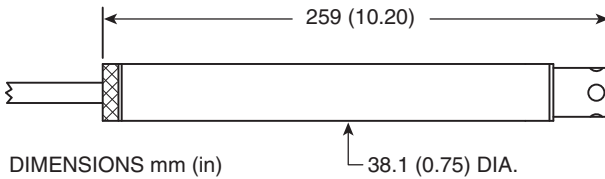

Figure 2 - HX94A Dimensions

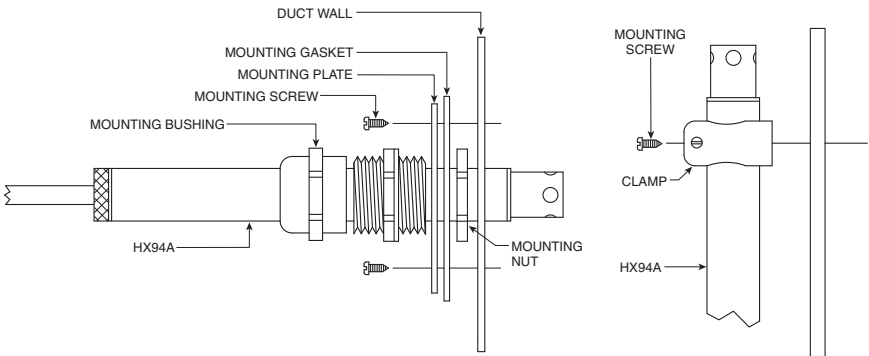

Figure 3 - HX94A Mounting

5. Electrical Connections

CAUTION

All electrical connections and wiring should be performed by a suitably trained professional only.

Models: HX94AC
(2-Wire Current Output with connector)
Temperature

Pin #2. + Power Supply

Pin #3. 4-20 mA Output

Connector Body: Shield, Earth Ground

Relative Humidity

Pin #1. + Power Supply

Pin #4. 4-20 mA Output

Models: HX94ACW, HX94ACNPT
(2-Wire Current Output with stripped leads)
Temperature

White Wire: + Power Supply

Red Wire: 4-20 mA Output

Bare Wire: Shield, Earth Ground

Relative Humidity

Black Wire: + Power Supply

Green Wire: 4-20 mA Output

Models: HX94AV
(3-Wire Voltage Output with connector)
Temperature

Pin #1. + Power Supply

Pin #3. 0 - 1 Vdc Output

Pin #2. - Power Supply

Connector Body: Shield, Earth Ground

Relative Humidity

Pin #1. + Power Supply

Pin #4. 0 - 1 Vdc Output

Pin #2. - Power Supply

Models: HX94AVW, HX94AVNPT
(3-Wire Voltage Output with stripped leads)
Temperature

Black Wire: + Power Supply

Red Wire: 0 - 1 Vdc Output

White Wire: - Power Supply

Bare Wire: Shield, Earth Ground

Relative Humidity

Black Wire: + Power Supply

Green Wire: 0 - 1 Vdc Output

White Wire: - Power Supply

6. Wiring Examples

For current output models (4 to 20 mA)

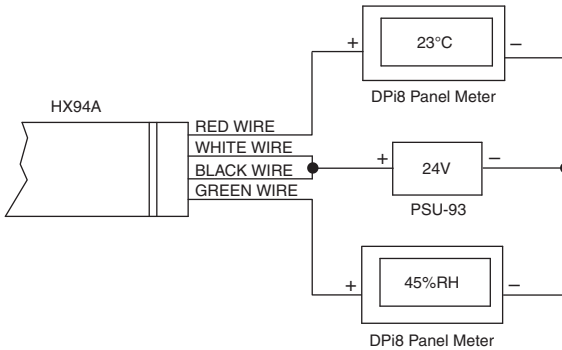

Figure 4 - Current Transmitter Wiring Example

For voltage output models (0 to 1 Vdc)

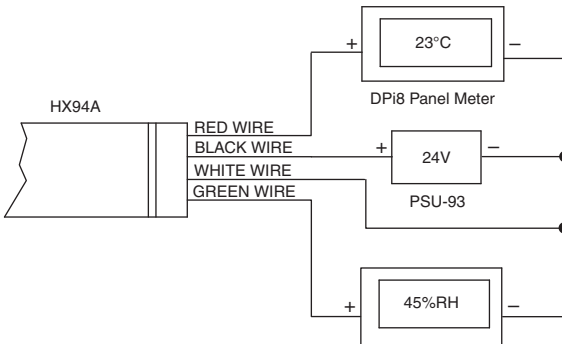

Figure 5 - Voltage Transmitter Wiring Example

7. Relative Humidity Output Calculations

To calculate % Relative Humidity by measuring the current or voltage output use the following formulas.

For current output:

$$\% \text{ RH} = (\text{Current measured in miliamps} - 4) \div 0.16$$

EXAMPLE: $(11.04 \text{ mA} - 4) \div 0.16 = 44\% \text{ RH}$

For voltage output:

$$\% \text{ RH} = (\text{Voltage measured in volts} \times 100)$$

EXAMPLE: $0.44 \times 100 = 44\% \text{ RH}$

8. RH Measured Vs Output Reading Table

% Relative Humidity	Output	
	Current (mA)	Voltage (Vdc)
5	4.8	0.05
10	5.6	0.10
15	6.4	0.15
20	7.2	0.20
25	8.0	0.25
30	8.8	0.30
35	9.6	0.35
40	10.4	0.40
45	11.2	0.45
50	12.0	0.50
55	12.8	0.55
60	13.6	0.60
65	14.4	0.65
70	15.2	0.70
75	16.0	0.75
80	16.8	0.80
85	17.6	0.85
90	18.4	0.90
95	19.2	0.95

9. Temperature Output Calculations

To calculate Temperature by measuring the current or voltage output use the following formulas.

For Current output in °C (0 to 100°C)

$$^{\circ}\text{C} = (\text{Output measured in miliamps} - 4) \div 0.16 = ^{\circ}\text{C}$$

EXAMPLE: (8.0 mA - 4) \div 0.16 = 25°C

For Current output °F (32 to 212°F)

$$^{\circ}\text{F} = (\text{Output measured in miliamps} - 4) \div 0.08888 + 32 = ^{\circ}\text{F}$$

EXAMPLE: (8.0 mA - 4) \div 0.08888 + 32 = 77°F

For Voltage output in °C (0 to 100°C)

$$^{\circ}\text{C} = (\text{Output measured in volts} \div 0.10) = ^{\circ}\text{C}$$

EXAMPLE: (0.25 Vdc \div 0.10) = 25°C

For Voltage output °F (32 to 212°F)

$$^{\circ}\text{F} = (\text{Output measured in volts} \div 0.005555) + 32 = ^{\circ}\text{F}$$

EXAMPLE: (0.25 Vdc \div 0.005555) + 32 = 77°F

10. Calibration

Your transmitter has been factory calibrated to meet or exceed the specifications outlined in this manual. To maintain original specifications it is generally recommended that your transmitter be recalibrated on an annual basis depending on operating conditions.

11. Calibration Procedure for HX94AC (all styles)

Relative Humidity Adjustment

Recommended equipment:

- RH Calibration Kit, OMEGA® Model No.: HX92-CAL
- Handheld Digital Multi-meter, OMEGA® Model No.: HHM29B
- Unregulated DC Power Supply, OMEGA® Model No.: PSU-93 or Regulated DC Power Supply, OMEGA® Model No.: PSR-24L

1. Remove sensor head and main electronics boards from the stainless steel housing.
2. Connect transmitter as shown in the figure below.
3. Apply power to transmitter and allow to warm up for 10 min.
4. Place the sensor head into the 11% RH calibration bottle as shown and allow the readings to stabilize for 10 min.
5. Adjust potentiometer "P1" for an output reading of 5.76 mA.
6. Place the sensor head into the 75% RH calibration bottle and allow the readings to stabilize for 10 min.
7. Adjust potentiometer "P2" for an output reading of 16.0 mA.
8. Repeat steps 4, 5, 6, 7 as necessary until proper readings are maintained.
9. Reinstall the sensor head and main electronics back into the stainless steel housing.
10. Calibration complete.

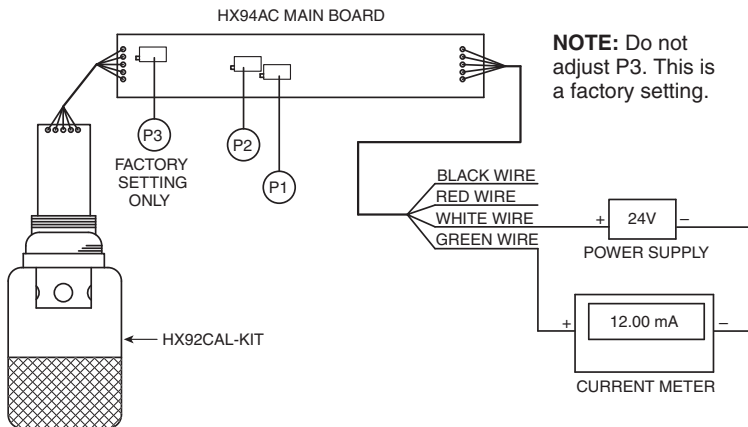

Figure 6 - HX94AC Calibration Procedure
Relative Humidity Adjustment

12. Calibration Procedure for HX94AC

Temperature Adjustment

Recommended equipment:

- Thermistor Temperature Meter, OMEGA® Model No.: HH41
 - Thermistor Probe, OMEGA® Model No.: ON-403-PP
 - Handheld Digital Multi-meter, OMEGA® Model No.: HHM29B
 - Unregulated DC Power Supply, OMEGA® Model No.: PSU-93 or Regulated DC Power Supply, OMEGA® Model No.: PSR-24L
1. Remove sensor head and main electronics boards from the stainless steel housing.
 2. Connect transmitter as shown in figure below.
 3. Apply power to transmitter and allow unit to warm up for 10 min.
 4. Place a precision temperature meter/probe like the recommended HH41 meter and ON-403-PP probe next to the sensor head of your HX94A. Record the ambient temperature measured by the precision meter/probe.
 5. Based on the ambient temperature that you measured in step 4, calculate what the correct "Output Setting" should be for your HX94A.

Use one of these two formulas:

Ambient Temperature (°C) x (16/100) + 4 = Output Setting

Example: (22°C) x (0.16) + 4 = 7.52 mA

Ambient Temperature (°F - 32) x (16/180) + 4 = Output Setting

Example: (72°F - 32) x (0.0888) + 4 = 7.55 mA

6. Adjust potentiometer "P4" for the correct output reading from your HX94A you calculated in step 5.
7. Calibration complete.

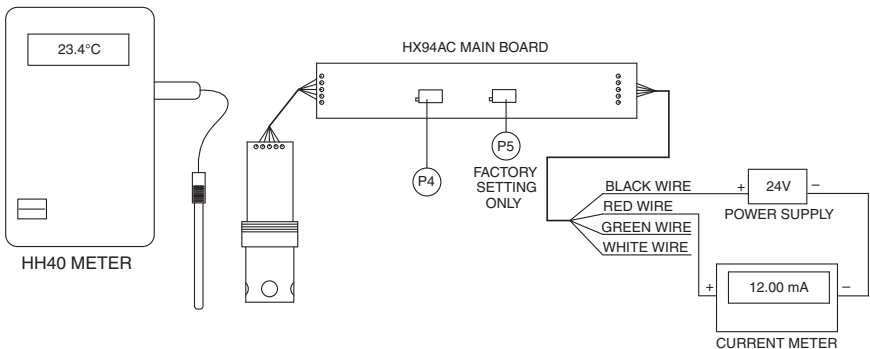

Figure 7 - HX94AC Calibration Procedure
Temperature Adjustment

13. Calibration Procedure for HX94AV

Relative Humidity Adjustment

Recommended equipment:

- Humidity Calibration Kit, OMEGA® Model No.: HX92-CAL
- Handheld Digital Multi-meter, OMEGA® Model No.: HHM29B
- Unregulated DC Power Supply, OMEGA® Model No.: PSU-93 or Regulated DC Power Supply, OMEGA® Model No.: PSR-24L

1. Remove sensor head and main electronics boards from the stainless steel housing.
2. Connect transmitter as shown in figure below.
3. Apply power to transmitter and allow to warm up for 10 min.
4. Place the sensor head into the 11% RH calibration bottle as below and allow the readings to stabilize for 10 min.
5. Adjust potentiometer "P3" for an output reading of 0.110 Vdc.
6. Place the sensor head into the 75% RH calibration bottle and allow the readings to stabilize for 10 min.
7. Adjust potentiometer "P2" for an output reading of 0.750 Vdc.
8. Repeat steps 4, 5, 6, 7 as necessary until proper readings are maintained.
9. Reinstall the sensor head and main electronics back into the stainless steel housing.
10. Calibration complete.

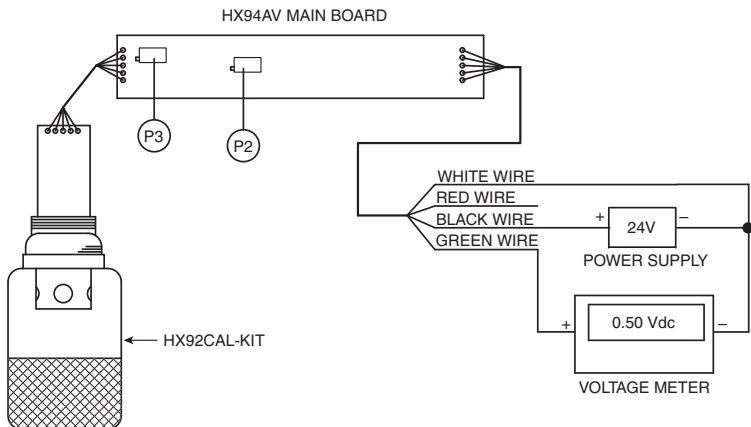

Figure 8 - HX94AV Calibration Procedure
Relative Humidity Adjustment

14. Calibration Procedure for HX94AV

Temperature Adjustment

Recommended equipment:

- Thermistor Temperature Meter, OMEGA® Model No.: HH41
- Thermistor Probe, OMEGA® Model No.: ON-403-PP
- Handheld Digital Multi-meter, OMEGA® Model No.: HHM29B
- Unregulated DC Power Supply, OMEGA® Model No.: PSU-93 or Regulated DC Power Supply, OMEGA® Model No.: PSR-24L

1. Remove sensor head and main electronics boards from the stainless steel housing.
2. Connect transmitter as shown in figure below.
3. Apply power to transmitter and allow unit to warm up for 10 min.
4. Place a precision temperature meter/probe like the recommended HH41 meter and ON-403-PP probe next to the sensor head of your HX94A. Record the ambient temperature measured by the meter/probe.
5. Based on the ambient temperature that you measured in step 4., calculate what the correct "Output Setting" should be for your HX94A.

Use one of these two formulas:

Ambient Temperature (°C) x (1/100) = Output Setting

Example: 22°C x 0.010 = 0.220 Vdc

Ambient Temperature (°F - 32) x (1/180) = Output Setting

Example: (72°F - 32) x (0.0888) + 4 = 7.55 mA

6. Adjust potentiometer "P4" for the correct output reading from your HX94A you calculated in step 5.
7. Calibration complete.

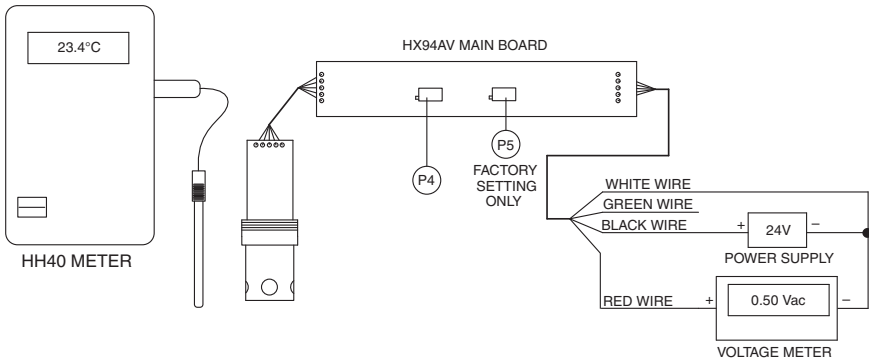

Figure 9 - HX94AV Calibration Procedure
Temperature Adjustment

15. Maintenance

If your Humidity transmitter will be used in a dusty environment, the protective sensor filter, if clogged, may be removed for cleaning. Unscrew the protective cover and gently blow compressed air through the filter screen. A soft brush may also be used to remove dirt particles from the screen.

If the sensor is subjected to 100% condensation, it must be dried to obtain correct readings. There will be no permanent damage or calibration shift to the unit.

Units should not be exposed to high concentrations of ammonia or alcohol vapors.

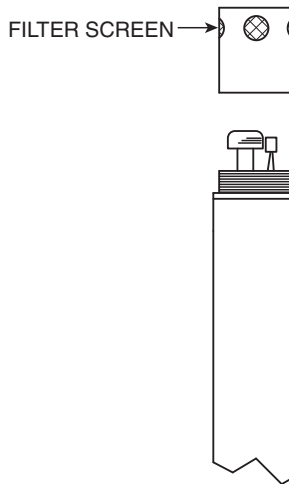

Figure 10 - Sensor Filter Cap Removal

16. Specifications

Relative Humidity

Measuring Range:	3 - 95% (non-condensing)
Accuracy:	±2.5% @ 22°C (72°F) from 20 to 80% RH; ±3.1% @ 22°C (72°F) below 20 and above 80% RH; with an added temperature coefficient error of ±0.1% RH/°F (both increasing and decreasing in temperature).
Repeatability:	± 1 % RH
Operating Temperature Range:	0 to 100°C (32 to 212°F)
Output:	
Model: HX94AC	4 to 20 mA (Scaled for 0 to 100% RH)
Model : HX94AV	0 to 1 Vdc (Scaled for 0 to 100% RH)
Power:	6 -30 Vdc @ 20mA
Max Loop Resistance:	Ohms = (V supply - 6 V)/0.02 A
Max Output Load:	200 Ohms (Voltage models)
RH Time Constant (90% response at 25°C, in moving air at 1m/s):	>10 seconds, 10 to 90% RH >15 seconds, 90 to 10% RH
Sensor Type:	Thin Film Polymer Capacitor

Temperature

Measuring Range:	0 to 100°C (32 to 212°F)
Accuracy:	±0.6°C (1°F)
Repeatability:	± 0.3°C (0.5°F)
Output:	
Model: HX94AC4 to	20 mA, Scaled 0 to 100°C (32 to 212°F)
Model : HX94AV	0 to 1 Vdc, Scaled 0 to 100°C (32 to 212°F)
Power:	12 - 30 Vdc @ 30mA
Max Loop Resistance:	Ohms = (V supply - 6 V)/0.02 A
Sensor Type:	100 Ohm Platinum RTD

17. General Specifications

Enclosure Housing:	316 Stainless Steel, Nema-4
Electrical Connections HX94AC, HX94AV:	1 m (3') 4-conductor shielded PVC cable with connector termination. 4 pin mating connector included that accepts 26 to 18 AWG wire.
HX94ACW, HX94AVW, HX94ACNPT HX94AVNPT:	1 m (3') 4 conductor , shielded PVC cable with stripped lead termination.
Dimensions:	See "Mounting" Section
Weight (with mounting kit)	200 g. (7 oz)



HX94A SERIES
RH/Temperature Transmitter

NOTES:



WARRANTY/DISCLAIMER

OMEGA ENGINEERING, INC. warrants this unit to be free of defects in materials and workmanship for a period of **13 months** from date of purchase. OMEGA's WARRANTY adds an additional one (1) month grace period to the normal **one (1) year product warranty** to cover handling and shipping time. This ensures that OMEGA's customers receive maximum coverage on each product.

If the unit malfunctions, it must be returned to the factory for evaluation. OMEGA's Customer Service Department will issue an Authorized Return (AR) number immediately upon phone or written request. Upon examination by OMEGA, if the unit is found to be defective, it will be repaired or replaced at no charge. OMEGA's WARRANTY does not apply to defects resulting from any action of the purchaser, including but not limited to mishandling, improper interfacing, operation outside of design limits, improper repair, or unauthorized modification. This WARRANTY is VOID if the unit shows evidence of having been tampered with or shows evidence of having been damaged as a result of excessive corrosion; or current, heat, moisture or vibration; improper specification; misapplication; misuse or other operating conditions outside of OMEGA's control. Components in which wear is not warranted, include but are not limited to contact points, fuses, and triacs.

OMEGA is pleased to offer suggestions on the use of its various products. However, OMEGA neither assumes responsibility for any omissions or errors nor assumes liability for any damages that result from the use of its products in accordance with information provided by OMEGA, either verbal or written. OMEGA warrants only that the parts manufactured by the company will be as specified and free of defects. OMEGA MAKES NO OTHER WARRANTIES OR REPRESENTATIONS OF ANY KIND WHATSOEVER, EXPRESSED OR IMPLIED, EXCEPT THAT OF TITLE, AND ALL IMPLIED WARRANTIES INCLUDING ANY WARRANTY OF MERCHANTABILITY AND FITNESS FOR A PARTICULAR PURPOSE ARE HEREBY DISCLAIMED. LIMITATION OF LIABILITY: The remedies of purchaser set forth herein are exclusive, and the total liability of OMEGA with respect to this order, whether based on contract, warranty, negligence, indemnification, strict liability or otherwise, shall not exceed the purchase price of the component upon which liability is based. In no event shall OMEGA be liable for consequential, incidental or special damages.

CONDITIONS: Equipment sold by OMEGA is not intended to be used, nor shall it be used: (1) as a "Basic Component" under 10 CFR 21 (NRC), used in or with any nuclear installation or activity; or (2) in medical applications or used on humans. Should any Product(s) be used in or with any nuclear installation or activity, medical application, used on humans, or misused in any way, OMEGA assumes no responsibility as set forth in our basic WARRANTY/DISCLAIMER language, and, additionally, purchaser will indemnify OMEGA and hold OMEGA harmless from any liability or damage whatsoever arising out of the use of the Product(s) in such a manner.

RETURN REQUESTS/INQUIRIES

Direct all warranty and repair requests/inquiries to the OMEGA Customer Service Department. BEFORE RETURNING ANY PRODUCT(S) TO OMEGA, PURCHASER MUST OBTAIN AN AUTHORIZED RETURN (AR) NUMBER FROM OMEGA'S CUSTOMER SERVICE DEPARTMENT (IN ORDER TO AVOID PROCESSING DELAYS). The assigned AR number should then be marked on the outside of the return package and on any correspondence.

The purchaser is responsible for shipping charges, freight, insurance and proper packaging to prevent breakage in transit.

FOR **WARRANTY** RETURNS, please have the following information available BEFORE contacting OMEGA:

1. Purchase Order number under which the product was PURCHASED,
2. Model and serial number of the product under warranty, and
3. Repair instructions and/or specific problems relative to the product.

FOR **NON-WARRANTY** REPAIRS, consult OMEGA for current repair charges. Have the following information available BEFORE contacting OMEGA:

1. Purchase Order number to cover the COST of the repair,
2. Model and serial number of the product, and
3. Repair instructions and/or specific problems relative to the product.

OMEGA's policy is to make running changes, not model changes, whenever an improvement is possible. This affords our customers the latest in technology and engineering.

OMEGA is a registered trademark of OMEGA ENGINEERING, INC.

© Copyright 2009 OMEGA ENGINEERING, INC. All rights reserved. This document may not be copied, photocopied, reproduced, translated, or reduced to any electronic medium or machine-readable form, in whole or in part, without the prior written consent of OMEGA ENGINEERING, INC.

Where Do I Find Everything I Need for Process Measurement and Control? **OMEGA...Of Course!** *Shop online at omega.comSM*

TEMPERATURE

- ☑ Thermocouple, RTD & Thermistor Probes, Connectors, Panels & Assemblies
- ☑ Wire: Thermocouple, RTD & Thermistor
- ☑ Calibrators & Ice Point References
- ☑ Recorders, Controllers & Process Monitors
- ☑ Infrared Pyrometers

PRESSURE, STRAIN AND FORCE

- ☑ Transducers & Strain Gages
- ☑ Load Cells & Pressure Gages
- ☑ Displacement Transducers
- ☑ Instrumentation & Accessories

FLOW/LEVEL

- ☑ Rotameters, Gas Mass Flowmeters & Flow Computers
- ☑ Air Velocity Indicators
- ☑ Turbine/Paddlewheel Systems
- ☑ Totalizers & Batch Controllers

pH/CONDUCTIVITY

- ☑ pH Electrodes, Testers & Accessories
- ☑ Benchtop/Laboratory Meters
- ☑ Controllers, Calibrators, Simulators & Pumps
- ☑ Industrial pH & Conductivity Equipment

DATA ACQUISITION

- ☑ Data Acquisition & Engineering Software
- ☑ Communications-Based Acquisition Systems
- ☑ Plug-in Cards for Apple, IBM & Compatibles
- ☑ Datalogging Systems
- ☑ Recorders, Printers & Plotters

HEATERS

- ☑ Heating Cable
- ☑ Cartridge & Strip Heaters
- ☑ Immersion & Band Heaters
- ☑ Flexible Heaters
- ☑ Laboratory Heaters

ENVIRONMENTAL MONITORING AND CONTROL

- ☑ Metering & Control Instrumentation
- ☑ Refractometers
- ☑ Pumps & Tubing
- ☑ Air, Soil & Water Monitors
- ☑ Industrial Water & Wastewater Treatment
- ☑ pH, Conductivity & Dissolved Oxygen Instruments