

CE



User's Guide

Shop online at

omega.com[®]

Ω OMEGA[®]

www.omega.com

e-mail: info@omega.com



FMA 1400 and FMA 1500 Mass Flow Meters and Controllers



OMEGAnet® Online Service www.omega.com	Internet e-mail info@omega.com
---	--

Servicing North America:

USA: ISO 9001 Certified One Omega Drive, Box 4047
Stamford CT 06907-0047
Tel: (203) 359-1660 FAX: (203) 359-7700
e-mail: info@omega.com

Canada: 976 Bergar
Laval (Quebec) H7L 5A1
Tel: (514) 856-6928 FAX: (514) 856-6886
e-mail: info@omega.ca

For immediate technical or application assistance:

USA and Canada: Sales Service: 1-800-826-6342 / 1-800-TC-OMEGA®
Customer Service: 1-800-622-2378 / 1-800-622-BEST®
Engineering Service: 1-800-872-9436 / 1-800-USA-WHEN®
TELEX: 996404 EASYLINK: 62968934 CABLE: OMEGA

Mexico: En Español: (001) 203-359-7803 e-mail: espanol@omega.com
FAX: (001) 203-359-7807 info@omega.com.mx

Servicing Europe:

Benelux: Postbus 8034, 1180 LA Amstelveen, The Netherlands
Tel: +31 (0)20 3472121 FAX: +31 (0)20 6434643
Toll Free in Benelux: 0800 0993344
e-mail: sales@omegaeng.nl

Czech Republic: Rudé arm-dy 1868, 733 01 Karvin- 8
Tel: +420 (0)59 6311899 FAX: +420 (0)59 6311114
Toll Free: 0800-1-66342 e-mail: info@omegashop.cz

France: 11, rue Jacques Cartier, 78280 Guyancourt, France
Tel: +33 (0)1 61 37 29 00 FAX: +33 (0)1 30 57 54 27
Toll Free in France: 0800 466 342
e-mail: sales@omega.fr

Germany/Austria: Daimlerstrasse 26, D-75392 Deckenpfronn, Germany
Tel: +49 (0)7056 9398-0 FAX: +49 (0)7056 9398-29
Toll Free in Germany: 0800 639 7678
e-mail: info@omega.de

United Kingdom: ISO 9002 Certified One Omega Drive, River Bend Technology Centre
Northbank, Irlam, Manchester
M44 5BD United Kingdom
Tel: +44 (0)161 777 6611
Toll Free in United Kingdom: 0800-488-48 FAX: +44 (0)161 777 6622
e-mail: sales@omega.co.uk

It is the policy of OMEGA to comply with all worldwide safety and EMC/EMI regulations that apply. OMEGA is constantly pursuing certification of its products to the European New Approach Directives. OMEGA will add the CE mark to every appropriate device upon certification.

The information contained in this document is believed to be correct, but OMEGA Engineering, Inc. accepts no liability for any errors it contains, and reserves the right to alter specifications without notice.

WARNING: These products are not designed for use in, and should not be used for, patient-connected applications.

TABLE OF CONTENTS

1. UNPACKING THE FMA 1400/1500 MASS FLOW METER.....	1
1.1 Inspect Package for External Damage.....	1
1.2 Unpack the Mass Flow Meter/Controller.....	1
1.3 Returning Merchandise for Repair.....	1
2. INSTALLATION.....	1
2.1 Primary Gas Connections.....	1
2.2 Electrical Connections.....	2
3. PRINCIPLE OF OPERATION.....	4
4. SPECIFICATIONS.....	5
4.1 FMA 1500 Mass Flow Meters for ranges up to and above 10 L/min.....	5
4.2 FMA 1400 Mass Flow Controllers for ranges up to and above 10 L/min.....	6
4.3 CE Compliance.....	7
5. OPERATING INSTRUCTIONS.....	9
5.1 Preparation and Warm Up.....	9
5.2 Flow Signal Output Readings.....	10
5.3 Swamping Condition.....	10
5.4 Set Point Reference Signal (FMA 1400).....	10
5.5 TTL, Valve OFF Control (FMA 1400).....	11
5.6 Valve Test/Purge (FMA 1400).....	11
6. MAINTENANCE.....	12
6.1 Introduction.....	12
6.2 Flow Path Cleaning.....	12
6.2.1 Restrictor Flow Element (RFE).....	12
6.2.2 FMA 1400/1500 Ranges up to 10 L/min.....	13
6.2.3 FMA 1400/1500 Ranges above 10 L/min.....	13
6.2.4 Valve Maintenance (FMA 1400).....	13
7. CALIBRATION PROCEDURES.....	14
7.1 Flow Calibration.....	14
7.2 Calibration of FMA 1500 Mass Flow Meters.....	15
7.2.1 Connections and Initial Warm Up.....	15
7.2.2 ZERO Adjustment.....	16
7.2.3 SPAN Adjustment.....	16

7.3 Linearity Adjustment.....	16
7.3.1 Connections and Initial Warm Up.....	16
7.3.2 ZERO Adjustment.....	17
7.3.3 25% Flow Adjustment.....	17
7.3.4 50% Flow Adjustment.....	17
7.3.5 75% Flow Adjustment.....	17
7.3.6 100% Flow Adjustment.....	17
7.4 Calibration of FMA 1400 Mass Flow Controllers.....	17
7.4.1 Disable Solenoid Valve.....	17
7.4.2 Valve Adjustment.....	18
7.4.3 Full Scale Flow Adjustment.....	18
7.4.4 25% Flow Adjustment.....	18
7.4.5 50% Flow Adjustment.....	18
7.4.6 75% Flow Adjustment.....	18
7.4.7 100% Flow Adjustment.....	18
8. TROUBLESHOOTING.....	19
8.1 Common Conditions.....	19
8.2 Troubleshooting Guide.....	20
8.3 Technical Assistance.....	22
9. CALIBRATION CONVERSIONS FROM REFERENCE GASES.....	22
APPENDIX 1 COMPONENT DIAGRAMS.....	23
APPENDIX 2 GAS FACTOR TABLE ("K" FACTORS).....	24
APPENDIX 3 DIMENSIONAL DRAWINGS.....	28
APPENDIX 4 WARRANTY.....	32

TRADEMARKS

Buna® is a registered trademark of DuPont Dow Elastomers.

Kalrez® is a registered trademark of DuPont Dow Elastomers.

Neoprene® is a registered trademark of DuPont.

Omega®-is a registered trademark of Omega Engineering, Inc.

VCR® is a registered trademark of Crawford Fitting Co.

Viton® is a registered trademark of Dupont Dow Elastomers L.L.C.

1. UNPACKING THE FMA 1400/1500 MASS FLOW METER AND CONTROLLER

1.1 Inspect Package for External Damage

Remove the Packing List and verify that you have received all equipment. If you have any questions about the shipment, please call the Omega® Customer Service Department at 1-800-622-2378 or (203) 359-1660.

Your FMA 1400/1500 Mass Flow Meter/Controller was carefully packed in a sturdy cardboard carton, with anti-static cushioning materials to withstand shipping shock. Upon receipt, inspect the package for possible external damage. In case of external damage to the package contact the shipping company immediately.

1.2 Unpack the Mass Flow Meter/Controller

Open the carton carefully from the top and inspect for any sign of concealed shipping damage. In addition to contacting the shipping carrier please forward a copy of any damage report to Omega® directly.

When unpacking the instrument please make sure that you have all the items indicated on the Packing List. Please report any shortages promptly.

1.3 Returning Merchandise for Repair

Please contact an Omega customer service representative and request a **Return Authorization Number (AR)**.

It is mandatory that any equipment returned for servicing be purged and neutralized of any dangerous contents including but not limited to toxic, bacterially infectious, corrosive or radioactive substances. No work shall be performed on a returned product unless the customer submits a fully executed, signed SAFETY CERTIFICATE. Please request form from the Service Manager.

2. INSTALLATION

2.1 Primary Gas Connections

Please note that the FMA 1400/1500 Mass Flow Meter/Controller will not operate with liquids. Only clean gases are allowed to be introduced into the instrument. If gases are contaminated they must be filtered to prevent the introduction of impediments into the sensor.



Caution: FMA 1400/1500 transducers should not be used for monitoring OXYGEN gas unless specifically cleaned and prepared for such application. For more information, contact Omega®.

Attitude sensitivity of the Mass Flow Meter is $\pm 15^\circ$. This means that the gas flow path of the Flow Meter/Controller must be horizontal within those stated limits. Should there be need for a different orientation of the meter, re calibration may be necessary.

It is also preferable to install the FMA 1400/1500 transducer in a stable environment, free of frequent and sudden temperature changes, high moisture, and drafts.

Prior to connecting gas lines inspect all parts of the piping system including ferules and fittings for dust or other contaminants.

Be sure to observe the direction of gas flow as indicated by the arrow on the front of the meter when connecting the gas system to be monitored.

Insert tubing into the compression fittings until the ends of the properly sized tubings home flush against the shoulders of the fittings. Compression fittings are to be tightened according to the manufacturer's instructions to one and one quarter turns. Avoid over tightening which will seriously damage the Restrictor Flow Elements (RFE's)!

FMA 1400/1500 transducers are supplied with standard 1/4 inch (FMA 1400/1500 for ranges up to and above 10 L/min) or 3/8 inch (FMA 1400/1500 for ranges above 10 L/min), or optional 1/8 inch inlet and outlet compression fittings which should not be removed unless the meter is being cleaned or calibrated for a new flow range.

Using a Helium Leak Detector or other equivalent method perform a thorough leak test of the entire system. (All FMA 1400/1500's are checked prior to shipment for leakage within stated limits. See specifications in this manual.)

2.2 Electrical Connections

FMA 1400/1500 transducers require a +15VDC and -15VDC power supply to operate. Additionally, a readout panel meter, digital multimeter, or other equivalent device is required to observe the flow signal. A variable analog 0-5VDC reference input is required for FMA 1400 models. The Omega® FMA14PD Series accessory Command Modules offer a convenient and compact means to fulfill these needs.

FMA 1400/1500 transducers come with a 15 pin "D" connector. The pin diagram is provided on figure 2-3.

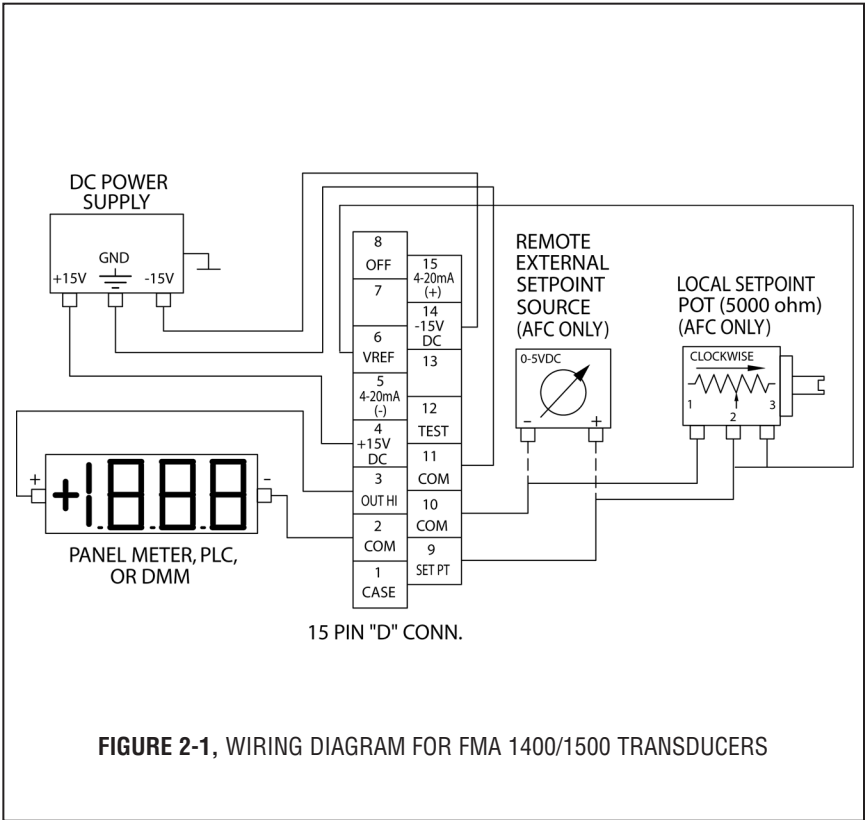

FIGURE 2-1, WIRING DIAGRAM FOR FMA 1400/1500 TRANSDUCERS

PIN FUNCTION

- 1** Chassis Ground
- 2** Common, Signal Ground For Pin 3
- 3** 0-5 VDC Flow Signal
- 4** +15 VDC Power Supply
- 5** (-) 4-20 mA Flow Signal (optional)
- 6** +7 VDC for Local Set Point
- 7** (unassigned)
- 8** TTL Valve Off Control (FMA 1400)
- 9** Control Set Point Input 0.5 VDC (FMA 1400)
- 10** Common, Signal Ground for Pin 9
- 11** Common, Power Supply
- 12** Valve Test Point/Purge (FMA 1400)
- 13** (unassigned)
- 14** -15 VDC Power Supply
- 15** (+) 4-20 mA Flow Signal (optional)

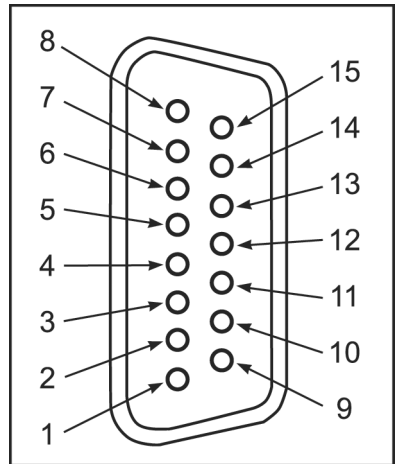

FIGURE 2-3, FMA 1400/1500 15 PIN "D" CONNECTOR CONFIGURATION

Important notes:

In general, "D" Connector numbering patterns are standardized. There are, however, some connectors with nonconforming patterns and the numbering sequence on your mating connector may or may not coincide with the numbering sequence shown in our pin configuration table above. It is imperative that you match the appropriate wires in accordance with the correct sequence regardless of the particular numbers displayed on your mating connector.

Make sure power is OFF when connecting or disconnecting any cables in the system.

The (+) and (-) power inputs are each protected by a 750mA M (medium time-lag) resettable fuse. If a shorting condition or polarity reversal occurs, the fuse will cut power to the flow transducer circuit. Disconnect the power to the unit, remove the faulty condition, and reconnect the power. The fuse will reset once the faulty condition has been removed.

Cable length may not exceed 9.5 feet (3 meters).

Use of the FMA 1400/1500 flow transducer in a manner other than that specified in this manual or in writing from Omega®, may impair the protection provided by the equipment.

3. PRINCIPLE OF OPERATION

The stream of gas entering the Mass Flow transducer is split by shunting a small portion of the flow through a capillary stainless steel sensor tube. The remainder of the gas flows through the primary flow conduit. The geometry of the primary conduit and the sensor tube are designed to ensure laminar flow in each branch. According to principles of fluid dynamics the flow rates of a gas in the two laminar flow conduits are proportional to one another. Therefore, the flow rates measured in the sensor tube are directly proportional to the total flow through the transducer.

In order to sense the flow in the sensor tube, heat flux is introduced at two sections of the sensor tube by means of precision wound heater-sensor coils. Heat is transferred through the thin wall of the sensor tube to the gas flowing inside. As gas flow takes place heat is carried by the gas stream from the upstream coil to the downstream coil windings. The resultant temperature dependent resistance differential is detected by the electronic control circuit. The measured gradient at the sensor windings is linearly proportional to the instantaneous rate of flow taking place.

An output signal is generated that is a function of the amount of heat carried by the gases to indicate mass-molecular based flow rates.

Additionally, FMA 1400 model Mass Flow Controllers incorporate a proportionating solenoid valve. The closed loop control circuit of the FMA 1400 continuously compares the mass flow output with the selected flow rate. Deviations from the set point are corrected by compensating valve adjustments, thus maintaining the desired flow parameters.

4. SPECIFICATIONS

FLOW MEDIUM: Please note that FMA 1400/1500 Mass Flow Meters and Controllers for ranges up to and above 10 L/min are designed to work with clean gases only. Never try to meter or control flow rates of liquids with any FMA 1500's or FMA 1400's.

CALIBRATIONS: Performed at standard conditions [14.7 psia (1.01 bars) and 70°F (21.1°C)] unless otherwise requested or stated.

ENVIRONMENTAL (per IEC 664): Installation Level II; Pollution Degree II

4.1 FMA 1500 Mass Flow Meters for ranges up to and above 10 L/min

ACCURACY: $\pm 1\%$ of full scale, including linearity for gas temperatures ranging from 59°F to 77°F (15°C to 25°C) and pressures of 10 to 60 psia (0.7 to 4.1 bars).

REPEATABILITY: $\pm 0.2\%$ of full scale.

TEMPERATURE COEFFICIENT: 0.1% of full scale/ °C.

PRESSURE COEFFICIENT: 0.01% of full scale/psi (0.07 bar).

RESPONSE TIME: 300ms time constant; approximately 1 second to within $\pm 2\%$ of set flow rate for 25% to 100% of full scale flow rate.

GAS PRESSURE: 500 psig (34.5 bars) maximum; optimum pressure is 20 psig (1.4 bars).

GAS AND AMBIENT TEMPERATURE: 41°F to 122°F (5°C to 50°C).

RELATIVE GAS HUMIDITY: Up to 70%.

LEAK INTEGRITY: 1×10^{-9} sccs He maximum to the outside environment.

ATTITUDE SENSITIVITY: 1% shift for a 90 degree rotation from horizontal to vertical; standard calibration is in horizontal position.

OUTPUT SIGNALS: Linear 0-5 VDC (2000 Ω minimum load impedance); 4-20 mA optional (50-500 Ω maximum loop resistance); 20 mV peak to peak max noise.

TRANSDUCER INPUT POWER: +15 $\pm 5\%$ VDC, 80 mA max, 1.2 watts; -15 $\pm 5\%$ VDC, 10 mA max, 0.15 watts.

Power inputs are each protected by a 750mA M (medium time-lag) resettable fuse, and a rectifier diode for polarity protection.

WETTED MATERIALS: 316 stainless steel, VITON® O-rings; BUNA-N®, NEOPRENE® or KALREZ® O-rings are optional.

Omega® makes no expressed or implied guarantees of corrosion resistance of mass flow meters as pertains to different flow media reacting with components of meters. It is the customers' sole responsibility to select the model suitable for a particular gas based on the fluid contacting (wetted) materials offered in the different models.

INLET AND OUTLET CONNECTIONS: 1/4" compression fittings standard on ranges up to 50 L/min; 3/8" compression fittings standard on 60, 80, and 100 L/min ranges.

Optional: 1/8" compression fittings and 1/4" VCR fittings on ranges up to 10 L/min.
3/8" compression fittings and 1/4" VCR fittings on ranges above 10 L/min up to 50 L/min.

TRANSDUCER INTERFACE CABLE: Flat cable with male 15-pin "D" connector is standard. Optional shielded cable is available with male/female 15-pin "D" connector ends. [Cable length may not exceed 9.5 feet (3 meters)].

4.2 FMA 1400 Mass Flow Controllers for ranges up to and above 10 L/min

ACCURACY: $\pm 1\%$ of full scale, including linearity for gas temperatures ranging from 59°F to 77°F (15°C to 25°C) and pressures of 10 to 60 psia (0.7 to 4.1 bars).

REPEATABILITY: $\pm 0.2\%$ of full scale.

TEMPERATURE COEFFICIENT: 0.1% of full scale/°C.

PRESSURE COEFFICIENT: 0.01% of full scale/psi (0.07 bar).

RESPONSE TIME: FMA 1400 for ranges up to 10 L/min:
300ms time constant; approximately 1 second to within $\pm 2\%$ of set flow rate for 25% to 100% of full scale flow.

FMA 1400 for ranges above 10 L/min:
600ms time constant; approximately 2 seconds to within $\pm 2\%$ of set flow rate for 25% to 100% of full scale flow.

GAS PRESSURE: 500 psig (34.5 bars) maximum; optimum pressure is 20 psig (1.4 bars); 25 psig (1.7 bars gauge) for FMA 1400 ranges above 10 L/min.

MAXIMUM DIFFERENTIAL PRESSURES: 40 psig (2.61 bars) for FMA 1400 ranges above 10 L/min. 50 psig (3.34 bars) for FMA 1400 ranges up to and above 10 L/min. Optimum differential pressure is 25 psid (1.7 bars). See Table IV for pressure drops associated with various models and flow rates.

GAS AND AMBIENT TEMPERATURE: 41°F to 122°F (5°C to 50°C).

RELATIVE GAS HUMIDITY: up to 70%.

LEAK INTEGRITY: 1×10^{-9} sccs He maximum to the outside environment.

ATTITUDE SENSITIVITY: 1% shift for a 90 degree rotation from horizontal to vertical; standard calibration is in horizontal position.

OUTPUT SIGNALS: Linear 0-5 VDC (2000 Ω minimum load impedance); 4-20 mA optional (50-500 Ω loop resistance); 20 mV peak to peak max noise.

COMMAND SIGNAL: 0-5 VDC (200K Ω input impedance).

TRANSDUCER INPUT POWER: **FMA 1400 ranges up to 10 L/min:**
(15 sLit/min max) +15 \pm 5% VDC, 80 mA max, 1.2 watts max; -15 \pm 5% VDC, 200 mA max; 3 watts max;

FMA 1400 ranges above 10 L/min:
(100 sLit/min max) +15 \pm 5% VDC, 80 mA max, 1.2 watts max; -15 \pm 5% VDC, 600 mA max, 9 watts max.

Power inputs are each protected by a 750mA M (medium time-lag) resettable fuse, and a rectifier diode for polarity protection.

WETTED MATERIALS: 316 stainless steel, 416 stainless steel, VITON® O-rings; BUNA-N®, NEOPRENE® or KALREZ® O-rings are optional.

Omega® makes no expressed or implied guarantees of corrosion resistance of mass flow meters as pertains to different flow media reacting with components of meters. It is the customers' sole responsibility to select the model suitable for a particular gas based on the fluid contacting (wetted) materials offered in the different models.

INLET AND OUTLET CONNECTIONS: 1/4" (FMA 1400 ranges up to and above 10 L/min) or 3/8" (FMA 1400 for ranges above 10 L/min) compression fittings standard; 1/8" or 3/8" compression fittings and 1/4" VCR® fittings are optional.

TRANSDUCER INTERFACE CABLE: Flat cable with female 15-pin "D" connector ends is standard. Optional shielded cable is available with male/female 15-pin "D" connector ends. [Cable length may not exceed 9.5 feet (3 meters)]

4.3 CE Compliance

Any model FMA 1500 or FMA 1400 bearing a CE marking on it, is in compliance with the below stated test standards currently accepted.

EMC Compliance with 89/336/EEC as amended;
Emission Standard: EN 55011:1991, Group 1, Class A
Immunity Standard: EN 55082 1:1992

FLOW RANGES

TABLE I FMA 1500/1400 FOR RANGES UP TO 10 L/MIN
LOW FLOW MASS FLOW METER/CONTROLLERS*

CODE	scc/min [N ₂]	CODE	std liters/min [N ₂]
02	0 to 10	14	0 to 1
04	0 to 20	16	0 to 2
06	0 to 50	18	0 to 5
08	0 to 100	20	0 to 10
10	0 to 200		
12	0 to 500		

TABLE II FMA 1500/1400 FOR RANGES ABOVE 10 L/MIN
MEDIUM FLOW MASS FLOW METER/CONTROLLERS*

CODE	standard liters/min [N ₂]
23	15
24	20
26	30
27	40
28	50

TABLE III FMA 1500/1400 FOR RANGES ABOVE 10 L/MIN
HIGH FLOW MASS FLOW METER/CONTROLLERS*

CODE	standard liters/min [N ₂]
40	60
41	80
42	100

*Flow rates are stated for Nitrogen at STP conditions [i.e. 70°F (21.1°C) at 1 atm].
For other gases use the K factor as a multiplier from APPENDIX 2.

TABLE IV PRESSURE DROPS

MODEL	FLOW RATE [std liters/min]	MAXIMUM PRESSURE DROP		
		[mm H ₂ O]	[psid]	[mbar]
FMA 1500	up to 10	25	0.04	2.5
	15	63	0.09	6.4
	20	300	0.44	30
	30	800	1.18	81
	40	1480	2.18	150
	50	2200	3.23	223
	60	3100	4.56	314
	80	4422	6.50	448
	100	5500	8.08	557
FMA 1400	up to 10	720	1.06	75
	15	2630	3.87	266
	20	1360	2.00	138
	30	2380	3.50	241
	40	3740	5.50	379
	50	5440	8.00	551
	60	7480	11.00	758
	80	10204	15.00	1034
	100	12850	18.89	1302

TABLE V APPROXIMATE WEIGHTS

MODEL	WEIGHT	SHIPPING WEIGHT
FMA 1500 ranges up to 10 L/min transmitter	1.71 lbs (0.78 kg)	3.21 lbs (1.46 kg)
FMA 1500 ranges above 10 L/min transmitter	2.42 lbs (1.10 kg)	3.92 lbs (1.78 kg)
FMA 1400 ranges up to 10 L/min transmitter	2.20 lbs (1.00 kg)	3.70 lbs (1.68 kg)
FMA 1400 ranges above 10 L/min transmitter	2.84 lbs (1.29 kg)	4.34 lbs (1.97 kg)

5. OPERATING INSTRUCTIONS

5.1 Preparation and Warm Up

It is assumed that the Mass Flow Meter or Controller has been correctly installed and thoroughly leak tested as described in section 2. Make sure the flow source is OFF. Power up the transducer using your own power supply (or turn the POWER switch to the ON position at the front panel of your FMA14PD Series Command Module). Allow the Mass Flow Meter or Controller to warm-up for a minimum of 15 minutes.

During initial powering of the FMA 1400/1500 transducer, the flow output signal will be indicating a higher than usual output. This is indication that the FMA 1400/1500 transducer has not yet attained it's minimum operating temperature. This condition will automatically cancel within a few minutes and the transducer should eventually zero.



Caution: If the valve is left in the AUTO (control) or OPEN mode for an extended period of time, it may become warm or even hot to the touch. Use care in avoiding direct contact with the valve during operation.

5.2 Flow Signal Output Readings

The flow signal output can be viewed on the panel meter, digital multimeter, or other display device used as shown in figure 2-1.

When using the accessory FMA14PD Series Command Module the flow rate will appear on the display at the front panel. The observed reading is a 0 to 100% indication (direct engineering units are optional). [If using a multichannel readout, be sure that the CHANNEL selector switch is set to the correct channel.]

Analog output flow signals of 0 to 5 VDC or optional 4 to 20 mA are attained at the appropriate pins of the 15-pin "D" connector (see Figure 2-3) on the top of the FMA 1400/1500 transducer. The output flow signal is also available at the DATA connector on the rear panel of the FMA14PD Series Command Module.

The default calibration is performed for 0 to 5 VDC output signal. If 4-20 mA output signal is used for flow indication on the FMA 1400, the accuracy of the actual flow rate will be in the specified range ($\pm 1.0\%$) of full scale, but the total uncertainty of the output reading may be in the range of $\pm 2.0\%$ of full scale. Optional calibration for 4-20 mA output signal is available upon request at time of order.

Meter signal output is linearly proportional to the mass molecular flow rate of the gas being metered. The full scale range and gas for which your meter has been calibrated are shown on the flow transducer's front label.

5.3 Swamping Condition

If a flow of more than 10% above the maximum flow rate of the Mass Flow Meter is taking place, a condition known as "swamping" may occur. Readings of a "swamped" meter cannot be assumed to be either accurate or linear. Flow must be restored to below 110% of maximum meter range. Once flow rates are lowered to within calibrated range, the swamping condition will end. Operation of the meter above 110% of maximum calibrated flow may increase recovery time.

5.4 Set Point Reference Signal (FMA 1400)

FMA 1400 flow controllers have a built-in solenoid valve and allow the user to set the flow to any desired flow rate within the range of the particular model installed. This valve is normally closed when no power is applied.

The set point input responds to an analog 0 to 5 VDC reference voltage. This volt-

age is a linear representation of 0 to 100% of the full scale mass flow rate. Response time to set point changes are 1 second (FMA 1400 for ranges up to 10 L/min) and 2 seconds (FMA 1400 for ranges above 10 L/min) to within 2% of the final flow over 25 to 100% of full scale.

On pin 6 of the FMA 1400 transducer is a regulated and constant +5VDC output signal. This signal may be used in conjunction with a local set point potentiometer for flow setting.

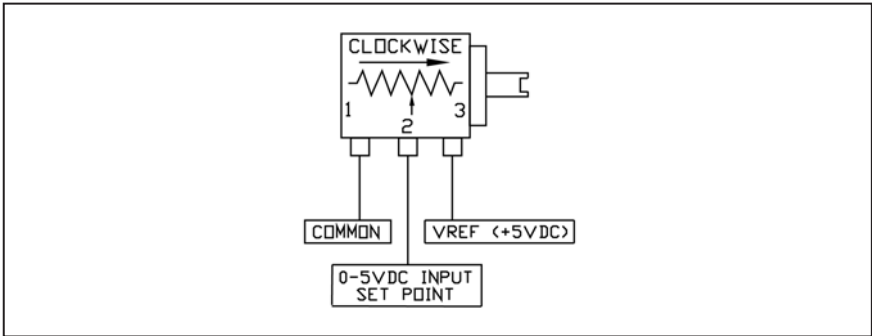

FIGURE 5-1, LOCAL SET POINT POTENTIOMETER CONNECTIONS

It is recommended that a potentiometer between 5K to 100K ohm and capable of at least 10-turns or more for adjustment be used. Use the control potentiometer to command the percentage of flow desired.

Alternatively, a variable 0 to 5VDC analog signal may be applied directly to the SET POINT and COMMON connections of the FMA 1400 transducer (see Figure 2-1).

5.5 TTL, Valve OFF Control (FMA 1400)

It may, at times, be desirable to set the flow and maintain that setting while being able to turn the flow control valve off and on again. This can be accomplished by applying a (TTL compatible) high and low signal of +5 VDC and 0 VDC to pin 8, on the 15-pin "D" connector. When 0 VDC (LOW) signal is applied, the solenoid valve is not powered and therefore will remain normally closed. Conversely, a +5 VDC (HIGH) signal applied will allow the solenoid valve to remain active. The solenoid valve will remain active when the VALVE OFF pin remains "floating".

The simplest means for utilizing the VALVE OFF control feature, is to connect a toggle switch between the COMMON and VALVE OFF pins of the FMA 1400 transducer. Toggling the switch on and off will allow for activating and deactivating the solenoid valve.

5.6 Valve Test/Purge (FMA 1400)

At times, it may be necessary to purge the flow system with a neutralizing gas such as pure dry nitrogen. The FMA 1400 transducer is capable of a full open condition for the solenoid valve, regardless of set point conditions. For FMA 1400's

utilizing +15VDC valve configuration, connecting the TEST pin 12 on 15-pin "D" connectors) to ground will fully open the valve. For FMA 1400's with a +30VDC valve configuration, connecting the TEST pin to +15VDC will fully open the valve.

6. MAINTENANCE

6.1 Introduction

It is important that the Mass Flow Meter/Controller is used with clean, filtered gases only. Liquids may not be metered. Since the RTD sensor consists, in part, of a small capillary stainless steel tube, it is prone to occlusion due to impediments or gas crystallization. Other flow passages are also easily obstructed. Therefore, great care must be exercised to avoid the introduction of any potential flow impediment. To protect the instrument a 50 micron (FMA 1500/1400 for ranges up to 10 L/min) or 60 micron (FMA 1500/1400 for ranges above 10 L/min) filter is built into the inlet of the flow transducer. The filter screen and the flow paths may require occasional cleaning as described below. There is no other recommended maintenance required. It is good practice, however, to keep the meter away from vibration, hot or corrosive environments and excessive RF or magnetic interference.

If periodic calibrations are required they should be performed by qualified personnel and calibrating instruments, as described in section 7. It is recommended that units are returned to Omega® for repair service and calibration.



CAUTION: TO PROTECT SERVICING PERSONNEL IT IS MANDATORY THAT ANY INSTRUMENT BEING SERVICED IS COMPLETELY PURGED AND NEUTRALIZED OF TOXIC, BACTERIOLOGICALLY INFECTED, CORROSIVE OR RADIOACTIVE CONTENTS.

6.2 Flow Path Cleaning

Before attempting any disassembly of the unit for cleaning, try inspecting the flow paths by looking into the inlet and outlet ends of the meter for any debris that may be clogging the flow through the meter. Remove debris as necessary. If the flow path is not unclogged, then proceed with steps below.

Do not attempt to disassemble the sensor. If blockage of the sensor tube is not alleviated by flushing through with cleaning fluids, please return meter to Omega® for servicing.

6.2.1 Restrictor Flow Element (RFE)

The Restrictor Flow Element (RFE) is a precision flow divider inside the transducer, which splits the inlet gas flow by a preset amount to the sensor and main flow paths. The particular RFE used in a given Mass Flow Meter/Controller depends on the gas and flow range of the instrument.

6.2.2 FMA 1400/1500 for ranges up to 10 L/min

Unscrew the inlet compression fitting of meter. Note that the Restrictor Flow Element (RFE) is connected to the inlet fitting.

Carefully disassemble the RFE from the inlet connection. The 50 micron filter screen will now become visible. Push the screen out through the inlet fitting. Clean or replace each of the removed parts as necessary. If alcohol is used for cleaning, allow time for drying.

Inspect the flow path inside the transducer for any visible signs of contaminant's. If necessary, flush the flow path through with alcohol. Thoroughly dry the flow paths by flowing clean dry gas through.

Carefully re-install the RFE and inlet fitting, avoiding any twisting and deforming the RFE. Be sure that no dust has collected on the O-ring seal.



Note: Over tightening will deform and render the RFE defective.

It is advisable that at least one calibration point be checked after re-installing the inlet fitting - see section 7.

6.2.3 FMA 1400/1500 for ranges above 10 L/min

Unscrew the four socket head cap screws (two 10-24 and two 6-32) at the inlet side of the meter. This will release the short square block containing the inlet compression fitting.

The 60 micron filter screen will now become visible. Remove the screen. DO NOT remove the RFE inside the flow transducer! Clean or replace each of the removed parts as necessary. If alcohol is used for cleaning, allow time for drying.

Inspect the flow path inside the transducer for any visible signs of contaminant's. If necessary, flush the flow path through with alcohol. Thoroughly dry the flow paths by flowing clean dry gas through.

Re-install the inlet parts and filter screen. Be sure that no dust has collected on the O-ring seal.

It is advisable that at least one calibration point be checked after re-installing the inlet fitting - see section 7.

6.2.4 Valve Maintenance (FMA 1400)

The solenoid valve consists of 316 and 416 stainless steel, and VITON® (or optional NEOPRENE® or KALREZ®) O-rings and seals. No regular maintenance is required except for periodic cleaning. Various corrosive gases may demand more frequent replacement of VITON® O-rings and seals inside the valve. Be sure to use an elastomer material, appropriate for your specific gas application.

Contact Omega® for optional sealing materials available.

Set the FMA 1400 into PURGE mode, and attempt to flush through with a clean, filtered, and neutral gas such as nitrogen. [Another option for fully opening the valve is to remove the plastic cap on top of the valve, and turn the set screw counterclockwise until it stops. See section 7.4 for valve adjustment, to return the valve to functional use.]

7. CALIBRATION PROCEDURES



Note: Removal of the factory installed calibration seals and/or any adjustments made to the meter, as described in this section, will void any calibration warranty applicable.

7.1 Flow Calibration

Omega® Engineering Flow Calibration Laboratory offers professional calibration support for Mass Flow Meters and Controllers, using precision calibrators under strictly controlled conditions. NIST traceable calibrations are available. Calibrations can also be performed at customers' site using available standards.

Factory calibrations are performed using NIST traceable precision volumetric calibrators incorporating liquid sealed frictionless actuators.

Generally, calibrations are performed using dry nitrogen gas. The calibration can then be corrected to the appropriate gas desired based on relative correction [K] factors shown in the gas factor table see Appendix 2. A reference gas, other than nitrogen, may be used to closer approximate the flow characteristics of certain gases. This practice is recommended when a reference gas is found with thermodynamic properties similar to the actual gas under consideration. The appropriate relative correction factor should be recalculated - see section 9.

It is standard practice to calibrate Mass Flow Meters/Controllers with dry nitrogen gas at 70°F (21.1°C), 20 psig (1.4 bars) [25 psig (1.7 bars) for FMA 1400 ranges above 10 L/min] inlet pressure and 0 psig (0 bar) outlet pressure. It is best to calibrate the FMA 1400/1500 transducers to actual operating conditions. Specific gas calibrations of non-toxic and non-corrosive gases are available at specific conditions. Please contact Omega® for a price quotation.

It is recommended that a flow calibrator of at least four times better collective accuracy than that of the Mass Flow Meter/Controller to be calibrated be used. Equipment required for calibration includes a flow calibration standard and a certified high sensitivity multimeter (which together have a collective accuracy of $\pm 0.25\%$ or better), an insulated (plastic) screwdriver, a flow regulator (example: metering needle valve) installed upstream from the Mass Flow Meter and a pressure regulated source of dry filtered nitrogen gas (or other suitable reference gas). The gas and ambient temperature, as well as inlet and outlet pressure conditions should be set up in accordance with actual operating conditions.

Calibration potentiometer locations are illustrated in Figure 7-1.

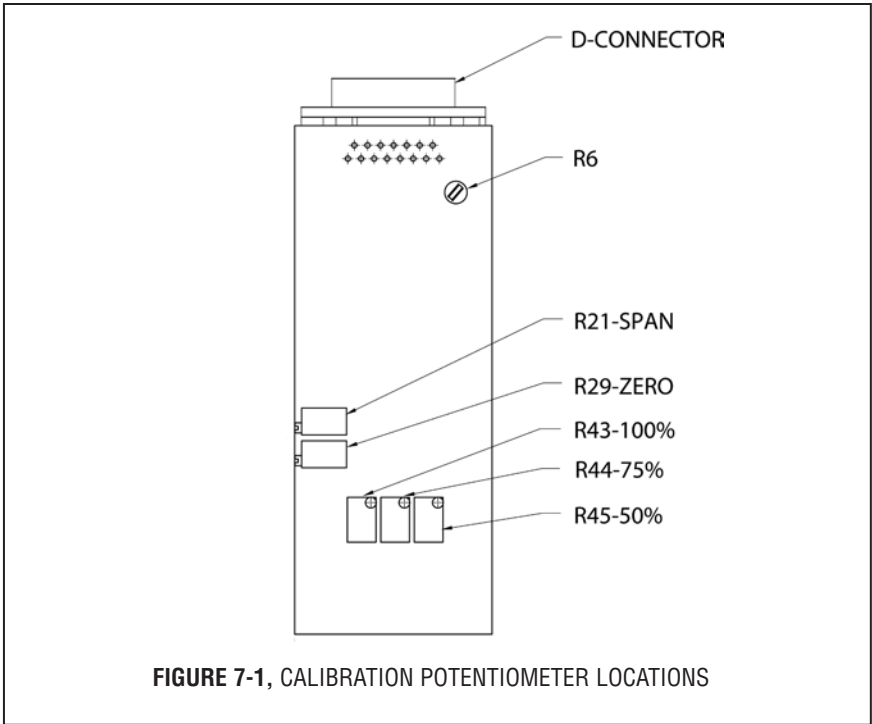

FIGURE 7-1, CALIBRATION POTENTIOMETER LOCATIONS

7.2 Calibration of FMA 1500 Mass Flow Meters

All adjustments in this section are made from the outside of the meter, there is no need to disassemble any part of the instrument.

FMA 1500 Mass Flow Meters may be field recalibrated/checked for the same range they were originally factory calibrated for. When linearity adjustment is needed, or flow range changes are being made proceed to step 7.3. Flow range changes may require a different Restrictor Flow Element (RFE). Additionally, a different Solenoid Valve Orifice for the FMA 1400 Mass Flow Controller (see Table VI) may also be required. Consult Omega® for more information.

7.2.1 Connections and Initial Warm Up

Connect the multimeter to output pins* [2] and [3] of the 15-pin “D” connector for 0-5 VDC (or pins [5] and [15] for optional 4-20 mA) (see Figure 2-3).

* If you are calibrating a Mass Flow Meter System that incorporates a FMA14PD Series Command Module, the multimeter may be connected via the DATA connector which is located at the back of the Command Module.

Power up the Mass Flow Meter for at least 30 minutes prior to commencing the calibration procedure.

7.2.2 ZERO Adjustment

Shut off the flow of gas into the Mass Flow Meter. To ensure that no seepage or leak occurs into the meter, it is good practice to temporarily disconnect the gas source. Using the multimeter and the insulated screwdriver, adjust the ZERO potentiometer [R29] through the access window for 0 VDC (or 4 mA respectively) at zero flow.

7.2.3 SPAN Adjustment

Reconnect the gas source. Using the flow regulator, adjust the flow rate to 100% of full scale flow. Check the flow rate indicated against the flow calibrator. If the deviation is less than $\pm 10\%$ of full scale reading, correct the SPAN potentiometer [R21] setting by using the insulated screwdriver through the access window, to eliminate any deviation. If the deviation is larger than $\pm 10\%$ of full scale reading, a defective condition may be present.

LIKELY REASONS FOR A MALFUNCTIONING SIGNAL MAY BE:

- Occluded or contaminated sensor tube.
- Leaking condition in the FMA 1500 transducer or the gas line and fittings.
- For gases other than nitrogen, recheck appropriate "K" factor from Gas Factor Table.
- Temperature and/or pressure correction errors.

See also section 8 TROUBLESHOOTING. If after attempting to remedy the above conditions, a malfunction still persists, return the meter for factory service, see section 1.1.

At this point the calibration is complete. However, it is advisable that several additional points between 0 and 100%, such as 25%, 50%, and 75% flow be checked. If discrepancies are found, proceed to step 7.3 for Linearity Adjustment.

7.3 Linearity Adjustment

All adjustments in this section are made from the outside of the meter, there is no need to disassemble any part of the instrument.

7.3.1 Connections and Initial Warm Up

Connect the multimeter to output pins* [2] and [3] for 0.5 VDC (or pins [5] and [15] for optional 4-20 mA) (see Figure 2-3).

* If you are calibrating a Mass Flow Meter System that incorporates a FMA14PD Series Command Module, the multimeter may be connected via the DATA connector which is located at the back of the Command Module.

Power up the Mass Flow Meter for at least 30 minutes prior to commencing the calibration procedure.

7.3.2 ZERO Adjustment

Shut off the flow of gas into the Mass Flow Meter. To ensure that no seepage or leak occurs into the meter, it is good practice to temporarily disconnect the gas source. Using the multimeter and the insulated screwdriver, adjust the ZERO potentiometer [R29] through the access window for 0 VDC (or 4 mA respectively) at zero flow.

7.3.3 25% Flow Adjustment

Reconnect the gas source. Using the flow regulator, adjust the flow rate to 25% of full scale flow. Check the flow rate indicated against the flow calibrator. Adjust the setting for potentiometer [R21] by using the insulated screwdriver through the access window, until the output of the flowmeter reads 1.25VDC \pm 37mV (or 8mA \pm 0.12mA).

7.3.4 50% Flow Adjustment

Using the flow regulator, increase the flow rate to 50% of full scale flow. Check the flow rate indicated against the flow calibrator. Adjust the setting for potentiometer [R45] by using the insulated screwdriver through the access window, until the output of the flowmeter reads 2.50VDC \pm 37mV (or 12mA \pm 0.12mA).

7.3.5 75% Flow Adjustment

Increase the flow rate to 75% of full scale flow. Check the flow rate indicated against the flow calibrator. Adjust the setting for potentiometer [R44] by using the insulated screwdriver through the access window, until the output of the flowmeter reads 3.75VDC \pm 37mV (or 16mA \pm 0.12mA).

7.3.6 100% Flow Adjustment

Increase the flow rate to 100% of full scale flow. Check the flow rate indicated against the flow calibrator. Adjust the setting for potentiometer [R43] by using the insulated screwdriver through the access window, until the output of the flowmeter reads 5.00VDC \pm 37mV (or 20mA \pm 0.12mA).

Repeat steps 7.3.3 to 7.3.6 at least once more.

7.4 Calibration of FMA 1400 Mass Flow Controllers

All adjustments in this section are made from the outside of the meter, there is no need to disassemble any part of the instrument.

FMA 1400 Mass Flow Controllers may be field recalibrated/checked for the same range they were originally factory calibrated for.

7.4.1 Disable Solenoid Valve

Remove the round plastic cap on top of the solenoid valve. Turn the set screw on top of the valve counterclockwise until it stops, to open the valve. Set the valve into PURGE mode. This step essentially bypasses the flow control properties of

the transducer. The unit will now act as a mass flow meter.



CAUTION: If the valve is left in the AUTO (control) or OPEN mode for an extended period of time, it may become warm or even hot to the touch. Use care in avoiding direct contact with the valve during operation.

Follow steps outlined in section 7.2 and 7.3, then continue with step 7.4.2 below.

7.4.2 Valve Adjustment

Discontinue the PURGE mode (set valve for the closed position). Apply an inlet pressure of 5 psig, and atmospheric pressure at the outlet. If a small flow occurs, turn the set screw on top of the solenoid valve clockwise until the flow through the FMA 1400 just stops.

7.4.3 Full Scale Flow Adjustment

Fully open the flow regulator upstream of the FMA 1400. Increase the inlet pressure to 20 psig (25 psig for FMA 1400 units above 10 L/min). Apply a +5.00 VDC set point reference. Using the calibrator check the flow rate. If necessary, adjust R21 to match the desired full scale flow rate. [In control mode, turning R21 clockwise will decrease the flow. Conversely, turning R21 counterclockwise will increase the flow through the FMA 1400.]

7.4.4 25% Flow Adjustment

Change the set point to 1.25 VDC to control at 25% of full scale flow. Check the flow rate indicated against the flow calibrator. If the flow rate is not within $\pm 0.75\%$ of full scale, re-adjust the setting for potentiometer [R21], until the flow output is correct.

7.4.5 50% Flow Adjustment

Change the set point to 2.50 VDC to control at 50% of full scale flow. Check the flow rate indicated against the flow calibrator. If the flow rate is not within $\pm 0.75\%$ of full scale, re-adjust the setting for potentiometer [R45], until the flow output is correct.

7.4.6 75% Flow Adjustment

Change the set point to 3.75 VDC to control at 75% of full scale flow. Check the flow rate indicated against the flow calibrator. If the flow rate is not within $\pm 0.75\%$ of full scale, re-adjust the setting for potentiometer [R44], until the flow output is correct.

7.4.7 100% Flow Adjustment

Change the set point to 5.00 VDC to control at 100% of full scale flow. Check the flow rate indicated against the flow calibrator. If the flow rate is not within $\pm 0.75\%$ of full scale, re-adjust the setting for potentiometer [R43], until the flow output is correct.

Repeat steps 7.4.4 to 7.4.7 at least once more.

TABLE VI FMA 1400 SOLENOID VALVE ORIFICE SELECTION TABLE

ORIFICE PART NUMBER	FLOW RATE [N₂]
OR.010	under 10 sccm
OR.020	10 to 1000 sccm
OR.040	1 to 5 slpm
OR.055	5 to 10 slpm
OR.063	10 to 15 slpm
OR.073	15 to 20 slpm
OR.094	20 to 50 slpm
OR.125	50 to 100 slpm

8. TROUBLESHOOTING

8.1 Common Conditions

Your Mass Flow Meter/Controller was thoroughly checked at numerous quality control points during and after manufacturing and assembly operations. It was calibrated in accordance to your desired flow and pressure conditions for a given gas or a mixture of gases.

It was carefully packed to prevent damage during shipment. Should you feel that the instrument is not functioning properly please check for the following common conditions first:

- ✓ Are all cables connected correctly?
- ✓ Are there any leaks in the installation?
- ✓ Is the power supply correctly selected according to requirements?
When several meters are used a power supply with appropriate current rating should be selected.
- ✓ Were the connector pinouts matched properly?
When interchanging with other manufacturers' equipment, cables and connectors must be carefully wired for correct pin configurations.
- ✓ Is the pressure differential across the instrument sufficient?

8.2 Troubleshooting Guide

INDICATION	LIKELY REASON	REMEDY
lack of reading or output	power supply off	check connection of power supply
	fuse blown (FMA 1400/1500)	disconnect FMA 1400/1500 transducer from power supply; remove the shorting condition or check polarities; fuse resets automatically
	fuse blown (FMA14PD Series)	disconnect power cord from AC supply; remove and inspect fuses at AC power input connector of FMA14PD Series; replace as necessary
	filter screen obstructed at inlet	REMOVE CAUSE OF SHORT CIRCUIT!
	occluded sensor tube	flush clean or disassemble to remove impediments or replace flush clean or disassemble to remove impediments or return to factory for replacement
	pc board defect	return to factory for replacement
valve adjustment wrong	re-adjust valve (section 7.4)	
output reads at (+) or (-) saturation only	fuse blown (FMA 1400/1500)	disconnect FMA 1400/1500 transducer from power supply; remove the shorting condition or check polarities; fuse resets automatically REMOVE CAUSE OF SHORT CIRCUIT!
flow reading does not coincide with the set point (FMA 1400 models only)	inadequate gas pressure	apply appropriate gas pressure
	filter screen obstructed at inlet	flush clean or disassemble to remove impediments or replace
	ground loop	signal and power supply commons are different
no response to set point (FMA 1400 models only)	inadequate gas pressure	apply appropriate gas pressure
	cable or connector malfunction	check cables and all connections or replace
	set point is too low (<2% of full scale)	re-adjust set point
	valve adjustment wrong	re-adjust valve (section 7.4)

INDICATION	LIKELY REASON	REMEDY
unstable or no zero reading	gas leak pc board defective	locate and correct return to factory for replacement
full scale output at "no flow" condition or with valve closed	defective sensor gas Leak	return to factory for replacement locate and repair
calibration off	gas metered is not the same as what meter was calibrated for composition of gas changed gas leak pc board defective RFE dirty occluded sensor tube filter screen obstructed at inlet transducer is not mounted properly	use matched calibration see K factor tables in APPENDIX 2 locate and correct return to factory for replacement flush clean or disassemble to remove impediments flush clean or disassemble to remove impediments or return to factory for replacement flush clean or disassemble to remove impediments or replace check for any tilt or change in the mounting of the transducer; generally, units are calibrated for horizontal installation (relative to the sensor tube)
FMA 1400 valve does not work in open position	incorrect valve adjustment pc board defect cable or connectors malfunction differential pressure too high insufficient inlet pressure	re-adjust valve (section 7.4) return to factory for replacement check cable and connectors or replace decrease pressure to correct level adjust appropriately
FMA 1400 valve does not work in close position	incorrect valve adjustment pc board defect cable or connectors malfunction orifice obstructed	re-adjust valve (section 7.4) return to factory for replacement check cable and connectors or replace disassemble to remove impediments or return to factory

For best results it is recommended that instruments are returned to the factory for servicing. See section 1.3 for return procedures.

8.3 Technical Assistance

Omega® Engineering will provide technical assistance over the phone to qualified repair personnel. Please call our Flow Department (800) 872-9436 extension 2298.

9. CALIBRATION CONVERSIONS FROM REFERENCE GASES

The calibration conversion incorporates the K factor. The K factor is derived from gas density and coefficient of specific heat. For diatomic gases:

$$K_{\text{gas}} = \frac{1}{d \times C_p}$$

where d = gas density (gram/liter)

C_p = coefficient of specific heat (cal/gram)

Note in the above relationship that d and C_p are usually chosen at standard conditions of one atmosphere and 25° C.

If the flow range of a Mass Flow Controller or Controller remains unchanged, a relative K factor is used to relate the calibration of the actual gas to the reference gas.

$$K = \frac{Q_a}{Q_r} = \frac{K_a}{K_r}$$

where Q_a = mass flow rate of an actual gas (sccm)

Q_r = mass flow rate of a reference gas (sccm)

K_a = K factor of an actual gas

K_r = K factor of a reference gas

For example, if we want to know the flow rate of oxygen and wish to calibrate with nitrogen at 1000 SCCM, the flow rate of oxygen is:

$$Q_{O_2} = Q_a = Q_r \times K = 1000 \times 0.9926 = 992.6 \text{ sccm}$$

where K = relative K factor to reference gas (oxygen to nitrogen)

APPENDIX 1

COMPONENTS DIAGRAMS

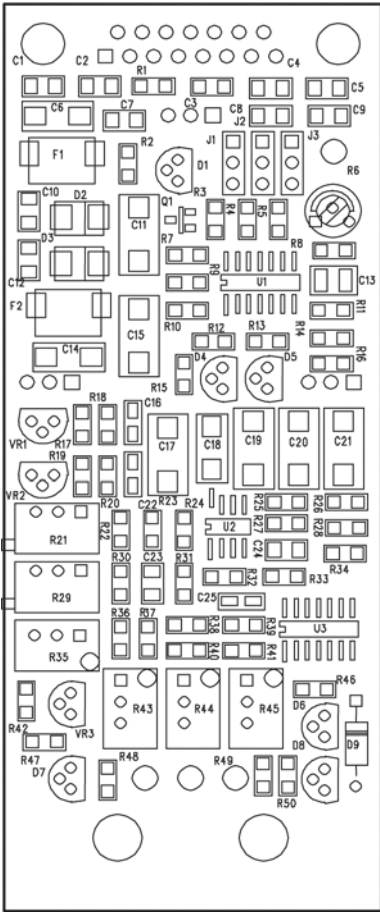

FMA 1500 METERING PC BOARD
(ALSO INCORPORATED IN FMA 1400)

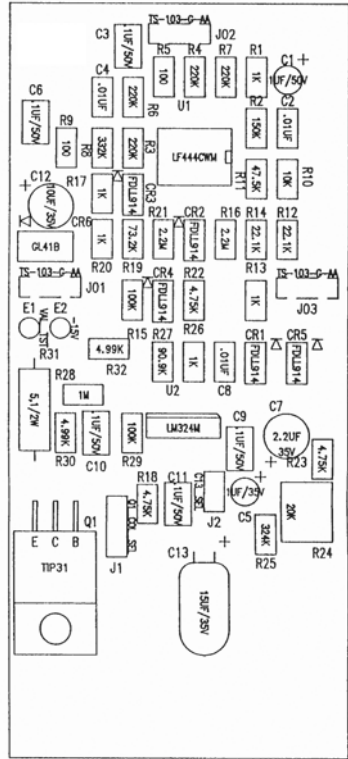

FMA 1400 CONTROL PC BOARD

APPENDIX 2

GAS FACTOR TABLE ("K" FACTORS)

ACTUAL GAS	K FACTOR Relative to N ₂	Cp [Cal/g]	Density [g/l]
Acetylene C ₂ H ₂	.5829	.4036	1.162
Air	1.0000	.240	1.293
Allene (Propadiene) C ₃ H ₄	.4346	.352	1.787
Ammonia NH ₃	.7310	.492	.760
Argon Ar	1.4573	.1244	1.782
Arsine AsH ₃	.6735	.1167	3.478
Boron Trichloride BCl ₃	.4089	.1279	5.227
Boron Trifluoride BF ₃	.5082	.1778	3.025
Bromine Br ₂	.8083	.0539	7.130
Boron Tribromide Br ₃	.38	.0647	11.18
Bromine Pentafluoride BrF ₅	.26	.1369	7.803
Bromine Trifluoride BrF ₃	.3855	.1161	6.108
Bromotrifluoromethane (Freon-13 B1) CBrF ₃	.3697	.1113	6.644
1,3-Butadiene C ₄ H ₆	.3224	.3514	2.413
Butane C ₄ H ₁₀	.2631	.4007	2.593
1-Butane C ₄ H ₈	.2994	.3648	2.503
2-Butane C ₄ H ₈ CIS	.324	.336	2.503
2-Butane C ₄ H ₈ TRANS	.291	.374	2.503
Carbon Dioxide CO ₂	.7382	.2016	1.964
Carbon Disulfide CS ₂	.6026	.1428	3.397
Carbon Monoxide C ₀	1.00	.2488	1.250
Carbon Tetrachloride CCl ₄	.31	.1655	6.860
Carbon Tetrafluoride (Freon-14)CF ₄	.42	.1654	3.926
Carbonyl Fluoride COF ₂	.5428	.1710	2.945
Carbonyl Sulfide COS	.6606	.1651	2.680
Chlorine Cl ₂	.86	.114	3.163
Chlorine Trifluoride ClF ₃	.4016	.1650	4.125
Chlorodifluoromethane (Freon-22)CHClF ₂	.4589	.1544	3.858
Chloroform CHCl ₃	.3912	.1309	5.326
Chloropentafluoroethane(Freon-115)C ₂ ClF ₅	.2418	.164	6.892
Chlorotrifluoromethane (Freon-13) CClF ₃	.3834	.153	4.660
CyanogenC ₂ N ₂	.61	.2613	2.322
CyanogenChloride ClCN	.6130	.1739	2.742
Cyclopropane C ₃ H ₅	.4584	.3177	1.877
Deuterium D ₂	1.00	1.722	1.799
Diborane B ₂ H ₆	.4357	.508	1.235

ACTUAL GAS	K Factor Relative to N ₂	Cp [Cal/g]	Density [g/l]
Dibromodifluoromethane CBr ₂ F ₂	.1947	.15	9.362
Dichlorodifluoromethane (Freon-12) CCl ₂ F ₂	.3538	.1432	5.395
Dichlorofluoromethane (Freon-21) CHCl ₂ F	.4252	.140	4.592
Dichloromethylsilane (CH ₃) ₂ SiCl ₂	.2522	.1882	5.758
Dichlorosilane SiH ₂ Cl ₂	.4044	.150	4.506
Dichlorotetrafluoroethane (Freon-114) C ₂ Cl ₂ F ₄	.2235	.1604	7.626
1,1-Difluoroethylene (Freon-1132A) C ₂ H ₂ F ₂	.4271	.224	2.857
Dimethylamine (CH ₃) ₂ NH	.3714	.366	2.011
Dimethyl Ether (CH ₃) ₂ O	.3896	.3414	2.055
2,2-Dimethylpropane C ₃ H ₁₂	.2170	.3914	3.219
Ethane C ₂ H ₆	.50	.420	1.342
Ethanol C ₂ H ₆ O	.3918	.3395	2.055
Ethyl Acetylene C ₄ H ₆	.3225	.3513	2.413
Ethyl Chloride C ₂ H ₅ Cl	.3891	.244	2.879
Ethylene C ₂ H ₄	.60	.365	1.251
Ethylene Oxide C ₂ H ₄ O	.5191	.268	1.965
Fluorine F ₂	.9784	.1873	1.695
Fluoroform (Freon-23) CHF ₃	.4967	.176	3.127
Freon-11 CCl ₃ F	.3287	.1357	6.129
Freon-12 CCl ₂ F ₂	.3538	.1432	5.395
Freon-13 CClF ₃	.3834	.153	4.660
Freon-13B1 CBrF ₃	.3697	.1113	6.644
Freon-14 CF ₄	.4210	.1654	3.926
Freon-21 CHCl ₂ F	.4252	.140	4.592
Freon-22 CHClF ₂	.4589	.1544	3.858
Freon-113 CCl ₂ FCClF ₂	.2031	.161	8.360
Freon-114 C ₂ Cl ₂ F ₄	.2240	.160	7.626
Freon-115 C ₂ ClF ₅	.2418	.164	6.892
Freon-C318 C ₄ F ₆	.1760	.185	8.397
Germane GeH ₄	.5696	.1404	3.418
Germanium Tetrachloride GeCl ₄	.2668	.1071	9.565
Helium He	1.454	1.241	.1786
Hexafluoroethane C ₂ F ₆ (Freon-116)	.2421	.1834	6.157
Hexane C ₆ H ₁₄	.1792	.3968	3.845
Hydrogen H ₂	1.0106	3.419	.0899
Hydrogen Bromide HBr	1.000	.0861	3.610
Hydrogen Chloride HCl	1.000	.1912	1.627
Hydrogen Cyanide HCN	1.070	.3171	1.206

Actual Gas	K Factor Relative to N ₂	Cp [Cal/g]	Density [g/l]
Hydrogen Fluoride HF	.9998	.3479	.893
Hydrogen Iodide HI	.9987	.0545	5.707
Hydrogen Selenide H ₂ Se	.7893	.1025	3.613
Hydrogen Sulfide H ₂ S	.80	.2397	1.520
Iodine Pentafluoride IF ₅	.2492	.1108	9.90
Isobutane CH(CH ₃) ₃	.27	.3872	3.593
Isobutylene C ₄ H ₆	.2951	.3701	2.503
Krypton Kr	1.453	.0593	3.739
Methane CH ₄	.7175	.5328	.715
Methanol CH ₃	.5843	.3274	1.429
Methyl Acetylene C ₃ H ₄	.4313	.3547	1.787
Methyl Bromide CH ₂ Br	.5835	.1106	4.236
Methyl Chloride CH ₃ Cl	.6299	.1926	2.253
Methyl Fluoride CH ₃ F	.68	.3221	1.518
Methyl Mercaptan CH ₃ SH	.5180	.2459	2.146
Methyl Trichlorosilane (CH ₃)SiCl ₃	.2499	.164	6.669
Molybdenum Hexafluoride MoF ₆	.2126	.1373	9.366
Monoethylamine C ₂ H ₅ NH ₂	.3512	.387	2.011
Monomethylamine CH ₃ NH ₂	.51	.4343	1.386
Neon NE	1.46	.246	.900
Nitric Oxide NO	.990	.2328	1.339
Nitrogen N ₂	1.000	.2485	1.25
Nitrogen Dioxide NO ₂	.737	.1933	2.052
Nitrogen Trifluoride NF ₃	.4802	.1797	3.168
Nitrosyl Chloride NOCl	.6134	.1632	2.920
Nitrous Oxide N ₂ O	.7128	.2088	1.964
Octafluorocyclobutane (Freon-C318) C ₄ F ₆	.176	.185	8.397
Oxygen O ₂	.9926	.2193	1.427
Oxygen Difluoride OF ₂	.6337	.1917	2.406
Ozone	.446	.195	2.144
Pentaborane B ₅ H ₉	.2554	.38	2.816
Pentane C ₅ H ₁₂	.2134	.398	3.219
Perchloryl Fluoride ClO ₃ F	.3950	.1514	4.571
Perfluoropropane C ₃ F ₈	.174	.197	8.388
Phosgene COCl ₂	.4438	.1394	4.418
Phosphine PH ₃	1.070	.2374	1.517
Phosphorous Oxychloride POCl ₃	.36	.1324	6.843
Phosphorous Pentafluoride PF ₅	.3021	.1610	5.620

Actual Gas	K Factor Relative to N ₂	Cp [Cal/g]	Density [g/l]
Phosphorous Trichloride PCl ₃	.30	.1250	6.127
Propane C ₃ H ₈	.35	.399	1.967
Propylene C ₃ H ₆	.40	.366	1.877
Silane SiH ₄	.5982	.3189	1.433
Silicon Tetrachloride SiCl ₄	.284	.1270	7.580
Silicon Tetrafluoride SiF ₄	.3482	.1691	4.643
Sulfur Dioxide SO ₂	.69	.1488	2.858
Sulfur Hexafluoride SF ₆	.2635	.1592	6.516
Sulfuryl Fluoride SO ₂ F ₂	.3883	.1543	4.562
Tetrafluoroethane (Forane 134A) CF ₃ CH ₂ F	.5096	.127	4.224
Tetrafluorohydrazine N ₂ F ₄	.3237	.182	4.64
Trichlorofluoromethane (Freon-11) CCl ₃ F	.3287	.1357	6.129
Trichlorosilane SiHCl ₃	.3278	.1380	6.043
1,1,2-Trichloro-1,2,2 Trifluoroethane (Freon-113) CCl ₂ CClF ₂	.2031	.161	8.36
Triisobutyl Aluminum (C ₄ H ₉) ₃ Al	.0608	.508	8.848
Titanium Tetrachloride TiCl ₄	.2691	.120	8.465
Trichloro Ethylene C ₂ HCl ₃	.32	.163	5.95
Trimethylamine (CH ₃) ₃ N	.2792	.3710	2.639
Tungsten Hexafluoride WF ₆	.2541	.0810	13.28
Uranium Hexafluoride UF ₆	.1961	.0888	15.70
Vinyl Bromide CH ₂ CHBr	.4616	.1241	4.772
Vinyl Chloride CH ₂ CHCl	.48	.12054	2.788
Xenon Xe	1.44	.0378	5.858

APPENDIX 3

DIMENSIONAL DRAWINGS

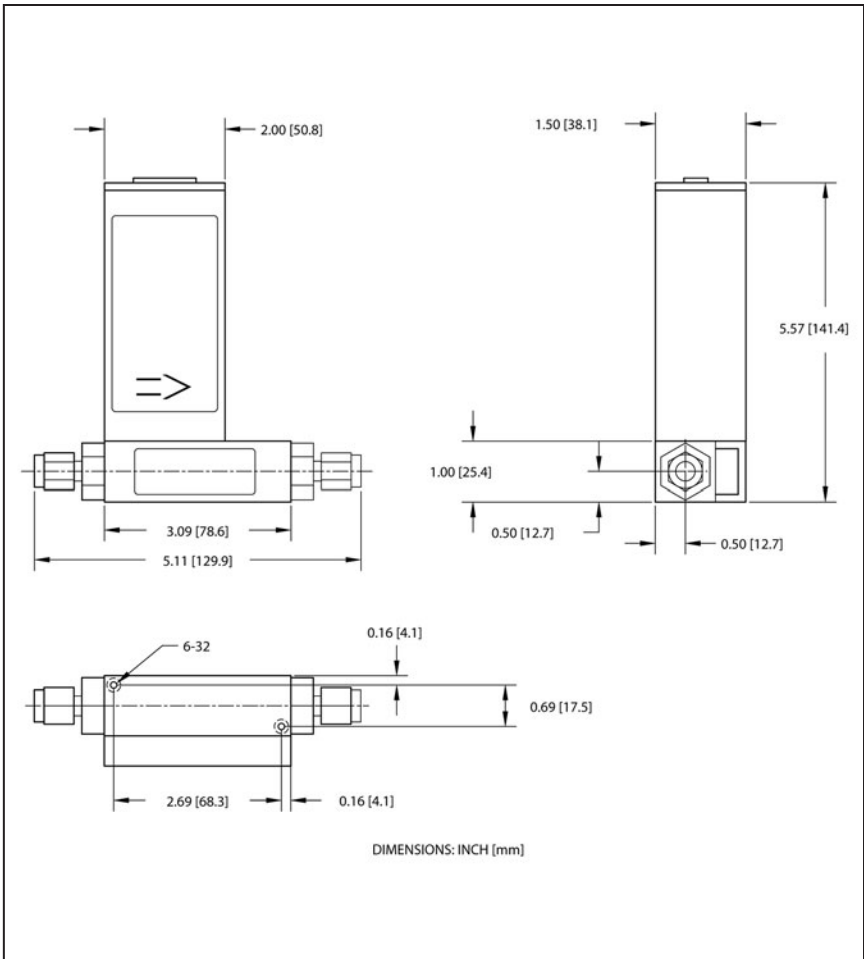

**FMA 1500 FOR RANGES UP TO 10 L/MIN
MASS FLOW METER**

NOTES: Omega® reserves the right to change designs and dimensions at its sole discretion at any time without notice. For certified dimensions please contact Omega®.

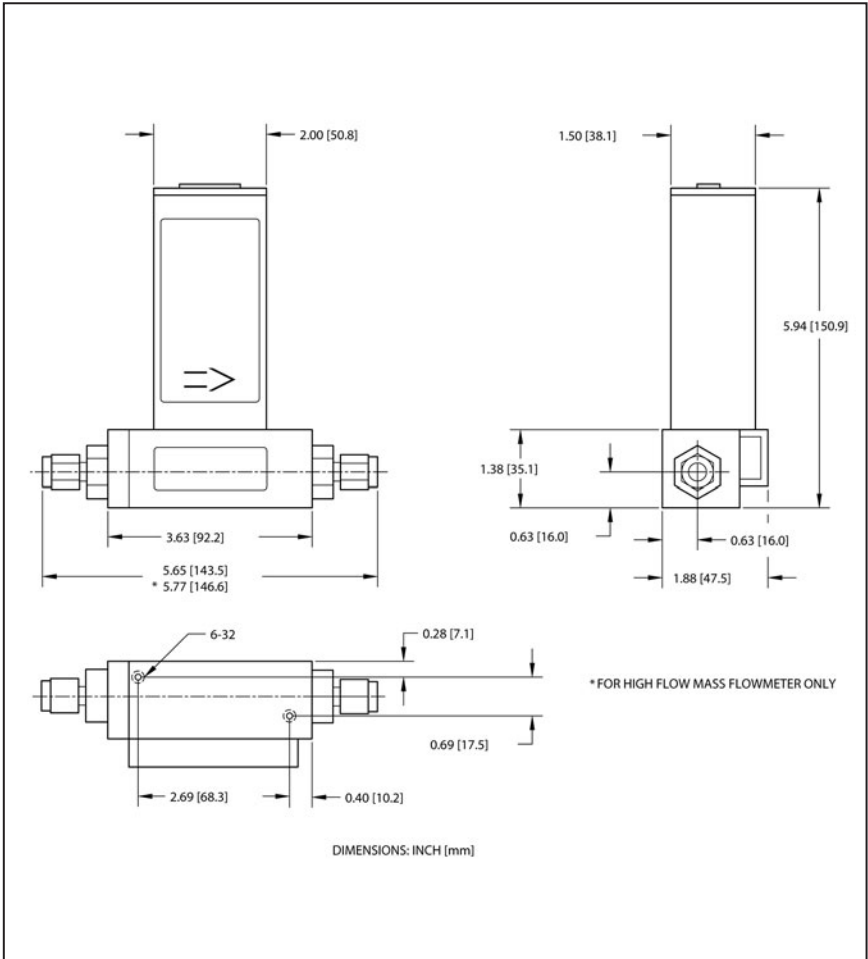

**FMA 1500 FOR RANGES ABOVE 10 L/MIN
MASS FLOW CONTROLLER**

NOTES: Omega® reserves the right to change designs and dimensions at its sole discretion at any time without notice. For certified dimensions please contact Omega®.

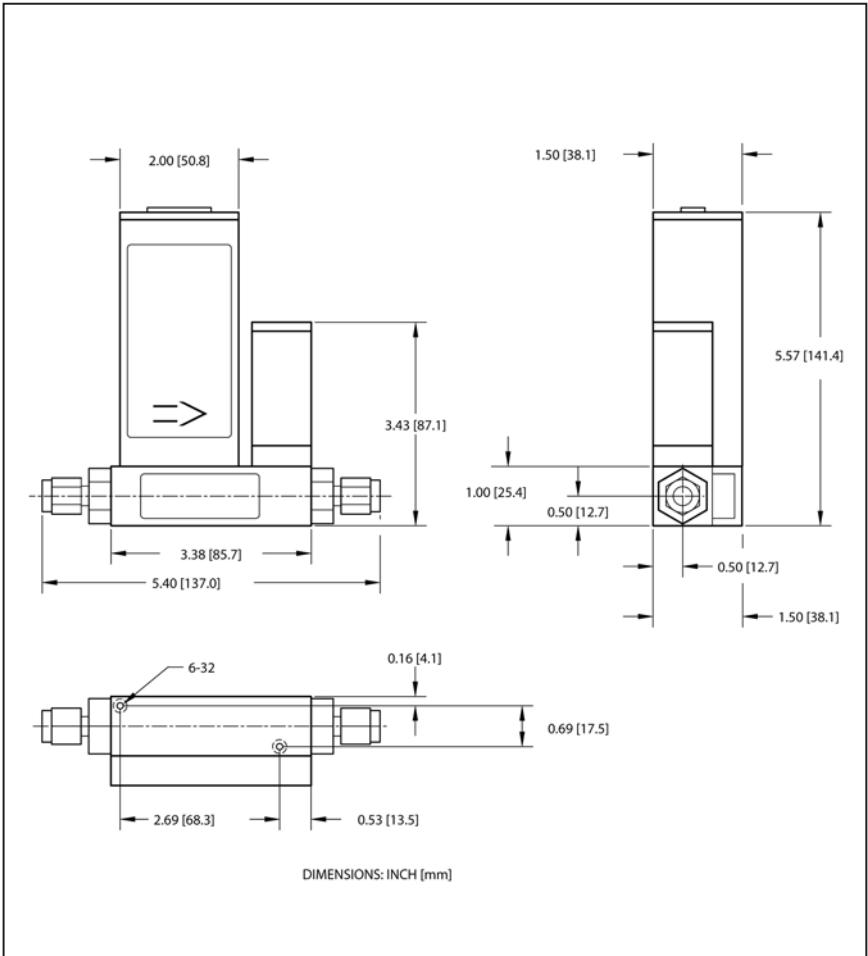

**FMA 1400 RANGES UP TO 10 L/MIN
MASS FLOW CONTROLLER**

NOTES: Omega® reserves the right to change designs and dimensions at its sole discretion at any time without notice. For certified dimensions please contact Omega®.

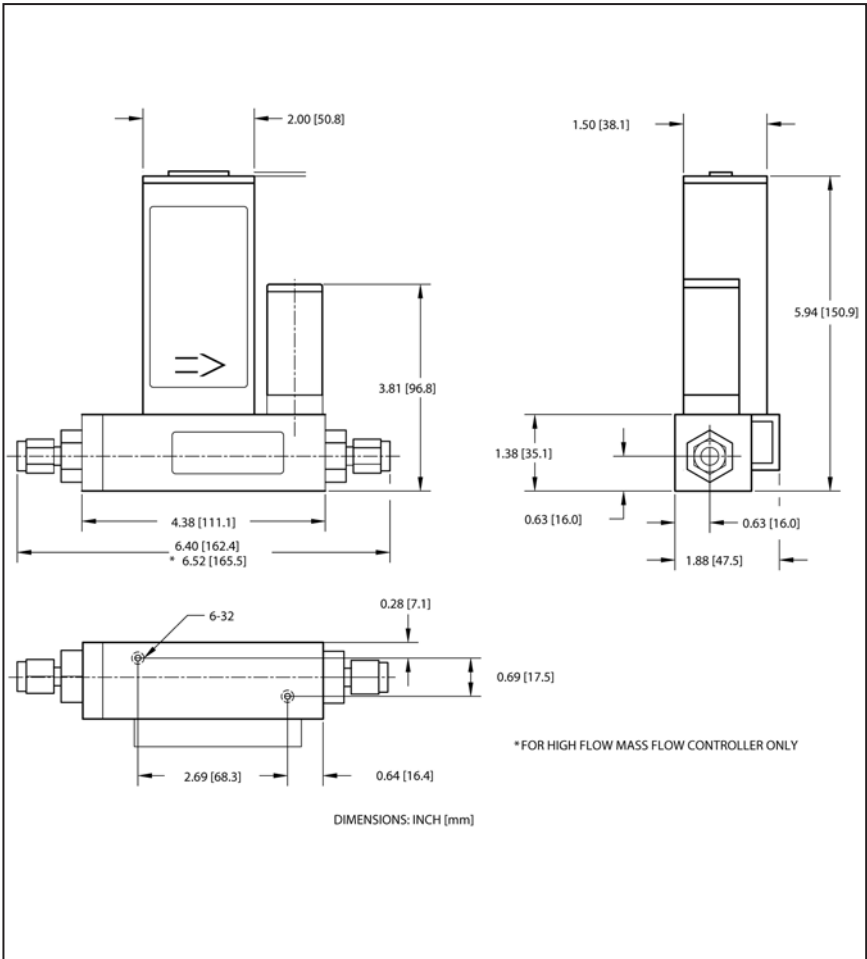

**FMA 1400 RANGES ABOVE 10 L/MIN
MASS FLOW CONTROLLER**

NOTES: Omega® reserves the right to change designs and dimensions at its sole discretion at any time without notice. For certified dimensions please contact Omega®.

NOTES:

NOTES:



WARRANTY/DISCLAIMER

OMEGA ENGINEERING, INC. warrants this unit to be free of defects in materials and workmanship for a period of **13 months** from date of purchase. OMEGA's Warranty adds an additional one (1) month grace period to the normal one **(1) year product warranty** to cover handling and shipping time. This ensures that OMEGA's customers receive maximum coverage on each product.

If the unit malfunctions, it must be returned to the factory for evaluation. OMEGA's Customer Service Department will issue an Authorized Return (AR) number immediately upon phone or written request. Upon examination by OMEGA, if the unit is found to be defective, it will be repaired or replaced at no charge. OMEGA's WARRANTY does not apply to defects resulting from any action of the purchaser, including but not limited to mishandling, improper interfacing, operation outside of design limits, improper repair, or unauthorized modification. This WARRANTY is VOID if the unit shows evidence of having been tampered with or shows evidence of having been damaged as a result of excessive corrosion; or current, heat, moisture or vibration; improper specification; misapplication; misuse or other operating conditions outside of OMEGA's control. Components which wear are not warranted, including but not limited to contact points, fuses, and triacs.

OMEGA is pleased to offer suggestions on the use of its various products. However, OMEGA neither assumes responsibility for any omissions or errors nor assumes liability for any damages that result from the use of its products in accordance with information provided by OMEGA, either verbal or written. OMEGA warrants only that the parts manufactured by it will be as specified and free of defects. OMEGA MAKES NO OTHER WARRANTIES OR REPRESENTATIONS OF ANY KIND WHATSOEVER, EXPRESS OR IMPLIED, EXCEPT THAT OF TITLE, AND ALL IMPLIED WARRANTIES INCLUDING ANY WARRANTY OF MERCHANTABILITY AND FITNESS FOR A PARTICULAR PURPOSE ARE HEREBY DISCLAIMED. LIMITATION OF LIABILITY: The remedies of purchaser set forth herein are exclusive, and the total liability of OMEGA with respect to this order, whether based on contract, warranty, negligence, indemnification, strict liability or otherwise, shall not exceed the purchase price of the component upon which liability is based. In no event shall OMEGA be liable for consequential, incidental or special damages.

CONDITIONS: Equipment sold by OMEGA is not intended to be used, nor shall it be used: (1) as a "Basic Component" under 10 CFR 21 (NRC), used in or with any nuclear installation or activity; or (2) in medical applications or used on humans. Should any Product(s) be used in or with any nuclear installation or activity, medical application, used on humans, or misused in any way, OMEGA assumes no responsibility as set forth in our basic WARRANTY/DISCLAIMER language, and, additionally, purchaser will indemnify OMEGA and hold OMEGA harmless from any liability or damage whatsoever arising out of the use of the Product(s) in such a manner.

RETURN REQUESTS/INQUIRIES

Direct all warranty and repair requests/inquiries to the OMEGA Customer Service Department. BEFORE RETURNING ANY PRODUCT(S) TO OMEGA, PURCHASER MUST OBTAIN AN AUTHORIZED RETURN (AR) NUMBER FROM OMEGA'S CUSTOMER SERVICE DEPARTMENT (IN ORDER TO AVOID PROCESSING DELAYS). The assigned AR number should then be marked on the outside of the return package and on any correspondence.

The purchaser is responsible for shipping charges, freight, insurance and proper packaging to prevent breakage in transit.

FOR **WARRANTY** RETURNS, please have the following information available BEFORE contacting OMEGA:

1. Purchase Order number under which the product was PURCHASED,
2. Model and serial number of the product under warranty, and
3. Repair instructions and/or specific problems relative to the product.

FOR **NON-WARRANTY** REPAIRS, consult OMEGA for current repair charges. Have the following information available BEFORE contacting OMEGA:

1. Purchase Order number to cover the COST of the repair,
2. Model and serial number of the product, and
3. Repair instructions and/or specific problems relative to the product.

OMEGA's policy is to make running changes, not model changes, whenever an improvement is possible. This affords our customers the latest in technology and engineering.

OMEGA is a registered trademark of OMEGA ENGINEERING, INC.

© Copyright 2001 OMEGA ENGINEERING, INC. All rights reserved. This document may not be copied, photocopied, reproduced, translated, or reduced to any electronic medium or machine-readable form, in whole or in part, without the prior written consent of OMEGA ENGINEERING, INC.

Where Do I Find Everything I Need for Process Measurement and Control? **OMEGA...Of Course!**

Shop online at www.omega.com

TEMPERATURE

- ☑ Thermocouple, RTD & Thermistor Probes, Connectors, Panels & Assemblies
- ☑ Wire: Thermocouple, RTD & Thermistor
- ☑ Calibrators & Ice Point References
- ☑ Recorders, Controllers & Process Monitors
- ☑ Infrared Pyrometers

PRESSURE, STRAIN AND FORCE

- ☑ Transducers & Strain Gages
- ☑ Load Cells & Pressure Gages
- ☑ Displacement Transducers
- ☑ Instrumentation & Accessories

FLOW/LEVEL

- ☑ Rotameters, Gas Mass Flow meter & Flow Computers
- ☑ Air Velocity Indicators
- ☑ Turbine/Paddlewheel Systems
- ☑ Totalizers & Batch Controllers

pH/CONDUCTIVITY

- ☑ pH Electrodes, Testers & Accessories
- ☑ Benchtop/Laboratory Meters
- ☑ Controllers, Calibrators, Simulators & Pumps
- ☑ Industrial pH & Conductivity Equipment

DATA ACQUISITION

- ☑ Data Acquisition & Engineering Software
- ☑ Communications-Based Acquisition Systems
- ☑ Plug-in Cards for Apple, IBM & Compatibles
- ☑ Datalogging Systems
- ☑ Recorders, Printers & Plotters

HEATERS

- ☑ Heating Cable
- ☑ Cartridge & Strip Heaters
- ☑ Immersion & Band Heaters
- ☑ Flexible Heaters
- ☑ Laboratory Heaters

ENVIRONMENTAL MONITORING AND CONTROL

- ☑ Metering & Control Instrumentation
- ☑ Refractometers
- ☑ Pumps & Tubing
- ☑ Air, Soil & Water Monitors
- ☑ Industrial Water & Wastewater Treatment
- ☑ pH, Conductivity & Dissolved Oxygen Instruments