

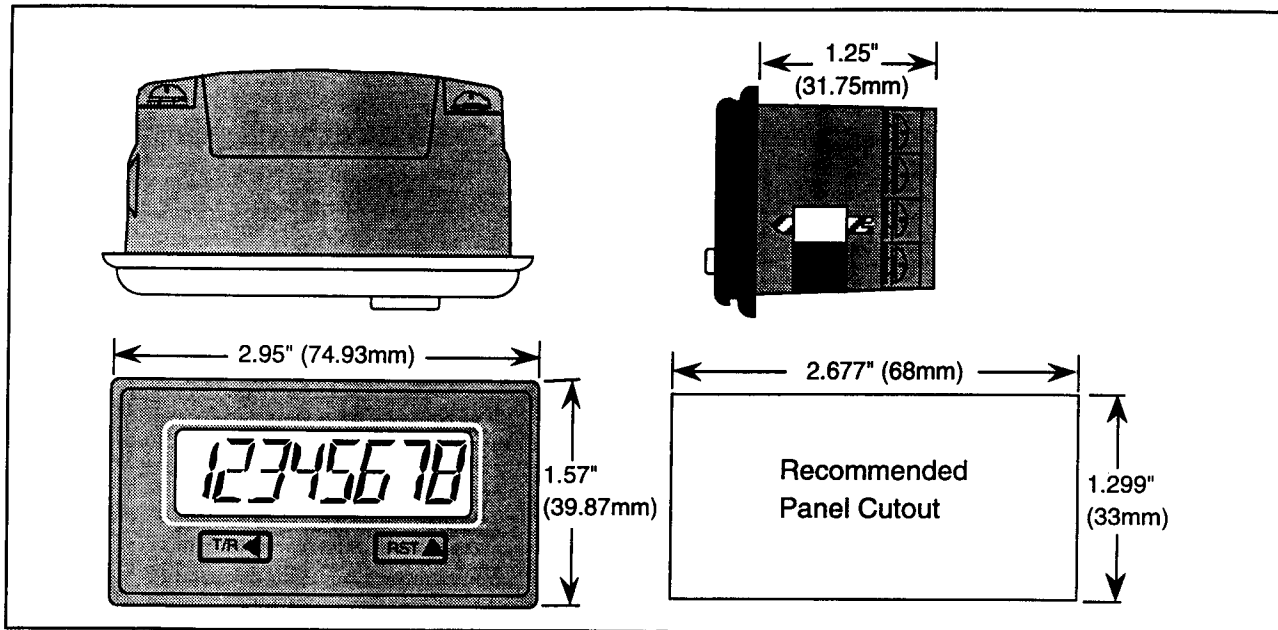

DPC10-RT Ratemeter/Totalizer

M1666/0693



POWER

Internal battery: 3V, lithium
Life expectancy: 5 years +
Replacement Part: DPC10-BAT

PHYSICAL

Operation Temperature: 0° - 55°C
Storage Temperature: -20° - 70°C
Operating Humidity: 90% Non-condensing
Weight: 2.2 oz. net
Display Size: .43" high
Front Panel Rating: NEMA-4X when mounted with gasket provided
Case Material: Cynolac X-17

TOTALIZER

Type: UP counting
Digits: 8
Scaler: 0.0001 - 100.0000
(0.0000 scales by 100)
Decimal Point: 5 positions, programmable

RATE INDICATOR

Type: 1/Tau
Digits: 4/5 (4 calculated, 5 displayed with fixed 0 in LSD)
Scaler Range: .001 to 9999
Decimal Point: 5 positions, programmable
Accuracy: ±0.2%
Update Time: 0.7 sec
Zero Time: 10 seconds

DC COMMON (Terminal 1)

COUNT/RATE INPUTS

Input B (Terminal 2) Low speed input designed for contact closures to dc common

Speed: 0 to 20 Hz
Minimum Low Time: 10 milliseconds
Minimum High Time: 40 milliseconds
Impedance: 101K ohm
Voltage Thresholds: Low 0 to 0.4 V dc
High 2.0 to 28 V dc
Maximum High 28 V dc

Input A (Terminal 3) High speed input requiring a voltage source such as a current sourcing sensor or a current sinking sensor used with the provided pull up resistors.

Speed: 0 to 10 kHz
Minimum Low Time: 80 microseconds
Minimum High Time: 20 microseconds
(The above times are with a 0 to 5.0 V swing)
Input Impedance: 2kΩ above 5 V dc
Voltage Thresholds: Low 0 to 1.2 V dc
High 2.0 to 28 V dc
Maximum High 28 V dc

RESET INPUT (Terminal 4)

Resets totalizer to zero when connected to dc common

Minimum Low Time: 0.25 to 1.0 seconds (maintained)
The required pulse width varies with count speed, scale factor and number of digits displayed.
Voltage Thresholds: Low 0 to 0.4 V dc
High 2.0 to 28 V dc

PROGRAM ENABLE INPUT (Terminal 5)

Operation: Level sensitive (maintained)

COUNT ACCURACY

100% when operated within specifications

INTRODUCTION

The OMEGA DPC10-RT is a combination UP counting totalizer and ratemeter. The totalizer has an eight digit display. The front-panel reset key can be disabled. A remote-reset terminal is provided. The count scaler and decimal point can be programmed.

The ratemeter has a 4-5 digit LCD display. The four most significant digits are calculated; five digits will be displayed with fixed 0 in the least significant digit. A programmable rate scaler and decimal point allow for display of rate in any engineering terms.

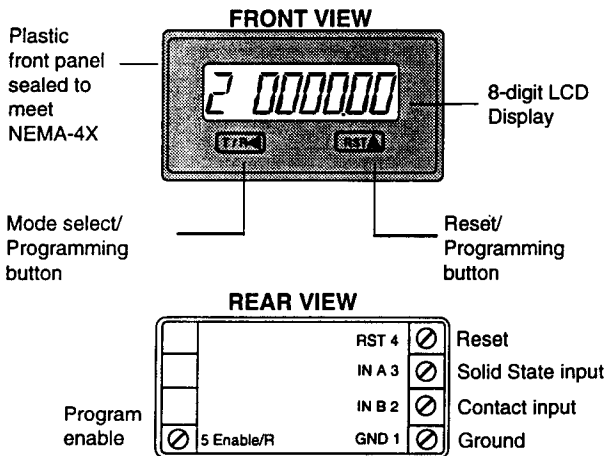

APPLICATIONS

The DPC10-RT is designed to show both total and process rate. You must make certain programming and wiring decisions to complete your application. We recommend the following sequence:

1. Answer the following questions:
 - What type of sensor will be used?
 - What engineering units should the ratemeter be scaled to?
 - How many pulses per item is the sensor providing?
 - Is a decimal point needed on the count and/or rate display?
 - Should the front-panel reset key be active or inactive?
2. Calculate the count scale factor and the rate scale factor.

MOUNTING

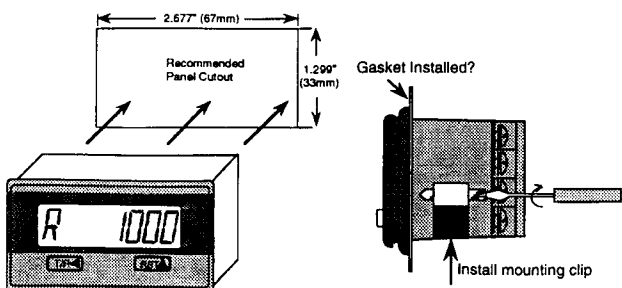

OPERATION

Count Inputs

Separate contact and solid state count inputs are provided. The solid state input (terminal 3) requires a current-sourcing sensor and can count up to 10 kHz. Inputs into this terminal are counted on the positive-going edge.

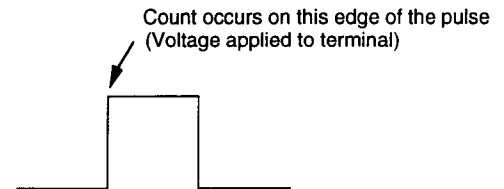

Terminal 3 is pulled down to common. When a sensor output supplies voltage to this terminal, one count is registered on the display. The sourcing signal must supply at least +2.0 V dc but no more than +28 V dc.

Note: When a sourcing signal is applied to terminal 3, a power assist feature of the DPC10-RT extends the life of the battery.

Terminal 2 is the low-speed, current sinking count input designed to be used with a contact closure to ground. It has a maximum count speed of 20 Hz. Inputs into this terminal are counted on the negative-going edge.

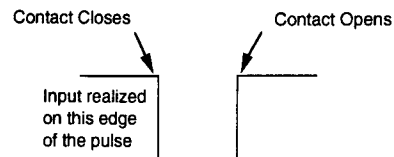

Terminal 2 is pulled up to +3 V dc. When a contact closes, pulling the voltage down to .4 V dc or less, one count is registered.

RUN MODE

Screens

Two screens are available on the DPC10-RT.

Totalizer: This 8-digit screen shows you the accumulated scaled count inputs. The totalizer has lead-zero blanking.

Ratemeter: This 4-5 digit screen shows current process rate.

Front Panel Keys

Press the **T/R** key on the front panel to toggle between the totalizer and ratemeter screens.

Press the **RST** key to reset the totalizer display to zero. This button has no effect on the ratemeter screen.

The front panel reset key provides an edge-sensitive (momentary) reset.

Note: The **RST** key may be disabled. See program mode.

PROGRAM MODE

NOTE: To enter the program mode, you must connect a jumper between terminals 1 and 5. To leave the program mode, disconnect the jumper.

Screens

There are six program-mode screens in the DPC10-RT. Press and hold the **T/R** key while repeatedly pressing the

RST key to advance to successive screens.

Programming Screens	
Screen	Function
1	Count Scale Factor
2	Totalizer Decimal Point
3	Rate Scale Factor
4	Ratemeter Decimal Point
5	Rate x1/x10
6	Reset Key Enable/Disable

COUNT SCALER

Calculating the Count Scale Factor

The count scale factor is used to convert the incoming count pulses to the desired unit of measure to be displayed (feet, gallons, etc.) or to correct for a known amount of error (wheel wear, viscosity, etc.). This scaler has six digits available with a fixed decimal point.

Count Scaler Range: 0.0001 to 99.9999

Count Scaler (CS) Formula:

$$CS = \frac{DPF}{PPI}$$

where:

DPF is the decimal point factor corresponding to the desired decimal point location.

DISPLAY	DPF	DISPLAY	DPF
XXXXXX	= 1	XXX.XXX	= 1,000
XXXXX.X	= 10	XX.XXXX	= 10,000
XXXX.XX	= 100		

PPI is the number of pulses per item from the sensor (times 2 if doubled count mode).

Example 1: A sensor produces 20 pulses per inch of material travel. Calculate the count scaler required to indicate material used in whole inches (XXXXXX).

$$CS = \frac{1}{20} = 0.05000$$

Example 2: An encoder produces 120 pulses per foot. Calculate the count scaler required to indicate material usage in 1/100's of feet (XXXX.XX).

$$CS = \frac{100}{120} = 0.8333$$

(Select the XXXX.XX position on the totalizer decimal point menu).

Programming Count Scale Factor

The first screen in the program mode is used to enter the count scale factor.

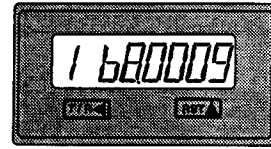

The far right digit will be flashing. Press the **RST** key until reaching the desired digit value.

Note: Pressing and holding the **RST** key will cause the numbers to autoscroll.

Next press the **T/R** key to move the flashing digit one place to the left. Change this digit to the desired value with the **RST** key.

Repeat this process until all digits are set correctly.

(Setting the count scale factor to 0.0000 will allow scaling by 100)

Programming Totalizer Decimal Point

The second screen is used to enter the decimal point display on the totalizer screen. Press and hold the **T/R** key and then press the **RST** key to move from screen one to screen two.

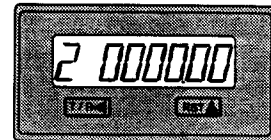

Press the **RST** key to move the decimal point to the desired position.

RATE SCALER

Calculating the Rate Scale Factor

This 1/Tau ratemeter calculates rate by measuring the time interval between input pulses, converting to a frequency ($F = 1/\text{Tau}$), and multiplying the product by the rate scaler. The rate scaler is user programmed to convert the count input frequency into the desired rate units for display (feet/minute, inches/second, gallons/hour, etc.)

Rate Scaler Range: 0.001 to 9999

Rate Scaler (RS) formula:

$$RS = \frac{\text{Sec} \times \text{DPF}}{\text{PPI} \times 10} \text{ for } R \times 10$$

where:

SEC is the number of seconds in the rate time unit (items/second = 1, items/minute = 60, items/hour = 3600, etc.)

DPF is the decimal point factor corresponding to the desired decimal point location on the run mode screen:

Display	DPF
XXXX	1
XXX.X	10
XX.XX	100
X.XXX	1000

PPI is the number of pulses per item from the sensor.

Example 1: A sensor produces 10 pulses per foot of material travel. Display rate in whole feet per minute (XXXX).

$$RS = \frac{60 \times 1}{10} = 6.000$$

Example 2: A flow sensor produces 400 pulses per gallon. Display flow rate in tenths of gallons per hour.

$$RS = \frac{3600 \times 10}{400} = 90.00$$

Programming Rate Scale Factor

The third program mode screen allows you to enter the rate scale factor.

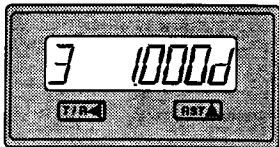

The lower case "d" appears on the right of the display when it is time to enter the decimal point position for the rate scaler.

Note: This decimal point is used for the rate scaler only and will not appear on the ratemeter screen.

Press the **RST** key to change the first digit to the correct value. Press the **T/R** key to select the next digit to be changed. Repeat this process until all the digits are correct. When the "d" appears, press the **RST** key until the decimal point is in the desired location.

Ratemeter Decimal Point

The fourth program mode screen is used to enter the decimal point position for the ratemeter run-mode display.

The display will show the screen number (4) and four zero's.

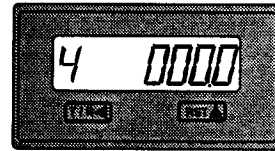

Press the **RST** key until the decimal point is in the correct position.

Rate x1 or x10

The fifth screen is used to select the rate display multiplier of one or ten. Selecting rate x10 will add a zero to the far right of the display. This zero will not change value and does not affect the decimal point position.

The display will show the screen number (5) and a 1 at the right.

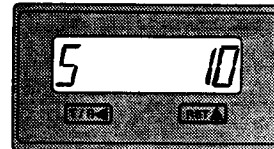

Press the **RST** key to select 1 or 10.

Front Reset Key Enable/Disable

The last screen in the program mode is used to determine whether the front panel reset key will function. The screen will show a number 6 on the left and an R on the right.

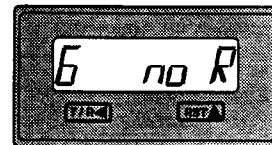

Press the **RST** key to choose the option you want.

Note: The reset terminal on the rear panel is still active when the front reset button is disabled.

Note: To exit the program mode, disconnect the jumper between terminals 1 and 5.

WIRING RECOMMENDATIONS

Following these suggestions will increase noise immunity and lengthen unit life.

Cable: Make the connection between the count source and the totalizer / ratemeter with a two-conductor shielded cable. Connect the shield to earth ground at one end only.

Relay Coil Suppression: If a relay contact is used as a count source, suppress the relay coil. This can be accomplished with an RC network for AC coils or a diode for DC coils.

Mounting: Do not mount this totalizer / ratemeter near a solenoid or other inductive devices. Supply enough ventilation to keep the totalizer operating within the temperature specifications. Do not mount this unit in a heavy vibration area.

BATTERY SAFETY

The lithium battery that powers your device contains inflammable materials such as lithium organic solvent, and other chemical ingredients. Explosion or fire may result if the battery is not handled correctly. To avoid an accident, follow these guidelines:

- Do not stack or jumble up batteries
- Do not heat batteries above 95°C
- Do not disassemble batteries
- Do not recharge lithium batteries
- Do not apply pressure to, or deform batteries
- Do not solder to batteries
- Do not dispose of batteries in fire
- Insert battery with correct polarity

Terminal	Function	Operation
1	Ground	
2	Input B Count Input	Use with Contact Closure to Ground up to 20 Hz Count Speed
3	Input A Count Input	Use with Current Sourcing up to 10 kHz Count Speed
4	Reset	Connect to Ground to Reset Totalizer. This is a maintained or Level Sensitive Reset
5	Program Enable	Connect to Ground to Enter Program Mode

WIRING DIAGRAMS

CONTACT CLOSURE COUNT INPUT

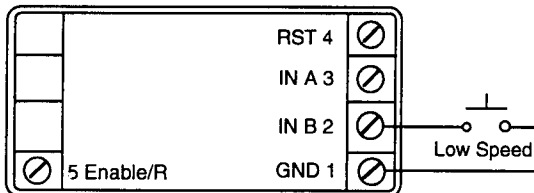

SOLID STATE COUNT / RATE INPUT MAGNETIC PICKUP

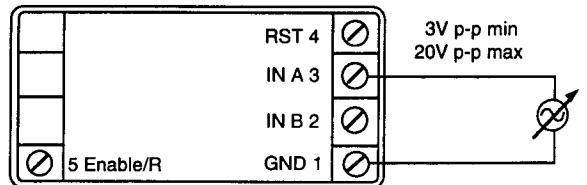

* Not suitable for direct turbine meter or direct self-generating paddlewheel input.

SOLID STATE COUNT / RATE INPUT CURRENT SOURCING SENSOR

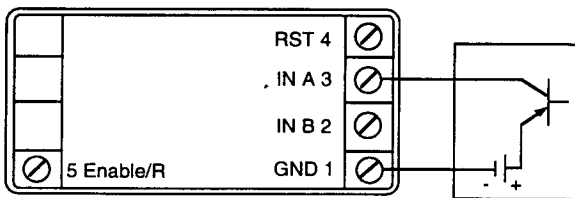

PROGRAM MODE ENABLE

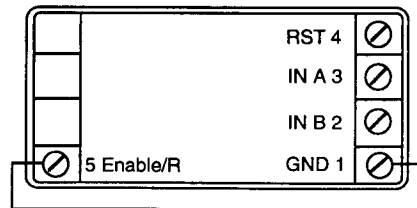

SOLID STATE COUNT / RATE INPUT CURRENT SINKING SENSOR

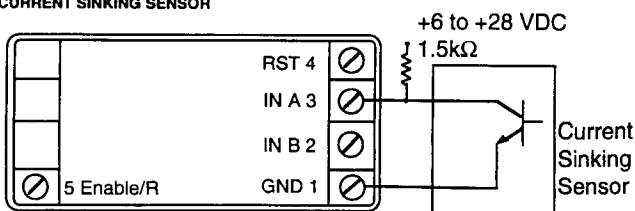

REMOTE RESET

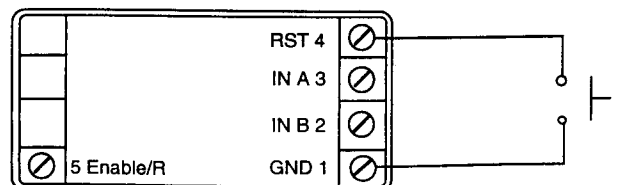

REPLACEMENT PARTS

DPC10-BAT	Battery
46066-210	Gasket
53300-241	Mounting Clip
28772-200	Mounting Screw

OTHER OMEGA MINI COUNTER PRODUCTS

DPC10-TL	Totalizer
DPC10-CS	Add/Subtract Totalizer (Solid State Input)
DPC10-CC	Add/Subtract Totalizer (Contact Input)
DPC10-QT	Quadrature Indicator
DPC10-RM	Ratemeter



WARRANTY

OMEGA warrants this unit to be free of defects in materials and workmanship and to give satisfactory service for a period of **13 months** from date of purchase. OMEGA Warranty adds an additional one (1) month grace period to the normal **one (1) year product warranty** to cover handling and shipping time. This ensures that our customers receive maximum coverage on each product. If the unit should malfunction, it must be returned to the factory for evaluation. Our Customer Service Department will issue an Authorized Return (AR) number immediately upon phone or written request. Upon examination by OMEGA, if the unit is found to be defective it will be repaired or replaced at no charge. However, this WARRANTY is VOID if the unit shows evidence of having been tampered with or shows evidence of being damaged as a result of excessive corrosion; or current, heat, moisture or vibration; improper specification; misapplication; misuse or other operating conditions outside of OMEGA's control. Components which wear or which are damaged by misuse are not warranted. These include contact points, fuses, and triacs.

We are glad to offer suggestions on the use of our various products. Nevertheless OMEGA only warrants that the parts manufactured by it will be as specified and free of defects.

OMEGA MAKES NO OTHER WARRANTIES OR REPRESENTATIONS OF ANY KIND WHATSOEVER, EXPRESSED OR IMPLIED, EXCEPT THAT OF TITLE AND ALL IMPLIED WARRANTIES INCLUDING ANY WARRANTY OF MERCHANTABILITY AND FITNESS FOR A PARTICULAR PURPOSE ARE HEREBY DISCLAIMED.

LIMITATION OF LIABILITY: The remedies of buyer set forth herein are exclusive and the total liability of OMEGA with respect to this order, whether based on contract, warranty, negligence, indemnification, strict liability or otherwise, shall not exceed the purchase price of the component upon which liability is based. In no event shall OMEGA be liable for consequential, incidental or special damages.

Every precaution for accuracy has been taken in the preparation of this manual, however, OMEGA ENGINEERING, INC. neither assumes responsibility for any omissions or errors that may appear nor assumes liability for any damages that result from the use of the products in accordance with the information contained in the manual.

RETURN REQUESTS / INQUIRIES

Direct all warranty and repair requests/inquiries to the OMEGA ENGINEERING Customer Service Department. Call toll free in the USA and Canada: 1-800-622-2378, FAX: 203-359-7811; International: 203-359-1660, FAX: 203-359-7807.

BEFORE RETURNING ANY PRODUCT(S) TO OMEGA, YOU MUST OBTAIN AN AUTHORIZED RETURN (AR) NUMBER FROM OUR CUSTOMER SERVICE DEPARTMENT (IN ORDER TO AVOID PROCESSING DELAYS). The assigned AR number should then be marked on the outside of the return package and on any correspondence. Please have the following information available BEFORE contacting OMEGA:

1. P.O. number under which the product was PURCHASED,
2. Model and serial number of the product, and
3. Repair instructions and/or specific problems you are having with the product.

OMEGA's policy is to make running changes, not model changes, whenever an improvement is possible. That way our customers get the latest in technology and engineering.

OMEGA is a registered trademark of OMEGA ENGINEERING, INC.

© Copyright 1993 OMEGA ENGINEERING, INC. All rights reserved including illustrations. Nothing in this manual may be reproduced in any manner, either wholly or in part for any purpose whatsoever without written permission from OMEGA ENGINEERING, INC. Printed in U.S.A.



One Omega Drive, P.O. Box 4047
Stamford, CT 06907
Tel: (203) 359-1660
Telex: 996404 Cable OMEGA
Fax: (203) 359-7700