

**RoHS 2 Compliant**

**506**  
**VOLT-INPUT 4/20 mA**  
**TWO-WIRE TRANSMITTER**

**10647ML-01**

© Copyright 1997, NEWPORT Electronics, Inc. All rights reserved.

This documentation may not be copied, photocopied, reproduced, translated, or reduced to any electronic medium or machine-readable form, in whole or in part, without prior written consent of NEWPORT Electronics, Inc.

# SAFETY CONSIDERATIONS



This device is marked with the international Caution symbol. It is important to read this manual before installing or commissioning this device as it contains important information relating to Safety and EMC (Electromagnetic Compatibility).

## Unpacking & Inspection



Unpack the instrument and inspect for obvious shipping damage. Do not attempt to operate the unit if damage is found.

This instrument is a panel mount device protected in accordance with Class I of EN 61010 (115/230 AC power connections). Installation of this instrument should be done by Qualified personnel. In order to ensure safe operation, the following instructions should be followed.

This instrument has no power-on switch. An external switch or circuit-breaker shall be included in the building installation as a disconnecting device. It shall be marked to indicate this function, and it shall be in close proximity to the equipment within easy reach of the operator. The switch or circuit-breaker shall not interrupt the Protective Conductor (Earth wire), and it shall meet the relevant requirements of IEC 947-1 and IEC 947-3 (International Electrotechnical Commission). The switch shall not be incorporated in the mains supply cord.

Furthermore, to provide protection against excessive energy being drawn from the mains supply in case of a fault in the equipment, an overcurrent protection device shall be installed.



- The **Protective Conductor** must be connected for safety reasons. Check that the power cable has the proper Earth wire, and it is properly connected. It is not safe to operate this unit without the Protective Conductor Terminal connected.



- Do not exceed voltage rating on the label located on the top of the instrument housing.
- Always disconnect power before changing signal and power connections.
- Do not use this instrument on a work bench without its case for safety reasons.
- Do not operate this instrument in flammable or explosive atmospheres.
- Do not expose this instrument to rain or moisture.

## EMC Considerations

- Whenever EMC is an issue, always use shielded cables.
- Never run signal and power wires in the same conduit.
- Use signal wire connections with twisted-pair cables.
- Install Ferrite Bead(s) on signal wires close to the instrument if EMC problems persist.

CHG	ECO NO	DATE	BY	CHK
C	9236	03 NOV 97	ML	

<b>MODEL 506</b> <b>VOLT-INPUT 4/20 mA TWO-WIRE TRANSMITTER</b>
--

**OWNERS' MANUAL**

**TABLE OF CONTENTS**

**MAIN ASSEMBLY 506**

Safety Instructions .....	i
1.0 General Information .....	1
2.0 Specifications .....	2
3.0 Mechanical Assembly and Installation .....	3
4.0 Power and Signal Input Connections .....	8
5.0 Configuration .....	9
6.0 Drawings .....	14

**ILLUSTRATIONS**

Figure 3-1 Exploded View of Model 506 .....	4
Figure 3-2 Bulkhead and Track Mounting .....	5
Figure 3-3 DIN Track Mounting .....	6
Figure 3-4 Spring Retainer for Explosion-Proof Housing .....	7
Figure 4-1 Power Input Connections .....	8
Figure 5-1 Calibration Hookup .....	9
Figure 5-2 Jumper Diagram .....	10
Figure 5-3 Calibration Flowchart .....	13
Figure 6-1 506 Case Dimensions .....	14
Figure 6-2 506 Preamp Block Diagram .....	15
Figure 6-3 506 Postamp Block Diagram .....	15
Table 5-1 506-1 Input Ranges in Volts Obtained with Jumpers .....	11
Table 5-2 506-2 Input Ranges in Volts Obtained with Jumpers .....	12

**APPENDICES**

Appendix A Transmitter Accuracy Factors .....	16
---	----

## 1.0 GENERAL INFORMATION

The 506 two-wire transmitter takes in voltage signals, provides amplification, common-mode isolation, and controls the current drawn from a 9-to-50 V dc source to produce the 4-to-20 milliampere output signal.

Model 506 is ordered with a low-voltage input range, designated as 506-1, or with a high-voltage input range, designated as 506-2. The components of the two models are graded and matched to meet stringent specifications; 506-1 and 506-2 are not interchangeable. No field conversion can be performed without performance degradation.

Common-mode voltage between the input and the output circuits is tested at 1500 V rms. As much as 750 ohms dropping resistance may be used in the power leads of the 506 when the unit is energized from a 24 V dc source because of the small compliance voltage needed by the unit. Accidental overloads of over one minute by 120 V rms on either input or output leads do not damage the 506.

### 1.1 ACCURACY AND STABILITY

The 506 uses matched-tempco input resistor bridges. Selected resistors in a temperature-sensing output bridge provide cancellation of both input and output Span temperature effects. High-ambient-temperature compensation points are checked. The unit is certified for accuracy from -40 to +85°C (-40 to +185°F).

### 1.2 ADAPTABILITY/TURNDOWN

The Span of the 506 can be ranged anywhere from .5 V to 50 V by selection of one of four jumper positions, with fine tuning provided by a multiturn, top-accessible potentiometer. Sixteen Zero steps, also provided by jumpers, allow placement of the input for 4-mA output anywhere from -35 V to +50 V, with fine tuning provided by another top-accessible, multiturn potentiometer. This turndown capability exceeds that of any other known transmitter.

### 1.3 WIRING ISOLATION

Input (and shield) and output (DC power) barrier strips accept wires up to two mm in diameter (13 gauge), and are mechanically isolated from each other to prevent input/output wiring contact during installation.

### 1.4 SHOCK RESISTANCE

Lightweight circuit boards are formed into a rigid box structure and firmly soldered and epoxied to the case top. The circuit-board box is doubly coated with RTV silicone for environmental protection. When installed in the rugged, die-cast case, the 506 can withstand the shock of a 6-foot drop onto a hard surface (although scarring of the case and/or deformation of the plastic cover can occur).

### 1.5 WATERPROOF/RFI-RESISTANT CASE

The Model 506 case is made from Zamac (zinc alloy), coated with polyurethane, and gasketed with fluorosilicone. Fluorosilicone plugs protect the top-access Span and Zero potentiometers.

### 1.6 MOUNTING ADAPTABILITY

The small size of the instrument (less than 75 mm or 3 in OD) permits mounting in many small spaces, including explosion-proof housings for wiring compatibility with other equipment in hazardous environments. A bulkhead adaptor provides for wall-mounting. A snaptrack adaptor mounts on either American or European relay tracks. Tapped holes in the case rear provide for custom mounting on any surface, indoor or out. An optional opaque top cover shields the barrier strips from exposed environments.

## 2.0 SPECIFICATIONS

### 2.1 INPUT

Configuration: Isolated input, volts in, mA out

Input impedance: 1.0 M $\Omega$

Common mode voltage, input to case: Test, 2100 V peak; IEC spacing for over 354 V peak

Common mode rejection, input to case: 100 dB min at 60 Hz

Overvoltage protection: 120 V ac max/1 min exposure

#### 2.1.1 506-1 Voltage Ranges

Span (for output of 16 mA change): .5 to 5 V

Zero (for 4 mA output): -3.5 to 6.0 V

#### 2.1.2 506-2 Voltage Ranges

Span (for output of 16 mA change): 5 to 50 V

Zero (for 4 mA output): -35 to 60 V

### 2.2 OUTPUT

Linear range: 4 mA to 20 mA dc

Compliance (supply-voltage): 9 to 50 V dc

Overvoltage protection: 120 V ac

Reverse polarity protection: 400 V peak

Common mode voltage, output to case: 1500 V ac max

Common mode rejection, output to case: 100 dB min at 60 Hz

### 2.3 ACCURACY

Hysteresis and repeatability: Within  $\pm 5$  mV,  $\pm 0.1\%$  of Span

Six-month stability: Within  $\pm 5$  mV  $\pm 0.2\%$  of base input

Power supply effect: Within  $\pm 0.005\%/V$

Ambient temperature effect for 50°C change: Zero and conformity: Within  $\pm 10$  mV

Span: Within 0.3%

Suppression:  $\pm 0.2\%$  of base input

### 2.4 ENVIRONMENTAL

Operating temperature: -40 to 85°C

Storage temperature: -55 to 125°C

Humidity: To 100%

Vibration: 1.52 mm (.06 in) double amplitude, 10-80 Hz cycled

Shock: 55g, half-sine, 9-13 msec duration, 6' drop to hard surface

Watertight pressure limit: 35 kPa (5 PSI)

Mounting position: Any

### 2.5 MECHANICAL

Case material: Zamac (zinc alloy), polyurethane-coated, fluorosilicone-gasketed

Weight: 300 g (10 oz)

Diameter: 74 mm (2.9 in)

Height (including barriers): 52 mm (2.1 in)

Connections: #6 screws with wire clamps

### 3.0 MECHANICAL ASSEMBLY AND INSTALLATION

#### 3.1 UNPACKING AND INSPECTION

Your 506 transmitter was systematically inspected and tested, then carefully packed before shipment. Unpack the instrument and inspect for shipping damage. If possible, remove the casing and visually inspect the internal circuitry. Notify the freight carrier immediately if damage exists.

Each package includes an assembled transmitter and an owners' manual. If these items are not according to your order, contact your local distributor or Newport Electronics.

#### 3.2 SAFETY CONSIDERATIONS

As delivered from the factory/distributor, this instrument complies with required safety regulations. To prevent fire or electrical hazard and to ensure safe operation, please follow the guidelines below.

**VISUAL INSPECTION:** Do not attempt to operate the unit if damage is found.

**MOUNTING:** Observe the mounting instructions in Sections 3.3 through 3.6, as applicable. The transmitter must be tightly secured at the time of installation. Case dimensions are provided in Section 6.

**POWER VOLTAGE:** Verify that the instrument is connected for the power voltage rating that will be used (9-50 V dc). If not, make the required changes as indicated in Section 4.

**POWER WIRING** - This instrument has no power-on switch; it will be in operation as soon as the power is connected.

**SIGNAL WIRING** - Do not make signal wiring connections or changes when power is on. Make signal connections before power is applied. If connection changes are required, first disconnect the power.

**EXERCISE CAUTION** - As with any electronic instrument, high voltage may exist when attempting to install, calibrate, or change the push-on jumpers of the transmitter.

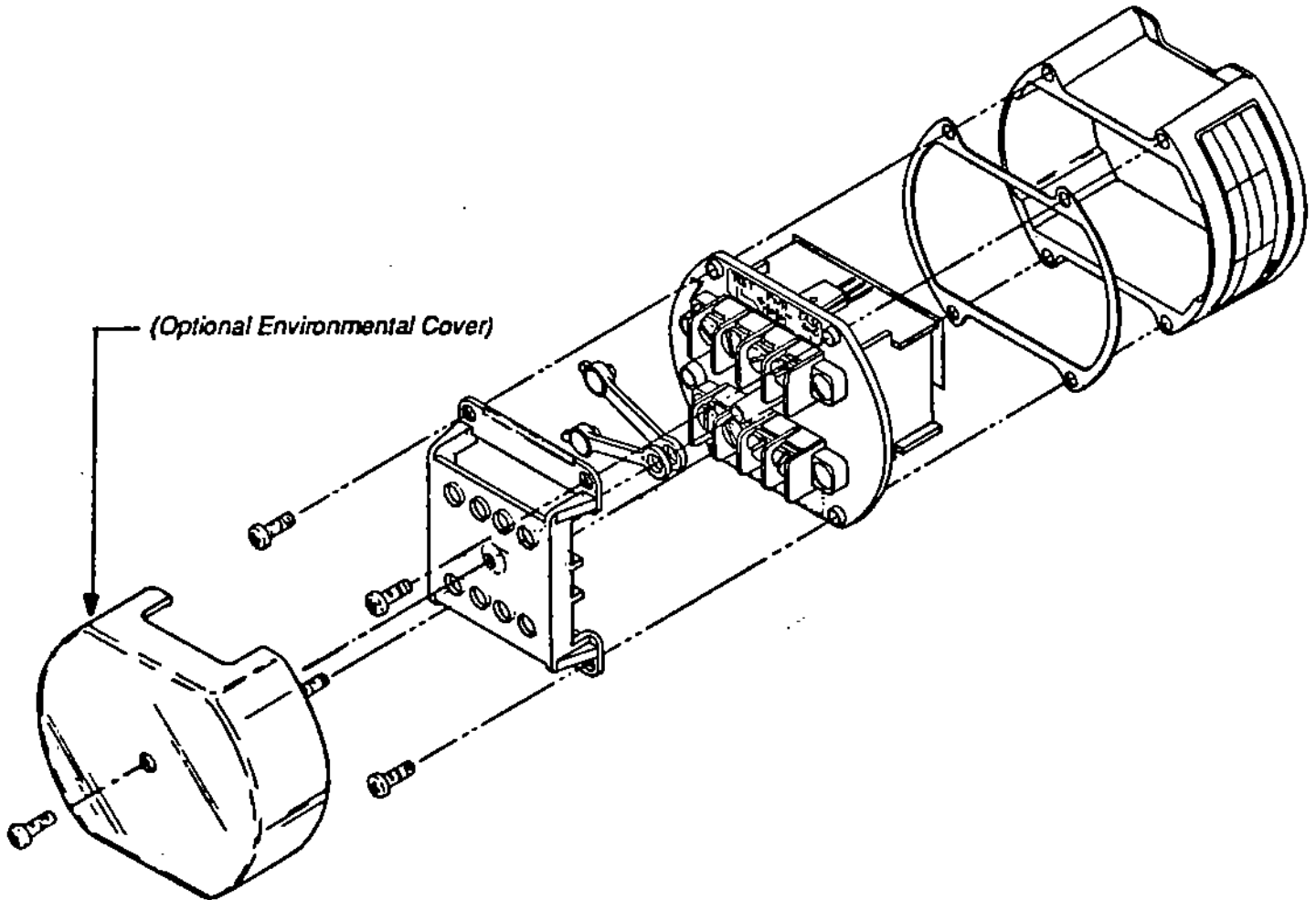

Figure 3-1 Exploded View of Model 506

The low voltage requirement of the 506 enables its use with a current-loop indicator (Newport Model 508 recommended). Tapped holes on the back of the case provide for custom mounting to a flat surface; flanges on the back of the case provide for standard 8TK2 relay track mounting. For flat surface mounting, use #6 hardware. For 8TK2 relay track mounting, simply push onto track.

### 3.3 OPTIONAL ADAPTERS FOR MOUNTING

The following optional adaptors provide various mounting choices:

- a. Adaptor plate for either front-screw-entry surface mount, or TR2/2TK relay track mount (see Figure 3-2).
- b. Rail clamp for DIN-EN-50 022 relay track mount (Figure 3-3).
- c. Spring retainers for external 76.4 to 88.9 mm (3 to 3.5 in) explosion-proof housing mount (see Figure 3-4).

### 3.4 SURFACE AND TR2/2TK RELAY TRACK MOUNTING PROCEDURE

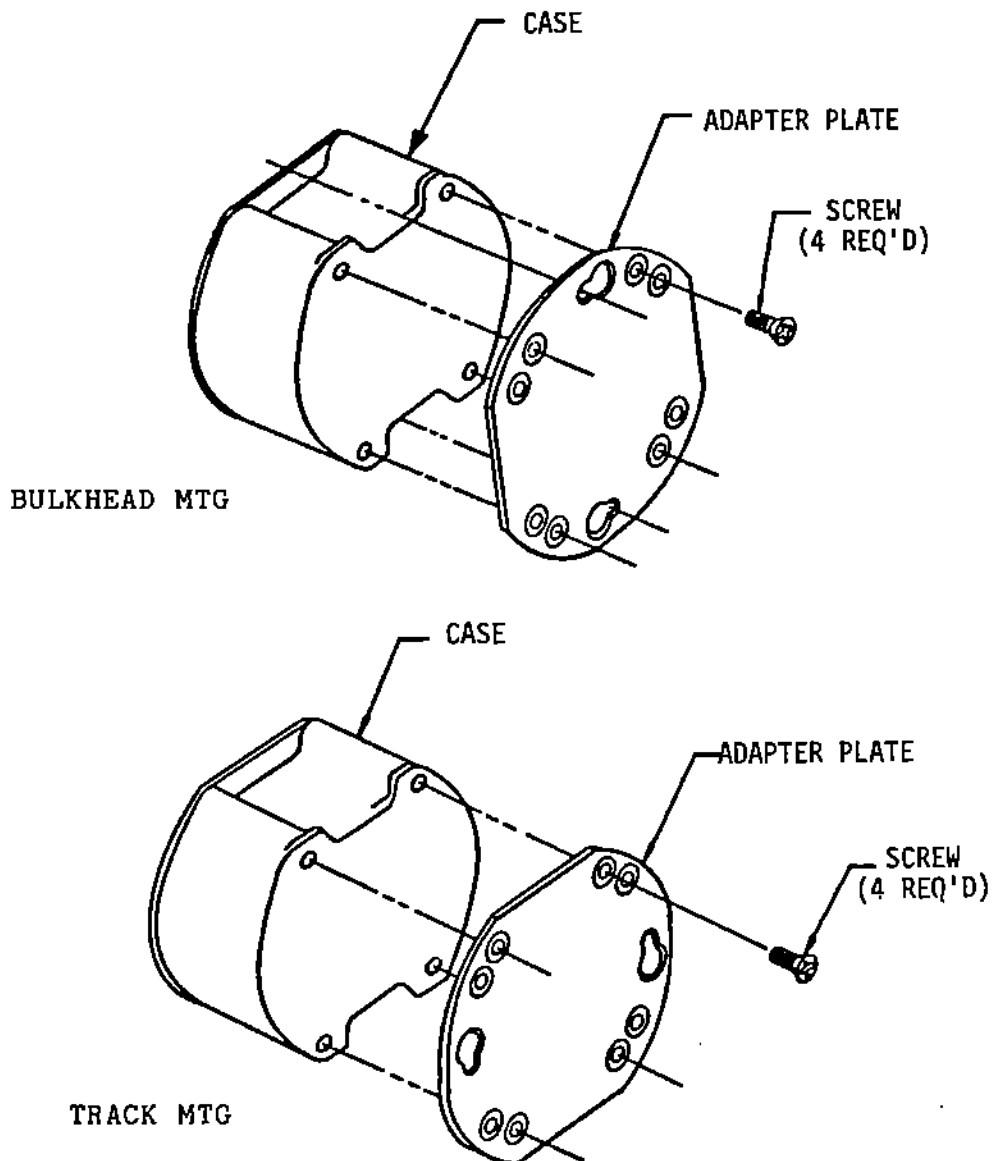
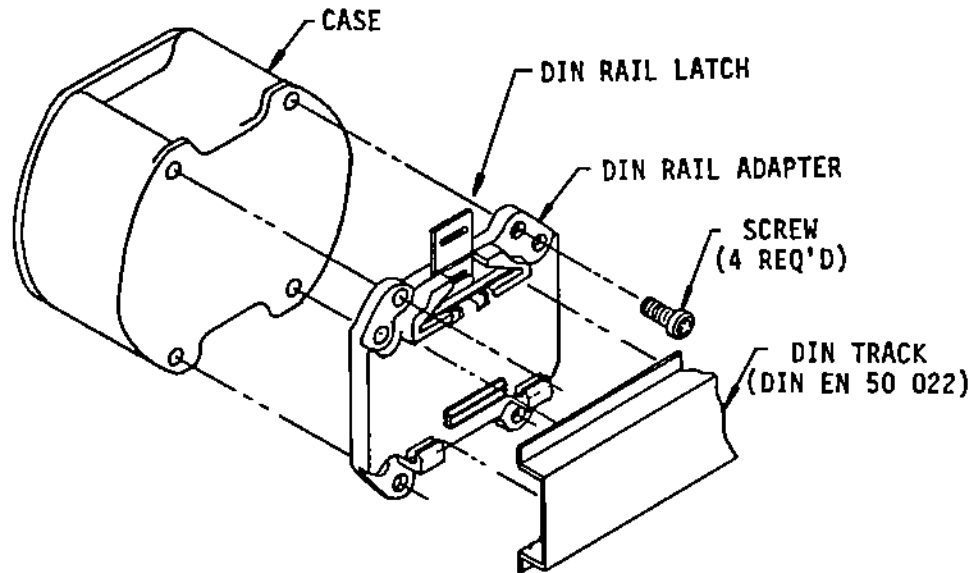

Figure 3-2 Bulkhead and Track Mounting

1. Position plate for desired application.
2. Use #6 hardware to mount plate to back of 506 case.



### 3.5 DIN EN 50 022 RELAY TRACK MOUNTING PROCEDURE



DIN TRACK MTG: SHOWN FOR HORIZONTAL TRACK

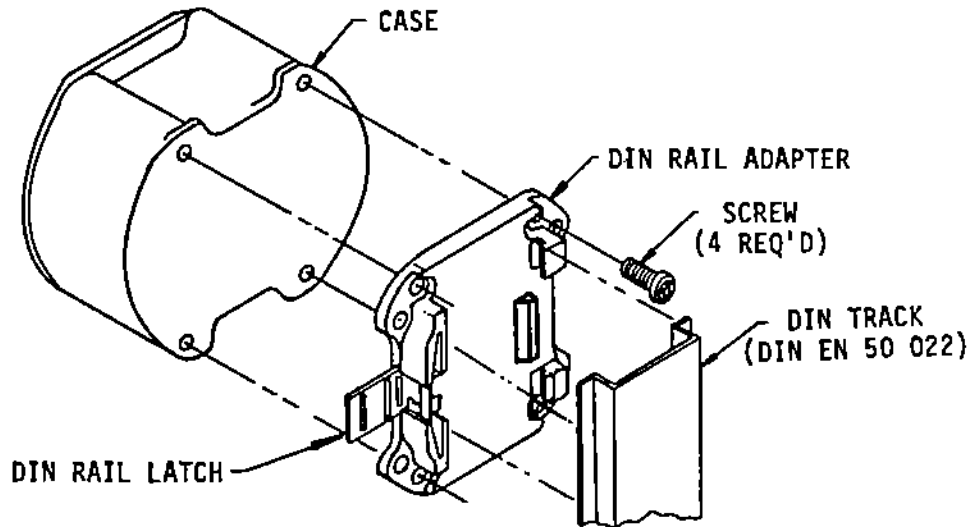

DIN TRACK MTG: SHOWN FOR VERTICAL TRACK

Figure 3-3 DIN Track Mounting

1. Position plate for desired track direction.
2. Use #8 flathead screws to mount plate to back of 506 case.
3. Snap 506 case assembly onto DIN rail.

### 3.6 EXTERNAL EXPLOSION-PROOF HOUSING MOUNTING

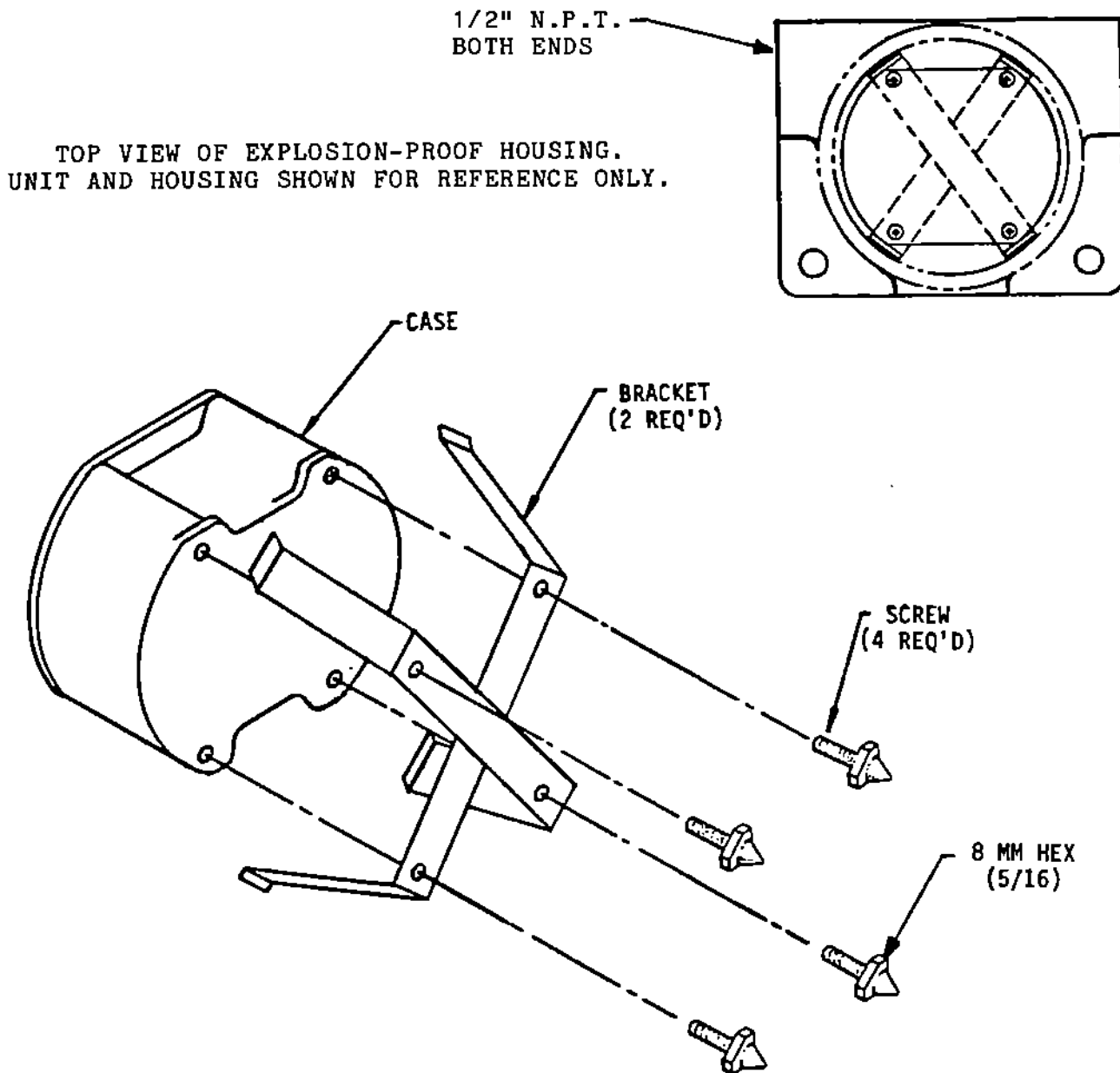

Figure 3-4 Spring Retainer for Explosion-Proof Housing

1. Position spring retainer across back of 506 case.
2. Use wire protector feet (4 provided with above option) to hold spring retainers in place.
3. Press 506 case assembly into explosion-proof housing.

## 4.0 POWER AND SIGNAL INPUT CONNECTIONS

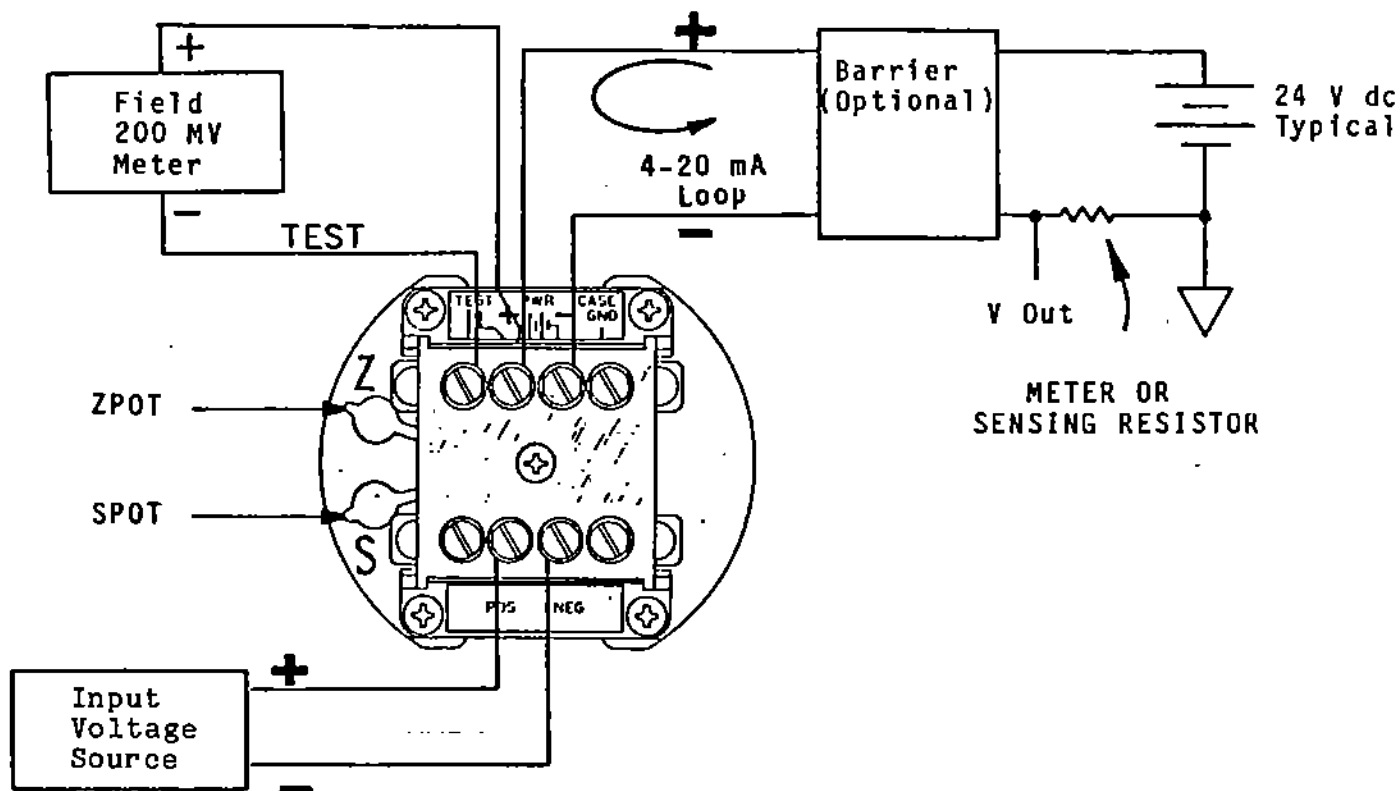

Figure 4-1 Power Input Connections

### 4.1 GENERAL

TEST, PWR +, and PWR - screws accept 2 mm (13 gauge) or lighter wire. CASE GND is grounded to the case. Input range is 9-50 V dc.

#### SCREW-TERMINAL PIN ASSIGNMENT

1	TEST
2	+ POWER/OUTPUT
3	- POWER/OUTPUT
4	CASE GND
A	N/C
B	+ VOLTAGE/INPUT
C	- VOLTAGE/INPUT
D	N/C

## 5.0 CONFIGURATION

Model 506-1 is normally delivered configured for 0/5 V = 4/20 mA;  
Model 506-2 is normally delivered configured for 0/50 V = 4/20 mA.

## 5.1 TOOLS AND EQUIPMENT

#1 Phillips screwdriver  
3/32" flat blade screwdriver, VACO 17764 or equivalent  
Two 4 1/2 digit DVMs (digital voltmeters)  
10 or 100 ohm 1% resistor  
Fixed or variable DC power supply or battery (range of 11-30 V dc)  
Voltage source, -50 to +100 V

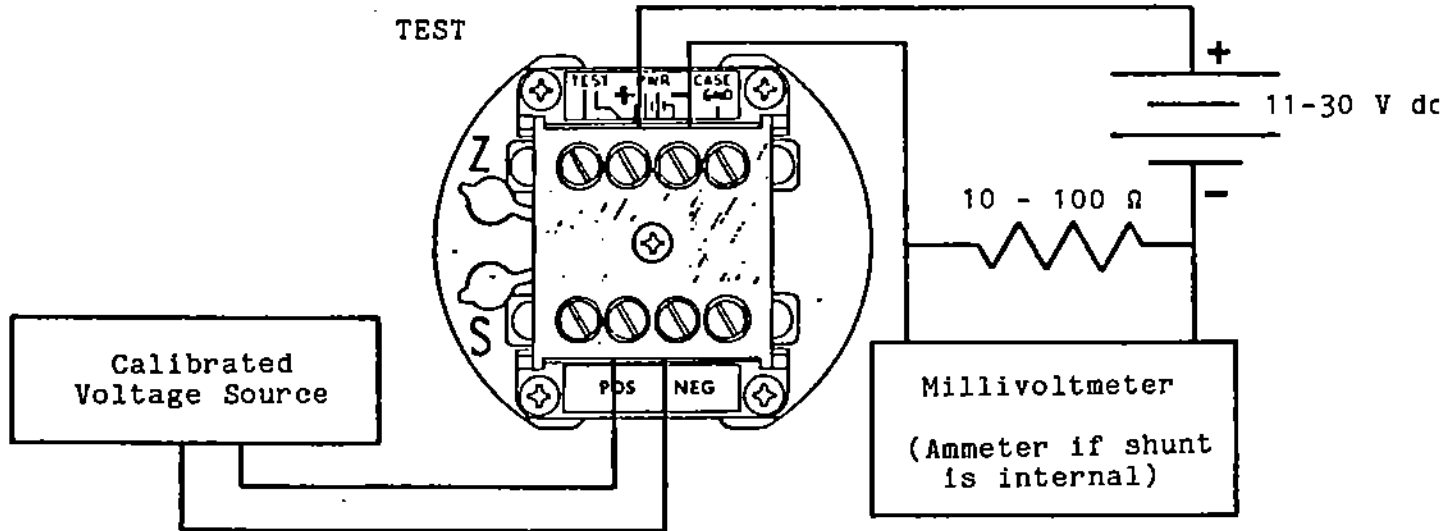

Figure 5-1 Calibration Hookup

## 5.2 CALIBRATION PROCEDURE

Refer to Figure 5-3 (Calibration flowchart) and familiarize yourself with the general procedure to be followed.

1. Remove the four Phillips-head screws from the case top and set aside the plastic barrier.
2. Lift out the electronics assembly attached to the case lid.
3. Setting aside the case and sealing gasket, pull out the two sealing plugs which cover the Span and Zero potentiometers (SPOT). Adjust SPOT five turns clockwise (CW) from the full counter-clockwise (CCW) position (SPOT and ZPOT are both multi-turn pots).

NOTE: SPOT is never used more than 3/4 of the way clockwise, since full clockwise disconnects the feedback.

4. Refer to Table 5-2 and select the range which comes closest to your desired Base and Top voltage levels. Having done this, note which zero and span jumpers are called out by the table for the range that you have selected.
5. Turn the transmitter so that the jumper pin-forest is at hand, and move the push-on jumpers to the positions indicated in Figure 5-2 for the range chosen in the previous step. Place unused jumpers in storage positions.
6. Refer to Figure 5-1 and connect the transmitter to the power supply, voltage source, current shunt, and voltmeter.
7. Using Table 5-1, determine LO-IN, the Base voltage level.
8. Determine HI-IN, the Top voltage level.
9. Set the voltage calibration source to LO-IN and adjust ZPOT for 4.00 mA output current.
10. Set the voltage calibration source to HI-IN volts and note the output current (generally this will not be 20 mA). This current level is designated INITIAL TOP (IT).

11. Calculate TOP CORRECT (TC), the corrected output current, with the following equation (generally this will also not equal 20 mA).

$$TC = 16 \cdot IT / (IT - 4)$$

12. Adjust SPOT to obtain TOP CORRECT milliamperes output current.
13. Now readjust ZPOT so that the output reads 20.00 mA.
14. Set the voltage calibration source to LO-IN volts. If the output current is not 4.00 mA, repeat steps 9 through 14.
15. When calibration is complete, remove the 506 from the calibration setup, replace the pot sealing plugs, and install the unit in the case insuring that the four screws are tightened enough to compress but not flatten the gasket.

EXAMPLE: (For the 506-2)

Input Range = -10.00 to +30.00 V  
 LO Input = -10.00 V  
 HI Input = +30.00 V  
 Span and Z Jumpers - See Table 5-2

- Calibrate:
1. Set SPOT to about 3/4 CCW.
  2. Set voltage source to -10.00 V.
  3. Adjust ZPOT to 4.00 mA.
  4. Set voltage source to +30.00 V.
  5. Read current, designated Initial Top (IT).
  6. Calculate  $TC = 16 \cdot IT / (IT - 4)$  mA.
  7. Adjust SPOT to obtain Top Correct (TC) current.
  8. Adjust ZPOT to obtain 20 mA current.
  9. Set voltage source to -10.00 V.
  10. If the output is not 4.00 mA, retrim starting at Item 3 above.

### 5.3 PIN ASSIGNMENTS (Jumper Pin-forest P1)

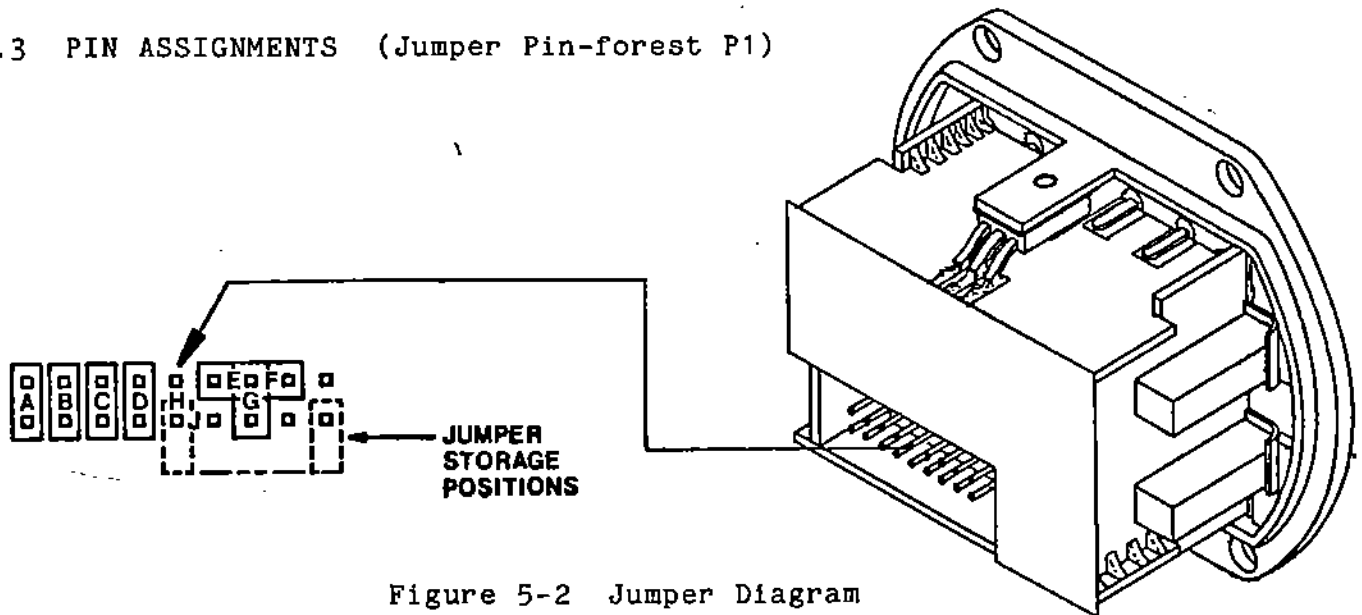

Figure 5-2 Jumper Diagram

Pin	Function	Pin	Function
P1-1	"A" Zero Jumper	P1-10	Input tempco control
P1-2		P1-11	V ref input
P1-3	"B"	P1-12	"E" Span jumper point
P1-4		P1-13	"G" Span jumper point
P1-5	"C"	P1-14	Span jumper common ground
P1-6		P1-15	Zero pot wiper (Input high)
P1-7	"D"	P1-16	"F" Span jumper point
P1-8		P1-17	Input low
P1-9	Preamp divider center	P1-18	Preamp regulated supply voltage

## MODEL 506-1

WITHOUT USING SPAN JUMPERS			USING SPAN JUMPER 'E'		
Z JUMPERS Adjustable Range (Volts)			Z JUMPERS Adjustable Range (Volts)		
	Base	Top		Base	Top
NONE	-3.5	1.5 to 5.5	NONE	-3.5	-2.0 to 1.0
C (ONLY)	-2.5	4.0 to 6.5	D (ONLY)	-3.5	-2.0 to 1.5
C AND D	-2.5	4.5 to 7.5	C (ONLY)	-3.0	-1.5 to 2.0
B (ONLY)	-2.0	5.0 to 8.0	C AND D	-2.5	-1.0 to 2.5
B AND D	-1.5	5.5 to 8.5	B (ONLY)	-2.0	-.5 to 3.0
B AND C	-1.0	6.0 to 9.0	B AND D	-1.5	0 to 3.5
B,C AND D	-.5	6.5 to 9.5	B AND C	-1.0	.5 to 4.0
A (ONLY)	0	7.0 to 10.0	B,C AND D	-.5	1.0 to 4.5
A AND D	.5	7.5 to 10.5	A (ONLY)	0	1.5 to 5.0
A AND C	1.0	8.0 to 11.0	A AND D	.5	2.0 to 5.5
A,C AND D	1.5	8.5 to 11.0	A AND C	1.0	2.5 to 6.0
A AND B	2.5	9.0 to 12.0	A,C AND D	1.5	3.0 to 6.5
A,B AND D	3.5	9.5 to 13.0	A AND B	2.5	4.0 to 7.5
A,B AND C	4.5	10.0 to 14.0	A,B AND D	3.5	5.0 to 8.5
A,B,C AND D	6.0	10.5 to 16.0	A,B AND C	4.5	6.0 to 9.5
			A,B,C AND D	6.0	7.5 to 11.0

USING SPAN JUMPER 'F'			USING SPAN JUMPER 'G'		
Z JUMPERS Adjustable Range (Volts)			Z JUMPERS Adjustable Range (Volts)		
	Base	Top		Base	Top
NONE	-3.5	-2.5 to -1.0	NONE	-3.5	-3.0 to -2.5
D (ONLY)	-3.5	-2.5 to -.5	D (ONLY)	-3.5	-3.0 to -2.0
C (ONLY)	-3.0	-2.0 to 0	C (ONLY)	-3.0	-2.5 to -1.5
C AND D	-2.5	-1.5 to .5	C AND D	-2.5	-2.0 to -1.0
B (ONLY)	-2.0	-1.0 to 1.0	B (ONLY)	-2.0	-1.5 to -.5
B AND D	-1.5	-.5 to 1.5	B AND D	-1.5	-1.0 to 0
B AND C	-1.0	0 to 2.0	B AND C	-1.0	-.5 to .5
B,C AND D	-.5	.5 to 2.5	B,C AND D	-.5	0 to 1.0
A (ONLY)	0	1.0 to 3.0	A (ONLY)	0	.5 to 1.5
A AND D	.5	1.5 to 3.5	A AND D	.5	1.0 to 2.0
A AND C	1.0	2.0 to 4.0	A AND C	1.0	1.5 to 2.5
A,C AND D	1.5	2.5 to 4.5	A,C AND D	2.0	2.5 to 3.5
A AND B	2.0	3.0 to 5.0	A AND B	3.0	3.5 to 4.5
A,B AND D	3.0	4.0 to 6.0	A,B AND D	4.0	4.5 to 5.5
A,B AND C	4.5	5.5 to 7.5	A,B AND C	5.0	5.5 to 6.5
A,B,C AND D	6.0	7.0 to 9.0	A,B,C AND D	6.0	6.5 to 7.5

Table 5-1 506-1 Input Ranges In Volts Obtained With Jumpers

MODEL 506-2

USING SPAN JUMPER 'E'			USING SPAN JUMPER 'F'		
Z JUMPERS Adjustable Range (Volts)			Z JUMPERS Adjustable Range (Volts)		
	Base	Top		Base	Top
NONE	-35	-20 to 10	NONE	-35	-25 to -10
D (ONLY)	-35	-20 to 15	D (ONLY)	-35	-25 to -5
C (ONLY)	-30	-15 to 20	C (ONLY)	-30	-20 to 0
C AND D	-25	-10 to 25	C AND D	-25	-15 to 5
B (ONLY)	-20	-5 to 30	B (ONLY)	-20	-10 to 10
B AND D	-15	0 to 35	B AND D	-15	-5 to 15
B AND C	-10	5 to 40	B AND C	-10	0 to 20
B,C AND D	-5	10 to 45	B,C AND D	-5	5 to 25
A (ONLY)	0	15 to 50	A (ONLY)	0	10 to 30
A AND D	5	20 to 55	A AND D	5	15 to 35
A AND C	10	25 to 60	A AND C	10	20 to 40
A,C AND D	15	30 to 65	A,C AND D	15	25 to 45
A AND B	25	40 to 75	A AND B	20	30 to 50
A,B AND D	35	50 to 85	A,B AND D	30	40 to 60
A,B AND C	45	60 to 95	A,B AND C	45	55 to 75
A,B,C AND D	60	75 to 110	A,B,C AND D	60	70 to 90

USING SPAN JUMPER 'G'		
Z JUMPERS Adjustable Range (Volts)		
	Base	Top
NONE	-35	-30 to -25
D (ONLY)	-35	-30 to -20
C (ONLY)	-30	-25 to -15
C AND D	-25	-20 to -10
B (ONLY)	-20	-15 to -5
B AND D	-15	-10 to 0
B AND C	-10	-5 to 5
B,C AND D	-5	0 to 10
A (ONLY)	0	5 to 15
A AND D	5	10 to 20
A AND C	10	15 to 25
A,C AND D	20	25 to 35
A AND B	30	35 to 45
A,B AND D	40	45 to 50
A,B AND C	50	55 to 65
A,B,C AND D	60	65 to 75

Table 5-2 506-2 Input Ranges In Volts Obtained With Jumpers

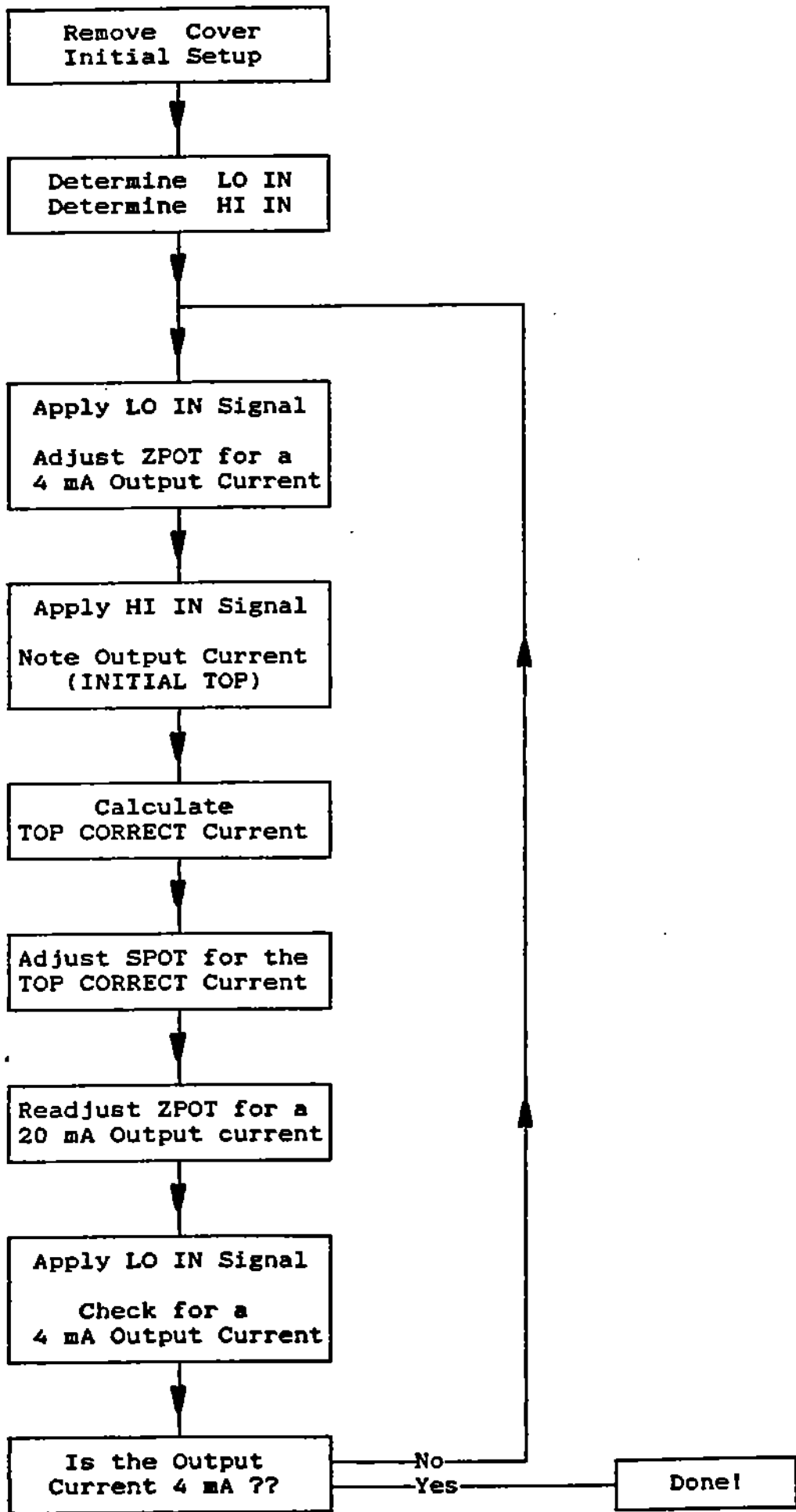

Figure 5-3 Calibration Flowchart



6.0 DRAWINGS

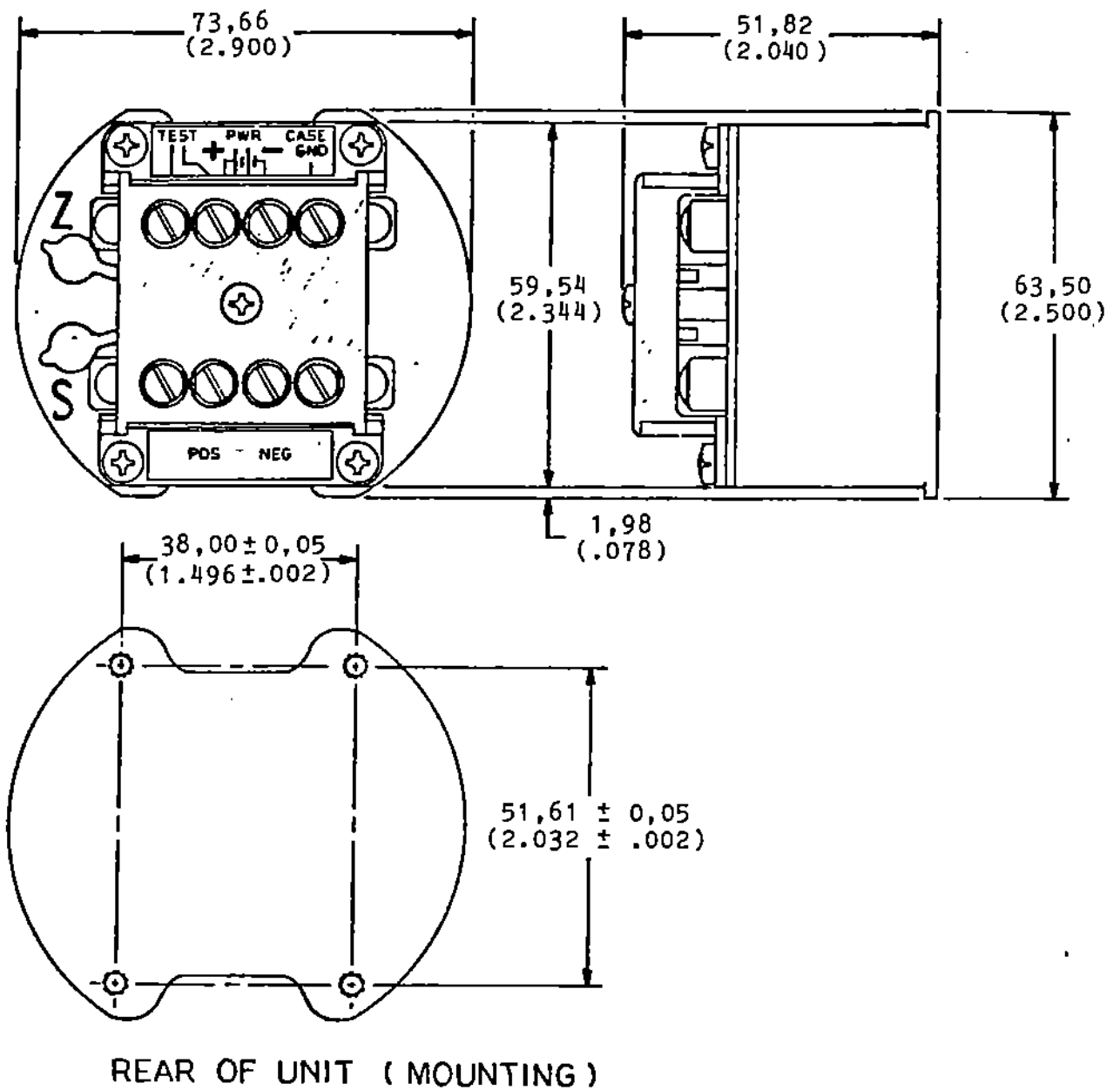

Figure 6-1 506 Case Dimensions

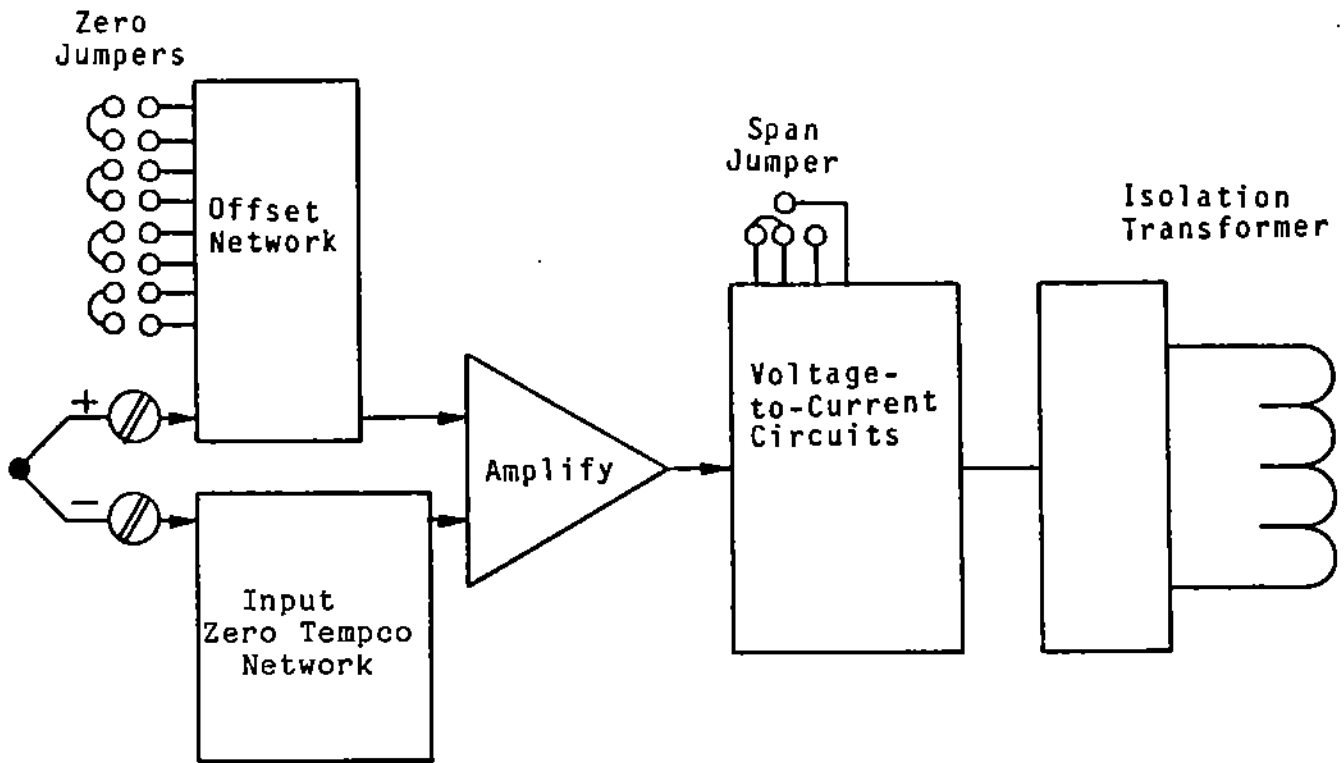

Figure 6-2 506 Preamp Block Diagram

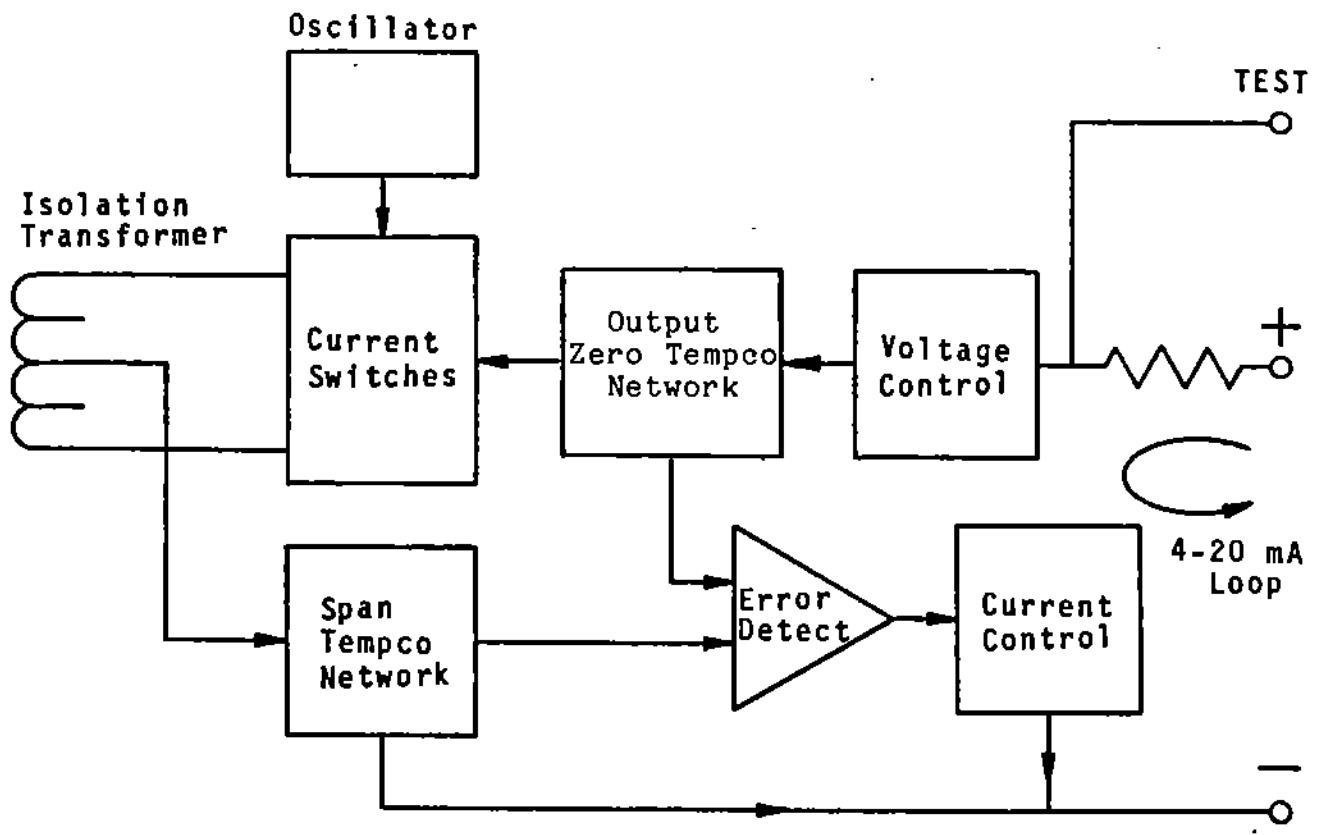

Figure 6-3 506 Postamp Block Diagram

## TRANSMITTER ACCURACY SPECIFICATIONS

The complex current-transmitter circuitry necessary to amplify, isolate, protect, and offset weak input signals while consuming only small amounts of power can distort the signal in many ways. Many transmitter data sheets omit key accuracy factors and/or express performance in percentage values without mentioning the full-scale value. Design limitations can be disguised by such "specsmanship"; the 506 specifications, however, are detailed in order to present the complete performance accuracy.

506 input errors are logically expressed in microvolts, and output errors are readily expressed in microamperes, since output is current. Transmitter users, however, are rarely interested in microamperes. Therefore, these output current errors are translated back to input microvolts as a percentage (or ppm) of the selected Span.

Another fundamental division of errors is that of independence or dependence on Zero and Reading. Resistor aging and tempco mismatch in the Zero and Voltage Reference circuits will produce errors which increase with Zero suppression but which are independent of the amount of Reading (value above the Zero). Resistor aging and tempco mismatch in the amplifier gain (feedback) circuits will usually affect both Zero and Reading accuracy; amplifier gain tempco variations are important to just the Reading stability. A complete error specification needs a term proportional to Zero (suppression) and a term proportional to Reading.

In addition to the Zero and Span tempco (ambient temperature effects), there are other possible errors, often referred to as "hysteresis," "repeatability," "drift," or "time" errors. No statistically-significant errors of these types have yet been observed for the 506, which utilizes a solid-state, band-gap input voltage reference, matched-pair input PNP transistors, integrated-circuit current source and imbalance control, and matched-tempco bridge resistors. The 506 also provides a variable-tempco output adjustment (factory-set) which eliminates many of the errors lumped in this category for other units. Its specification includes a 5 mV tolerance for the calibration accuracies.