

502A-K

THERMOCOUPLE 4-20 mA

TWO-WIRE TRANSMITTER

10633ML-01



This device is marked with the international hazard symbol. It is important to read the Setup Guide before installing or commissioning this device as it contains important information relating to safety and EMC.

It is the policy of NEWPORT to comply with all worldwide safety and EMC/EMI regulations that apply. NEWPORT is constantly pursuing certification of its products to the European New Approach Directives. NEWPORT will add the CE mark to every appropriate device upon certification.

© Copyright 1998, NEWPORT Electronics, Inc. All rights reserved.

This documentation may not be copied, photocopied, reproduced, translated, or reduced to any electronic medium or machine-readable form, in whole or in part, without prior written consent of NEWPORT Electronics, Inc.

CHG	ECO NO	DATE	BY
D	9328	29 MAY 98	ML

OWNERS' MANUAL TABLE OF CONTENTS

MAIN ASSEMBLY 502A-K

Safety Considerationsii
1.0 General Information1
2.0 Specifications2
3.0 Safety Instructions3
4.0 Power and Signal Connections4
5.0 Configuration5
5.1 Tools and Equipment5
5.2 Calibration Procedure, Ambient Thermometer6
5.3 Calibration Procedure, Ice-Point Cell and T/C8
5.4 Pin Assignments12
5.5 Calibration Formula13
6.0 Mechanical Assembly and Installation15
6.1 General Information15
6.2 Optional Adapter Mounting15
6.3 Surface and TR2/2TK Relay Track Mounting Procedure15
6.4 DIN-EN-50 022 Relay Track Mounting Procedure16
6.5 External Explosion-Proof Housing Mounting Procedure17
7.0 Drawings18

ILLUSTRATIONS

Figure 4-1 Power Input Connections4
Figure 5-1 Exploded View5
Figure 5-2 Copper-Wire Calibration8
Figure 5-3 Calibration Setup9
Figure 5-4 Jumper Diagram12
Figure 6-1 Surface and TR2/2TK Relay Track Mounting15
Figure 6-2 DIN-EN-50 022 Relay Track Mounting16
Figure 6-3 External Explosion-Proof Housing Mounting17
Figure 7-1 502A-K Case Dimensions18
Figure 7-2 502A-K Preamp Block Diagram19
Figure 7-3 502A-K Postamp Block Diagram19
Table 5-1 NBS Type K Output and Slope (Sensitivity)10
Table 5-2 Temperature Ranges Obtained with Jumpers Used14

APPENDICES

Appendix A Transmitter Accuracy Factors20
---	-----

SAFETY CONSIDERATIONS



This device is marked with the international Caution symbol. It is important to read this manual before installing or commissioning this device as it contains important information relating to Safety and EMC (Electromagnetic Compatibility).

Unpacking & Inspection

Unpack the instrument and inspect for obvious shipping damage. Do not attempt to operate the unit if damage is found.



This instrument is a panel mount device protected in accordance with Class I of EN 61010 (115/230 AC power connections). Installation of this instrument should be done by Qualified personnel. In order to ensure safe operation, the following instructions should be followed.

This instrument has no power-on switch. An external switch or circuit-breaker shall be included in the building installation as a disconnecting device. It shall be marked to indicate this function, and it shall be in close proximity to the equipment within easy reach of the operator. The switch or circuit-breaker shall not interrupt the Protective Conductor (Earth wire), and it shall meet the relevant requirements of IEC 947-1 and IEC 947-3 (International Electrotechnical Commission). The switch shall not be incorporated in the mains supply cord.

Furthermore, to provide protection against excessive energy being drawn from the mains supply in case of a fault in the equipment, an overcurrent protection device shall be installed.



- The **Protective Conductor** must be connected for safety reasons. Check that the power cable has the proper Earth wire, and it is properly connected. It is not safe to operate this unit without the Protective Conductor Terminal connected.



- Do not exceed voltage rating on the label located on the top of the instrument housing.
- Always disconnect power before changing signal and power connections.
- Do not use this instrument on a work bench without its case for safety reasons.
- Do not operate this instrument in flammable or explosive atmospheres.
- Do not expose this instrument to rain or moisture.

EMC Considerations

- Whenever EMC is an issue, always use shielded cables.
- Never run signal and power wires in the same conduit.
- Use signal wire connections with twisted-pair cables.
- Install Ferrite Bead(s) on signal wires close to the instrument if EMC problems persist.

1.0 GENERAL INFORMATION

The 502A-K two-wire transmitter takes in microvolt signals generated by a type K thermocouple, provides cold (reference) junction compensation, amplification, common-mode isolation, and controls the current drawn from a 9-to-50 V dc source to produce the 4-to-20 milliampere output signal.

Common-mode voltage between the input thermocouple and the output current circuit is tested at 1500 V rms. As much as 750 ohms dropping resistance may be used in the power leads of the 502A-K when the unit is energized from a 24 V dc source because of the small compliance voltage needed by the unit. Accidental overloads of over one minute by 120 V rms on either input or output leads do not damage the 502A-K.

1.1 ACCURACY AND STABILITY

The 502A-K has tailored resistance values installed to provide curvilinear cold-junction compensation matched to the NBS K thermocouple table. Selected bridge resistors in a temperature-sensing bridge also provide cancellation of Span temperature effects. High-ambient-temperature compensation points are checked. The unit is certified for accuracy from -40 to +85°C (-104°F to +185°F).

1.2 ADAPTABILITY/TURNDOWN

The Span of the 502A-K can be ranged anywhere from 100°C to 1300°C by selection of one of four jumper positions, with fine tuning provided by a multiturn, top-accessible potentiometer. Sixteen Zero steps, also provided by 502A-K jumpers, allow placement of the 4-mA output temperature anywhere from -50°C to 1150°C, with fine tuning provided by another top-accessible, multiturn potentiometer. This 502A-K turndown capability exceeds that of any other known transmitter.

1.3 LINEARITY

The span and zero suppression capabilities (high turndown ratio) allow high-gain control for continuous processes and close conformity to the NBS tables over narrow temperature ranges. Downstream linearization of the 4-20 mA signal is required for accurate absolute temperature readout over a wide span.

1.4 ELECTRICAL ISOLATION

502A-K input (thermocouple and shield) and output (DC power) barrier strips accept wires up to two mm in diameter (13 gauge), and are mechanically isolated from each other to prevent input/output wiring contact during installation.

1.5 SHOCK RESISTANCE

Lightweight 502A-K circuit boards are formed into a rigid box structure and firmly soldered and epoxied to the case top. The circuit-board box is doubly coated with RTV silicone for environmental protection. When installed in the rugged, die-cast case, the 502A-K can withstand the shock of a 6-foot drop onto a hard surface (although scarring of the case and/or deformation of the plastic cover can occur).

1.6 WATERPROOF/RFI-RESISTANT CASE

The 502A-K case is made from Zamac (zinc alloy), coated with polyurethane, and gasketed with fluorosilicone. Fluorosilicone plugs protect the top-access Span and Zero potentiometers.

1.7 MOUNTING ADAPTABILITY

The small size of the 502A-K (less than 75 mm or 3 in OD) permits mounting in many small spaces, including explosion-proof housings for wiring compatibility with other equipment in hazardous environments. A bulkhead adaptor provides for wall-mounting. A snaptrack adaptor mounts on either American or European relay tracks. Tapped holes in the case rear provide for custom mounting on any surface, indoor or out. An optional opaque top cover shields the barrier strips from uneven heating or cooling in exposed environments.

1.8 FIELD SERVICEABILITY

Serviceability of the 500 Series transmitters is limited to zero and span adjustment, as described in this owners manual. This limitation is required because the accuracy and stability depend upon factory-matched and graded components. For environmental protection and structural strength, Newport transmitters have conformally-coated circuitry and box-soldered construction, which also inhibit field repair.

2.0 SPECIFICATIONS

2.1 INPUT

Configuration: Isolated input

Thermocouple type: K ("Chromel/Alumel")

Input impedance:	5 megohms
Thermocouple break-detect current:	50 nA max
Burnout indication:	Selectable up or down overscale
Thermocouple lead resistance:	Up to 500 ohms for specified performance
Common mode voltage, input to case:	Test, 2100 V peak; IEC spacing for over 354 V peak
Common mode rejection, input to case:	100 dB min at 60 Hz
Overvoltage protection	120 V ac max/1 min exposure

2.2 OUTPUT

Linear range:	4 mA to 20 mA dc
Compliance (supply-voltage range):	9 to 50 V dc
Overvoltage protection:	120 V ac
Reverse polarity protection:	400 V peak
Common mode voltage, output to case:	1500 V ac max
Common mode rejection, output to case:	100 dB min at 60 Hz

2.3 ACCURACY

Hysteresis and repeatability: Within $\pm 0.2^{\circ}\text{C}$ $\pm 0.1\%$ of Span
Conformity, 100°C Span: $\pm 1^{\circ}\text{C}$
Six month stability: Within $\pm 0.2^{\circ}\text{C}$ $\pm 0.2\%$ of base temperature
Power supply effect: Within $\pm 0.005\%/V$

Ambient temperature effect
for 50°C change: Zero and conformity: Within $\pm 0.5^{\circ}\text{C}$
Span: Within 0.2%
Suppression: $\pm 0.2\%$ of base temperature

2.4 ENVIRONMENTAL

Operating temperature: -40 to 85°C
Storage temperature: -55 to 125°C
Humidity: To 99% (Splashproof)
Vibration: 1.52 mm ($.06$ in) double amplitude,
 10 - 80 Hz cycled
Shock: $55g$, half-sine, 9 - 13 msec duration,
 $6'$ drop to hard surface
Watertight pressure limit: 35 kPa (5 psi)
Mounting position: Any

2.5 MECHANICAL

Case material: Zamac (zinc alloy), polyurethane-
coated, fluorosilicone-gasketed
Weight: 300 g (10 oz)
Diameter: 74 mm (2.9 in)
Height (including barriers): 52 mm (2.1 in)
Connections: #6 screws with wire clamps

3.0 SAFETY INSTRUCTIONS

As delivered from the factory/distributor, this instrument complies with required safety regulations. In order to maintain this condition and to ensure safe operation, the following instructions should be followed.

1. Unpacking - After visual inspection, do not attempt to operate the unit if damage is found.
2. Power Voltage - Check that the instrument is connected for the correct power voltage (9 - 50 V dc).
3. Mounting - Observe the specifications in Section 2.4 to ensure that mounting meets environmental requirements.
4. Power Wiring - This instrument has no mains switch; it will be in operation as soon as the power is connected.
5. Signal Wiring - Do not make signal wiring connections or changes when power is applied to the instrument; make signal connections before power is applied and, if reconnection is required, disconnect the power before rewiring is attempted.
6. Exercise Caution - As with any electronic instrument, high voltage may exist when attempting to install, calibrate, or remove parts of the meter.

4.0 POWER AND SIGNAL CONNECTIONS

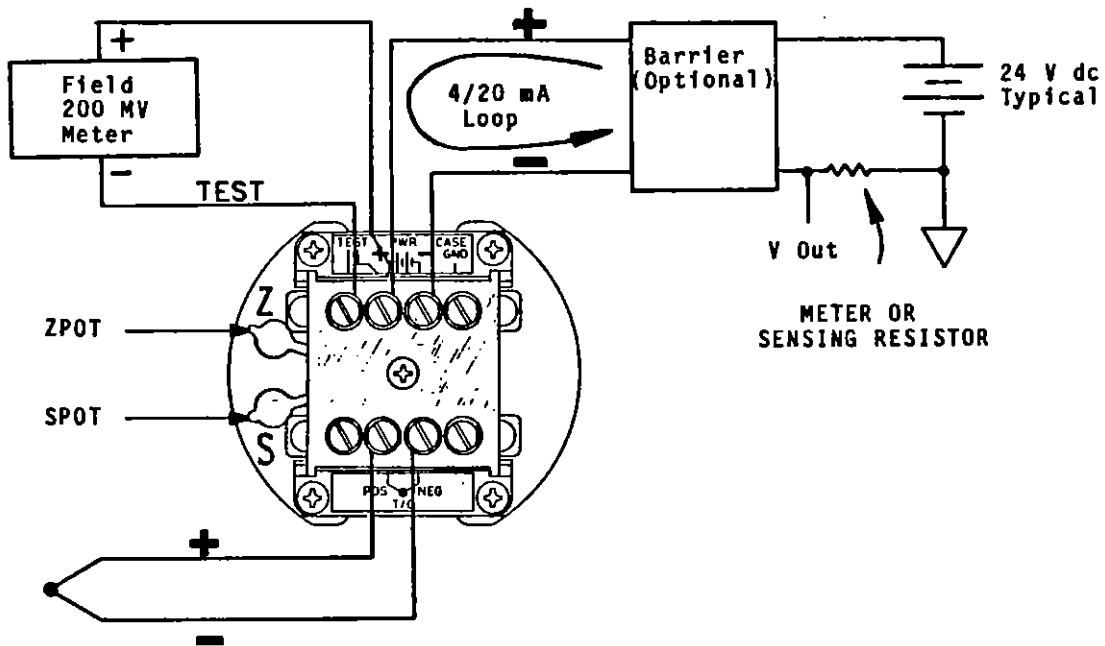

Figure 4-1 Power Input Connections

4.1 GENERAL

TEST, PWR +, and PWR - screws accept 2 mm (13 gauge) or lighter wire. CASE GND is grounded to the case. Input range is 9-50 V dc.

SCREW-TERMINAL PIN ASSIGNMENT

1	TEST
2	+ POWER/OUTPUT
3	- POWER/OUTPUT
4	CASE GND
A	N/C
B	+ TC
C	-TC
D	N/C

5.0 CONFIGURATION

The 502A-K is normally delivered configured for $4/20 \text{ mA} = 0/800^\circ\text{C}$.
Basic reconfiguration procedures are listed in Sections 5.2 and 5.3.
Calibration formulas are included in Section 5.5.

5.1 TOOLS AND EQUIPMENT

#1 Phillips screwdriver
VACO 17764 or equivalent flathead screwdriver
Two 4 1/2 digit DVM voltage meters
10 ohm or 100 ohm 1% resistor
Fixed or variable DC power supply or battery (in the range of
11-30 V dc)

Ambient temperature readout
Microvolt calibration source (in the range of -2000 to 55000 UV)
KAYE 140 or equivalent 0°C ice-point cell (Optional)

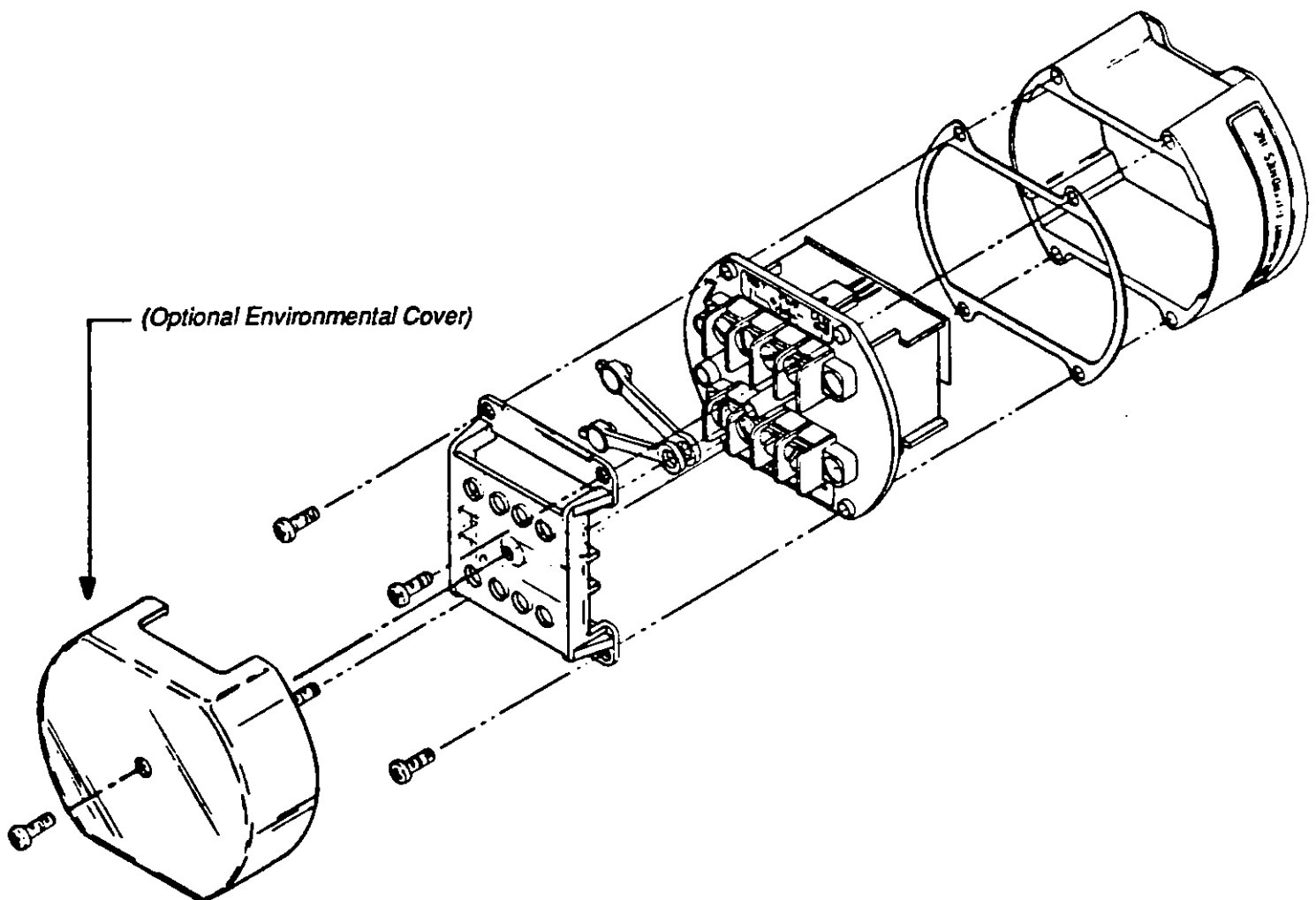

Figure 5-1 Exploded View

5.2 CONFIGURATION AND CALIBRATION PROCEDURE USING AMBIENT THERMOMETER

1. Refer to Figure 5-1. Remove the four Phillips-head screws from the 502A-K case top, and set aside the plastic barrier cover.
2. Lift out the electronics assembly (attached to the case lid).
3. Setting aside the case and sealing gasket, pull out the two sealing plugs which cover the Span and Zero potentiometers (**SPOT** and **ZPOT**). Adjust SPOT to about 3/4 CCW. SPOT is never more than 3/4 CW; ZPOT can be anywhere.
4. Refer to Figure 5-2, Page 6. Attach two insulated copper wires to the 502A-K T/C input terminals from the microvolt calibration source (twisted-shielded pair recommended for pickup rejection).

Note: Microvolt source + to T/C Pos, Microvolt source - to T/C Neg.

5. Attach two insulated copper wires from the output terminals, connecting the + terminal to the + terminal of a 11-to-30 V power supply or battery, and the - terminal to the + terminal of an ammeter. Close the 4/20 mA loop by connecting the - terminal of the ammeter to the - terminal of the power source.
6. Refer to Table 5-3 for Temperature Range Zero and Span jumper positions. Turn the 502A-K so that the jumper pin-forest is at hand, and move the five push-on jumpers to the positions indicated in Figure 5-4 for the jumpers chosen from Table 5-2 to yield the desired Zero and Span ranges.

Note: Better calibration stability is obtained if the electronic assembly is installed in the case.

7. Put the accurate temperature probe as close as possible to the 502A-K input terminals (insulating attachment tape can be used).
8. Using Table 5-1, determine the amount of microvolts that the ambient (Room) temperature represents. Subtract this from the microvolts corresponding to the desired Base Temperature, also found in Table 5-1. This value is **LO-IN**.
9. Set the microvolt calibration source to LO-IN microvolts and adjust ZPOT for 4.00 mA output current.
10. Using Table 5-1, subtract the ambient microvolts from the microvolts for the desired Top Temperature. This value is **HI-IN**.
11. Set the microvolt calibration source to HI-IN microvolts and read the output current, designated IFT (normally not equal to 20 mA).
12. Calculate $IFS = 16 \cdot IFT / (IFT - 4)$ milliamperes. (In general IFS will also not be equal to 20 mA.)
13. Adjust SPOT to obtain the IFS output.
14. Now readjust ZPOT so that the output reads 20.00 mA.

15. Set the microvolt calibration source to LO-IN microvolts. If the output current is not 4.00 mA, retrim starting at Item 9, above.
16. When calibrated, remove wires, replace pot sealing plugs, and install unit in the case with firmly compressed (but not flattened) gasket for a good seal, using the four screws.

EXAMPLE:

Temperature Range = -50 to 350°C

Base Temperature = -50°C

Top Temperature = 350°C

Z Jumpers None Table 5-2

Span Jumper E Table 5-2

Ambient Temperature = 25°C Temperature Readout

Ambient Microvolt at 25°C = 1000.2 Table 5-1

Base Temperature Microvolt at -50°C = -1889.07 Table 5-1

Top Temp (Max.) Microvolt at 350°C = 14292.2 Table 5-1

LO-IN = -1889.07 - 1000.2 = -2889.27

HI-IN = 14292.2 - 1000.2 = 13292.0

Calibrate:

1. Set SPOT to about 3/4 CCW.
2. Set microvolt source to -2889.
3. Adjust ZPOT to 4.00 mA.
4. Set microvolt source to 13292.
5. Read current, designated IFT.
6. Calculate IFS = $16 \cdot \text{IFT} / (\text{IFT} - 4) \text{mA}$.
7. Adjust SPOT to obtain IFS current.
8. Adjust ZPOT to obtain 20 mA current.
9. Set microvolt source to -2889.
10. If the output is not 4.00 mA, retrim starting at Item 2 above.

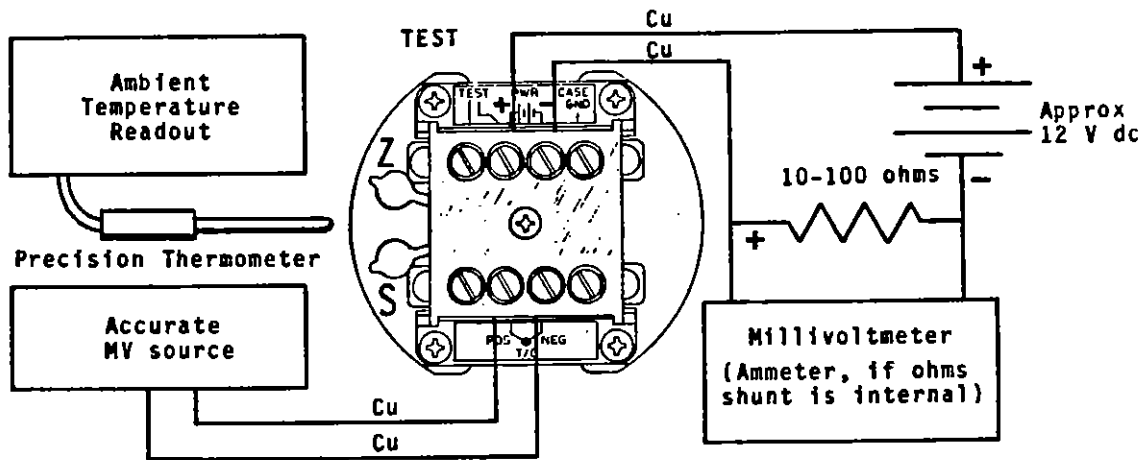

Figure 5-2 Copper-Wire Calibration
Using Room-Temperature Thermometer

5.3 CONFIGURATION AND CALIBRATION PROCEDURE USING ICE-POINT CELL

1. Referring to Figure 5-1, remove 4 Phillips-head screws from top of 502A-K case, and lift out the electronics..
2. Refer to Table 5-2 for Temperature Range Zero and Span jumper positions. Move the five push-on jumpers to the positions indicated in Figure 5-4 for the jumpers chosen from Table 5-2. This will yield the desired temperature range.

Note: Better calibration stability is obtained if the electronic assembly is installed back into the case.

3. Pull out two sealing plugs that cover 502A-K Span and Zero potentiometer screw heads. Set SPOT to about 3/4 CCW; ZPOT can be anywhere.
4. Referring to Figure 5-3, hook up the calibration and output circuits.
5. Using Table 5-1, determine the microvolt level for the desired Base Temperature.
6. Set the microvolt calibration source to these Base Temperature microvolts.
7. Adjust ZPOT for 4.00 mA out.
8. Using Table 5-1, determine the microvolts for the desired Top Temperature.
9. Set the microvolt calibration source to these Top Temperature microvolts.
10. Without adjusting SPOT, read the output current, designated IFT (not yet 20 mA).

11. Calculate $IFS = 16 \cdot IFT / (IFT - 4)$ milliamperes. (In general, IFS will not be equal to 20 mA.)
12. Adjust the SPOT to obtain the IFS output.
13. Now readjust the ZPOT so that the output reads 20.00 mA.
14. Set the microvolt calibration source back to the Base Temperature microvolts. If the output is not 4.00 mA, retrim starting at Item 7, above.
15. Remove 502A-K from calibration setup.
16. Replace two sealing plugs over 502A-K Span and Zero potentiometer screw heads.
17. Replace 502A-K main unit in casing. Be sure fluorosilicone gasket is firmly compressed, but not entirely flattened, to ensure a good seal.
18. Replace 4 Phillips-head screws that hold 502A-K unit to case.

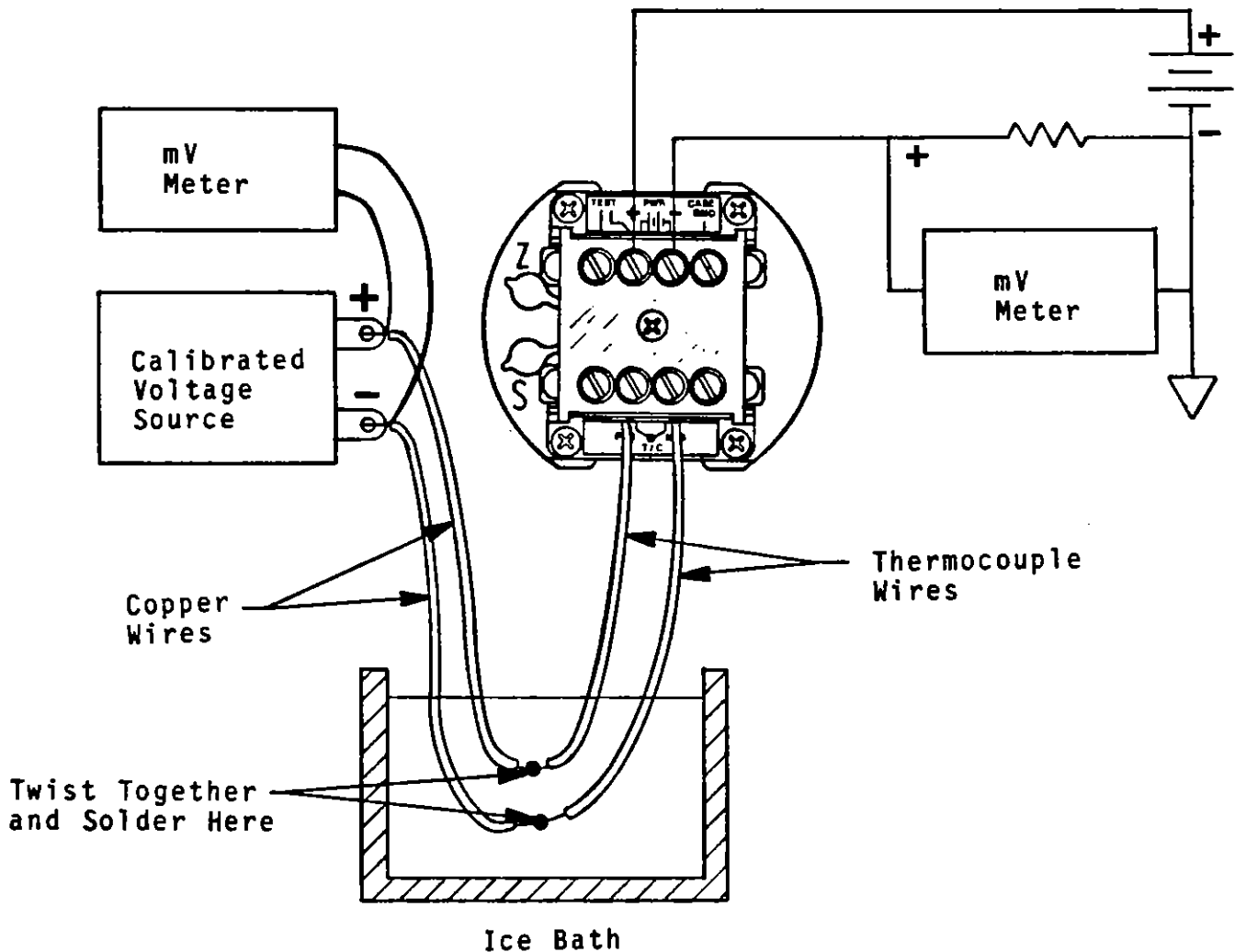

Figure 5-3 Calibration Setup

T °C	E μV	S μV/°C	T °C	E μV	S μV/°C
-270	-6457.82	0.739	80	3265.70	41.541
-260	-6441.15	2.664	85	3473.30	41.526
-250	-6403.68	4.853	90	3680.90	41.492
-240	-6343.92	7.096	100	4095.30	41.371
-230	-6261.93	9.288	110	4508.10	41.191
-220	-6158.49	11.383	120	4919.00	40.969
-210	-6034.63	13.373	130	5327.40	40.727
-200	-5891.36	15.264	140	5733.50	40.485
-190	-5729.62	17.070	150	6137.20	40.266
-180	-5550.21	18.802	160	6538.90	40.087
-170	-5353.80	20.469	170	6939.20	39.963
-160	-5141.03	22.076	180	7338.40	39.899
-150	-4912.48	23.626	190	7737.30	39.898
-140	-4668.71	25.118	200	8136.60	39.953
-130	-4410.30	26.553	210	8536.60	40.058
-120	-4137.85	27.927	220	8937.80	40.199
-110	-3851.96	29.241	230	9340.60	40.364
-100	-3553.23	30.494	240	9745.20	40.542
-90	-3242.30	31.684	250	10151.50	40.722
-80	-2919.77	32.811	260	10559.60	40.896
-70	-2586.30	33.874	270	10969.30	41.058
-60	-2242.51	34.872	280	11380.70	41.207
-50	-1889.07	35.805	290	11793.40	41.340
-45	-1708.94	36.246	300	12207.40	41.459
-40	-1526.64	36.672	310	12622.60	41.565
-35	-1342.25	37.081	320	13038.70	41.660
-30	-1155.85	37.474	330	13455.70	41.746
-20	-777.38	38.211	340	13873.60	41.825
-15	-585.45	38.555	350	14292.20	41.899
-10	-391.86	38.881	360	14711.60	41.969
-5	-196.67	39.189	370	15131.60	42.035
0	0.00	39.475	380	15552.30	42.099
5	197.90	39.699	390	15973.60	42.159
10	397.00	39.914	400	16395.40	42.217
15	597.10	40.118	410	16817.90	42.273
20	798.10	40.313	420	17240.90	42.325
25	1000.20	40.498	430	17664.40	42.375
30	1203.10	40.670	440	18088.40	42.421
35	1406.90	40.831	450	18512.80	42.464
40	1611.40	40.977	460	18937.60	42.502
45	1816.60	41.109	470	19362.80	42.536
50	2022.40	41.226	480	19788.40	42.566
55	2228.80	41.325	490	20214.10	42.592
60	2435.70	41.407	500	20640.20	42.612
65	2642.90	41.470	510	21066.40	42.628
70	2850.30	41.513	520	21492.70	42.638
75	3058.00	41.537			

Table 5-1 NBS Type K Output and Slope (Sensitivity)

T °C	E μV	S μV/°C	T °C	E μV	S μV/°C
530	21919.10	42.643	950	39309.60	39.439
540	22345.50	42.643	960	39703.40	39.337
550	22771.90	42.637	970	40096.30	39.234
560	23198.30	42.626	980	40488.10	39.132
570	23624.40	42.609	990	40878.90	39.029
580	24050.40	42.587	1000	41268.70	38.926
590	24476.20	42.560	1010	41657.50	38.823
600	24901.60	42.527	1020	42045.20	38.719
610	25326.70	42.489	1030	42431.80	38.614
620	25751.40	42.445	1040	42817.50	38.509
630	26175.60	42.397	1050	43202.00	38.402
640	26599.30	42.344	1060	43585.50	38.293
650	27022.40	42.286	1070	43967.90	38.183
660	27445.00	42.224	1080	44349.10	38.071
670	27866.90	42.157	1090	44729.30	37.957
680	28288.10	42.086	1100	45108.30	37.840
690	28708.60	42.011	1110	45486.10	37.720
700	29128.30	41.933	1120	45862.70	37.598
710	29547.20	41.851	1130	46238.00	37.473
720	29965.30	41.766	1140	46612.10	37.344
730	30382.50	41.678	1150	46984.90	37.212
740	30798.90	41.587	1160	47356.30	37.077
750	31214.30	41.494	1170	47726.40	36.937
760	31628.70	41.398	1180	48095.10	36.795
770	32042.20	41.301	1190	48462.30	36.649
780	32454.70	41.202	1200	48828.00	36.499
790	32866.30	41.102	1210	49192.30	36.346
800	33276.80	41.000	1220	49555.00	36.190
810	33686.30	40.897	1230	49916.10	36.032
820	34094.70	40.794	1240	50275.60	35.871
830	34502.10	40.689	1250	50633.50	35.708
840	34908.50	40.585	1260	50989.70	35.545
850	35313.80	40.480	1270	51344.40	35.381
860	35718.10	40.375	1280	51697.40	35.217
870	36121.30	40.270	1290	52048.70	35.055
880	36523.50	40.165	1300	52398.50	34.897
890	36924.60	40.061	1310	52746.70	34.742
900	37324.70	39.956	1320	53093.30	34.593
910	37723.80	39.852	1330	53438.60	34.451
920	38121.80	39.748	1340	53782.40	34.319
930	38518.70	39.645	1350	54125.00	34.199
940	38914.70	39.542	1360	54466.40	34.093
			1370	54806.90	34.004

Table 5-1 Continuation

Example: For 28.2°C, use $1000.2 + (3.2)40.5 = 1129.8$ uV or, slightly more accurately, $1203.1 - (1.8)40.67 = 1129.9$ uV.

5.4 PIN ASSIGNMENTS (Jumper Pin-Group P1)

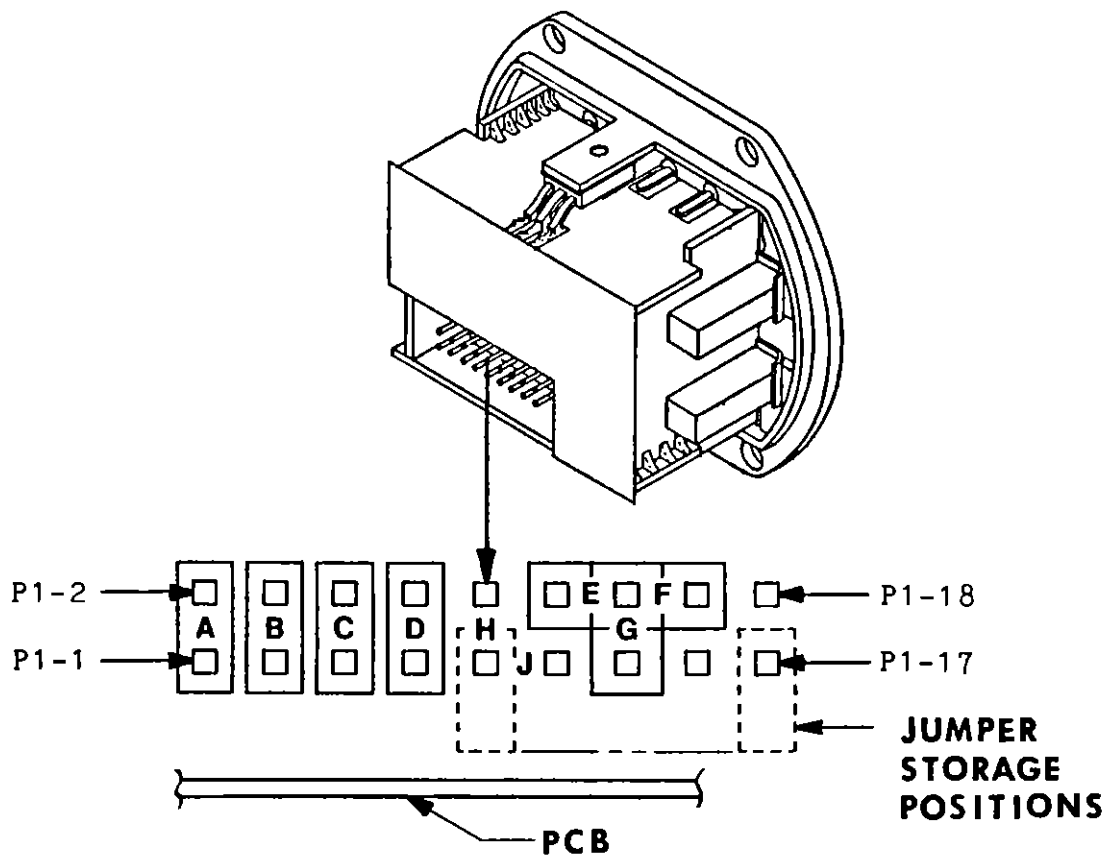

Figure 5-4 Jumper Diagram

<u>Jumper Function</u>	<u>P1 Pins Used</u>
'A' Zero	1 and 2
'B' Zero	3 and 4
'C' Zero	5 and 6
'D' Zero	7 and 8
'E' Span	12 and 14
'F' Span	14 and 16
'G' Span	13 and 14

NOTE: P1 connector pins 9, 10, 11, 15, 17 and 18 are used solely for computerized testing by the factory.

5.5 CALIBRATION FORMULA (Alternate to Using Base/Top Tables)

5.5.1 Calculation of ZEXTRA

When the SPAN pot is turned Clockwise it increases the output, decreasing the SPAN required for full-scale output and adding ZEXTRA, which is used to set the Zero (Base Temperature) jumpers.

$$\text{ZEXTRA} = (\text{MAXSPAN} - \text{SPAN}) / 4$$

5.5.2 Zero Jumper Selection (Equation alternate to Table 5-2)

From zero to four jumpers may be placed on the connector to suppress the ZERO (temperature corresponding to 4 mA output). The equation is:

$$(\text{ZERO} + \text{ZEXTRA}) = 90 (8A + 4B + 2C + D) + 70 \times \text{ZPOT}, \text{ } ^\circ\text{C}$$

where a "1" is used for each jumper (A,B,C,D) and the value of Zero pot ranges from +1.0 to 0 to -1.0 as it is turned clockwise.

NOTE: Store the unused jumpers between the bottom connector pins and the printed-circuit board as shown on in Figure 5-4.

WITHOUT SPAN JUMPERS			USING SPAN JUMPER 'E'		
<u>Z JUMPERS</u>	Base	Top	<u>Z JUMPERS</u>	Base	Top
NONE	-75	950 to 1325	NONE	-75	300 to 575
D (ONLY)	-25	1025 to 1372	D (ONLY)	-5	370 to 645
C (ONLY)	0	1075 to 1372	C (ONLY)	65	440 to 715
C AND D	75	1150 to 1372	C AND D	135	510 to 785
B (ONLY)	175	1225 to 1372	B (ONLY)	205	580 to 855
B AND D	275	1300 to 1372	B AND D	275	650 to 915
			B AND C	345	720 to 995
			B,C AND D	415	790 to 1065
			A (ONLY)	485	860 to 1135
			A AND D	555	930 to 1205
			A AND C	625	1000 to 1275

USING SPAN JUMPER 'F'			USING SPAN JUMPER 'G'		
<u>Z JUMPERS</u>	Base	Top	<u>Z JUMPERS</u>	Base	Top
NONE	-75	180 to 325	NONE	-75	20 to 155
D (ONLY)	5	260 to 405	D (ONLY)	0	100 to 235
C (ONLY)	85	340 to 485	C (ONLY)	85	180 to 315
C AND D	165	420 to 565	C AND D	165	260 to 395
B (ONLY)	245	500 to 645	B (ONLY)	245	340 to 475
B AND D	325	580 to 725	B AND D	325	420 to 555
B AND C	405	660 to 805	B AND C	405	500 to 635
B,C AND D	485	740 to 885	B,C AND D	485	580 to 715
A (ONLY)	565	820 to 965	A (ONLY)	565	660 to 795
A AND D	645	900 to 1045	A AND D	645	740 to 875
A AND C	725	980 to 1125	A AND C	725	820 to 955
A,C AND D	805	1060 to 1205	A,C AND D	805	900 to 1035
A AND B	885	1140 to 1285	A AND B	885	980 to 1115
A,B AND D	965	1220 to 1372	A,B AND D	965	1060 to 1195
			A,B AND C	1045	1140 to 1275

Table 5-2 Span Ranges In °C Obtained With Jumpers

Reference Sections 5.5.1 and 5.5.2.

6.0 MECHANICAL ASSEMBLY AND INSTALLATION

6.1 GENERAL INFORMATION

The low voltage requirement of the 502A-K enables its use with a current-loop indicator (Newport Model 508 recommended). Tapped holes on the back of the case provide for custom mounting to a flat surface; flanges on the back of the case provide for standard 8TK2 relay track mounting.

For flat surface mounting, use #6 hardware.
For 8TK2 relay track mounting, simply push onto track.

6.2 OPTIONAL ADAPTERS FOR MOUNTING

The following optional adaptors provide various mounting choices:

- a. Adaptor plate for either front-screw-entry surface mount, or TR2/2TK relay track mount (see Figure 6-1).
- b. Rail clamp for DIN-EN-50 022 relay track mount (Figure 6-2).
- c. Spring retainers for external 76.4 to 88.9 mm (3 to 3.5 in) explosion-proof housing mount (see Figure 6-3).

6.3 SURFACE AND TR2/2TK RELAY TRACK MOUNTING PROCEDURE

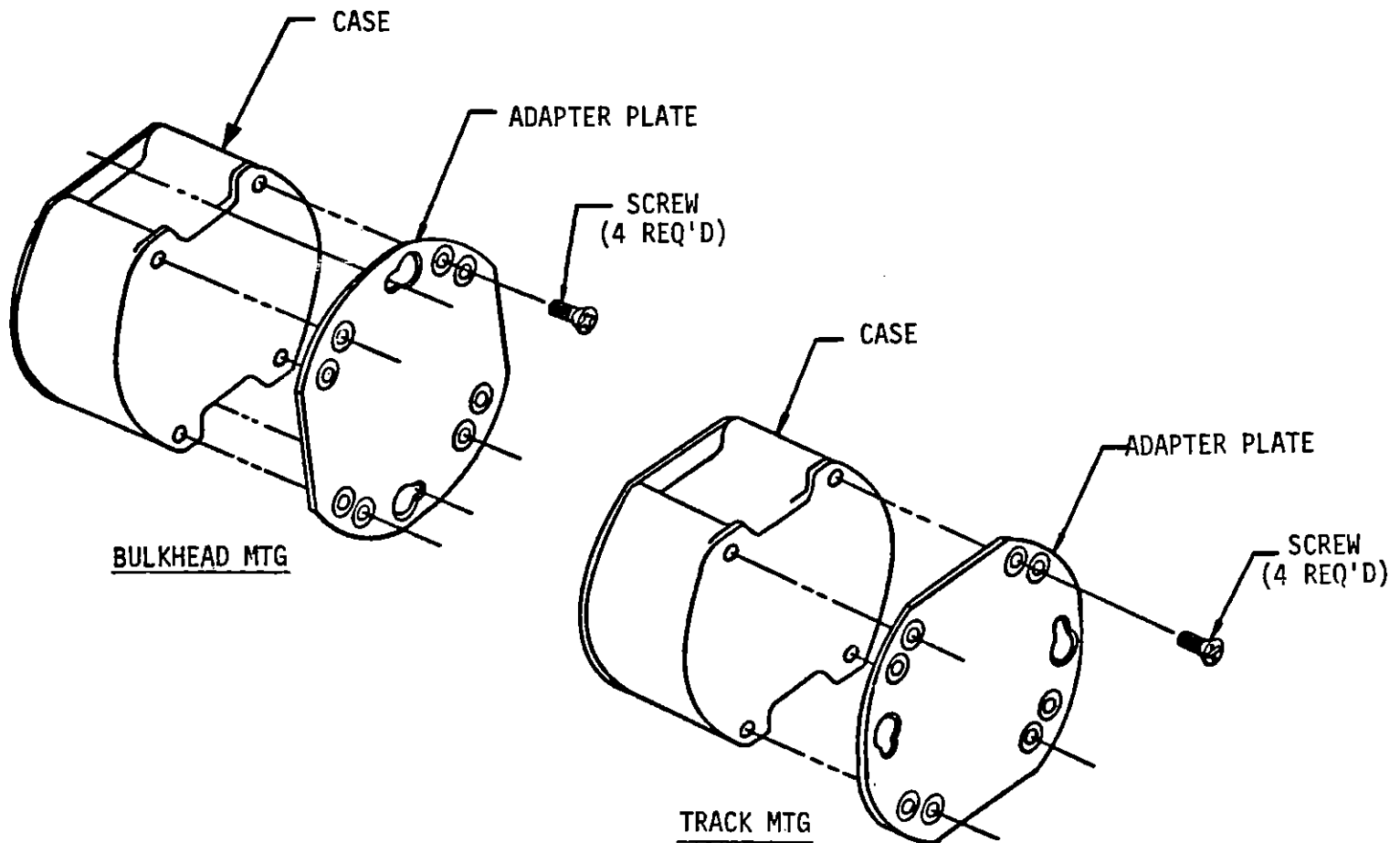

Figure 6-1 Bulkhead and Track Mounting

1. Position plate for desired application.
2. Use #6 hardware to mount plate to back of 502A-K case.

6.4 DIN EN-50-022 RELAY TRACK MOUNTING PROCEDURE

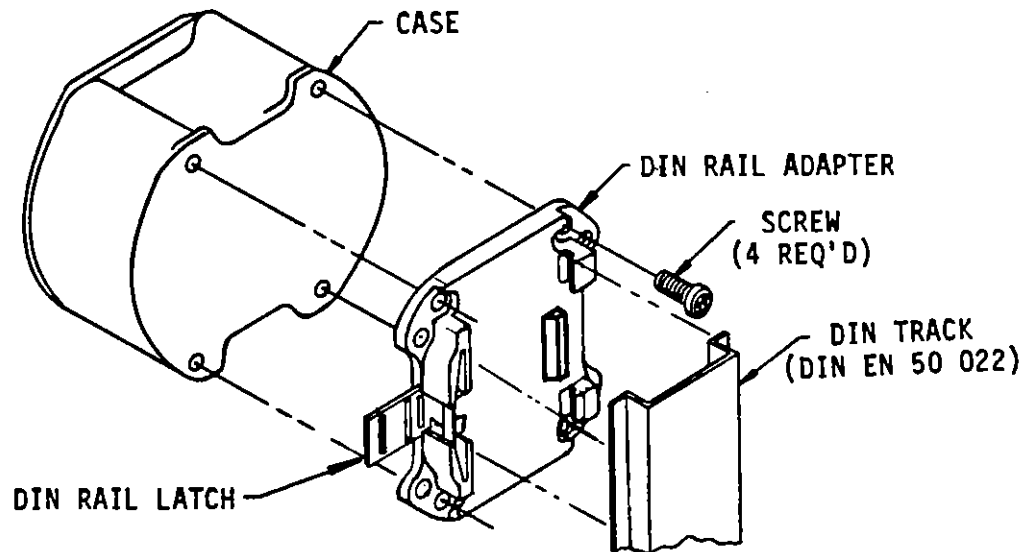
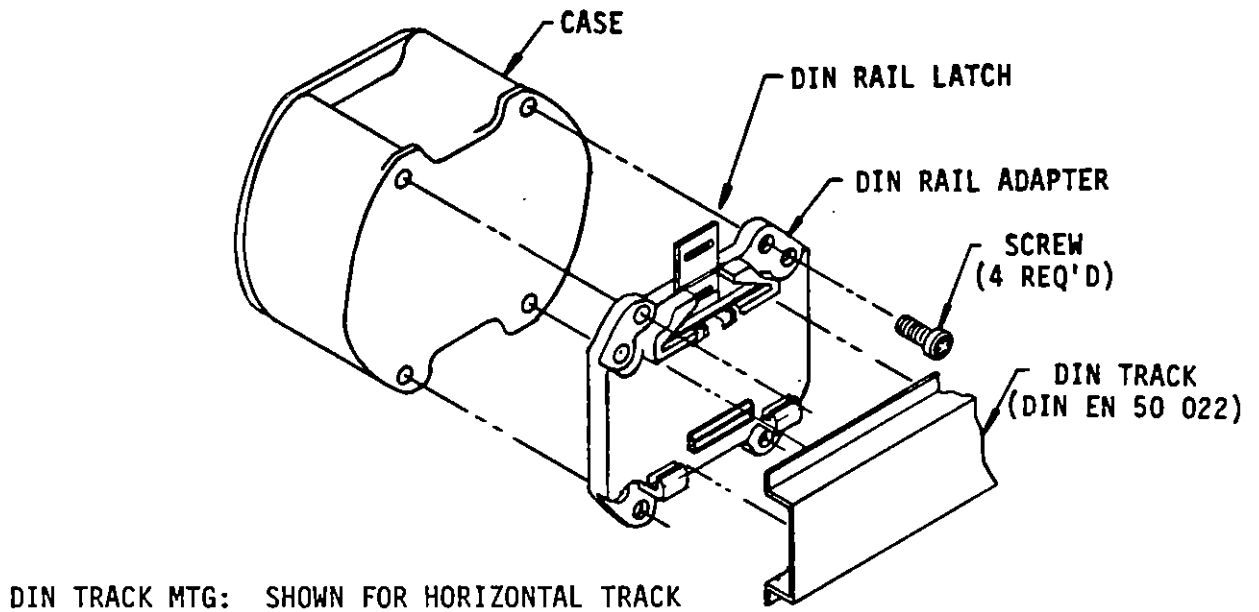

Figure 6-2 DIN Track Mounting

1. Position plate for desired track direction.
2. Use #8 flathead screws to mount plate to back of 502A-K case.
3. Snap 502A-K case assembly onto DIN rail.

6.5 EXTERNAL EXPLOSION-PROOF HOUSING MOUNTING

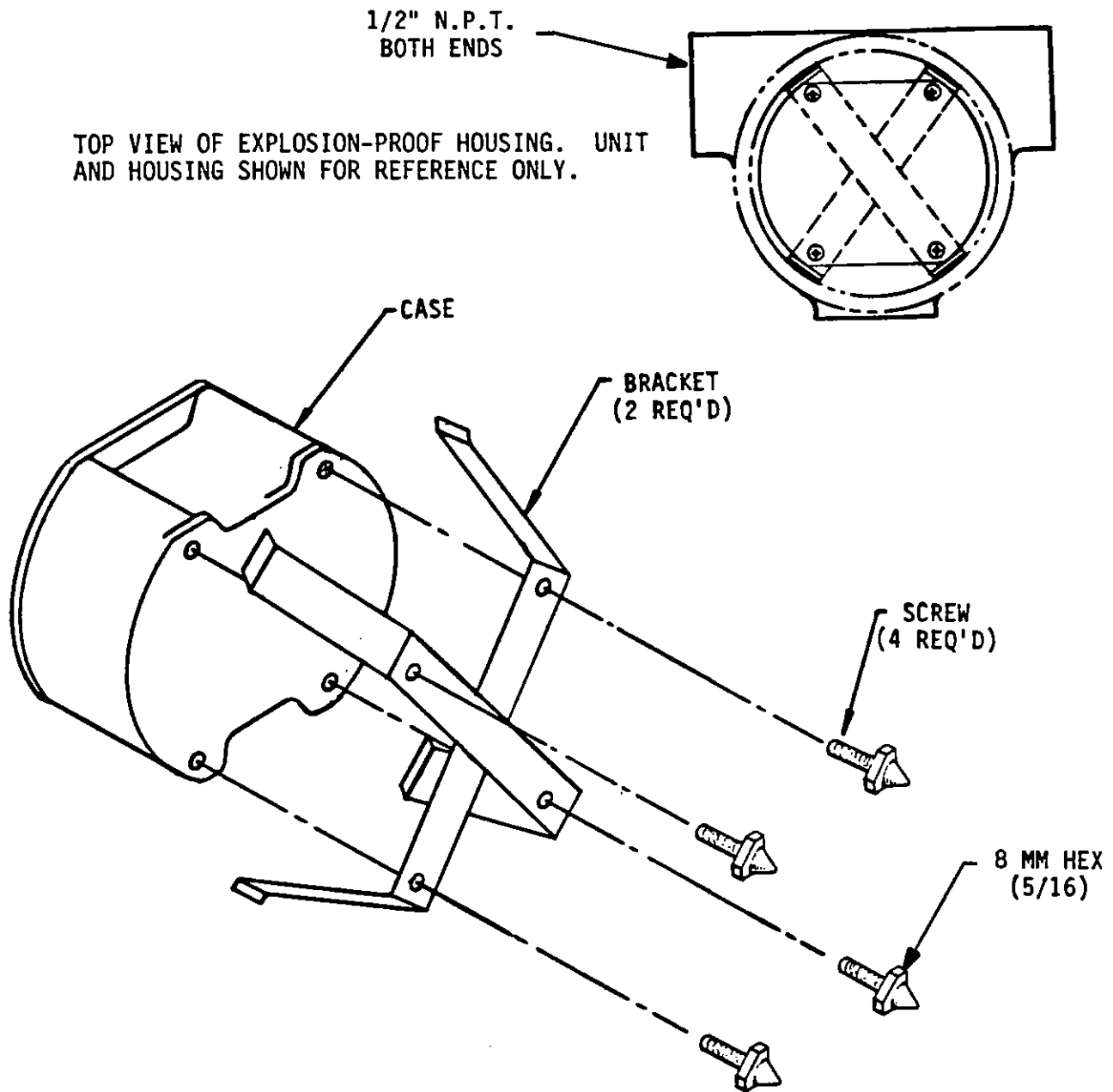
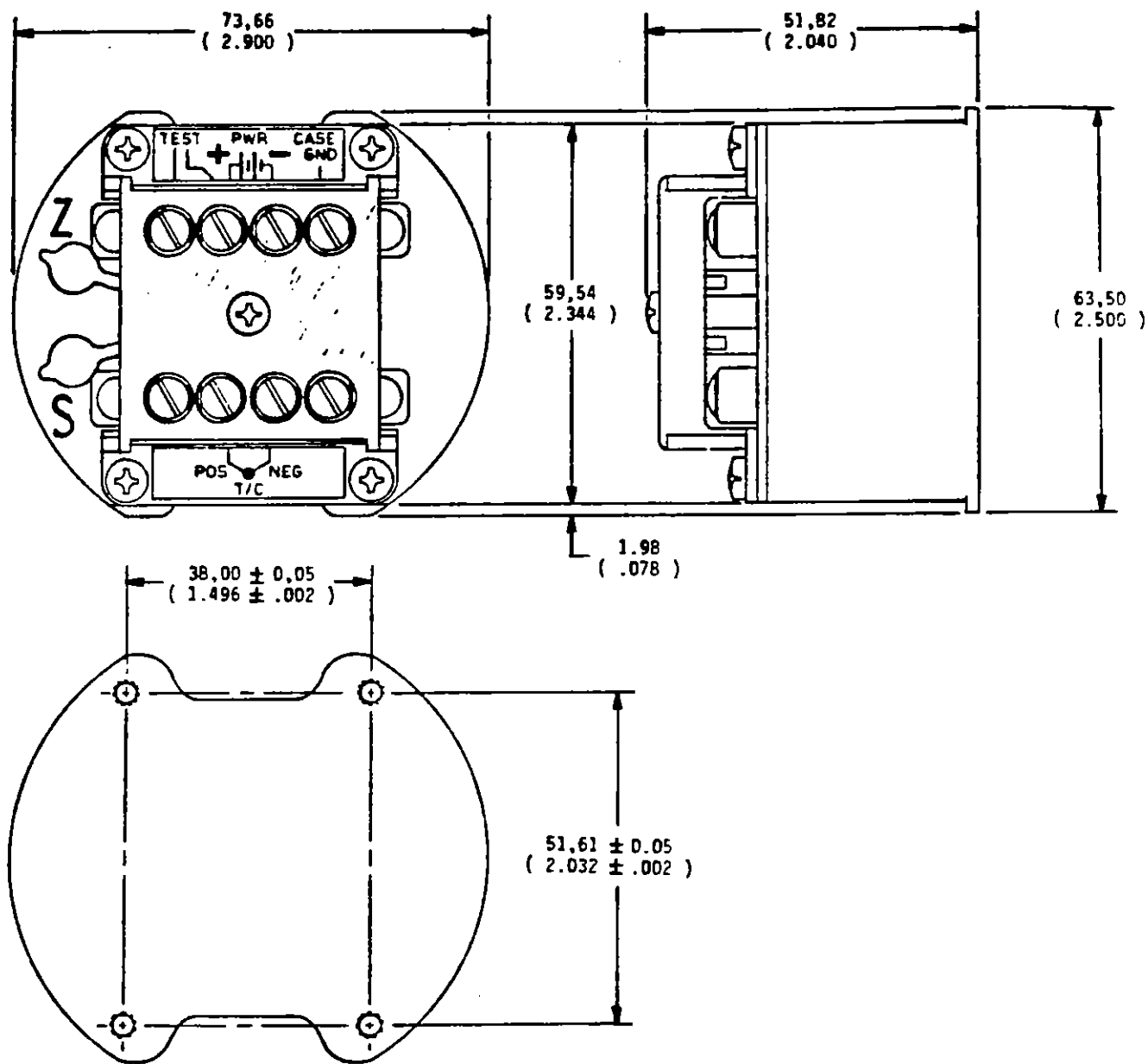

Figure 6-3 Spring Retainer for Explosion-Proof Housing

1. Position spring retainer across back of 502A-K case.
2. Use wire protector feet (4 provided with above option) to hold spring retainers in place.
3. Press 502A-K case assembly into explosion-proof housing.

7.0 DRAWINGS



REAR OF UNIT (MOUNTING)

Figure 7-1 502A-K Case Dimensions

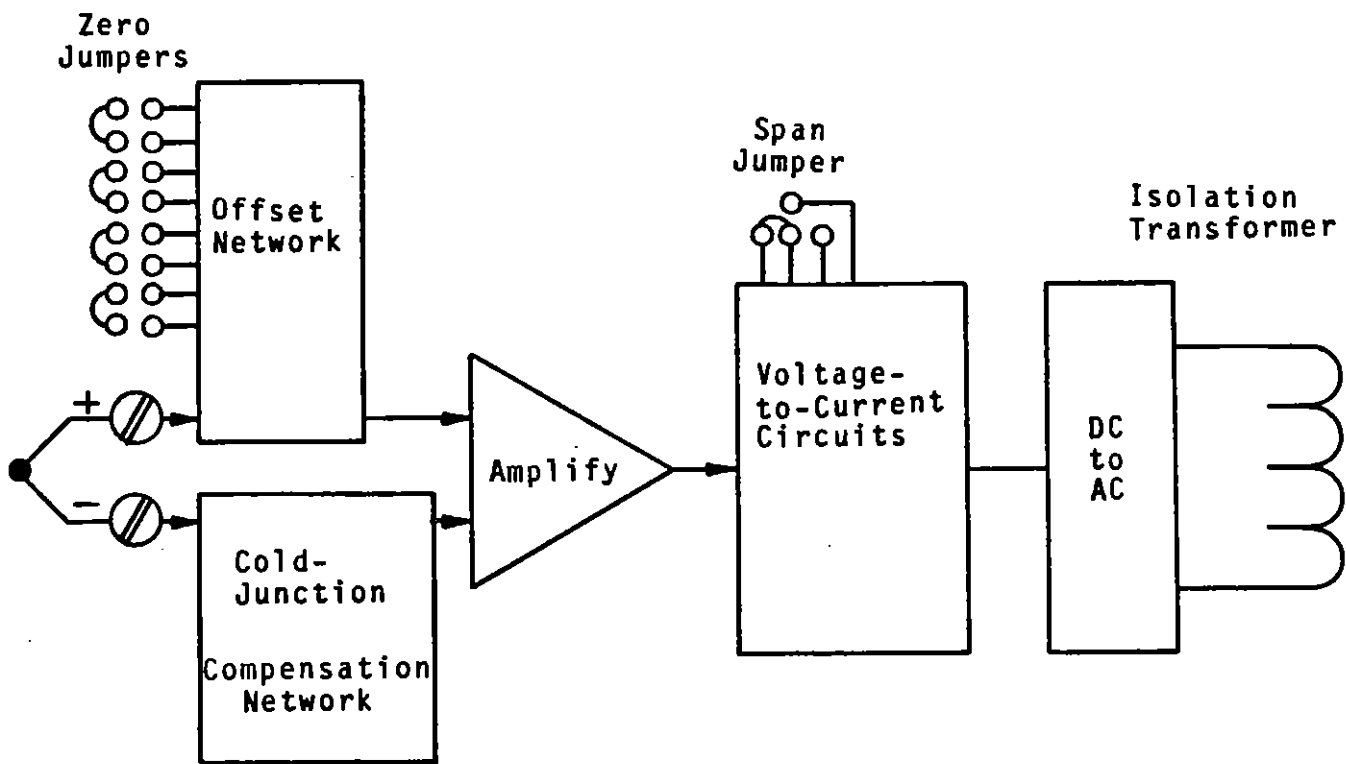

Figure 7-2 502A-K Preamp Block Diagram

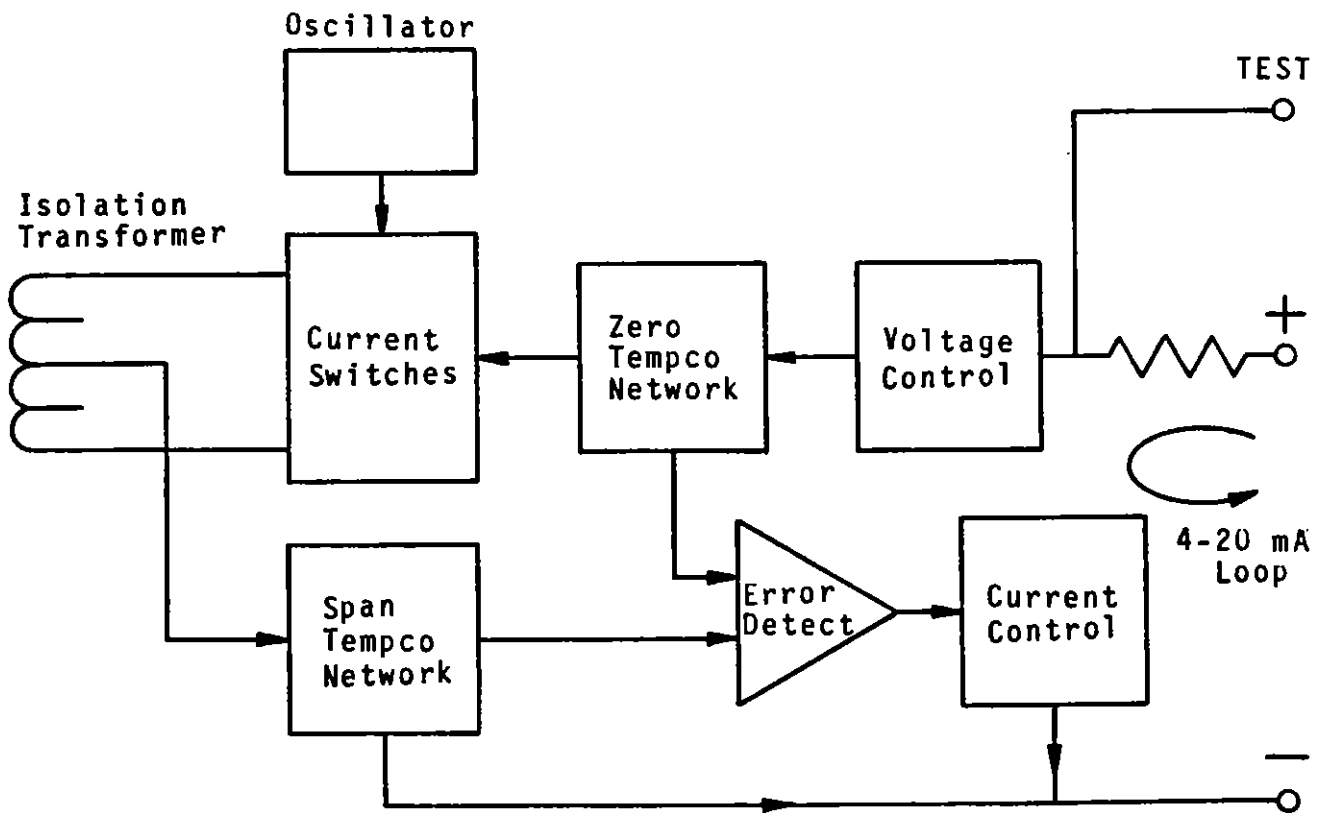

Figure 7-3 502A-K Postamp Block Diagram

APPENDIX A

TRANSMITTER ACCURACY SPECIFICATIONS

The complex current-transmitter circuitry necessary to amplify, isolate, protect, and offset weak input signals while consuming only small amounts of power can distort the signal in many ways. Additional accuracy limitations occur in thermocouple transmitters, which require precise cold-junction compensation and large Zero-suppression ranges in order to obtain good sensitivity and linearity for high temperatures.

Many transmitter data sheets omit key accuracy factors and/or express performance in percentage values without mentioning the full-scale value. Design limitations can be disguised by such "specsmanship"; the 502A-K specifications, however, are detailed in order to present the complete performance accuracy.

For a given thermocouple type, input errors are logically expressed in degrees (rather than microvolts), and output errors are readily expressed in microamperes, since output is current. Transmitter users are rarely interested in microamperes. Therefore, these output current errors are translated back to input degrees as a percentage (or ppm) of the selected Span.

Another fundamental division of errors is that of independence or dependence on Zero and Reading. Resistor aging and tempco mismatch in the Zero and Voltage Reference circuits will produce errors which increase with Zero suppression but which are independent of the amount of Reading (value above the Zero). Resistor aging and tempco mismatch in the amplifier gain (feedback) circuits will usually affect both Zero and Reading accuracy; amplifier gain tempco variations are important to just the Reading stability. A complete error specification needs a term proportional to Zero (suppression) and a term proportional to Reading.

For thermocouple transmitters, the Cold-Junction Compensation (CJC) is never perfect, even when factory-tailored over wide ambient excursions with curvilinear adjustments, as in the 502A-K. This error component is readily stated as a percentage of the ambient temperature excursion from the nominal temperature at which the Zero was set (assuming, as in the 502A-K, that the Zero potentiometer has ample resolution on all Zero and Span ranges). For transmitters with restricted turndown ratios (low Zero Suppression capability), the tempco errors may be lumped into a single error term.

In addition to these three components of tempco (ambient temperature effects), there are other possible errors, often referred to as "hysteresis," "repeatability," "drift," or "time" errors. No statistically-significant errors of these types have yet been observed for the 502A-K, which utilizes a solid-state, band-gap input voltage reference, matched-pair input PNP transistors, integrated-circuit current source and imbalance control, and matched-tempco bridge resistors. The 502A-K also provides a variable-tempco output adjustment (factory-set) which eliminates many of the errors lumped in this category for other units. Its specification includes a 0.2°C tolerance for the calibration accuracies.