

1 YEAR
WARRANTY



Ω OMEGA™ User's Guide

*Shop online at
omega.com*

*e-mail: info@omega.com
For latest product manuals:
omegamanual.info*



TX82B
Panel Mounted
Current Loop Indicator



omega.com info@omega.com

Servicing North America:

U.S.A.

Headquarters:

Omega Engineering, Inc.

Toll-Free: 1-800-826-6342 (USA & Canada only)

Customer Service: 1-800-622-2378 (USA & Canada only)

Engineering Service: 1-800-872-9436 (USA & Canada only)

Tel: (203) 359-1660

Fax: (203) 359-7700

e-mail: info@omega.com

For Other Locations Visit omega.com/worldwide

TABLE OF CONTENTS

1.0	GENERAL INFORMATION	1
2.0	SPECIFICATIONS	2
2.1	Input	2
2.2	Accuracy at 25°C	2
2.3	Analog-To-Digital Conversion	2
2.4	Display	3
2.5	Environmental	3
2.6	Mechanical	3
3.0	MECHANICAL ASSEMBLY AND INSTALLATION	4
3.1	Safety Considerations	4
3.2	Intrinsic Safety Parameters for FM (Factory Mutual)	4
3.3	Installation/Removal	5
4.0	SIGNAL INPUT CONNECTIONS (P3)	6
5.0	CONFIGURATION	7
5.1	Standard Setup	7
5.2	Field Configuration Chart	7
6.0	CUSTOMER CONFIGURATION AND CALIBRATION	9
6.1	Formula	9
6.2	Configuration Procedures	10
6.3	Calibration	10
6.4	Factory-Setup Label	10
7.0	WIRING DIAGRAM	11
ILLUSTRATIONS		
Figure 3-1	Exploded View	5
Figure 3-2	DIN Case Dimensions	6
Figure 5-1	Main Board Jumper Locations	8
Figure 7-1	Wiring Diagram for TX82B Usage for FM (Factory Mutual)	11

UNPACKING INSTRUCTIONS

Remove the Packing List and verify that you have received all equipment, including the following:

QTY	DESCRIPTION
1	Current Loop Meter Indicator with all applicable connectors attached.
1	Owner's Manual
1	Factory Setup Label

If you have any questions about the shipment, use the phone number for the Customer Service Department nearest you.

When you receive the shipment, inspect the container and equipment for signs of damage. Note any evidence of rough handling in transit. Immediately report any damage to the shipping agent.



Note

The carrier will not honor damage claims unless all shipping material is saved for inspection. After examining and removing contents, save packing material and carton in the event reshipment is necessary.

1.0 GENERAL INFORMATION

Model TX82B two-wire current-loop indicator accepts 1-5 mA, 4-20 mA, or 10-50 mA process signals and digitally displays the process variable in percentage or engineering units of such measurements as pressure, flow, temperature and level. No separate power supply or power connections are required, since the TX82B obtains operating power directly from the current loop with a voltage drop of less than 2.5 V. It can tolerate current overdrives up to 200 mA forward and 1000 mA reverse.

The compact TX82B circuit is mounted in a black polycarbonate case with the standard 1/8 DIN panel-mount bezel and a depth of less than 110 mm (4.33 in). Five 12.7 mm (0.5 in) high liquid crystal 7-segment digits are used to display ± 1999 active counts plus one or two dummy right-hand zeros.

The TX82B displays from -1999 to 1999 counts with the option of one or two dummy right-hand "0" digits. Zero suppression or elevation capability exceeds full scale. Program jumpers are used to scale the readout for percentage or engineering-unit display. Both zero and span are fine-tuned with multiturn potentiometers accessible through the display board, requiring lens removal for readjustment.

When removed from its case, the TX82B can be programmed with gas-tight jumpers for three input ranges (1-5, 4-20 or 10-50 mA), four coarse zero ranges, four decimal-point locations and the dummy right-hand zeros. Two additional jumpers are provided to reverse the span slope so that increasing the input can cause a reading decrease; thus a 4-20 mA input can be programmed to produce a 2000 to -18000 reading when one dummy right-hand zero is also used.

2.0 SPECIFICATIONS

2.1 INPUT

Current	1-5 mA, 4-20 mA or 10-50 mA
Protection	200 mA max forward and 1000 mA max reverse
Voltage Drop	2.5 V max forward and 1.2 V max reverse
Span Range	100 to 2000 counts continuous adjustment with a multiturn potentiometer
Zero Range	The multiturn zero potentiometer can displace the displayed reading by ± 500 counts from the center of each of the four overlapping zero ranges, provided that the resultant is within the ± 1999 count display capability.
Span Slope	Positive or Negative
Normal Mode Rejection at 50/60 Hz	46 dB minimum

2.2 ACCURACY AT 25°C

Maximum error	$\pm 0.1\% R \pm 1$ count
Zero tempco	± 0.1 ct/K typ, ± 0.3 ct/K max
Span tempco	$\pm 0.005\% S/K$ typ, $\pm 0.015\% S/K$ max

2.3 CONVERSION

Technique	Dual-slope, average value with autozero correction
Polarity	Determined automatically at the end of input integration period
Input integration period	100 milliseconds (nominal value)
Reading rate	2.5/second

2.4 DISPLAY

Type	7-segment LCD
Color	Black digits with white background
Symbols	-1.8.8.8.0.0, 12.7 mm (0.5 in) height
Polarity	Minus sign
Overrange	Three least-significant digits blank
Extra digits	One or two dummy right-hand zeros, jumper-selectable
Decimal points	Four positions, jumper-selectable
Lifetime (to 2:1 contrast ratio)	More than 30,000 hours
Temperature derating	2:1 for each 10°C above 60°C
Humidity derating	2:1 for each 10%RH above 60%RH

2.5 ENVIRONMENT

Standard operating temp	0 to 55°C
Extended operating temp option (conformally coated)	-40 to +85°C
Humidity	To 95% at 40°C
Bezel cover option	Splash-proof

2.6 MECHANICAL

Weight	170 g (6 oz)
Case material	Black polycarbonate, 94V-0 flammability rating
Case size	
Bezel (HxWxT)	48 x 96 x 7.67 mm
Depth behind bezel with mounting hardware	Less than 110 mm
Panel cutout (HxW)	45 x 92 mm
Electrical connections	3-terminal screw clamp connector
Wire size	0.13 mm ² - 2.5 mm ² (AWG 26-14)

3.0 MECHANICAL ASSEMBLY AND INSTALLATION

3.1 SAFETY CONSIDERATIONS

To ensure safe operation, follow the guidelines below:

VISUAL INSPECTION: Do not attempt to operate the instrument if damage is found.

SIGNAL WIRING: Insert the proper plus and minus signal wires into the plug-in screw-clamp connector terminals marked plus and minus. Ensure that the wires are securely clamped in the plug-in connector by rotating the screws in the plug-in connector clockwise but do not exceed a torque of .5 newton-meter (.37 pound-foot). Then plug the connector firmly into the socket located on the rear panel of the meter.

RAIN OR MOISTURE: Do not expose the instrument to condensing moisture.

3.2 INTRINSIC SAFETY PARAMETERS FOR FM (FACTORY MUTUAL)

Certificate No. 2Y4A4.AX

V max=12.5 V,

I max=250 mA

Intrinsically Safe for Class I, II and III, Division 1, Groups, A,B,C,D,E,F and G hazardous locations.

Ci=8.6 μ F

Li=0 mH

3.3 INSTALLATION/REMOVAL

The TX82B is housed in a 1/8 DIN case. The electronic circuitry can be installed or removed from the front and is attached to the case with two M4 screws through the rear panel.

Panel Mounting

1. Remove the two thumbnuts on the rear of the case.
2. Slide the sleeve off the case (see Figure 3-1 Exploded View).
3. Verify the panel cutout dimensions in Figure 3-2 Case Dimensions. Insert the case in the panel cutout from the front and slide the sleeve on from the rear. Install the two thumbnuts to secure the sleeve to the case.

Main Board Access:

1. Case must be removed from sleeve.
2. Remove lens from case.
3. Slide main board from front of case.

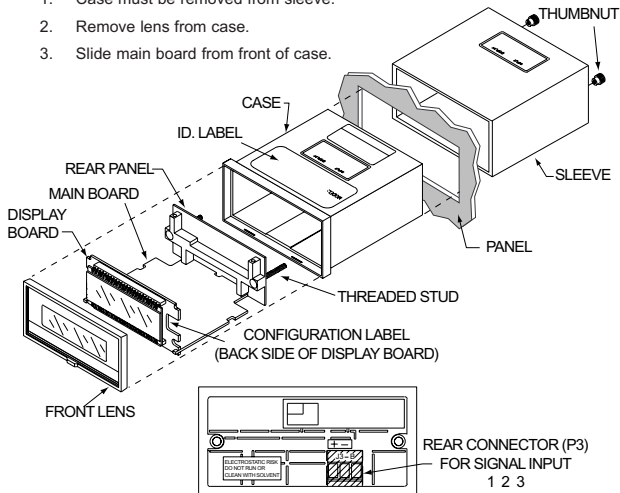
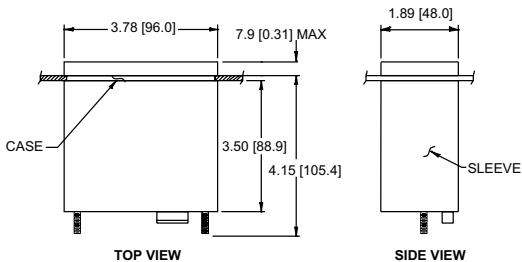
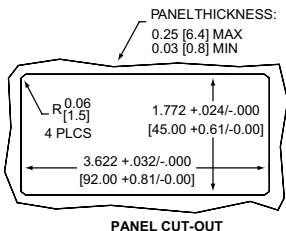

Figure 3-1 Exploded View (includes rear panel)



TOP VIEW

SIDE VIEW



PANEL CUT-OUT

NOTES: DIMENSIONS ARE IN INCHES [MILLIMETERS].

Figure 3-2. DIN Case Dimensions

4.0 SIGNAL INPUT CONNECTIONS (P3)

The signal input connections for all meters are made at connector P3 as follows (see Figure 3-1):

P3 Connection	Signal
1	Signal Hi
2	Signal Lo
3	No Connection

5.0 CONFIGURATION

The standard TX82B meter is factory-configured for an input of 4-20 mA to display 00.0 to 100.0. Field configuration for input current range, decimal point location, dummy right-hand zero digit, coarse zero range selection, and reverse span slope may be done by relocating internal push-on jumpers and adjusting the span and zero potentiometers. Refer to Figure 5-1 for the span and zero potentiometers and internal jumper locations.

5.1 STANDARD SETUP

Unless the customized configuration option is specified, jumpers are factory-installed at S1-H, S2-C, S1-B, S1-C and the unit is calibrated for 4-20 mA = 00.0 to 100.0.

5.2 FIELD CONFIGURATION CHART

CONFIGURATION	JUMPER INSTALLATION
1.5 mA Input	None
*4-20 mA Input	S1-H
10-50 mA Input	S1-J
*Normal Span Slope	S1-B, S1-C
Reverse Span Slope	S1-A, S1-D
Decimal Point 1.999 (DP1)	S2-E
Decimal Point 19.99 (DP2)	S2-D
*Decimal Point 199.9 (DP3)	S2-C
Decimal Point 1999. (DP4)	S2-B
Decimal Point 19990. (DP5)	S2-F
Dummy Right-Hand Zero (DRHZ)	S2-A
Dummy Right-Hand Zeroes (2DRHZ)	S2-G, S2-H, S2-J, S2-A
Zero Range -2510 to -1420 (ZR1)	S1-G
Zero Range -1580 to -420 (ZR2)	S1-F
*Zero Range -470 to +850 (ZR3)	None
Zero Range +760 to +2000 (ZR4)	S1-E

*Standard factory setup

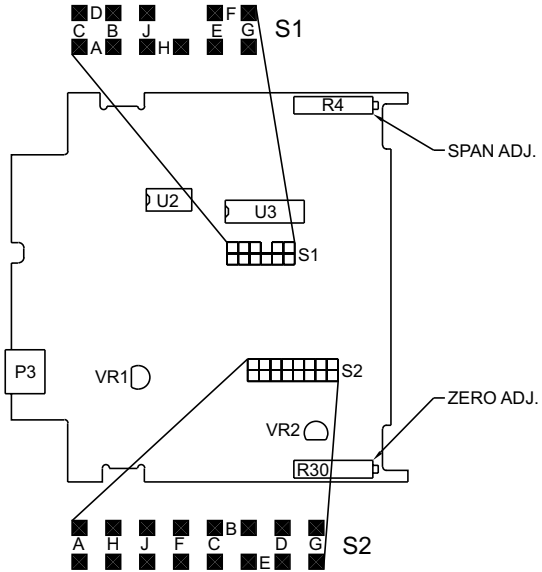

Figure 5-1 Main Board Jumper Locations

6.0 CUSTOMER CONFIGURATION AND CALIBRATION

Use this procedure to determine the configuration of the TX82B customized setup. The procedure is general; customers can specify any two current inputs and their corresponding digital readings. Pin-groups are shown in Figure 5-1.

6.1 FORMULA

Base all your calculations on either the 1-5, 4-20 or 10-50 mA range.

1. Determine the lowest input current, I1, which is specified by the customer:

$$I1 = \text{_____ mA}$$

2. Determine the highest input current, I2, which is specified by the customer:

$$I2 = \text{_____ mA}$$

3. Determine the reading, N1, at input current I1, which is specified by the customer.

$$N1 = \text{_____ counts}$$

4. Determine the reading, N2, at input current I2, which is specified by the customer:

$$N2 = \text{_____ counts}$$

5. Calculate the Gain, G1:

$$G1 = \frac{(N2 - N1)}{(I2 - I1)} = \text{_____ counts per mA}$$

(If G1 is greater than 125, it is out of range for a standard unit.)

6. Calculate the Required Zero Range number, RZR:

$$RZR = N1 - (I1 \times G1) = \text{_____}$$

7. Select the Zero Range required from the following chart where the Required Zero Range number falls between the upper and lower limits of that range:

$$ZR1 = -2510 \text{ to } -1420$$

$$ZR2 = -1580 \text{ to } -420$$

$$ZR3 = -470 \text{ to } +850$$

$$ZR4 = +760 \text{ to } +2000$$

$$ZR = \text{_____}$$

6.2 CONFIGURATION PROCEDURES

1. Remove all push-on jumpers.
2. For an input current range of 1-5 mA, no jumper is required.
For 4-20 mA input, install a push-on jumper at S1-H.
For 10-50 mA input, install a push-on jumper at S1-J.
3. If N2 (Section 6.1) is less than N1, reverse the signal polarity by removing jumpers from S1-B and S1-C and reinstalling jumpers at S1-A and S1-D.
4. Select the zero range required (ZR1-4) and install the push-on jumper as indicated in the configuration chart (Section 5.2).
5. If a decimal point is required (DP1-5), install a push-on jumper as indicated in the configuration chart (Section 5.2).
6. If one dummy right-hand zero is required, install jumper at S2-A.
7. If two dummy right-hand zeros are required, install jumpers at S2-A, S2-G, S2-H, and S2-J.

6.3 CALIBRATION

1. Apply an input current (I1) and adjust the zero pot (Z) to read N1.
2. Apply an input current (I2) and adjust the span pot (S) to read N2.
3. Repeat steps 1 and 2 as required to set N1 and N2 to within ± 1 count.

6.4 FACTORY-SETUP LABEL

The label on the meter shows the factory-configured input and display settings. If the configuration is changed, use the extra label included with the meter to indicate the new settings.

7.0 WIRING DIAGRAM

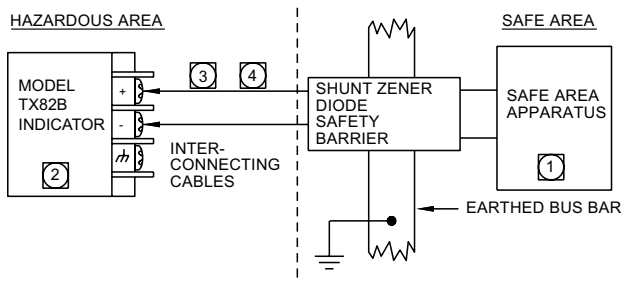

NOTES:

- 1 Apparatus which is unspecified except that it must not be supplied from nor contain under normal or abnormal conditions a source of potential with respect to Earth in excess of 250V R.M.S. or 250V D.C.
- 2 The following output parameters apply; $V_{max}=12.5V$, $I_{max}=250mA$, $C_i=8.6\mu F$, $L_i=0mH$
- 3 The Interconnecting Cable may be a twin pair, or a pair contained in a type A or type B multicore cable provided that the peak voltage of any circuit contained within the multicore does not exceed 60 volts.
- 4 The capacitance or inductance or inductance to resistance ($4/R$) ratio of the Interconnecting Cable must not exceed the values specified for the barrier in use.
- 5 The electrical circuit in the Hazardous Area must be capable of withstanding without breakdown an A.C. test voltage of 500V R.M.S. to Earth or frame for one minute.

Figure 7-1 Wiring Diagram for TX82B Usage for FM (Factory Mutual)

WARRANTY/DISCLAIMER

OMEGA ENGINEERING, INC. warrants this unit to be free of defects in materials and workmanship for a period of **13 months** from date of purchase. OMEGA's Warranty adds an additional one (1) month grace period to the normal **one (1) year product warranty** to cover handling and shipping time. This ensures that OMEGA's customers receive maximum coverage on each product.

If the unit malfunctions, it must be returned to the factory for evaluation. OMEGA's Customer Service Department will issue an Authorized Return (AR) number immediately upon phone or written request. Upon examination by OMEGA, if the unit is found to be defective, it will be repaired or replaced at no charge. OMEGA's WARRANTY does not apply to defects resulting from any action of the purchaser, including but not limited to mishandling, improper interfacing, operation outside of design limits, improper repair, or unauthorized modification. This WARRANTY is VOID if the unit shows evidence of having been tampered with or shows evidence of having been damaged as a result of excessive corrosion; or current, heat, moisture or vibration; improper specification; misapplication; misuse or other operating conditions outside of OMEGA's control. Components in which wear is not warranted, include but are not limited to contact points, fuses, and triacs.

OMEGA is pleased to offer suggestions on the use of its various products. However, OMEGA neither assumes responsibility for any omissions or errors nor assumes liability for any damages that result from the use of its products in accordance with information provided by OMEGA, either verbal or written. OMEGA warrants only that the parts manufactured by the company will be as specified and free of defects. OMEGA MAKES NO OTHER WARRANTIES OR REPRESENTATIONS OF ANY KIND WHATSOEVER, EXPRESSED OR IMPLIED, EXCEPT THAT OF TITLE, AND ALL IMPLIED WARRANTIES INCLUDING ANY WARRANTY OF MERCHANTABILITY AND FITNESS FOR A PARTICULAR PURPOSE ARE HEREBY DISCLAIMED. LIMITATION OF LIABILITY: The remedies of purchaser set forth herein are exclusive, and the total liability of OMEGA with respect to this order, whether based on contract, warranty, negligence, indemnification, strict liability or otherwise, shall not exceed the purchase price of the component upon which liability is based. In no event shall OMEGA be liable for consequential, incidental or special damages.

CONDITIONS: Equipment sold by OMEGA is not intended to be used, nor shall it be used: (1) as a "Basic Component" under 10 CFR 21 (NRC), used in or with any nuclear installation or activity; or (2) in medical applications or used on humans. Should any Product(s) be used in or with any nuclear installation or activity, medical application, used on humans, or misused in any way, OMEGA assumes no responsibility as set forth in our basic WARRANTY/DISCLAIMER language, and, additionally, purchaser will indemnify OMEGA and hold OMEGA harmless from any liability or damage whatsoever arising out of the use of the Product(s) in such a manner.

RETURN REQUESTS/INQUIRIES

Direct all warranty and repair requests/inquiries to the OMEGA Customer Service Department. **BEFORE RETURNING ANY PRODUCT(S) TO OMEGA, PURCHASER MUST OBTAIN AN AUTHORIZED RETURN (AR) NUMBER FROM OMEGA'S CUSTOMER SERVICE DEPARTMENT (IN ORDER TO AVOID PROCESSING DELAYS).** The assigned AR number should then be marked on the outside of the return package and on any correspondence. The purchaser is responsible for shipping charges, freight, insurance and proper packaging to prevent breakage in transit.

FOR **WARRANTY** RETURNS, please have the following information available BEFORE contacting OMEGA:

1. Purchase Order number under which the product was PURCHASED,
2. Model and serial number of the product under warranty, and
3. Repair instructions and/or specific problems relative to the product.

FOR **NON-WARRANTY** REPAIRS, consult OMEGA for current repair charges. Have the following information available BEFORE contacting OMEGA:

1. Purchase Order number to cover the COST of the repair,
2. Model and serial number of the product, and
3. Repair instructions and/or specific problems relative to the product.

OMEGA's policy is to make running changes, not model changes, whenever an improvement is possible. This affords our customers the latest in technology and engineering.

OMEGA is a trademark of OMEGA ENGINEERING, INC.

© Copyright 2018 OMEGA ENGINEERING, INC. All rights reserved. This document may not be copied, photocopied, reproduced, translated, or reduced to any electronic medium or machine-readable form, in whole or in part, without the prior written consent of OMEGA ENGINEERING, INC.

Where Do I Find Everything I Need for Process Measurement and Control? **OMEGA...Of Course!**

Shop online at omega.com

TEMPERATURE

- ☑ Thermocouple, RTD & Thermistor Probes, Connectors, Panels & Assemblies
- ☑ Wire: Thermocouple, RTD & Thermistor
- ☑ Calibrators & Ice Point References
- ☑ Recorders, Controllers & Process Monitors
- ☑ Infrared Pyrometers

PRESSURE, STRAIN AND FORCE

- ☑ Transducers & Strain Gages
- ☑ Load Cells & Pressure Gages
- ☑ Displacement Transducers
- ☑ Instrumentation & Accessories

FLOW/LEVEL

- ☑ Rotameters, Gas Mass Flowmeters & Flow Computers
- ☑ Air Velocity Indicators
- ☑ Turbine/Paddlewheel Systems
- ☑ Totalizers & Batch Controllers

pH/CONDUCTIVITY

- ☑ pH Electrodes, Testers & Accessories
- ☑ Benchtop/Laboratory Meters
- ☑ Controllers, Calibrators, Simulators & Pumps
- ☑ Industrial pH & Conductivity Equipment

DATA ACQUISITION

- ☑ Communications-Based Acquisition Systems
- ☑ Data Logging Systems
- ☑ Wireless Sensors, Transmitters, & Receivers
- ☑ Signal Conditioners
- ☑ Data Acquisition Software

HEATERS

- ☑ Heating Cable
- ☑ Cartridge & Strip Heaters
- ☑ Immersion & Band Heaters
- ☑ Flexible Heaters
- ☑ Laboratory Heaters

ENVIRONMENTAL MONITORING AND CONTROL

- ☑ Metering & Control Instrumentation
- ☑ Refractometers
- ☑ Pumps & Tubing
- ☑ Air, Soil & Water Monitors
- ☑ Industrial Water & Wastewater Treatment
- ☑ pH, Conductivity & Dissolved Oxygen Instruments