

PHCN-370/380 Series

pH Controllers/Recorders

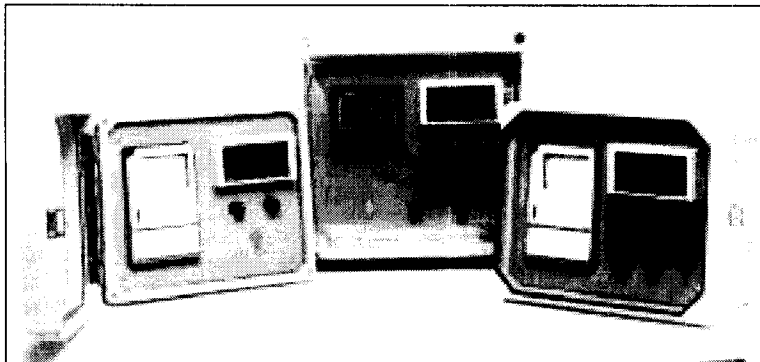

Ω OMEGA[®] Operator's Manual



Servicing USA and Canada: Call OMEGA Toll Free

USA

One Omega Drive, Box 4047
Stamford, CT 06907-0047
Telephone: (203) 359-1660
FAX: (203) 359-7700

Canada

976 Bergar
Laval (Quebec) H7L 5A1
Telephone: (514) 856-6928
FAX: (514) 856-6886

Sales Service: 1-800-826-6342 / 1-800-TC-OMEGA™
Customer Service: 1-800-622-2378 / 1-800-622-BEST™
Engineering Service: 1-800-872-9436 / 1-800-USA-WHEN™
TELEX: 996404 EASYLINK: 62968934 CABLE: OMEGA

Servicing Europe: United Kingdom Sales and Distribution Center

25 Swannington Road, Broughton Astley, Leicestershire
LE9 6TU, England
Telephone: 44 (1455) 285520 FAX: 44 (1455) 283912

The OMEGA Complete Measurement and Control Handbooks & Encyclopedias

- ✓ Temperature
- ✓ Pressure, Strain & Force
- ✓ Flow and Level
- ✓ pH and Conductivity
- ✓ Data Acquisition Systems
- ✓ Electric Heaters
- ✓ Environmental Monitoring and Control



Call for Your FREE Handbook Request Form Today: (203) 359-RUSH

CJS0695FMSBA

Unpacking Instructions

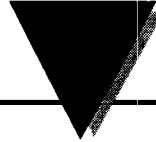

Remove the Packing List and verify that you have received all equipment, including the following (quantities in parentheses):

PHCN-370 Series Unit (1)

NEMA-4X enclosure (1)

Roll of 30 day chart paper **shipped with the recorder only** (1)

Operator's Manual (1)

If you have any questions about the shipment, please call the OMEGA Customer Service Department.

When you receive the shipment, inspect the container and equipment for signs of damage. Note any evidence of rough handling in transit. Immediately report any damage to the shipping agent.



The carrier will not honor damage claims unless all shipping material is saved for inspection. After examining and removing contents, save packing material and carton in the event reshipment is necessary.

Chapter 1 Introduction	1-1
1.1 General Description	1-1
1.2 Features	1-2
1.3 Available Models	1-2
1.4 Optional Ranges	1-2
Chapter 2 Installation	2-1
2.1 pH Electrode Considerations	2-1
2.2 Mounting	2-2
2.3 Wiring	2-2
2.3.1 Wiring for PHCN-50	2-2
2.3.2 Wiring for PHCN-51 and PHCN-52	2-4
2.3.3 Wiring for PHCN-53	2-7
2.3.4 Wiring for PHCN-54	2-9
2.4 Wiring to the Remote Display	2-11
2.5 Chart Recorder Paper Installation	2-12
Chapter 3 Operating the Controller/Recorder	3-1
3.1 Controls and Indicators	3-1
3.1.1 PHCN-370	3-2
3.1.2 PHCN-371	3-2
3.1.3 PHCN-372	3-3
3.2 Operating Procedure	3-4
3.2.1 Standardizing the Probe using the Transmitter	3-4
3.2.2 Adjusting the Deadband (PHCN-51, 52, 53, 54)	3-5
3.2.3 Timer Adjustment	3-5
Chapter 4 Troubleshooting	4-1
4.1 Troubleshooting Guide	4-1
4.2 Inductive Loads	4-4
Chapter 5 Specifications	5-1
Chapter 6 Accessories	6-1
6.1 Replacement Accessories	6-1

Introduction

1.1 General Description

The OMEGA® PHCN-370/380 Series of pH, Conductivity or ORP Controllers and Recorders provides a versatile and economical means of measuring, controlling, and recording pH levels of waste water, pools, chemical process streams, and other effluent conditions common to the industrial sector. The extensive list of standard features of this Microprocessor-Based Controller include a LED display for the measured pH value, or mV coming from the pH sensor to conveniently check sensor offset and temperature in °C measured by the ATC sensor PT100 ohms. For ease of operation, all calibration and parameter setpoints are selectable through the front keypad.

Depending on your specific application, you can choose from several configurations: recorder only; controller only; recorder/controller combination; recorder/dual controller/recorder. Units are housed in a standard NEMA-4X enclosure. The standard pH input range is 0 to 14. A 0 to 2000mV scale is used in conjunction with an ORP electrode for chrome reduction or cyanide destruction. The controller is intended to turn power on or off to pump whenever the pH of the solution being monitored exceeds a set limit. Power outputs are available to turn on with either increasing or decreasing pH. The master on/off power switch is located on the front panel. The 6 amp fuse is for pumps and alarm; the 1/2 amp fuse is for the rest.

1 Introduction

1.2 Features

- Measures, Controls and Records pH
- Range of 0 to 14 pH
- NEMA-4X Wall Mount Enclosure Standard
- Optional ORP Controller or Conductivity

1.3 Available Models

Part Number	Description
PHCN-370	pH recorder accepts pH electrode directly
PHCN-371	Single input pH controller
PHCN-372	Single input pH controller/recorder
PHCN-53	Dual input pH controller/recorder
PHCN-54	Dual input pH controller
PHCN-55	Battery powered pH recorder

1.4 Optional Ranges

Part Number	Description
-ORP	ORP controller; 0 to 1000mV range
-14	0 to 14 pH display range

2 Installation

2.1 pH Electrode Considerations

The pH electrode is the most sensitive and crucial part of the system, as the PHCN-370 relies on a correct input from the electrode. Important factors to consider before installation are:

- Electrode location — The pH electrode should always be mounted in a vertical position near but downstream from where the reagent will be added. This location should be representative of the whole process solution. The electrode must remain wet at all times. (Ensure proper mixing of the process solution).
- Maintenance — To ensure the validity of the pH input, the electrode must be cleaned and calibrated periodically. In every application, the pH electrode may become coated with the process residue. Each time the electrode is cleaned or replaced, it must be recalibrated to the PHCN-370 Series.
- The glass may also be attacked by high alkaline solutions (particularly at high temperatures) which damage the glass or cause sodium ion error. Very acidic solutions which contain fluorides may dissolve the glass membrane. Consult OMEGA Sales Department for special electrodes.
- Temperature not only affects the pH measurement, but also the normal life expectancy of the pH electrode. Maximum life is achieved at ambient temperatures, although special electrodes are available that are more durable at higher temperatures.
- Chemical composition of the process solution may not only affect the glass pH electrode, but also the assembly housing. In these cases, Kynar or stainless steel housings may be required.

- Stray currents in the solution will cause the pH electrode to report incorrect information to the PHCN-370. The output from the pH electrode is only a few millivolts. If stray currents are present, they may be picked up by the pH electrode and transmitted to the controller. It is necessary to eliminate the current either by finding the leakage or by adding a ground to the solution.

2.2 Mounting

The PHCN-370 NEMA-4X enclosure can be mounted to any flat surface through the 4 mounting holes in its base.

2.3 Wiring

The front panels are factory prewired from the controller and recorder to the switch and fuses. It is necessary to wire input power; output to the pumps; and input from the pH, ORP or Conductivity and temperature electrodes, where applicable.

2.3.1 Wiring for PHCN-370 (Refer to Figure 2-1)

1. Pull the wires through the side of the NEMA-4X enclosure.
2. Turn on heat power to the terminal strip inside Nema box.
3. Connect pH input and temperature electrode, where applicable on the back of panel.
4. Fasten the panel in place and you are now ready to turn the power ON.

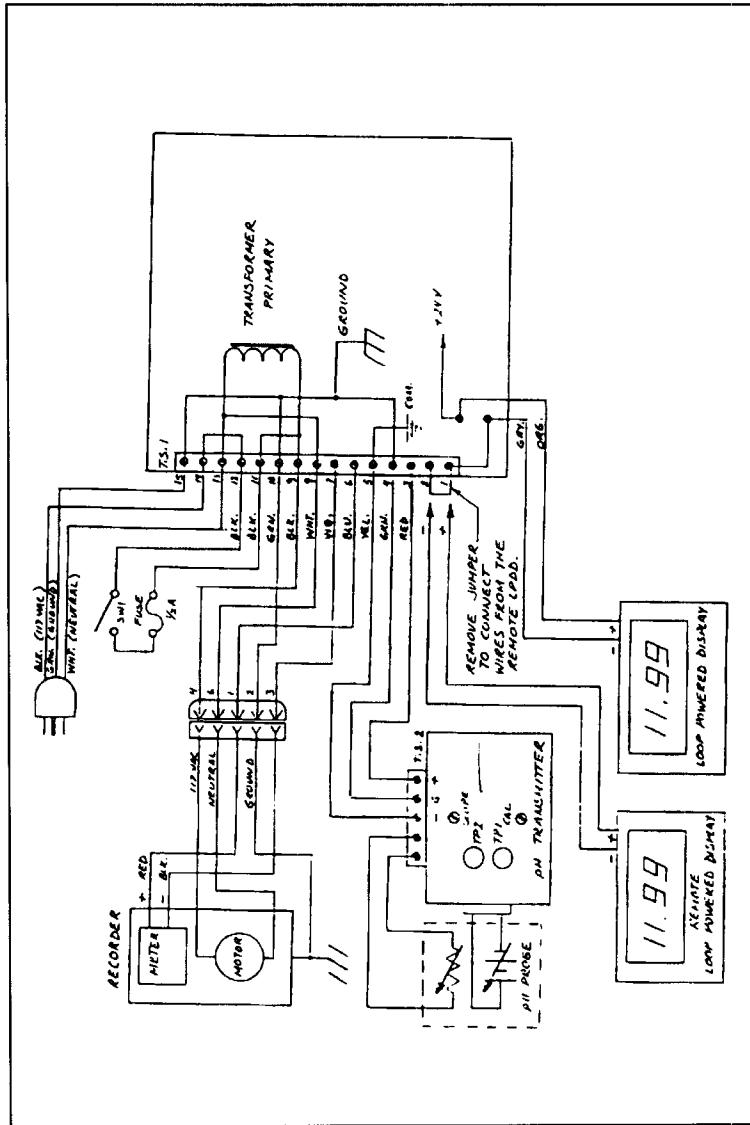

Figure 2-1. Wiring Diagram (PHCH-370)

2.3.2 Wiring for PHCN-371

For PHCN-371, see Figure 2-2.

1. Pull the wires through the side of the NEMA-4X enclosure.
2. Connect power to the terminal strip inside Nema box
3. Connect the pumps to the terminal strip inside Nema box.
4. Connect pH input to the BNC connector and temperature electrode where applicable on the back of panel.
5. Fasten the panel in place and you are now ready to turn the power ON and setup the unit.

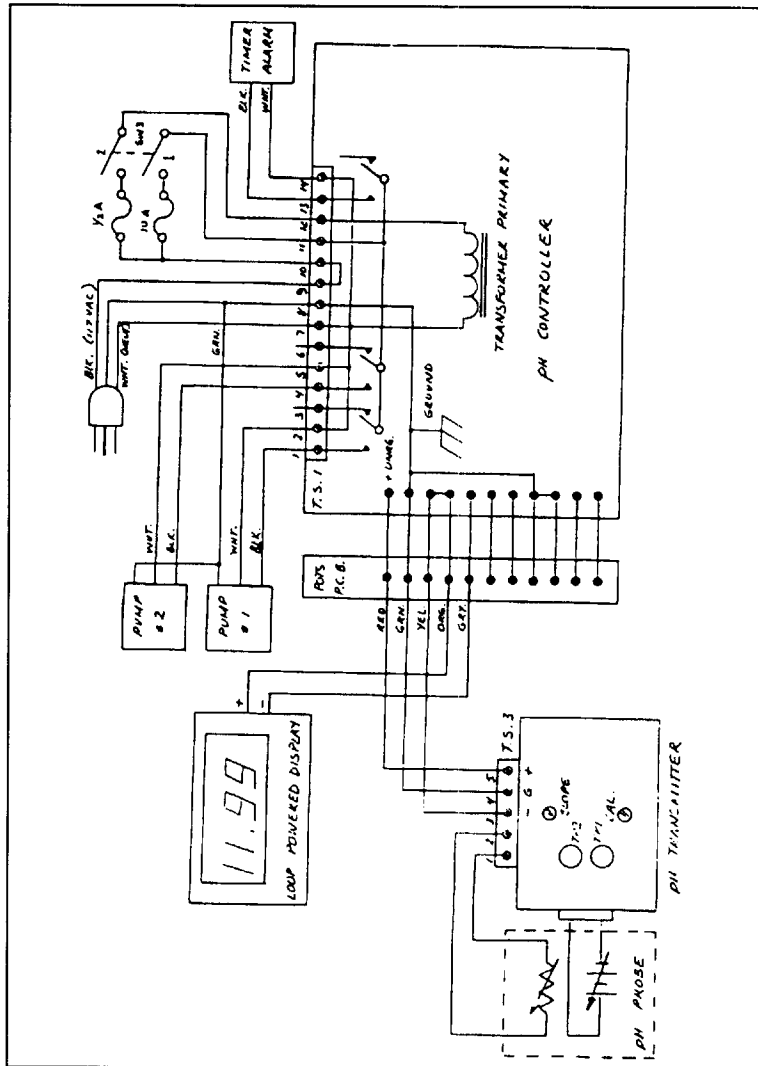

Figure 2-2. Wiring Diagram (PHCN-371)

2 Installation

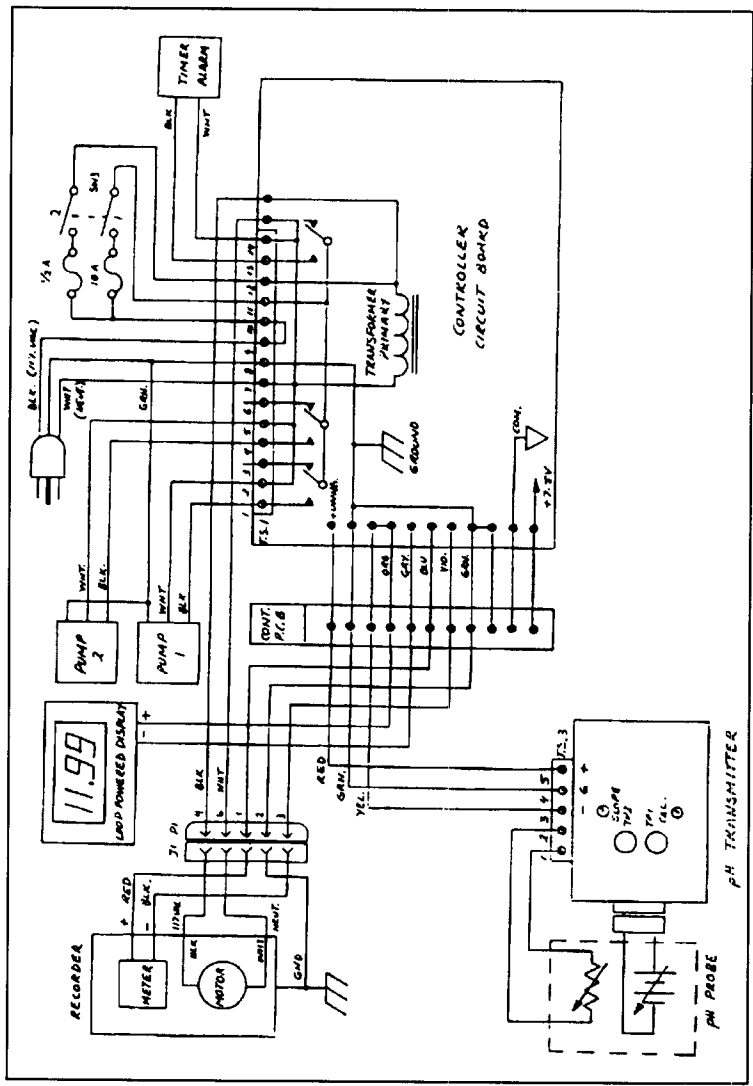

Figure 2-3. Wiring Diagram (PHCN-372)

2.4 Chart Recorder Paper Installation

Refer to Figure 2-4. A warning to “renew chart” appears on the last three feet of each roll of paper. To install:

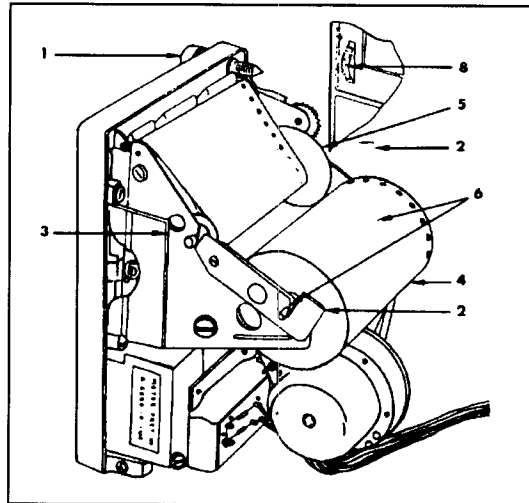

Figure 2-4. Installing the Chart Paper

1. Turn power off before loading chart paper.
2. Open recorder by loosening thumb screw (1) and lowering the recorder assembly.
3. Unlatch retaining clips (2).
4. Open panel to chassis latch (3) on side plate.
5. Remove supply and take-up roller. If paper is still attached to the supply roller, carefully slide the paper from between the front panel and chart drive. Do not pull the paper backward through the recorder because of the danger of snagging the pointer.
6. Insert the supply roller into the new roll of chart paper. The perforated end of the paper is nearest to the roller shoulder.

7. Unroll about a foot of paper. Slide the paper between the panel and side plate, sprocket holes first. Keep the paper taut and close to the drive drum to prevent snagging the pointer.
8. Engage the supply roller shaft in both seating notches (6) and check to be sure that the paper sprocket holes engage the time drum sprockets.
9. Slide the cardboard sleeve all the way on the take-up roller against the disc.
10. Butt the paper against the disc and tape the paper to the sleeve, printed side out. Wrap a few turns of the paper to be sure paper is started true.
11. Continue rolling paper and place roller shaft into notches. (Lower notch left-hand side).
12. Close clips (2), latch (3) and recorder front panel; tighten thumb screw (1).
13. Advance paper with the chart advance wheel (8) to assure that the paper moves through the recorder. Set to time.



Operating the Controller/Recorder

3.1 Operating PHCN-370

The following describes how to calibrate and configure your PHCN-370 indicator

The PHCN-370 has its input set up to read 4-20mA current, in order to calibrate the unit follow these steps:

3.1.1 Insert your PH sensor in a 4.00 PH buffer solution

1. Press the MENU button until the meter reads "ScAL".
2. Press the /TARA button until the meter shows "LivE".
3. Press the /MAX button. The meter momentarily flashes "rd1".
4. Change the meter reading to read 0400 using the /MAX and /TARE buttons.
5. Press MENU to accept the 400 value. Then meter momentarily flashes "rd2".

3.1.2 Now insert your PH sensor in a 7.00 PH buffer solution

6. Change the meter reading to 0700 using the /MAX and /TARE buttons.
7. Press MENU button to save the changes and return to display the active PH value.

Refer to page 14, section 4.2, to set the decimal point in the middle position ("FF.FF").

Refer to page 7, section 3.1, and remove the S2 jumper to prevent unauthorized changes to the calibration.

3.1.3 PHCN-52

The PHCN-52 has the same operating controls and indicators as the PHCN-51, with the following additions:

1. A recorder front panel calibration adjustment is used to set the recorder at 7.0 pH when the probe is in a 7.0 buffer.
2. A strip chart recorder that is driven by the circuitry in the controller. It indicates and records from 2 to 12 pH. Chart speed is 1 inch per hour. One roll of chart paper is included and will last an estimated 30 days.

3.1.4 PHCN-53

The PHCN-53 has the same operating controls and indicators as the PHCN-52, with the following differences:

The transmitter is mounted on the recorder chassis. It is powered from the controller and has separate pH, ORP and temperature probes for its input. It has a screwdriver "Slope" adjustment and a "Cal" adjustment on the recorder panel to set the recorder to 7.0 pH when the recorder probe is in a 7.0 buffer. For remote mounting, the "Cal" adjustment is on the adapter attached to the transmitter. The adapter board has a pair of test points to monitor when standardizing the recorder probe.

3.1.5 PHCN-54

The PHCN-54 is the same as the PHCN-51, except that there are two separate controllers.

The ORP Control Option has the following differences in control and indicator operations:

1. The front panel digital switches are settable from 0 to 99% of full scale in 1% increments (10 mV per increment for 0 to +1000 mV).
2. The front panel digital display provides readouts from 000 to 1000 mV.

3.2 Operating Procedure

1. Make sure electrodes are connected.
2. Turn on the power switch.
3. Set set point #1 to control Pump 1 (set A-B for acid or base).
4. Set set point #2.
5. Adjust deadband for each set point.
6. Adjust time delay to desired setting or disengage if not used.
7. Switch "STBY" to "RUN" mode and begin normal operation.

3.2.1 Standardizing the Probe Using the Transmitter

The transmitter has a pair of test points to monitor the loop current for remote installation. Connect a 3-1/2 digit voltmeter to test points on the transmitter. Place the probe in a 7.0 buffer solution and adjust the "Cal" potentiometer for the 7.0 voltage on the label of the transmitter. If the operating range is below 7 pH, place the probe in a 4.0 buffer and adjust the "Slope" potentiometer. Repeat these adjustments until both are correct, because there is some interaction between "Slope" and "Cal".

3.2.2 Setting Control Limits (PHCN-51, PHCN-52, PHCN-53, PHCN-54)

The control limit digit switches provide readouts directly in pH units from 2.0 to 11.9 pH. To set the limit for pump #1, adjust the upper set point switch. Pump #2 is adjusted with the lower set point switch. If the upper limit (pump #1) is to control acid addition, set the slide switch nearest the top of the panel on the controller circuit board to position "A"; if it is to control base addition, set the switch to position "B". The acid/base slide switch for the lower limit (Pump #2) is located near the center of the controller circuit board.

If the controller uses the ORP option, the set point switches are in percent of span, i.e. 0 to 99%.

3.2.3 Adjusting the Deadband (PHCN-51, PHCN-52, PHCN-53, PHCN-54)

The deadband adjustment potentiometers for the set points are located next to the digit switch, and are adjustable from approximately 1 to 50% of span. If a deadband of 1 pH unit is required, set the potentiometer to 10%. This means that the set point will energize when the pH level goes above it (slide switch set for Acid), and will de-energize 1 pH unit less than the set point. The opposite will happen if the slide switch is in the Base position.

3.2.4 Timer Adjustment

The timer adjustment is continuous from 1 minute to 11 minutes from the front panel. Set the potentiometer to the maximum time it should take to correct the pH level.



Operating the Controller/Recorder

Notes

4

Troubleshooting

4.1 Troubleshooting Guide

Symptom	Possible Cause	Solution
No reading on digital display	No power to unit	Check input wiring
	Blown fuse	Replace fuse
	Loop wiring open	Check loop wiring between transmitter and display
	Defective transmitter	Return unit to factory
	Transmitter wires reversed	Return unit to factory
Reading on display is high or low	Out of calibration	Recalibrate
	Bad probe	Change probe
	Defective transmitter	Replace transmitter or return to factory
	Stray currents	See Section 2.1
Reading on display is negative	Display out of calibration	Return to factory
	Defective transmitter	Return to factory
	Display wires reversed	Return to factory
Reading on display is over range	Display out of calibration	Return to factory
	Defective transmitter	Return to factory
Reading high in 10 buffer or low in 4 buffer	100Ω temperature sensor instead of 1000Ω	Replace with correct temperature sensor

Symptom	Possible Cause	Solution
Set point indicators will not turn on	Time delay has actuated	Reset time delay by turning front panel power switch off and on OR Disable time delay with time delay switch
	Standby switch not in "RUN" mode	Put standby switch in "RUN" mode
	Defective controller	Return to factory
Set point indicators will not turn off	Defective controller	Return to factory
Display readings unstable	Stray currents	See Section 2.1
	Defective probe	Replace probe
	Defective transmitter	Return to factory
	Temperature sensor open or loose connection	Check wires, replace probe or temperature element
	No fixed temperature compensation resistor or loose connection	Tighten connections or install resistor
	Defective controller	Return to factory
Unit calibrates in buffer solutions, but does not read correctly in process effluent	Stray currents	See Section 2.1
Display has extra segments or decimal points	Moisture and contaminants on display circuit board	Place unit in dry heat oven at 120°F for 1/2 hour
	Humid or contaminated environment	Use NEMA-4X enclosure

Symptom	Possible Cause	Solution
Unit will not calibrate in buffer solution	Defective probe	Replace probe
	Protective cap on electrode	Remove cap
	Open temperature sensor or loose wires	Check wires, replace probe or temperature element
	No fixed temperature compensation resistor or loose connection	Tighten connections or install resistor
	Probe not in solution	Put probe in solution
	Electrode bulb has dried out	Soak probe in 5% HCl for five minutes then soak one to two hours in KCl
One or both set point indicators operate in the reverse mode	A/B switches in wrong position	Put switch in correct position
One or both relays operate in the reverse mode	Load wired to incorrect relay contact	Wire to N.O. relay contact
Set point indicator turns on but relay does not actuate OR Set point indicators turn off but relay stays on	Defective controller	Return to factory
Relay chatter	Noise generated by inductive load	Required damping network across load, see Section 4.2
	Deadband too small	Increase deadband adjustment
	Power line fluctuating	Provide adequate power for controller

Symptom	Possible Cause	Solution
Blows fuse when set point actuates	Load fuse too small or fuses reversed	Check fuses
	Load current too high	Check load

4.2 Inductive Loads

The relays in the controllers are rated at 10A at 120Vac for resistive loads. The rating for inductive loads is 3A with a power factor of 0.4 at 120Vac. Inductive loads will cause arcing at the contacts and usually make the contacts fail and the relay remains on all the time. Since this power factor is difficult to determine, it is a good idea to install a damping network across the load to absorb some of inductive effects of the load. The damping network consists of a $0.1\mu\text{F}$ capacitor @ 600V rating in series with a $1\text{K}\Omega$ (2W minimum) resistor. Connect it as shown in Figure 4-1. This will prolong the life of the contacts and reduce electrical noise generated when the contacts open or close. Note: Relays require a minimum load of 200 mA.

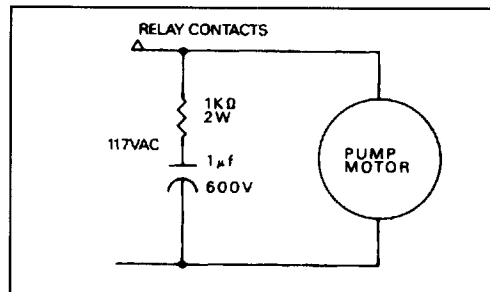

Figure 4-1. Relay Contacts

5 Specifications

Recorder

Display:	None
Range:	2 to 12 pH
Resolution:	0.2 pH/lateral chart deviation
Accuracy:	±0.2 pH
Repeatability:	±0.2 pH
Temperature Compensation:	Manual supplied with 1093Ω resistor; Automatic 1000Ω platinum RTD
Response Time:	1 second
Chart Speed:	1 inch per hour
Power Requirements:	120Vac 50/60 Hz

pH Controller

Display:	1/2" (12.7mm); 3-1/2 digit LCD
Range:	2 to 12 pH
Resolution:	0.1 pH
Accuracy:	±0.02 pH
Repeatability:	±0.02 pH
Temperature Compensation:	Manual supplied with 1093Ω resistor; Automatic 1000Ω platinum RTD
Power Requirements:	120Vac 50/60 Hz (230Vac optional)
Contact:	Two, 6A SSR, requires 200mA minimum load
Deadband Adjustment:	0% to 50% of setpoint
Safety Time Delay:	Adjustable, 1 to 11 minutes
Time Delay Relay:	6 amp SPDT
Temperature:	K-79-7 six inch stem pocket thermometer range of -10 to 110°C



Specifications

Optional ORP Controller

Display:	0.5" (12.7 mm), 3-1/2 digit LCD
Range:	0 to 1000mV
Resolution:	1mV
Accuracy:	±1mV
Repeatability:	±1mV
Power Requirements:	120Vac 50/60 Hz
Contact:	Two, 6A SSR, requires 200mA minimum load
Deadband Adjustment:	0% to 50% of setpoint
Safety Time Delay:	Adjustable, 1 to 11 minutes
Time Delay Relay:	6 amp SPST
Weight for all units except PHCN-55:	approx. 10 pounds (4.5 kg)
Weight (PHCN-55):	approx 16 pounds (7.3 kg)
Dimensions (H x W x D):	11.25" x 9.25" x 5.50" (285.75 x 234.95 x 139.7 mm)

Table 5-1. Resistor Values

TEMP	0°C	25°C	40°C	50°C	70°C	90°C	100°C
R _{tc} (Ω)	1000.0	1094.9	1151.4	1189.0	1263.8	1338.0	1375.0
pH	mV	mV	mV	mV	mV	mV	mV
0	+379.3	+414.0	+434.9	+448.8	+476.6	+504.4	+518.2
1	+325.1	+354.9	+372.8	+384.7	+408.5	+432.3	+444.2
2	+270.1	+295.8	+310.7	+320.6	+340.5	+360.3	+370.2
3	+216.8	+236.6	+248.5	+256.5	+272.4	+288.2	+296.1
4	+162.6	+177.5	+186.4	+192.4	+204.3	+216.2	+222.1
5	+108.4	+118.3	+124.2	+128.2	+136.2	+144.1	+148.1
6	+54.19	+59.15	+62.13	+64.12	+68.09	+72.05	+74.03
7	0	0	0	0	0	0	0
8	-54.19	-59.15	-62.13	-64.12	-68.09	-72.05	-74.03
9	-108.4	-118.3	-124.2	-128.2	-136.2	-144.1	-148.1
10	-162.6	-177.5	-186.4	-192.4	-204.3	-216.2	-222.1
11	-216.8	-236.6	-248.5	-256.5	-272.4	-288.2	-296.1
12	-270.1	-295.8	-310.7	-320.6	-340.5	-360.3	-370.2
13	-325.1	-354.9	-372.8	-384.7	-408.5	-432.3	-444.2
14	-379.3	-414.0	-434.9	-448.8	-476.6	-504.4	-518.2

6 Accessories

6.1 Replacement Accessories

Part Number	Description
PHCN-45-CHART	One 30-day chart
PHCN-55-BATT	PHCN-55 replacement 6V battery
PHTM-1	Replacement 4-20mA pH Transmitter



WARRANTY

OMEGA warrants this unit to be free of defects in materials and workmanship and to give satisfactory service for a period of **13 months** from date of purchase. OMEGA Warranty adds an additional one (1) month grace period to the normal **one (1) year product warranty** to cover handling and shipping time. This ensures that OMEGA's customers receive maximum coverage on each product. If the unit should malfunction, it must be returned to the factory for evaluation. OMEGA's Customer Service Department will issue an Authorized Return (AR) number immediately upon phone or written request. Upon examination by OMEGA, if the unit is found to be defective it will be repaired or replaced at no charge. However, this WARRANTY is VOID if the unit shows evidence of having been tampered with or shows evidence of being damaged as a result of excessive corrosion; or current, heat, moisture or vibration; improper specification; misapplication; misuse or other operating conditions outside of OMEGA's control. Components which wear or which are damaged by misuse are not warranted. These include contact points, fuses, and triacs.

OMEGA is glad to offer suggestions on the use of its various products. Nevertheless, OMEGA only warrants that the parts manufactured by it will be as specified and free of defects.

OMEGA MAKES NO OTHER WARRANTIES OR REPRESENTATIONS OF ANY KIND WHATSOEVER, EXPRESSED OR IMPLIED, EXCEPT THAT OF TITLE AND ALL IMPLIED WARRANTIES INCLUDING ANY WARRANTY OF MERCHANTABILITY AND FITNESS FOR A PARTICULAR PURPOSE ARE HEREBY DISCLAIMED.

LIMITATION OF LIABILITY: The remedies of purchaser set forth herein are exclusive and the total liability of OMEGA with respect to this order, whether based on contract, warranty, negligence, indemnification, strict liability or otherwise, shall not exceed the purchase price of the component upon which liability is based. In no event shall OMEGA be liable for consequential, incidental or special damages.

Every precaution for accuracy has been taken in the preparation of this manual; however, OMEGA ENGINEERING, INC. neither assumes responsibility for any omissions or errors that may appear nor assumes liability for any damages that result from the use of the products in accordance with the information contained in the manual.

SPECIAL CONDITION: Should this equipment be used in or with any nuclear installation or activity, purchaser will indemnify OMEGA and hold OMEGA harmless from any liability or damage whatsoever arising out of the use of the equipment in such a manner.

RETURN REQUESTS / INQUIRIES

Direct all warranty and repair requests/inquiries to the OMEGA ENGINEERING Customer Service Department. BEFORE RETURNING ANY PRODUCT(S) TO OMEGA, PURCHASER MUST OBTAIN AN AUTHORIZED RETURN (AR) NUMBER FROM OMEGA'S CUSTOMER SERVICE DEPARTMENT (IN ORDER TO AVOID PROCESSING DELAYS). The assigned AR number should then be marked on the outside of the return package and on any correspondence.

FOR **WARRANTY** RETURNS, please have the following information available BEFORE contacting OMEGA:

1. P.O. number under which the product was PURCHASED,
2. Model and serial number of the product under warranty, and
3. Repair instructions and/or specific problems relative to the product.

FOR **NON-WARRANTY** REPAIRS OR **CALIBRATION**, consult OMEGA for current repair/calibration charges. Have the following information available BEFORE contacting OMEGA:

1. P.O. number to cover the COST of the repair/ calibration,
2. Model and serial number of product, and
3. Repair instructions and/or specific problems relative to the product.

OMEGA's policy is to make running changes, not model changes, whenever an improvement is possible. This affords our customers the latest in technology and engineering.

OMEGA is a registered trademark of OMEGA ENGINEERING, INC.

© Copyright 1995 OMEGA ENGINEERING, INC. All rights reserved. This documentation may not be copied, photocopied, reproduced, translated, or reduced to any electronic medium or machine-readable form, in whole or in part, without prior written consent of OMEGA ENGINEERING, INC.

Where Do I Find Everything I Need for Process Measurement and Control? OMEGA...Of Course!

TEMPERATURE

- Thermocouple, RTD & Thermistor Probes, Connectors, Panels & Assemblies
- Wire: Thermocouple, RTD & Thermistor
- Calibrators & Ice Point References
- Recorders, Controllers & Process Monitors
- Infrared Pyrometers

PRESSURE/STRAIN FORCE

- Transducers & Strain Gages
- Load Cells & Pressure Gauges
- Displacement Transducers
- Instrumentation & Accessories

FLOW/LEVEL

- Rotameters, Gas Mass Flowmeters & Flow Computers
- Air Velocity Indicators
- Turbine/Paddlewheel Systems
- Totalizers & Batch Controllers

pH/CONDUCTIVITY

- pH Electrodes, Testers & Accessories
- Benchtop/Laboratory Meters
- Controllers, Calibrators, Simulators & Pumps
- Industrial pH & Conductivity Equipment

DATA ACQUISITION

- Data Acquisition and Engineering Software
- Communications-Based Acquisition Systems
- Plug-in Cards for Apple, IBM & Compatibles
- Datalogging Systems
- Recorders, Printers & Plotters

HEATERS

- Heating Cable
- Cartridge & Strip Heaters
- Immersion & Band Heaters
- Flexible Heaters
- Laboratory Heaters

ENVIRONMENTAL MONITORING AND CONTROL

- Metering & Control Instrumentation
- Refractometers
- Pumps & Tubing
- Air, Soil & Water Monitors
- Industrial Water & Wastewater Treatment
- pH, Conductivity & Dissolved Oxygen Instruments