

**65E10 CONTROL SERIES**

# **DART**

---

# **CONTROLS**

---

---

---

---

## **Instruction Manual**

**For DC Input Variable Speed Controls**

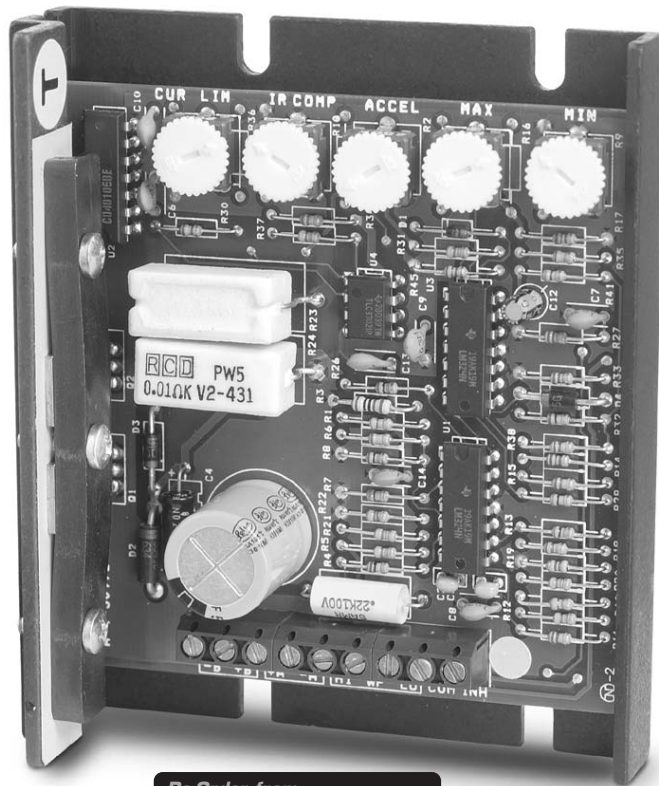

Re-Order from  
**Omegamation™**  
**1-888-55-66342**  
**1-888-55-OMEGA**  
[omegamation.com](http://omegamation.com)

**P.O. Box 10**  
**5000 W. 106th Street**  
**Zionsville, Indiana 46077**

**Phone (317) 873-5211**  
**Fax (317) 873-1105**  
[www.dartcontrols.com](http://www.dartcontrols.com)

# TABLE OF CONTENTS

WARRANTY .....	1
STANDARD FEATURES .....	1
CONTROL DIMENSIONS .....	1
MOUNTING DIMENSIONS .....	2
65E10 MOUNTING .....	2
INSTALLATION .....	2
HOOK-UP DIAGRAMS .....	2
65E10 HOOK-UP DIAGRAM .....	3
65E10 REVERSING HOOK-UP DIAGRAM .....	3
INHIBITING THE CONTROL .....	4
TRIMPOT ADJUSTMENTS .....	4
IN CASE OF DIFFICULTY .....	4
MODEL SELECTION .....	5
SPECIFICATIONS .....	5

## WARRANTY

**Dart Controls, Inc. (DCI)** warrants its products to be free from defects in material and workmanship. The exclusive remedy for this warranty is DCI factory replacement of any part or parts of such product which shall within 12 months after delivery to the purchaser be returned to DCI factory with all transportation charges prepaid and which DCI determines to its satisfaction to be defective. This warranty shall not extend to defects in assembly by other than DCI or to any article which has been repaired or altered by other than DCI or to any article which DCI determines has been subjected to improper use. DCI assumes no responsibility for the design characteristics of any unit or its operation in any circuit or assembly. This warranty is in lieu of all other warranties, express or implied; all other liabilities or obligations on the part of DCI, including consequential damages, are hereby expressly excluded.

NOTE: Carefully check the control for shipping damage. Report any damage to the carrier immediately. Do not attempt to operate the drive if visible damage is evident to either the circuit or to the electronic components.

All information contained in this manual is intended to be correct, however information and data in this manual are subject to change without notice. DCI makes no warranty of any kind with regard to this information or data. Further, DCI is not responsible for any omissions or errors or consequential damage caused by the user of the product. DCI reserves the right to make manufacturing changes which may not be included in this manual.

### WARNING

Improper installation or operation of this control may cause injury to personnel or control failure. The control must be installed in accordance with local, state, and national safety codes. Make certain that the power supply is disconnected before attempting to service or remove any components!!! If the power disconnect point is out of sight, lock it in disconnected position and tag to prevent unexpected application of power. Only a qualified electrician or service personnel should perform any electrical troubleshooting or maintenance. At no time should circuit continuity be checked by shorting terminals with a screwdriver or other metal device.

## STANDARD FEATURES

- Provides smooth variable speed capability for mobile equipment
- Maintains variable speed control as batteries discharge
- Adjustable maximum speed, minimum speed, current limit, I.R. compensation, and accel
- Inhibit terminal permits optional start-stop without breaking battery lines
- Speed potentiometer, knob, and dialplate included
- Increases range or running time of battery operated equipment through high efficiency

## CONTROL DIMENSIONS

MODEL	WIDTH	LENGTH	DEPTH	WEIGHT
	inches (centimeters)			oz. (gms.)
65E10	3.625 (9.21)	4.25 (10.76)	1.30 (3.30)	6.0 (170)

# MOUNTING DIMENSIONS

## 65E10 MOUNTING

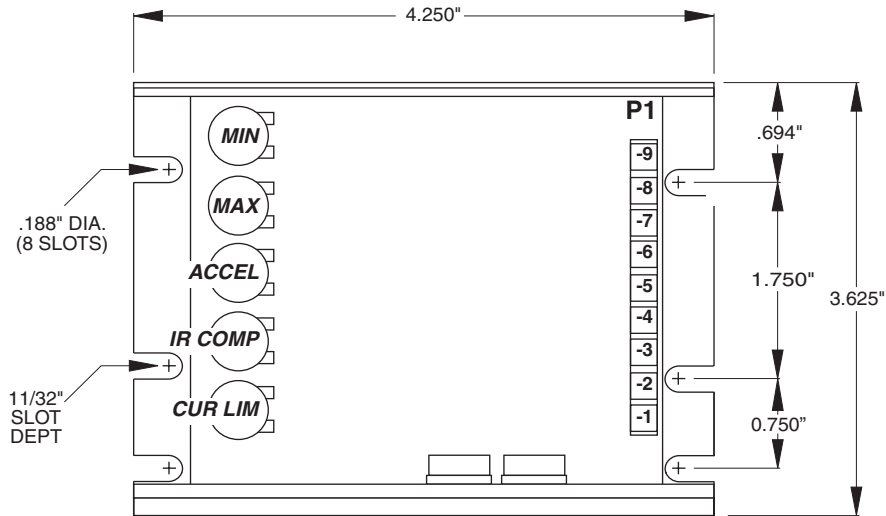

TOP VIEW

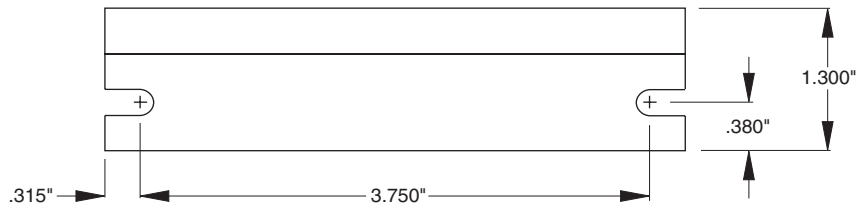

SIDE VIEW

**Caution: Do not mount controller where ambient temperature is outside the range of -10° C (15° F) to 45° (115° F).**

## INSTALLATION

Before attempting to wire the control, make sure all power is disconnected. Recheck code designation to assure proper voltage is present for the control. Caution should be used in selecting proper size of hook-up wire for current and voltage drop.

## HOOK-UP DIAGRAMS

### WARNING:

**DO NOT REVERSE POSITIVE AND NEGATIVE BATTERY LEADS. THIS WILL DAMAGE THE CONTROL. TO CHANGE MOTOR DIRECTION, INTERCHANGE THE POSITIVE AND NEGATIVE ARMATURE LEADS.**

Refer to the wiring diagrams below for proper connection of **DC Voltage**, **Armature**, and **Speedpot wiring** to the control.

**CAUTION!!** TURN POWER OFF WHILE MAKING CONNECTIONS.

To properly adjust the CURRENT LIMIT setting, a DC ammeter should be placed in series with the armature line. This meter can be removed after the control is adjusted.

## 65E10 HOOK-UP DIAGRAM

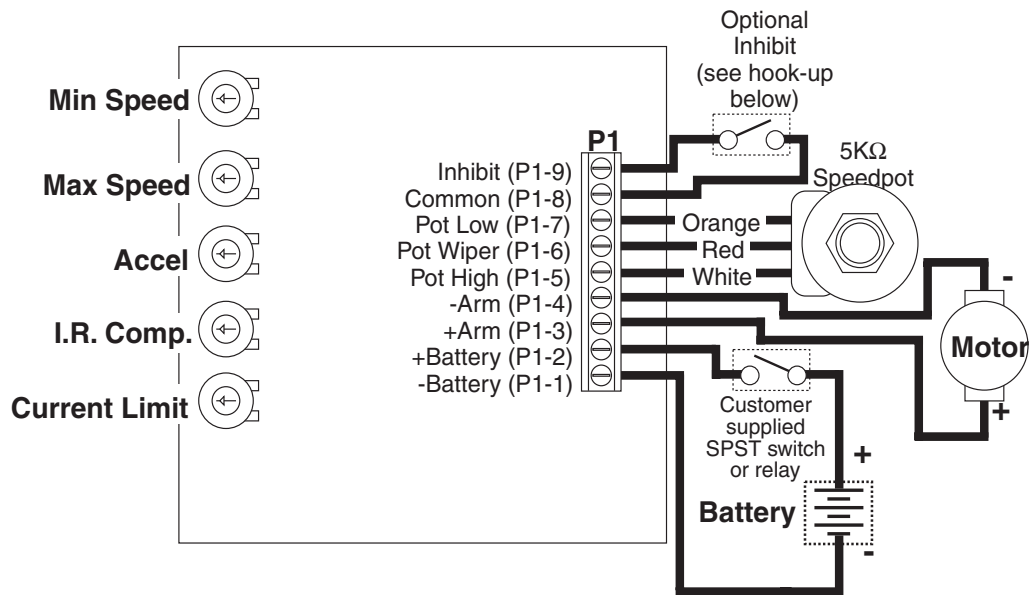

## 65E10 REVERSING HOOK-UP DIAGRAM

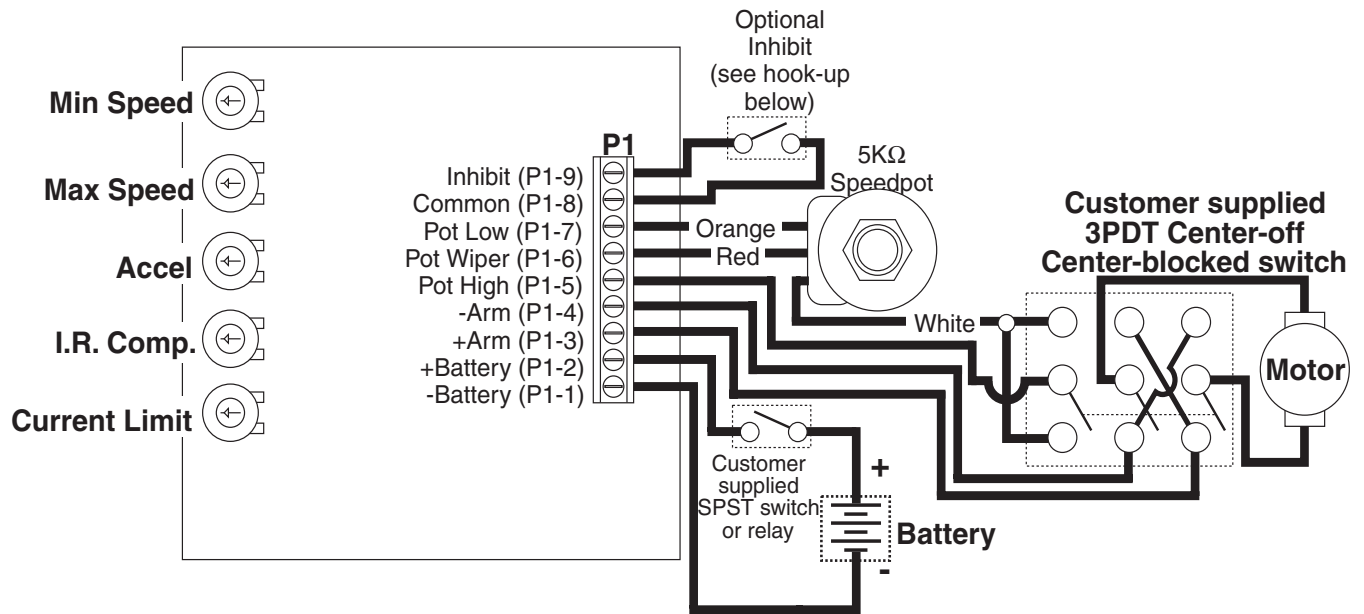

Caution: When reversing a spinning motor, caution must be taken that the resulting current through the armature of the motor does not exceed the overload ratings of the control, or the demagnetize rating of the motor being reversed when using a permanent magnet DC motor.

# INHIBITING THE CONTROL

**Using inhibit input** - provides fast start-stop by bypassing accel/decel circuit

**Inhibit via speedpot** - provides starting and stopping through accel/decel parameters

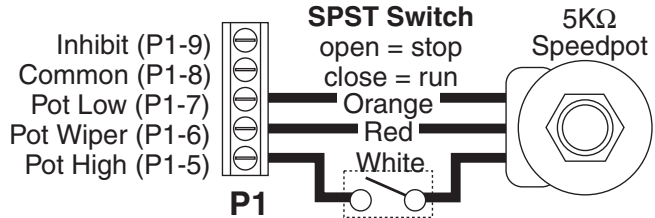
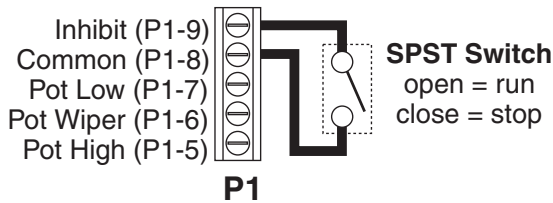

Note: Always use a shielded cable when connecting to the inhibit terminal. The shield of the cable should connect to the Common terminal of the control.

## TRIMPOT ADJUSTMENTS

Before the power is applied, the speed potentiometer and trimpots should be preset as follows:

### TRIMPOT PRESET

1. Preset speedpot fully CCW, preset Max trimpot CW 1/2 way, preset Current Limit trimpot fully CW, preset Min trimpot fully CCW, preset Accel trimpot CW 1/2 way, preset I.R. trimpot fully CCW.

**DC power can now be applied** to the system and the control adjusted as directed below:

### TRIMPOT ADJUSTMENT

2. Increase the **MIN** trimpot in a clockwise direction until just before reaching an output voltage (deadband) or until the desired minimum speed is reached.
3. Turn the Speedpot fully clockwise and adjust the **MAX** trimpot until the desired maximum speed is reached.
4. Adjust the **ACCEL** trimpot to achieve the desired soft start time. CW rotation will increase accel time.
5. Rotate the **CURRENT LIMIT** trimpot fully CCW. Apply a full load to the motor. While motor is stalled adjust the **CURRENT LIMIT** trimpot CW until a desired current setting is obtained. Approximately 125% of rated motor current is recommended.
6. Set speedpot to approximately 50% and note the motor RPM. Load the motor to normal load condition and adjust I.R. trimpot CW until motor RPM is equal to unloaded speed.

## IN CASE OF DIFFICULTY

PROBLEM	POSSIBLE CAUSE(S)	CORRECTIVE ACTION
Motor doesn't run	<ul style="list-style-type: none"> <li>• Incorrect or no power</li> <li>• Speedpot set at zero</li> <li>• Worn motor brushes</li> <li>• Current limit set too low</li> </ul>	Install proper service Rotate speedpot fully CW Replace motor brushes Adjust current limit trimpot CW
Motor "hunts"	<ul style="list-style-type: none"> <li>• Max trimpot set too high</li> <li>• I.R. Comp. trimpot set too high</li> </ul>	See "Trimpot Adjustments" - page 3-4 See "Trimpot Adjustments" - page 3-4
Motor runs at "full speed" uncontrollable	<ul style="list-style-type: none"> <li>• Loose speedpot connections</li> <li>• Min. or Max. trimpots not properly adjusted</li> <li>• Possible control failure</li> </ul>	Secure all connections See "Trimpot Adjustments" - page 3-4 Send to Dart Controls, Inc.
Motor rotates in wrong direction	<ul style="list-style-type: none"> <li>• Motor armature hooked up backwards</li> </ul>	Reverse armature + and - leads
Motor stalls under a light load	<ul style="list-style-type: none"> <li>• Current limit trimpot improperly adjusted</li> </ul>	See "Trimpot Adjustments" - page 3-4

If a newly installed control will not operate, it is likely that a terminal or connection is loose. Check to make sure connections are secure and correct. If the control is still inoperative, refer to the following chart for reference:

# MODEL SELECTION

INPUT VOLTAGE	OUTPUT VOLTAGE	CONTINUOUS CURRENT	MODEL NUMBER
12 VDC $\pm$ 15%	0 - 12 VDC	10 amps D.C.	65E10-12
24 VDC $\pm$ 15%	0 - 24 VDC	10 amps D.C.	65E10*
36 VDC $\pm$ 15%	0 - 36 VDC	10 amps D.C.	65E10*

\* 24 volt and 36 volt units with the same current ratings are interchangeable (ie. 24 volt unit will operate with 36 volt input and a 36 volt unit will operate with 24 volt input, same current rating).

# SPECIFICATIONS

	<b>65E10</b>
Load current (continuous)	10 amps
Speed adjustment	5K $\Omega$ potentiometer <i>or</i> 0 to +10VDC input signal
Speed range	30 : 1
Overload capacity	200% for 10 seconds; 150% for one minute
Current limit	adjustable 100% to 200% of full motor load, up to 200% of control current rating
Acceleration	adjustable - 0 to 10 seconds
Deceleration	non-adjustable - 0.5 seconds
Maximum speed	adjustable - 50 to 100% of base speed
Minimum speed	adjustable - 0 to 30% of max speed
Connections	Euro-style terminal block (14Ga. to 28Ga..)
Speed regulation	1% of base speed via adjustable I.R. Compensation trimpot
Operating temperature	-10°C to +45°C (14°F to 113°F)
Package configuration	black anodized aluminum extrusion
Internal operating frequency	approximately 18K Hertz

**NOTES:**

# REPAIR PROCEDURE

In the event that a Product manufactured by Dart Controls Incorporated (DCI) is in need of repair service, it should be shipped, freight paid, to: Dart Controls, Inc., 5000 W. 106th Street, Zionsville, IN. 46077, ATTN: Repair Department.

Those orders received from anyone without an existing account with DCI will need to specify if they will be paying COD or Credit Card (Master Card or Visa). This information is required before work can begin. If you have an account with Dart your order will be processed according to the terms listed on your account.

Completed repairs are returned with a Repair Report that states the problem with the control and the possible cause. Repair orders are returned via UPS Ground unless other arrangements are made. If you have further questions regarding repair procedures, contact your Dart Controls, Inc. at 317-733-2133 Ext.460.

## YOUR MOTOR SPEED CONTROL SOLUTIONS PROVIDER



**125D SERIES**  
AC INPUT - VARIABLE DC OUTPUT  
1/50 HP through 1.0 HP



**250G SERIES**  
AC INPUT - VARIABLE DC OUTPUT  
1/50 HP through 2.0 HP



**65 SERIES**  
DC INPUT - VARIABLE DC OUTPUT  
CURRENT RATINGS OF 20, 40, AND  
60 AMPS



**700/COMMUTROL SERIES**  
DC BRUSHLESS  
5 & 20 Amp for  
12,24,& 36VDC Inputs



**MDP SERIES**  
PROGRAMMABLE  
CLOSED LOOP DC  
SPEED CONTROL



**DM SERIES**  
FIELD PROGRAMMABLE  
DIGITAL TACHOMETER

Dart Controls, Inc. is a designer, manufacturer, and marketer of analog and digital electronic variable speed drives, controls, and accessories for AC, DC, and DC brushless motor applications.

Shown above is just a sampling of the expanded line of Dart controls that feature the latest in electronic technology and engineering. Products are manufactured in the U.S.A. at our Zionsville (Indianapolis,

Indiana) production and headquarters facility - with over 2,000,000 variable speed units in the field.

In addition to the standard off-the-shelf products, you can select from a wide variety of options to customize controls for your specific application. For further information and application assistance, contact your local Dart sales representative, stocking distributor, or Dart Controls, Inc.

## Dart Controls, Inc.

*Manufacturer of high quality DC and AC motor speed controls and accessories since 1963.*

P.O. Box 10  
5000 W. 106th Street  
Zionsville, Indiana 46077  
Phone: (317) 733-2133  
Fax: (317) 873-1105