

USER'S GUIDE

WT4401-S & WT4401-D

Benchtop Wind Tunnels

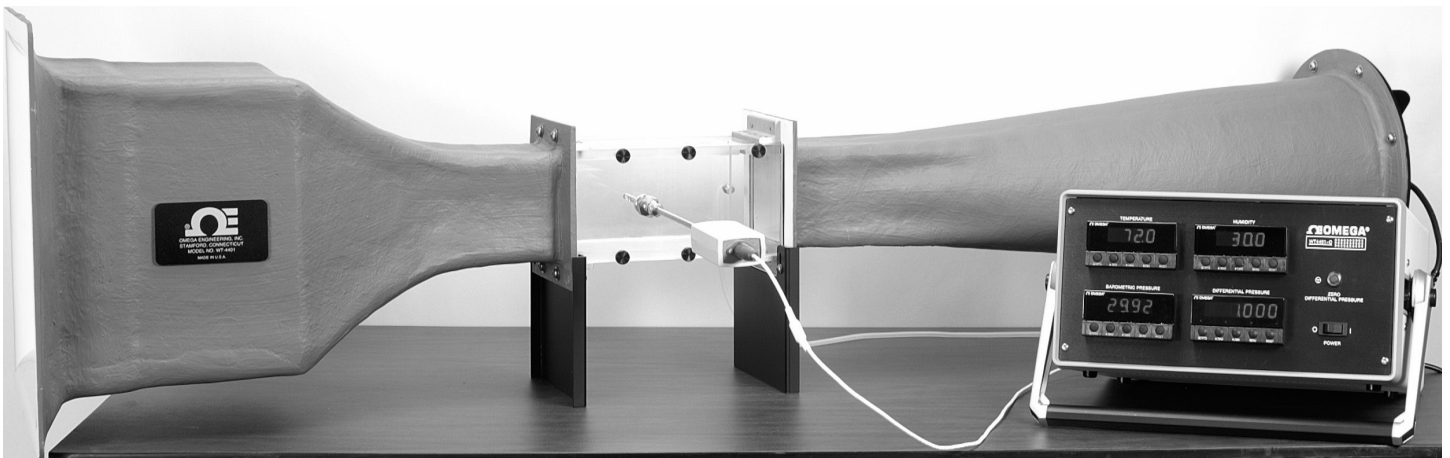

omega.com | info@omega.com

For latest product manuals:
omega.com/en-us/pdf-manuals

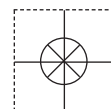

1 YEAR
WARRANTY

CONTACT

Omega Engineering, Inc.

omega.com/contact-us

Toll-Free:

1-800-826-6342 (USA & Canada only)

Customer Service:

1-800-622-2378 (USA & Canada only)

Engineering Service:

1-800-872-9436 (USA & Canada only)

Telephone:

(203) 359-1660

Fax:

(203) 359-7700

Email: info@omega.com

For other locations visit:

omega.com/worldwide

Table of Contents

1. Introduction	4
1.1. Product Description	4
1.2. Unpacking.....	5
2. Setting Up the Wind Tunnel	6
2.1. Precautions	6
2.2. Setup Procedure	6
3. Installing the Wind Tunnel	10
4. Operating Instructions.....	12
5. Calibrating at Other Flow Rates Not Listed in the Calibration Sheets.....	13
6. Specifications	14
7. In Case of Problems.....	15
8. Maintenance.....	15
9. Spare Parts and Replacement Parts	16
10. Appendix A: Differential Pressure Fluctuation Errors.....	17
11. Appendix B: Barometric Pressure Calculations.....	19

1. Introduction

1.1. Product Description

The WT4401-S and WT4401-D wind tunnels are designed to give a uniform flow rate over a 101.6 mm x 101.6 mm (4 in x 4 in) test cross section. A powerful 12 A motor varying from 0 RPM to 10,000 RPM is adjusted to give a particular flow rate by a precision motor control unit. Once a known flow rate is established the air probe under test is read or calibrated. Each wind tunnel is supplied with NIST traceable certificates. The uniform flow rate is determined by monitoring a differential pressure between taps (tubing connections) provided (refer to Figure 1). OMEGA offers a complete line of differential pressure transducers. The one model most commonly used with this wind tunnel is model PX657-5DI. Panel meters and bench top meters also come with the wind tunnel in comprehensive electronics boxes. Figure 2 shows both types of electronics boxes.

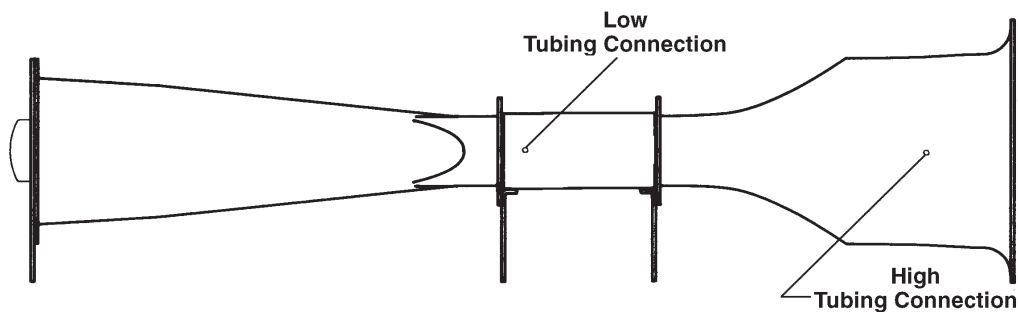

Figure 1: Location of Tubing Connections

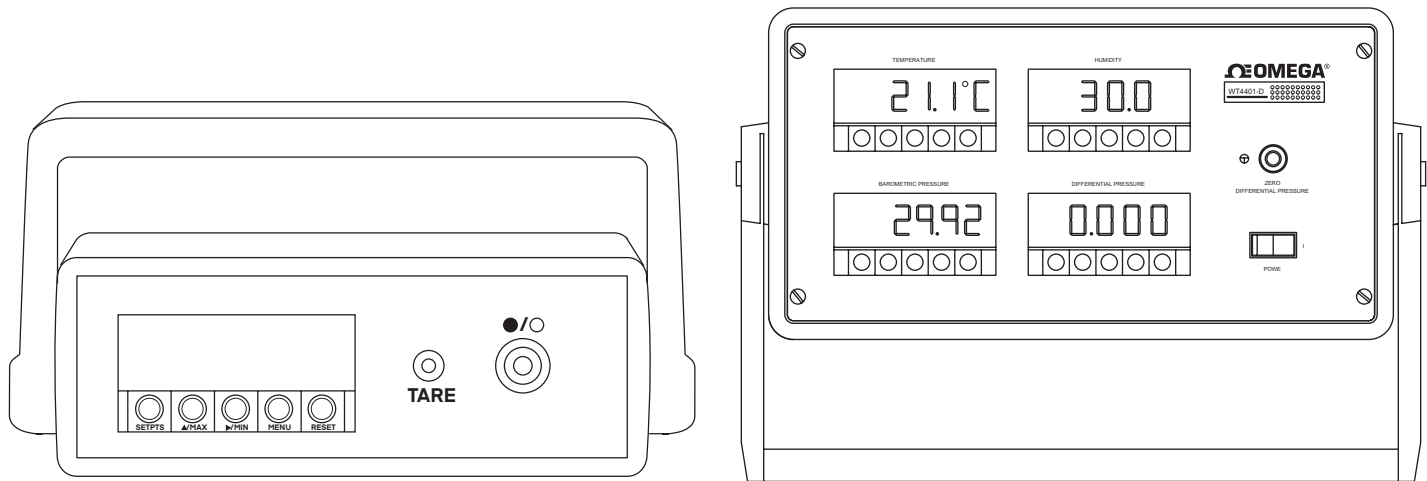

Figure 2: Standard Electronics Box(Left) and Deluxe Electronics Box (Right)

A differential pressure measurement used to establish known flow rates is affected by barometric pressure, and temperature conditions during testing. Depending on the probe being calibrated, humidity might also be a factor. OMEGA offers a complete system to monitor differential pressure, ambient barometric pressure, ambient temperature, and ambient humidity conditions. Each wind tunnel is supplied with two restrictive plates for achieving optimum lower flow rates. The established differential pressure measurements versus flow rates are listed from 25 FPM to 9000 FPM. Calibration sheets are included to make calibrating different flow sensors simple. An assortment of compression fittings is provided to help mount your probe under calibration.

This system features:

- Compact design to take up "little bench-top space"
- Precise motor control for adjusting flow rates
- NIST calibration sheets supplied with each wind tunnel

- Highly accurate to 1% of reading
- Large 101.6 mm x 101.6 mm (4 in x 4 in) test chamber
- Highly stable delta pressure sensor and readout(s) included with each wind tunnel
- Optional environmental monitoring package of temperature, humidity, barometric pressure and delta pressure available

1.2. Unpacking

Remove the Packing List and verify that you have received all equipment. If you have any questions about the shipment, please call the OMEGA Customer Service Department at 1-800-622-2378 or (203) 359-1660.

When you receive the shipment, inspect the container and equipment for any signs of damage. Note any evidence of rough handling in transit. Immediately report any damage to the shipping agent.

Note

The carrier will not honor any claims unless all shipping material is saved for their examination. After examining and removing contents, save packing material and carton in the event reshipment is necessary.

If you ordered the WT4401-S you get:

- 1 Wind Tunnel
- 1 Electronics Box* (serial number must match the serial number on the wind tunnel)
- 1 Restrictive Plate A
- 1 Restrictive Plate B
- 1 Motor Controller
- 2 5-foot pieces of Silicone Tubing
- 1 Package of Brass Compression Fittings with Teflon Ferrules (sizes - 3.175 mm [1/8 in], 4.762 [3/16 in], 6.35 mm [1/4 in], 9.525 mm [3/8 in])
- 6 Calibration Report Sheets (3 in metric units, 3 in English units)
- 1 Operator's Manual for DP41-S Indicator
- 1 Quick Reference Guide for the DP41-S Indicator
- 1 Operator's Manual for the Motor Controller
- 1 Operator's Manual for Wind Tunnel

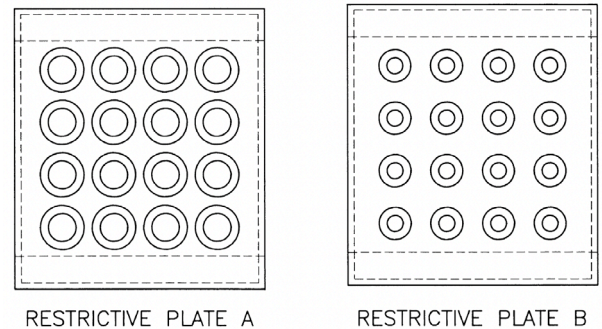

Figure 3: Restrictive Plate A and B

If you ordered the WT-4401-D (deluxe system) you also get the following items:

- 1 Operator's Manual for DP25-E panel meter
- 1 Calibration Sheet for the barometer

If you ordered WT4401-S, you get the standard electronics box; if you ordered WT4401-D, you get the deluxe electronics box.

Note

All meters used in either the standard or deluxe electronics package have a 10 V dc analog output.

2. Setting Up the Wind Tunnel

2.1. Precautions

A wind tunnel's performance can be severely diminished if not used with the following considerations in mind.

- Do not use the wind tunnel in small rooms with less than 1,800 cubic feet. The air flow creates currents that undermine the wind tunnel's accuracy.
- Avoid locating the intake and exhaust toward open windows, doorways or corridors where people are walking. The effect of air current changes across the intake has a severe affect on the flow rate changing in the wind tunnel.
- Locate the exhaust towards the largest open area of the room to minimize room air currents. Naturally the higher the flow rate, the more chance of creating currents exists.

2.2. Setup Procedure

Refer to the table below for flow ranges.

Flow Ranges		
Wind Tunnel Configuration	Flow Ranges	Accuracy
No restrictive plate used	1000 fpm to 7500 fpm	1 % reading
Restrictive Plate A used	250 fpm to 1500 fpm	2 % reading
Restrictive Plate B used	25 fpm to 300 fpm	2 % reading

After determining which flow range you wish to calibrate at, and whether you need a restrictive plate, go through the following procedure to install it or remove it.

1. Remove two thumbscrews and remove the small plexiglass cover.
2. Inspect the gasket around the four sides of restrictive plate first. The gasket should provide a good seal when the plate is inserted into the slots. If not, replace it. It would be a good idea to have extra gaskets on hand.
3. Slide restrictive plate into the slots in the center of the wind tunnel. Keep the flat side upstream. Refer to Figure 4 for the proper orientation of the restrictive plate. Or remove the plate if you don't need it.
4. Replace plexiglass cover and screws.

Figure 5 shows the direction of air flow through one type of restrictive plate. Chapter 3 describes how to set up the whole Wind Tunnel including the Electronics Instrument Box both of which are shown in Figures 6 and Figure 7.

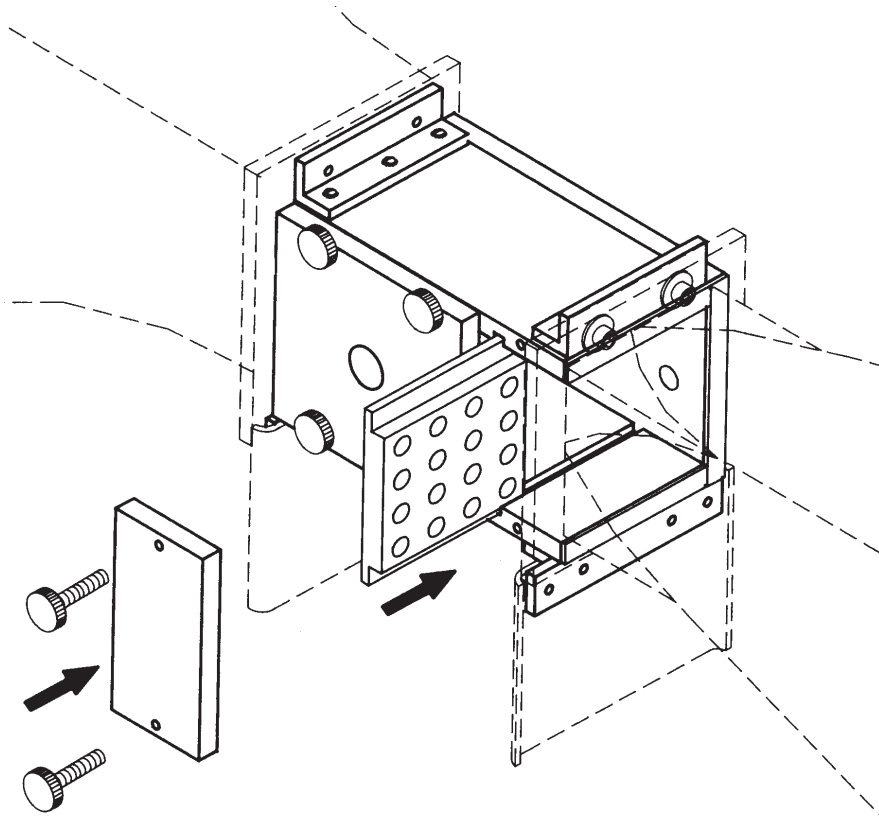

Figure 4: Restrictive Plate Placement

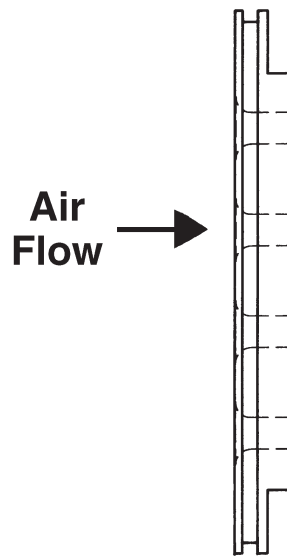

Figure 5: Air Flow

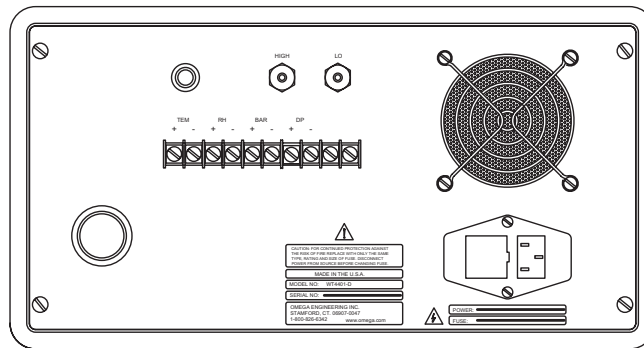
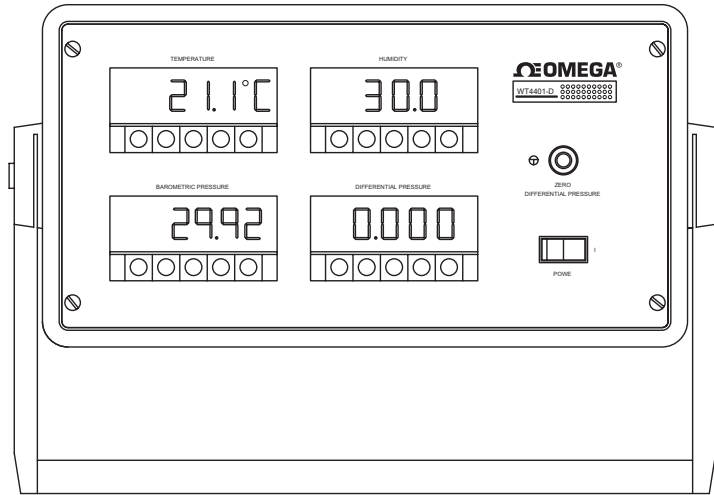

Figure 6: Standard Electronics Box; Top (Front); Bottom (Rear)

The TARE button on the front of the electronics box is used to zero out the meter.

The ON/OFF power button is to its right.

The REC connector is used to hook up any device with 10 V dc analog output. As shown in the bottom figure, the power cord receptacle is rated for a 115 V ac power cord.

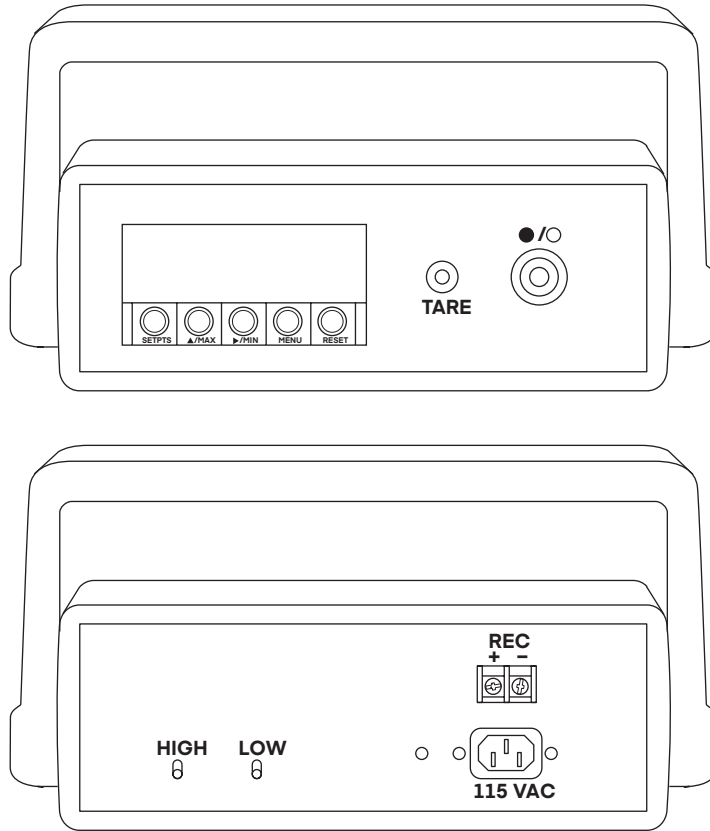

Figure 7: Deluxe Electronics Box Top (Front); Bottom (Rear)

The TARE button on the front of the electronics box is used to zero out the Differential Pressure meter only. The ON/OFF power button is below it.

The bottom terminal strip labeled TEMP/RH/BAR/DP is used to hook up any device with 10 V dc analog output. As shown in the bottom figure, the power cord receptacle is rated for a 115 V ac power cord.

3. Installing the Wind Tunnel

Follow the instructions below to install the wind tunnel.

Step 1: After unpacking the box, place the wind tunnel on a level table top. Refer to Section 2 on how to select the correct size room and how to orient the wind tunnel correctly in the room.

Step 2: Set up the motor controller. To do this, examine that the ON/OFF switch on the controller box is in the OFF position and be certain that the potentiometer is fully counter-clockwise. Connect the two elongated connectors together to hook up the motor and plug the motor controller into a live 120 V ac outlet. DO NOT TURN ON THE CONTROLLER.

Step 3: Place the electronics box next to the tunnel. Attach the two (2) pieces of tubing as shown in Figure 8. Also attach the power cord to the rear of the box. DO NOT TURN ON THE ELECTRONICS BOX YET EITHER.

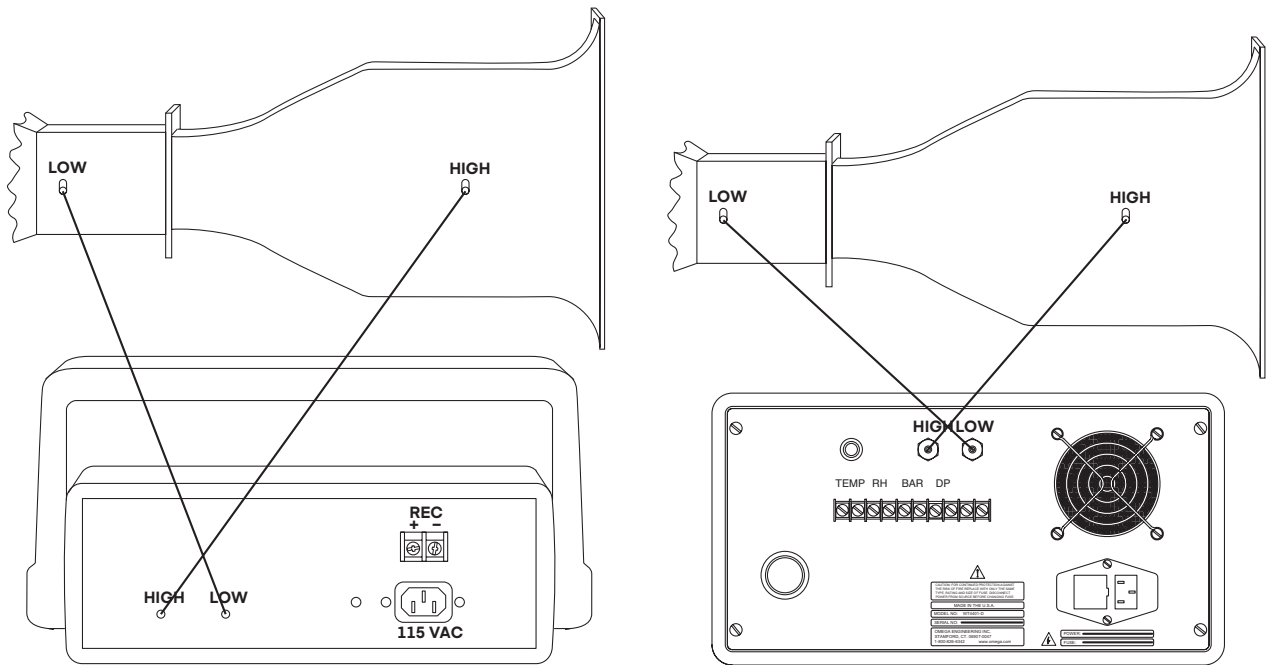

Figure 8: (Left) Tubing Placement with Standard Electronics Box and Wind Tunnel
(Right) Tubing Placement with Deluxe Electronics Box and Wind Tunnel

Step 4: Using the compressing fittings provided, mount the probe to be calibrated in the wind tunnel. Refer to Figure 9. Some probes have directional air flow for upstream and downstream sides. Make sure the probe is installed without any leaks.

Step 5: Continue to Section 4 Operating Instructions.

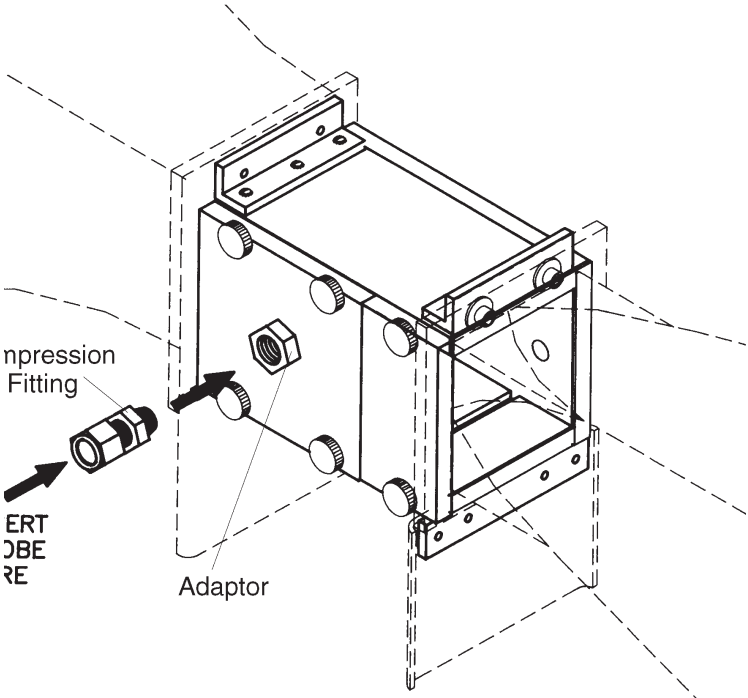

Figure 9: Probe Placement

4. Operating Instructions

Important

Always keep your original calibration reports in good, clean condition for future copying. Make duplicate copies of the calibration reports you desire.

The differential pressures recorded in column 2 are at lab conditions (ΔP_s). Standard conditions are at 21.1 °C (70 °F) and 29.92 in Hg. Since your test will not be at the same conditions you need to calculate what the actual differential pressures (ΔP_a) will be during your operating conditions. A correction factor for air density (K) needs to be determined. Differential pressures at standard conditions are listed in Appendix A.

Step 1: Supplied with the wind tunnel are Calibration Report sheets. Your wind tunnel can be used in different applications: with no Restrictive Plate, with Restrictive Plate A or with Restrictive Plate B. Each pair of sheets for each plate style is further broken down to two different units of measure - feet per minute and meters per second. Examine the differences between the sheets and obtain the applicable Calibration Report sheet for your application and photocopy it.

Step 2: Fill in the ambient barometric pressure and ambient temperature in the space provided on the Calibration Report. Using the "K" formula on the sheets and a calculator, figure out the K factor. Take each value in column 2 and multiply it by K and write the values in column 3.

Column 3 is the differential pressures that will correspond to the given flow rates in column 1. The values in column 3 will be used in the wind tunnel setup. The top part of a calibration report is shown on the next page. If you do not have a barometer, refer to Appendix B.

Step 3: Turn on the electronics box. If you need to zero the display, press the TARE button (on the Deluxe Electronics Box the only display that is zeroed is the Differential Pressure display).

Step 4: Turn on the motor by flipping on the ON/OFF switch and turning the potentiometer slowly clockwise and increase the motor speed until the actual differential pressure in column 3 is achieved.

At high speed, you will notice that the differential display tends to jump around a little which makes it tough to get the exact same ΔP as indicated in column 3. Refer to Appendix A for this effect.

Step 5: Record the velocity from the air probe under calibration in column 4.

Step 6: Continue increasing the flow rates until you have covered the complete range you wish to calibrate.

CALIBRATION REPORT

Report Number:

Serial Number:

Model Number:

Range:

Date Calibrated:

Due Date:

Correction Factor: $K = (29.92/P) \times (460+T)/530 =$ _____

Where Tested Atmospheric Conditions:

P= Barometric Pressure = _____ (in Hg)

T= Atm Pressure = _____ (F)

NO RESTRICTIVE PLATES

STANDARD		ACTUAL = $P_s (K)$	UNIT UNDER TEST
VELOCITY (FPM) column 1	P_s (mmHg) column 2	P_a (mmHg) column 3	column 4

Figure 10: Calibration Report

5. Calibrating at Other Flow Rates Not Listed in the Calibration Sheets

To determine the ΔP that corresponds to the desired flow rate use the following formula:

$$P_2 = P_1 \left[\frac{V_2}{V_1} \right]^2$$

where: P_1 is the delta P corresponding to velocity 1

P_2 is the delta P corresponding to velocity 2

V_1 is a known velocity from the Calibration tables

V_2 is a desired velocity not listed in the Calibration tables

Sometimes a given delta P is observed and you would like to know what flow rate it corresponds to (use the following formula):

$$V_2 = V_1 \sqrt{\frac{P_2}{P_1}}$$

where: P_1 is the known actual delta P from column 4 in tables

P_2 is the measured ΔP

V_1 is the velocity from the tables corresponding to ΔP_1

V_2 is the velocity that corresponds to ΔP_2

6. Specifications

Wind Tunnel

Accuracy: 1 % reading (2 % rdg with restrictive plates)

Flow Rates: 0.15 m/s to 45 m/s (25 f/m to 9000 f/m)

Dimensions: Refer to Figure 6-1

Weight

Wind Tunnel: 22.45 kg (49.5 lb)

Standard Electronics: 3.18 kg (7 lb)

Deluxe Electronics: 6.94 kg (15.3 lb)

Restrictive Plates A & B

Material: Clear acrylic

Overall Size (H x W): 109.2 mm x 99.1 mm (4.3 in x 3.9 in)

Size of Holes (I.D.)

Restrictive Plate A: 10.97 mm (0.432 in)

Restrictive Plate B: 6.35 mm (0.250 in)

Motor

Power: 120 V ac

Current: 12 A

Speed: 10,000 rpm

Motor Controller

Power: 120 V ac

Speed Adj: 10-turn potentiometer

Internal Adj: min, max, acceleration and current limit

Size (W x L x H): 140 mm x 184 mm x 89 mm (5.53 in x 7.25 in x 3.5 in)

Weight: 666 g (23.5 oz)

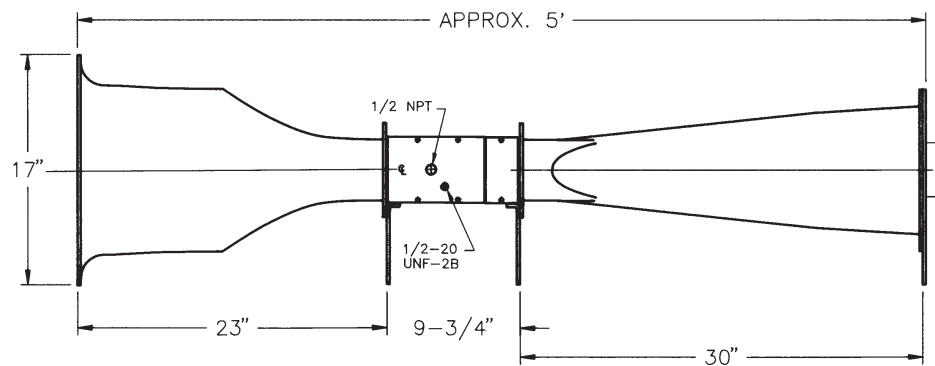

Figure 11: Dimensions

7. In Case of Problems

Problem	Solution
Scraping noise from area of fan	Realign position of the fan
The wind tunnel is not on -no power to motor	<ul style="list-style-type: none"> • Be sure the motor control-motor connector pieces are connected to each other. • Make sure the motor controller is plugged in and connected to a live outlet. • Check the fuse in the motor controller - if blown, replace with same type and rating.
The wind tunnel is not on -fan does not turn	<ul style="list-style-type: none"> • Make sure the motor controller is plugged in and connected to a live outlet. • Make sure the cabling from the motor controller is connected to the motor. • Make sure the ON/OFF switch on the motor controller is "ON". • If the switch on the motor controller is on, turn the 10-turn potentiometer clockwise from the "OFF" position. • Make sure there are no obstructions in the fan area of the wind tunnel.
Can't get velocity desired	<ul style="list-style-type: none"> • Check your AC power. • Check the position of the ON/OFF switch and potentiometer on the motor controller. • Make sure the appropriate restrictive plate is used in the wind tunnel - see Section 2 for the appropriate style to use. • Make sure the gasket around the restrictive plate is in good condition. If not, replace the gasket. • Clean restrictive plate if necessary. See Section 8 for details.
Poor repeatability	<ul style="list-style-type: none"> • Examine all hoses for any leaks and replace any if necessary. • Locate the wind tunnel in room that has AT LEAST 50.97 cubic meters (1800 cubic feet) of space.
Poor accuracy	Determine if the pressure transducer is operating correctly. If it is and there still is the accuracy problem, return the wind tunnel to the factory and get it recalibrated.
No readings from any of the readouts	Check the operation of the individual meters. Consult the appropriate operator's manuals provided for details.
Incorrect readings from any of the readouts	Check the operation of the individual meters. Consult the appropriate operator's manuals provided for details.

8. Maintenance

The following points should be adhered to for a maintenance-free operation of the wind tunnel.

- Make sure the wind tunnel is operating in a relatively dirt-free room that is AT LEAST 50.97 cubic meters (1,800 cubic feet).
- If the restrictive plate(s) should get dirty for any reason, they can be cleaned very easily using a mild soap or detergent.

Caution

Do not use any solvents.

- Make sure the silicone tubing is crimp-free and provides a good seal with the compression fittings. Replace if necessary.

9. Spare Parts and Replacement Parts

Description	Part Number
Restrictive Plate Cover	WT-0011
Restrictive Plate A	WT-0012
Restrictive Plate B	WT-0013
Restrictive Plate Gasket	WT-0014
Honeycomb Flow Straightener	WT-0022
Thumb Screw for Restrictive Plate Cover (Assembly)	WT-0060
One Piece of 1.5 m (5-ft) Silicone Tubing	KCC-0132

10. Appendix A: Differential Pressure Fluctuation Errors

Achieving the exact desired pressure measurement at high delta pressures is sometimes a tough thing to do. The fluctuations, although appearing to be large, are actually quite small. The table on the next page shows the delta pressure corresponding to a 1 % change in air flow velocity.

The reason why a large change in differential pressure causes only a 1 % change in the standard flow rate is because the flow rate is proportional to the square root of the ΔP . This square root relationship is shown as follows:

$$V_2 = V_1 \sqrt{\frac{P_2}{P_1}} \Rightarrow \frac{V_2}{V_1} = \sqrt{\frac{P_2}{P_1}}$$

$$\frac{V_1 + \Delta V}{V_1} = \sqrt{\frac{P_1 + \Delta P}{P_1}}$$

$$1 + \frac{\Delta V}{V_1} = \sqrt{1 + \frac{\Delta P}{P_1}} \Rightarrow \left(1 + \frac{\Delta V}{V_1}\right)^2 = 1 + \frac{\Delta P}{P_1}$$

The percentage change in pressure corresponding to a 1 % change in velocity is as follows:

$$(1 + 0.01)^2 = (1.0201) = 1 + \frac{\Delta P}{P_1} \Rightarrow 2.01\% = \frac{\Delta P}{P_1}$$

TYPICAL WIND TUNNEL DATA (ENGLISH UNITS - FPM)

RESTRICTIVE PLATE B			RESTRICTIVE PLATE A			NO PLATE		
Standard Velocity	Ps	Tol. on Press.	Standard Velocity	Ps	Tol. on Press.	Standard Velocity	Ps	Tol. on Press.
FPM	mm Hg	2% Vel	FPM	mm Hg	2% Vel	FPM	mm Hg	1% Vel
Col. 1	Col. 2	mm Hg	Col. 1	Col. 2	mm Hg	Col. 1	Col. 2	mm Hg
0	0.000	±0.000	0	0.000	±0.000	0	0.000	±0.000
25	0.023	±0.000	250	0.318	±0.006	1000	0.131	±0.001
30	0.043	±0.001	275	0.388	±0.008	1500	0.293	±0.003
40	0.070	±0.001	300	0.471	±0.009	2000	0.510	±0.005
50	0.110	±0.002	325	0.561	±0.011	3000	1.082	±0.011
60	0.175	±0.004	350	0.620	±0.012	4000	1.997	±0.020
70	0.235	±0.005	375	0.699	±0.014	5000	2.953	±0.030
80	0.288	±0.006	400	0.796	±0.015	6000	4.122	±0.041
90	0.359	±0.007	450	1.007	±0.020	7000	5.692	±0.057
100	0.459	±0.009	500	1.220	±0.024	8000	7.271	±0.073
125	0.681	±0.014	550	1.522	±0.031	9000	9.111	±0.091
150	1.001	±0.020	600	1.761	±0.035			
175	1.381	±0.028	700	2.534	±0.051			
200	1.867	±0.037	800	3.212	±0.064			
225	2.348	±0.047	900	3.900	±0.078			
250	2.875	±0.058	1000	5.466	±0.110			
275	3.525	±0.071	1250	8.399	±0.168			
300	4.354	±0.088						
325	5.156	±0.104						
350	5.837	±0.117						

(METRIC UNITS - m/s)

RESTRICTIVE PLATE B			RESTRICTIVE PLATE A			NO PLATE		
Standard Velocity	Ps	Tol. on Press.	Standard Velocity	Ps	Tol. on Press.	Standard Velocity	Ps	Tol. on Press.
m/s	mm Hg	2% Vel	m/s	mm Hg	2% Vel	m/s	mm Hg	1% Vel
Col. 1	Col. 2	mm Hg	Col. 1	Col. 2	mm Hg	Col. 1	Col. 2	mm Hg
0	0	±0.000	1.25	0.308	±0.006	7.5	0.286	±0.003
0.15	0.040	±0.001	1.3	0.333	±0.007	10	0.492	±0.005
0.2	0.065	±0.001	1.4	0.388	±0.008	12.5	0.739	±0.007
0.25	0.109	±0.002	1.5	0.457	±0.009	15	1.050	±0.011
0.3	0.168	±0.003	1.75	0.604	±0.012	20	1.872	±0.019
0.4	0.279	±0.006	2	0.764	±0.015	25	2.877	±0.029
0.5	0.447	±0.009	2.25	0.992	±0.020	30	3.990	±0.040
0.6	0.609	±0.012	2.5	1.176	±0.024	40	7.062	±0.071
0.75	0.983	±0.020	2.75	1.459	±0.029	45	8.089	±0.081
1	1.795	±0.036	3	1.707	±0.034			
1.25	2.838	±0.057	3.25	2.072	±0.041			
			3.5	2.488	±0.050			
			4	3.209	±0.064			
			4.5	3.834	±0.077			
			5	5.193	±0.104			
			5.5	6.005	±0.120			
			6.5	9.001	±0.180			

11. Appendix B: Barometric Pressure Calculations

Barometric pressure will affect the air density which influences the velocity readings. The deluxe electronics box will give the barometric pressure reading directly to you. If you do not have a barometer and wish to correct for the barometric pressure, an airport or a local weather station can provide a standard barometric reading. Please note that the reading they give you is standardized to sea level and 21.11 °C (70 °F).

The following correction formula can be used to determine the actual pressure at your location:

Let: Actual barometric pressure = BP_a
 Standard barometric pressure = BP_s
 Altitude above sea level = ALT
 Temperature in Rankine = T
 Specific air constant = 53.3 ft-lbf/lbm-R

$$BP_a = BP_s \left(e^{\frac{-ALT}{53.3 \times T}} \right)$$

Example: You are 15.24 m (50 ft) above sea level; the weather station reports 755.7 mmHg (29.75 inHg), and the temperature is 22.22 °C (72 °F).

So the equation would be:

$$BP_a = 29.75 \left(e^{\frac{-50}{53.3 \times (460+72)}} \right) = 29.70" \text{ Hg}$$

**Differential Pressures vs Airspeed at Standard Conditions of 70°F
(21.1°C) and 29.92 in Hg.**

mmHg	FPM	M/S	mmHg	FPM	M/S
0	0	0	2.46427	4600	23.37
0.00116	100	0.51	2.57257	4700	23.87
0.00466	200	1.02	2.68321	4800	24.38
0.01048	300	1.52	2.79617	4900	24.89
0.01863	400	2.03	2.91147	5000	25.4
0.02911	500	2.54	3.02909	5100	25.91
0.04193	600	3.05	3.14904	5200	26.41
0.05706	700	3.56	3.27132	5300	26.92
0.07453	800	4.06	3.39593	5400	27.43
0.09433	900	4.57	3.52287	5500	27.94
0.11646	1000	5.08	3.65214	5600	28.45
0.14091	1100	5.59	3.78374	5700	28.95
0.1677	1200	6.1	3.91767	5800	29.46
0.19682	1300	6.6	4.05393	5900	29.97
0.22826	1400	7.11	4.19251	6000	30.48
0.26203	1500	7.62	4.33343	6100	30.99
0.29813	1600	8.13	4.47667	6200	31.49
0.33657	1700	8.64	4.62224	6300	32.00
0.37733	1800	9.14	4.77015	6400	32.51
0.42042	1900	9.65	4.92038	6500	33.02
0.46583	2000	10.16	5.07294	6600	33.53
0.51358	2100	10.67	5.22783	6700	34.03
0.56366	2200	11.18	5.38505	6800	34.54
0.61607	2300	11.68	5.5446	6900	35.05
0.6708	2400	12.19	5.70647	7000	35.56
0.72787	2500	12.7	5.87068	7100	36.07
0.78726	2600	13.21	6.03722	7200	36.57
0.84898	2700	13.72	6.20608	7300	37.08
0.91304	2800	14.22	6.37728	7400	37.59
0.97942	2900	14.73	6.5508	7500	38.1
1.04813	3000	15.24	6.72665	7600	38.61
1.11917	3100	15.75	6.90483	7700	39.11
1.19254	3200	16.26	7.08535	7800	39.62
1.26823	3300	16.76	7.26819	7900	40.13
1.34626	3400	17.27	7.45335	8000	40.64
1.42662	3500	17.78	7.64085	8100	41.15
1.5093	3600	18.29	7.83068	8200	41.65
1.59432	3700	18.8	8.02284	8300	42.16
1.68166	3800	19.3	8.21732	8400	42.67
1.77134	3900	19.81	8.41414	8500	43.18
1.86334	4000	20.32	8.61328	8600	43.69
1.95767	4100	20.83	8.81476	8700	44.19
2.05433	4200	21.33	9.01856	8800	44.7
2.15332	4300	21.84	9.22469	8900	45.21
2.25464	4400	22.35	9.43315	9000	45.72
2.35829	4500	22.86			

WARRANTY/DISCLAIMER

OMEGA ENGINEERING, INC. warrants this unit to be free of defects in materials and workmanship for a period of **13 months** from date of purchase. OMEGA's WARRANTY adds an additional one (1) month grace period to the normal **one (1) year product warranty** to cover handling and shipping time. This ensures that OMEGA's customers receive maximum coverage on each product.

If the unit malfunctions, it must be returned to the factory for evaluation. OMEGA's Customer Service Department will issue an Authorized Return (AR) number immediately upon phone or written request. Upon examination by OMEGA, if the unit is found to be defective, it will be repaired or replaced at no charge. OMEGA's WARRANTY does not apply to defects resulting from any action of the purchaser, including but not limited to mishandling, improper interfacing, operation outside of design limits, improper repair, or unauthorized modification. This WARRANTY is VOID if the unit shows evidence of having been tampered with or shows evidence of having been damaged as a result of excessive corrosion; or current, heat, moisture or vibration; improper specification; misapplication; misuse or other operating conditions outside of OMEGA's control. Components in which wear is not warranted, include but are not limited to contact points, fuses, and triacs.

OMEGA is pleased to offer suggestions on the use of its various products. However, OMEGA neither assumes responsibility for any omissions or errors nor assumes liability for any damages that result from the use of its products in accordance with information provided by OMEGA, either verbal or written. OMEGA warrants only that the parts manufactured by the company will be as specified and free of defects. OMEGA MAKES NO OTHER WARRANTIES OR REPRESENTATIONS OF ANY KIND WHATSOEVER, EXPRESSED OR IMPLIED, EXCEPT THAT OF TITLE, AND ALL IMPLIED WARRANTIES INCLUDING ANY WARRANTY OF MERCHANTABILITY AND FITNESS FOR A PARTICULAR PURPOSE ARE HEREBY DISCLAIMED. LIMITATION OF LIABILITY: The remedies of purchaser set forth herein are exclusive, and the total liability of OMEGA with respect to this order, whether based on contract, warranty, negligence, indemnification, strict liability or otherwise, shall not exceed the purchase price of the component upon which liability is based. In no event shall OMEGA be liable for consequential, incidental or special damages.

CONDITIONS: Equipment sold by OMEGA is not intended to be used, nor shall it be used: (1) as a "Basic Component" under 10 CFR 21 (NRC), used in or with any nuclear installation or activity; or (2) in medical applications or used on humans. Should any Product(s) be used in or with any nuclear installation or activity, medical application, used on humans, or misused in any way, OMEGA assumes no responsibility as set forth in our basic WARRANTY/DISCLAIMER language, and, additionally, purchaser will indemnify OMEGA and hold OMEGA harmless from any liability or damage whatsoever arising out of the use of the Product(s) in such a manner.

RETURN REQUESTS/INQUIRIES

Direct all warranty and repair requests/inquiries to the OMEGA Customer Service Department. BEFORE RETURNING ANY PRODUCT(S) TO OMEGA, PURCHASER MUST OBTAIN AN AUTHORIZED RETURN (AR) NUMBER FROM OMEGA'S CUSTOMER SERVICE DEPARTMENT (IN ORDER TO AVOID PROCESSING DELAYS). The assigned AR number should then be marked on the outside of the return package and on any correspondence.

The purchaser is responsible for shipping charges, freight, insurance and proper packaging to prevent breakage in transit.

FOR **WARRANTY** RETURNS, please have the following information available BEFORE contacting OMEGA:

1. Purchase Order number under which the product was PURCHASED,
2. Model and serial number of the product under warranty, and
3. Repair instructions and/or specific problems relative to the product.

FOR **NON-WARRANTY** REPAIRS, consult OMEGA for current repair charges. Have the following information available BEFORE contacting OMEGA:

1. Purchase Order number to cover the COST of the repair,
2. Model and serial number of the product, and
3. Repair instructions and/or specific problems relative to the product.

OMEGA's policy is to make running changes, not model changes, whenever an improvement is possible. This affords our customers the latest in technology and engineering.

OMEGA is a trademark of OMEGA ENGINEERING, INC. © Copyright OMEGA ENGINEERING, INC. All rights reserved. This document may not be copied, photocopied, reproduced, translated, or reduced to any electronic medium or machine-readable form, in whole or in part, without the prior written consent of OMEGA ENGINEERING, INC.



omega.com

M-1776/0624

