

**1 YEAR**  
WARRANTY



# **Ω OMEGA™** **User's Guide**



**Shop online at  
[omega.com](http://omega.com)**

**e-mail: [info@omega.com](mailto:info@omega.com)  
For latest product manuals:  
[www.omegamanual.info](http://www.omegamanual.info)**

**IP210A SERIES  
ELECTROPNEUMATIC CONVERTERS**



omega.com info@omega.com

### **Servicing North America:**

**U.S.A.  
Headquarters:**

Omega Engineering, Inc.  
Toll-Free: 1-800-826-6342 (USA & Canada only)  
Customer Service: 1-800-622-2378 (USA & Canada only)  
Engineering Service: 1-800-872-9436 (USA & Canada only)  
Tel: (203) 359-1660 Fax: (203) 359-7700  
e-mail: info@omega.com

**For Other Locations Visit [omega.com/worldwide](http://omega.com/worldwide)**

California Proposition 65

 **WARNING:** Cancer and Reproductive Harm  
[www.p65Warnings.ca.gov](http://www.p65Warnings.ca.gov)

## PRINCIPLE OF OPERATION

The transducer is a force balance device in which a coil is suspended in the field of a magnet by a flexure. Current flowing through the coil generates axial movement of the coil and flexure. The flexure moves against the end of a nozzle, and creates a back pressure in the nozzle by restricting air flow. This back pressure acts as a pilot pressure to an integral booster relay. Consequently, as the input signal increases (or decreases, for reverse acting), output pressure increases proportionally. Zero and span are calibrated by turning easily accessible adjusting screws on the front face of the unit. The zero adjustment causes the nozzle to move relative to the flexure. The span adjustment is a potentiometer that limits the flow of current through the coil. A thermistor circuit in series with the coil provides temperature compensation.

## MOUNTING

The transducer can be mounted at any angle, but should be calibrated after mounting. For maximum output pressure stability, it should be mounted vertically in a vibration free location or such that the vibration is isolated to the X and Z axis as shown in **Figure 3**.

**Pipe:** Due to its light weight, the transducer may be supported by the piping used for the supply and output.

**Panel:** (with access to rear of panel) Attach transducer (**See Fig. 3**), to panel using two 10-32 screws and two threaded mounting holes on the back of the unit.

**Panel:** (with no access to rear of panel) Attach bracket (**See Fig. 1 and 3**), to transducer using two 10-32 screws on the back of the unit and mount bracket to panel using four 8-32 screws.

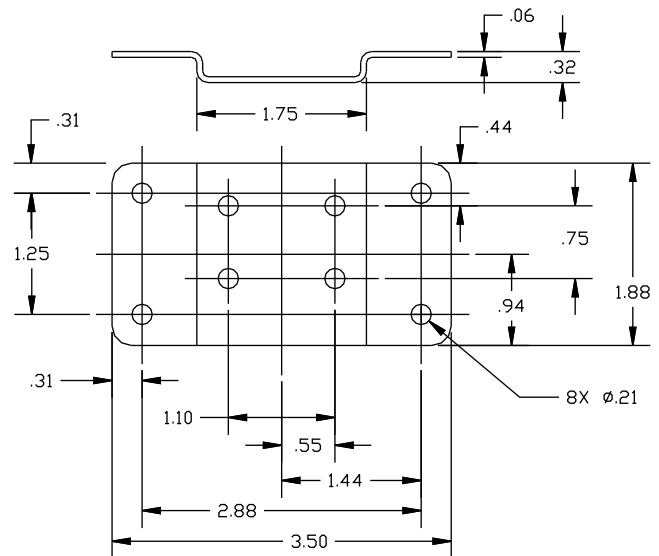

Figure 1

## AIR CONNECTIONS

- Supply Air must be instrument quality air regulated between the minimum and maximum specified on the nameplate of the transducer.
- Instrument quality air consists of:
  - a A dew point less than 35°F
  - b No particles larger than three microns
  - c Maximum oil content of 1 ppm
- All unused ports must be plugged.

**Supply:** Connect supply to the 1/4" NPT ports marked "IN" on the base of the transducer. Avoid getting pipe sealant inside the piping or transducer.

**Output:** Connect output to the 1/4" NPT ports marked "OUT" on the base of the transducer. The pipe plugs may be removed from the two auxiliary output ports for a pressure gauge or as an alternative output port.

## INSTALLATION OF THE DIN 43650A CONNECTOR

Included with the unit: Instructions & 3-Prong Connector

Tools Required: Solder, Soldering Iron & Wire Cutter/Stripper

1. Remove the outer locking ring from the male portion of the DIN 43650A connector and disassemble.
2. Run the two wires through the NPT portion of the male connector and thread the connector snugly into the ½ NPT conduit port.
3. Cut both wires (black and white) to about 1" long beyond the male NPT section that is installed on the IP210A, and trim the end to about 1/4".
4. Solder the black wire to Pin #1, and the white wire to Pin #2.
5. Insert the terminal portion into the NPT portion.
6. Position the prongs with the Safety Ground (flat prong) on the bottom. Secure with the outer ring. Do not overtighten.
7. Remove the terminal portion of the female section of the connector using a small slotted screwdriver under the slot marked "LIFT".
8. Run wires through the connector housing and secure to the appropriate terminal with a small screwdriver.  
For **DIRECT ACTING**: (where increasing the input signal increases output pressure), connect the positive input signal to Pin #1, and the negative to Pin #2.  
For **REVERSE ACTING**: (where increasing the input signal decreases output pressure), connect the positive input signal to Pin #2, and the negative to Pin #1.
9. Insert the terminal into the housing with the proper wiring orientation.
10. Orient the gasket over the prongs, and install the female portion of the connector assembly. Using a small screwdriver, secure with the locking screw.

## ELECTRICAL CONNECTIONS

### PRECAUTIONS TO BE OBSERVED DURING INSTALLATION



The Transducers were tested at the EMC Test Centre, Dunfermline, Fife, KY11 5LB to the Electromagnetic Compatibility Directive effective January 1, 1996. The relevant EMC specifications tested were the following: EN 50081-1 (1992) and EN 50082-1 (1992). A Technical Construction File, Serial #107 was written and Certificate of Conformity issued by a Competent Body.

EN 50081-1 (1992): Test results confirmed that no precautions need to be observed during installation regarding electro-magnetic emissions from the IP210A Transducers.

EN 50082-1 (1992): The following precautions should be taken during installation to maintain the advertised accuracy specifications for the Transducers. The input wiring to the transducer should be isolated from other high voltage transient wiring. The momentary switching on and off of nearby relays, motors, or other high capacitive or inductive loads can have a minor effect on the terminal based linearity specification (1.0% of span, standard range models). Any change in output pressure is minimal and momentary, and is considered to be within its performance capabilities. Use of a ferrite bead collar on the input wires entering the transducer is recommended should installation next to high electromagnetic interference be necessary.

## CALIBRATION

Once the transducer has been mounted, and air supply connections finished, the unit's calibration must be checked before placing into service. Remove rubber plugs to gain access to "ZERO" and "SPAN" adjusting screws. See Figure 3 for "ZERO" and "SPAN" locations. Re-install rubber plugs after calibration is complete.

Note: input percentage refers to the following examples:

If 4 to 20 mA	
0%	= 4 mA
25%	= 8 mA
50%	= 12 mA
75%	= 16 mA
100%	= 20 mA

### Forward Acting

1. Apply the 0% input signal to unit and adjust the "Zero" adjusting screw to the low setpoint output. Turn screw counter-clockwise to increase output. If there is no change in output, keep turning adjustment screw counter-clockwise until output begins to rise. It is imperative that the output pressure be closely monitored as turning the zero screw excessively could damage the flexure.
2. Apply the 100% signal to unit and adjust "Span" adjusting screw until output is at the high setpoint.
3. Turn the "Span" adjusting screw counter-clockwise to increase output.
4. Repeat steps 1 & 2 until unit is calibrated.

### Reverse Acting

1. Apply the 0% input signal to unit and adjust "Zero" adjusting screw until output reaches the high output pressure set-point. Turn counter-clockwise to increase.
2. Apply the 100% input signal to unit and adjust "Span" adjustment until output pressure is at the low setpoint.  
**IMPORTANT:** Turn the "Span" adjusting screw clockwise to increase output
3. Repeat steps 1 & 2 until unit is calibrated.

FIGURE 2

I / P SCHEMATIC

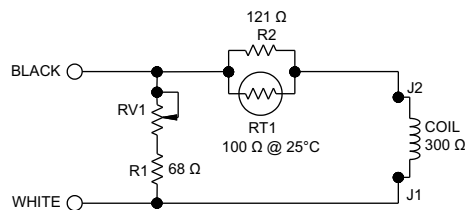

### SIGNAL IMPEDANCE

The input impedance will vary depending upon the potentiometer setting of the "SPAN (RV1)", (SEE FIG. 2). The I/P circuit design consists of a resistor and potentiometer in parallel with the coil/flexure. The following are some of the nominal impedances that would be measured across the signal leads of the average calibrated transducer. These values are helpful when determining power requirements and for troubleshooting.

INPUT SIGNAL	OUTPUT RANGE	NOMINAL IMPEDANCE (OHMS)	POTENTIOMETER RV1 SIZE (OHMS)
4-20mA	3-15 PSIG	180	1000
4-20mA	3-27 PSIG	215	1000
4-20mA	3-120 PSIG	260	1000
4-20mA	2-60 PSIG	225	1000

## TROUBLESHOOTING

SYMPTOM	CAUSE	SOLUTION
<b>Sluggish Performance or Reduced Range</b>	1) Plugged or blocked orifice.	1) Remove orifice screw and clean orifice with wire or pin <math><0.009''</math> diameter
	2) Supply pressure too low.	2) Supply pressure must be at least 5 PSIG above the 100% output.
<b>Transducer remains at start up no matter the input signal.</b>	1) Zero set too low.	1) Turn zero adjustment counter-clockwise until output pressure increases then follow calibration procedure.
	2) Electrical connection has opened or wrong type of signal applied.	2) Check electrical connections to insure that there is a correct input signal reaching the transducer.
<b>Transducer works in reverse. (Pressure goes down when input signal goes up.)</b>	Wires connected in reverse	Insure wiring is connected per Electrical Connection section.
<b>Output Pressure same as supply Pressure with no signal effect.</b>	Pneumatic connections reversed or supply and output both connected to "IN" ports.	Insure supply is connected to port marked "IN" and output is connected to port marked "OUT".

**Note:** If you experience an unusual problem that is not described in this section, or if troubleshooting procedures will not restore the unit to normal operation, please contact Omega.

**Figure 3**

IP210A Unit shown without female 43650A connector.

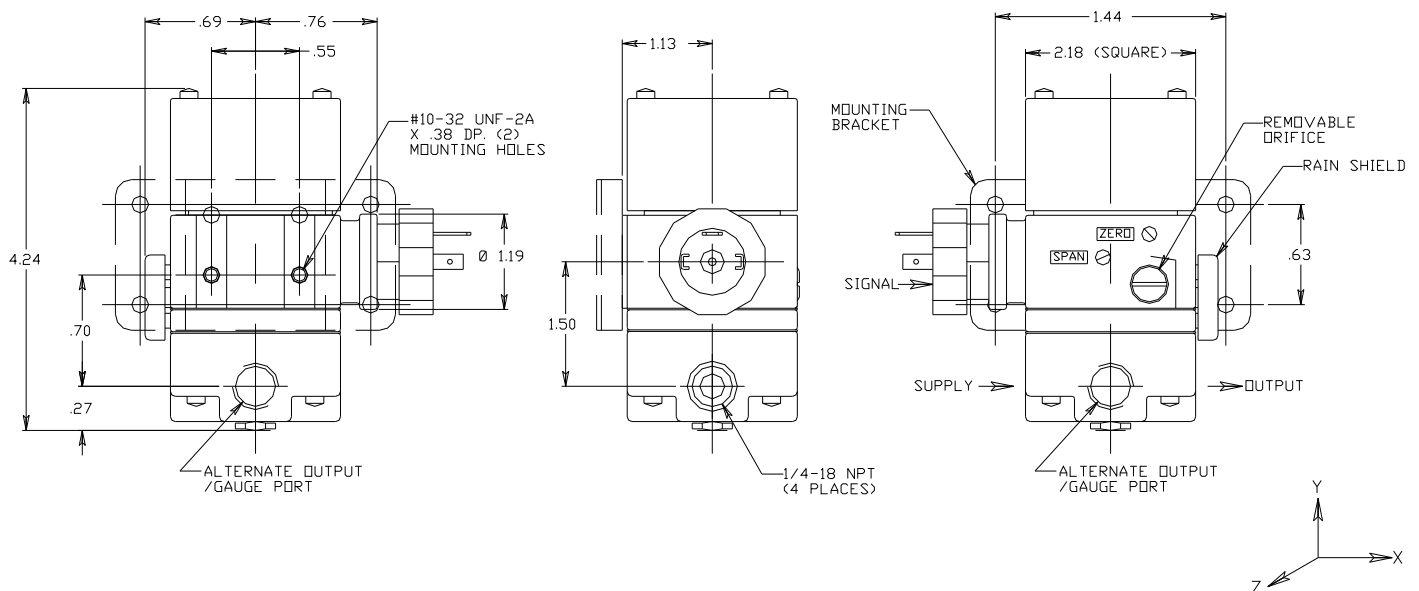

## WARRANTY/DISCLAIMER

OMEGA ENGINEERING, INC. warrants this unit to be free of defects in materials and workmanship for a period of **13 months** from date of purchase. OMEGA's WARRANTY adds an additional one (1) month grace period to the normal one (1) **year product warranty** to cover handling and shipping time. This ensures that OMEGA's customers receive maximum coverage on each product.

If the unit malfunctions, it must be returned to the factory for evaluation. OMEGA's Customer Service Department will issue an Authorized Return (AR) number immediately upon phone or written request. Upon examination by OMEGA, if the unit is found to be defective, it will be repaired or replaced at no charge. OMEGA's WARRANTY does not apply to defects resulting from any action of the purchaser, including but not limited to mishandling, improper interfacing, operation outside of design limits, improper repair, or unauthorized modification. This WARRANTY is VOID if the unit shows evidence of having been tampered with or shows evidence of having been damaged as a result of excessive corrosion; or current, heat, moisture or vibration; improper specification; misapplication; misuse or other operating conditions outside of OMEGA's control. Components in which wear is not warranted, include but are not limited to contact points, fuses, and triacs.

**OMEGA is pleased to offer suggestions on the use of its various products. However, OMEGA neither assumes responsibility for any omissions or errors nor assumes liability for any damages that result from the use of its products in accordance with information provided by OMEGA, either verbal or written. OMEGA warrants only that the parts manufactured by the company will be as specified and free of defects. OMEGA MAKES NO OTHER WARRANTIES OR REPRESENTATIONS OF ANY KIND WHATSOEVER, EXPRESSED OR IMPLIED, EXCEPT THAT OF TITLE, AND ALL IMPLIED WARRANTIES INCLUDING ANY WARRANTY OF MERCHANTABILITY AND FITNESS FOR A PARTICULAR PURPOSE ARE HEREBY DISCLAIMED. LIMITATION OF LIABILITY: The remedies of purchaser set forth herein are exclusive, and the total liability of OMEGA with respect to this order, whether based on contract, warranty, negligence, indemnification, strict liability or otherwise, shall not exceed the purchase price of the component upon which liability is based. In no event shall OMEGA be liable for consequential, incidental or special damages.**

CONDITIONS: Equipment sold by OMEGA is not intended to be used, nor shall it be used: (1) as a "Basic Component" under 10 CFR 21 (NRC), used in or with any nuclear installation or activity; or (2) in medical applications or used on humans. Should any Product(s) be used in or with any nuclear installation or activity, medical application, used on humans, or misused in any way, OMEGA assumes no responsibility as set forth in our basic WARRANTY/DISCLAIMER language, and, additionally, purchaser will indemnify OMEGA and hold OMEGA harmless from any liability or damage whatsoever arising out of the use of the Product(s) in such a manner.

## RETURN REQUESTS/INQUIRIES

Direct all warranty and repair requests/inquiries to the OMEGA Customer Service Department. BEFORE RETURNING ANY PRODUCT(S) TO OMEGA, PURCHASER MUST OBTAIN AN AUTHORIZED RETURN (AR) NUMBER FROM OMEGA'S CUSTOMER SERVICE DEPARTMENT (IN ORDER TO AVOID PROCESSING DELAYS). The assigned AR number should then be marked on the outside of the return package and on any correspondence.

The purchaser is responsible for shipping charges, freight, insurance and proper packaging to prevent breakage in transit.

FOR **WARRANTY** RETURNS, please have the following information available BEFORE contacting OMEGA:

1. Purchase Order number under which the product was PURCHASED,
2. Model and serial number of the product under warranty, and
3. Repair instructions and/or specific problems relative to the product.

FOR **NON-WARRANTY** REPAIRS, consult OMEGA for current repair charges. Have the following information available BEFORE contacting OMEGA:

1. Purchase Order number to cover the COST of the repair,
2. Model and serial number of the product, and
3. Repair instructions and/or specific problems relative to the product.

OMEGA's policy is to make running changes, not model changes, whenever an improvement is possible. This affords our customers the latest in technology and engineering.

OMEGA is a registered trademark of OMEGA ENGINEERING, INC.

© Copyright 2017 OMEGA ENGINEERING, INC. All rights reserved. This document may not be copied, photocopied, reproduced, translated, or reduced to any electronic medium or machine-readable form, in whole or in part, without the prior written consent of OMEGA ENGINEERING, INC.

# Where Do I Find Everything I Need for Process Measurement and Control? **OMEGA...Of Course!** Shop online at [omega.com](http://omega.com)

## **TEMPERATURE**

Thermocouple, RTD & Thermistor Probes, Connectors, Panels & Assemblies  
Wire: Thermocouple, RTD & Thermistor  
Calibrators & Ice Point References  
Recorders, Controllers & Process Monitors  
Infrared Pyrometers

## **PRESSURE, STRAIN AND FORCE**

Transducers & Strain Gages  
Load Cells & Pressure Gages  
Displacement Transducers  
Instrumentation & Accessories

## **FLOW/LEVEL**

Rotameters, Gas Mass Flowmeters & Flow Computers  
Air Velocity Indicators  
Turbine/Paddlewheel Systems  
Totalizers & Batch Controllers

## **pH/CONDUCTIVITY**

pH Electrodes, Testers & Accessories  
Benchtop/Laboratory Meters  
Controllers, Calibrators, Simulators & Pumps  
Industrial pH & Conductivity Equipment

## **DATA ACQUISITION**

Communications-Based Acquisition Systems  
Data Logging Systems  
Wireless Sensors, Transmitters, & Receivers  
Signal Conditioners  
Data Acquisition Software

## **HEATERS**

Heating Cable  
Cartridge & Strip Heaters  
Immersion & Band Heaters  
Flexible Heaters  
Laboratory Heaters

## **ENVIRONMENTAL MONITORING AND CONTROL**

Metering & Control Instrumentation  
Refractometers  
Pumps & Tubing  
Air, Soil & Water Monitors  
Industrial Water & Wastewater Treatment  
pH, Conductivity & Dissolved Oxygen Instruments