



Series EDA Electronic Pressure Controller

Specifications - Installation and Operating Instructions



TABLE OF CONTENTS

Dimensions	1
Specifications	2
Model Chart	3
Display	3
Installation Instructions	4-5
Unpacking and Mounting	4
Electrical Connections	5
Operating Instructions	6-18
Front Panel Functions	6
Set Points & Alarms	7-8
Alternation (Lead/Lag) Operation	8
Programming Chart	9-11
Main Menu Selections	12
Menus and Values	12-18
Security Menu	12
Operation Menu	13
Output Menu	14-15
Display Menu	16
Advanced Menu	16
Test Menu	17
Failsafe Menu	17
Diagnostic Error Messages	18
Warranty Information	18

DIMENSIONS

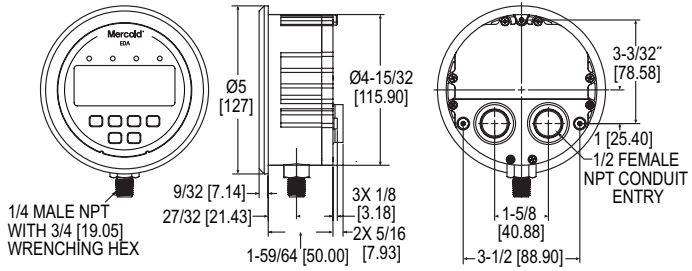

SPECIFICATIONS

Service: Compatible liquids and gases.

Wetted Materials: 316 L SS.

Housing: Polycarbonate.

Accuracy: ±1% of FS including linearity, hysteresis, and repeatability (indicator and transmitter).

Stability: < ±2% of FS per year.

Pressure Limits: Ranges up to 6,000 psi: 1.5 x range; 8,000 psi range: 10,000 psi.

Temperature Limits: Ambient: 20 to 140°F (-6.6 to 60°C); Process: 0 to 176°F (-18 to 80°C).

Compensated Temperature Limits: 32 to 122°F (0 to 50°C).

Thermal Effect: ±0.05% of FS/°F.

Process Connection: 1/4" NPT male, 1/4" BSPT male, or 7/16" SAE.

Display: 4-digit backlit LCD (Digits: 0.60" H x 0.33" W).

Display Update: 600 ms (dampening set to 1).

Power Requirements: 12-28 VDC (==) / AC (~) 50/60 Hz. (Can work at 8 VDC (==) for 45 s). For T5 option: 14-30 VDC (==) / AC (~) 50/60 Hz. For -HV option: 120-240 VAC.

Power Consumption: 12-28 VDC/VAC: 2.5 watts; 120-240 VAC: 4.5 watts.

Electrical Connections: Removable terminal blocks with two 1/2" female NPS conduit connections.

Enclosure Rating: Weatherproof type 4X IP65 (IP65 not evaluated by UL).

Warm Up Time: <10 s.

Mounting Orientation: Any position.

Weight: 1.18 lbs (535 g).

Installation Category: II (transient over-voltage).

Pollution Degree: 2.

Altitude Limit: 6560 ft (2000 m) max.

Environment: Intended for indoor and outdoor use.

Humidity: 0 to 95% RH up to 104°F (40°C) non-condensing, 10 to 50% at 140°F (60°C) non-condensing.

SWITCH SPECIFICATIONS

Switch Type: 2 SPDT relays.

Electrical Rating: 5A @ 120/240 VAC (~) 50/60 Hz, 1A @ 28 VDC (==).

Repeatability: ±1% of FS (switching only).

Set Points: Adjustable 0-100% of FS.

Switch Indication: External LED for each relay on the front panel.

Switch Reset: Manual or automatic.

TRANSMITTER SPECIFICATIONS

Output Signal: 4-20 mA, 1-6 VDC (==), 1-5 VDC (==), 0-5 VDC (==), or 0-10 VDC (==)(direct or reverse output selection).

Minimum Excitation: 14 VDC (==).

Zero and Span Adjustments: Menu scalable within the range.

MODEL CHART								
Example	EDA	W	-N1	E1	-01	T0	-NIST	EDAW-N1E1-01T0-NIST
Series	EDA							Electronic pressure controller
Housing		W						Weatherproof
Process Connection			N1					1/4" male NPT
Conduit Connection				E1				Two 1/2" NPT
Range					02 03 04 05 06 07 08 09 10			0-20 psig 0-60 psig 0-100 psig 0-150 psig 0-300 psig 0-600 psig 0-1000 psig 0-1500 psig 0-3000 psig
Transmitter Output						T0 T1 T2 T3 T4 T5		None 4-20 mA 1-5 VDC 0-5 VDC 1-6 VDC 0-10 VDC
Options							AT HV NIST	Stainless steel tag 120-240 VAC power NIST certificate

Display

The EDA has two displays: a lower larger display and a smaller upper display. The Home Display is the normal display while the control is in operation if there are no errors or functions active. The Home display will indicate the process variable at the current condition with the lower display and the selected pressure units for the process variable with the upper display. When programming the unit both displays are also used. The Programming Chart in this instruction manual indicates what both displays show while programming the unit. For programming descriptions in this instruction manual the format used is "lower display – upper display". For example Ctrl – 1SP shows that Ctrl would be in the lower display and 1SP would be in the upper display.

When the user presses the E key to edit an item's value the upper display will flash "EDIT" and the lower display will blink. When the user presses the E key to then save the edit to the value the upper display will flash "SAVE" and the lower display will stop blinking.

1.0 INSTALLATION

1.1 UNPACKING

Remove the EDA from the shipping carton and inspect for damage. If damage is found, notify the carrier immediately.

1.2 MOUNTING

The EDA can be pipe, panel, or surface mounted. For pipe mounting thread the unit into a mating female fitting on the pipe. Use a wrench on the 3/4" hex at the base of the housing to tighten the unit to the mating fitting. Do not thread the unit in by force on the housing. For panel mounting, insert the unit into the panel opening and secure in place with the machine screws and adapters provided with the unit as shown in Figure 1 below. Maximum panel thickness is 1/8" (3.5 mm) with supplied screws. For surface mounting, panel mount the unit into the A-EDA-BRK mounting bracket (See the Dwyer catalog or website for ordering details) also shown in Figure 1. The unit can also be directly surface mounted, as shown in Figure 2, with the proper panel cutout for the conduit entrances. Support the pressure connection hex with a wrench if attaching a fitting to the unit in the case of panel or flush mounting so that the pressure connection does not twist. Use a small amount of plumber's tape or other suitable sealants to prevent leaks around fitting.

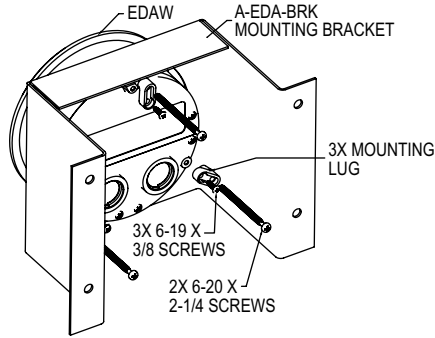

Figure 1: Panel mounting and mounting in A-EDA-BRK bracket

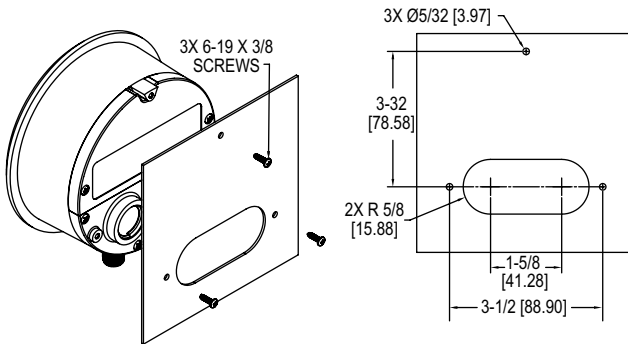

Figure 2: Surface mounting

1.3 ELECTRICAL CONNECTIONS

⚠ DANGER

ELECTRIC SHOCK HAZARD. DISCONNECT POWER BEFORE MAKING ELECTRICAL CONNECTIONS. Failure to do so will result in injury or death.

CAUTION

EQUIPMENT DAMAGE. Do not exceed the specified supply voltage rating. Failure to do so may result in permanent equipment damage.

CAUTION

EQUIPMENT DAMAGE. Do not allow wire to touch or press on PCBA components when fishing wire through the conduit connection. Failure to do so may result in damage to the circuitry.

NOTICE

To maintain Type 4X rating of the enclosure, 1/2 NPT conduit fittings must have a UL Type 4X outdoor rating.

Note: Installation must be made in accordance with local codes and regulations.

Electrical connections are made to the removable terminal blocks inside the enclosure. Remove the top back cover, do not remove bottom cover. Feed stripped and tinned leads through the conduit opening and connect them as shown in Figure 3. The EDA provides two 1/2" NPT female ports for conduit connection. The conduit connections must be made such that condensation is not allowed to enter the sensor housing. If necessary install a conduit breather drain in a separate conduit body to prevent buildup of moisture. It is recommended that shielded twisted pair wire be used for the transmitter output option if the potential exists for interference from external noise sources. When replacing top back cover tighten screws to 2 ±.25 in lbs.

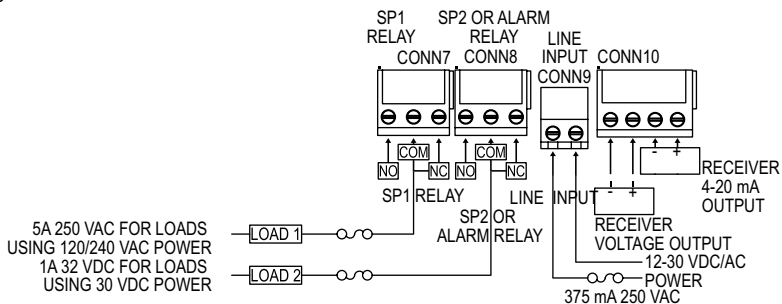

Figure 3: Wiring

An external power supply of 12-28 VDC/AC with minimum current capability of 200 mA must be used to power the unit (-HV option must be 120-240 VAC). The power supply connection is not polarity sensitive so the positive and negative connections may be made to either terminal of CONN9 terminal block.

For voltage output option, connect the voltage receiver (-) to terminal 1 and voltage receiver (+) to terminal 2 of the CONN10 terminal block. For current output option, connect the current receiver (-) to terminal 3 and current receiver (+) to terminal 4 of CONN10 terminal block. **DO NOT APPLY EXTERNAL POWER TO CONN10 TERMINALS - PERMANENT DAMAGE NOT COVERED BY WARRANTY WILL RESULT.**

Loads can be connected to connectors CONN7 and CONN8 terminal blocks based on the Control settings:

- For single set point mode (**CtrlL-1SP**), connect the Load to **SP1** relay (CONN7).
- For two set points mode (**CtrlL-2SP**), connect the Load1 to **SP1** relay (CONN7) and Load2 to **SP2** relay (CONN8).
- For single set point and alarm mode (**CtrlL-SPAL**), connect the Load1 to **SP1** relay (CONN7) and Load2 to **ALARM** relay (CONN8).

Wiring

An external switch or circuit breaker should be added to during the installation as a disconnecting device. The switch or circuit breaker must meet the requirements of IEC 60947-1 and IEC 60947-3, shall disconnect all current carrying conductors, and shall not interrupt the protective earth ground. The disconnecting switch or circuit breaker must be marked or labeled with the symbols "I" for on and "O" for off, per IEC 60417-5007 & IEC 60417-5008 and shall be marked as "Disconnecting Device". Do not position the EDA in a space where it is difficult to operate the disconnecting device that provides power. 300 V 18 AWG/0.75 mm² wiring with PVC or equivalent insulation with 94-V0 or FV-0 flammability rating is recommended for the switch outputs and power. Use only copper wire rated to 60°C minimum. Terminal blocks rated for 16-22 solid or stranded copper conductor. 6 lb in is suggested tightening torque.

NOTICE

As a permanently installed piece of equipment, a power disconnect switch, circuit breaker, or other approved disconnect device must be installed in close proximity to the installed board and within easy reach of the operator. This disconnect device must include a label indicating its function as a

mains disconnect. A circuit breaker or fuse device is recommended (see Figure 3).

Explanation of Symbols:

Symbol	Publication	Description
— —	IEC 50417 - 5031	Direct current
~	IEC 50417 - 5032	Alternating current
⊕	IEC 50417 - 5019	Protective conductor terminal
	IEC 50417 - 5007	On (supply)
○	IEC 50417 - 5008	Off (supply)

2. OPERATING INSTRUCTIONS

2.1 FRONT PANEL & KEY FUNCTIONS

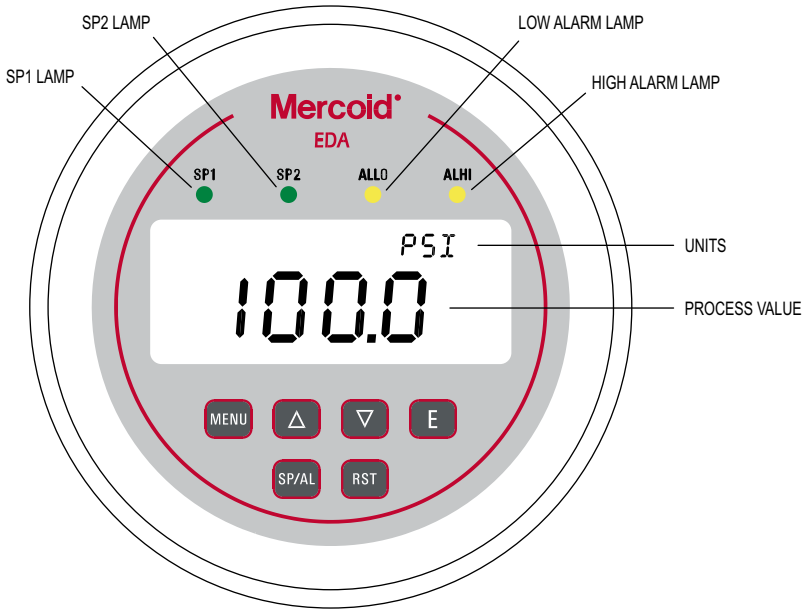

Figure 4: Front panel functions

KEY FUNCTIONS			
	Home Position Function	Main Menu Function	Item Function
SP/AL	Sequences the display through SET POINT and ALARM settings	Return to home position	Return to home position
MENU	Allows access to menus	Return to home position	Return to previous menu
UP ARROW		Sequences through menus	Increments a value
DOWN ARROW		Sequences through menus	Decrements a value
ENTER	Displays full scale range of unit	Enter into items	Changes a value or setting. Press Enter and display will blink. Adjust with UP or DOWN arrows. Press ENTER to store. Display will stop blinking.
RESET	Clears or resets an Alarm (alarm set for manual reset)		Peak/Valley resets display to present value.

2.2 SET POINTS AND ALARMS

Setting Set Points and Alarms

CONTROL MODE

1SP

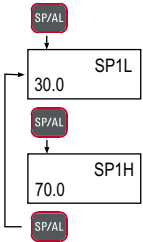

CONTROL MODE

2SP

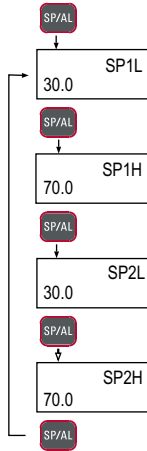

CONTROL MODE

SPPL

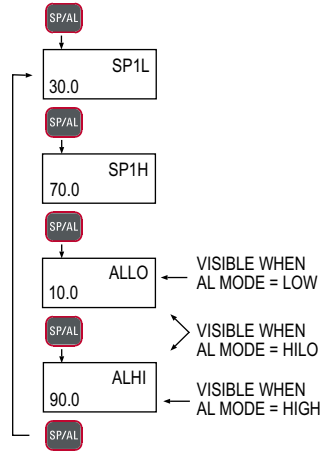

Set Point Adjustment

Adjusting the set points is quick and simple. Instead of setting a set point and dead band, simply adjust SP1H, Set Point 1 High, and SP2H, Set Point 2 High, for the desired relay turn on point, and then adjust SP1L, Set Point 1 Low, and SP2L, Set Point 2 Low, for the desired relay turn off point.

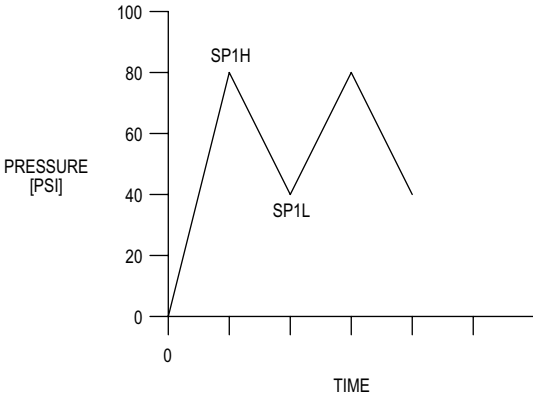

In the above graph, an instrument with a 100 psi range would have the **SP1** relay turn ON at 80 psi and OFF at 40 psi. **SP1H** sets the relay turn ON point, and **SP1L** sets the relay turn OFF point.

Relay Action

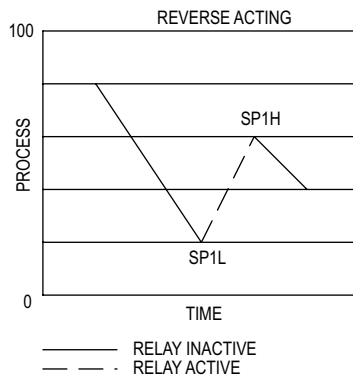
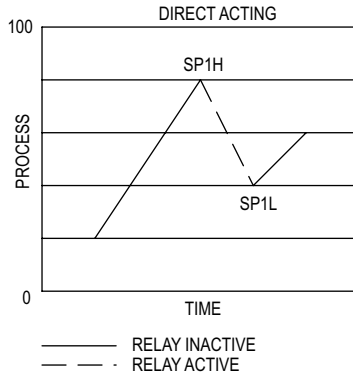

The relays outputs normally function in the direct acting mode, which means the relays turn ON with an increase in pressure. **SP1** and **SP2** may be configured to act as reverse acting relays (refer to the **CtrlL** menu item). When set for reverse acting, **SP1H** and **SP2H** set the relay turn OFF point, and **SP1L** and **SP2L** set the relay turn ON point. The above graph demonstrates direct and reverse action on process (pressure) change.

Alternating (Lead/Lag) Operation

The EDA is designed to easily operate a pair of pumps in an alternating operation to minimize pump wear. The unit has programmable on and off set points for pump one and two. If the lead/lag feature is turned off then the relays remain attached to their corresponding set points, **SP1H** and **SP1L** control relay 1 (pump 1) and **SP2H** and **SP2L** control relay 2 (pump 2). There is no alternating function.

If lead/lag feature is turned on then the relays will alternate with set points **SP1H** and **SP1L** to **SP2H** and **SP2L** with every cycle of set points. The Last relay turned off will be last relay turned on with the next cycle. On the first cycle on increase of pressure, assuming direct acting, the **SP1** relay (pump 1) will come on and then on further increase of pressure the **SP2** relay (pump 2) will come on. On the subsequent decrease of pressure the **SP2** relay (pump 2) will come off and then the **SP1** relay (pump 1) will come off. When pressure increases on the next cycle the relay used on the last cycle for **SP2** will now be used for **SP1**, so that **SP1** now controls pump 2 and **SP2** now controls pump 1. Even if **SP2** is not used on the pressure cycle the relays still alternate on next cycle.

2.3 PROGRAMMING CHART

MENU MAP

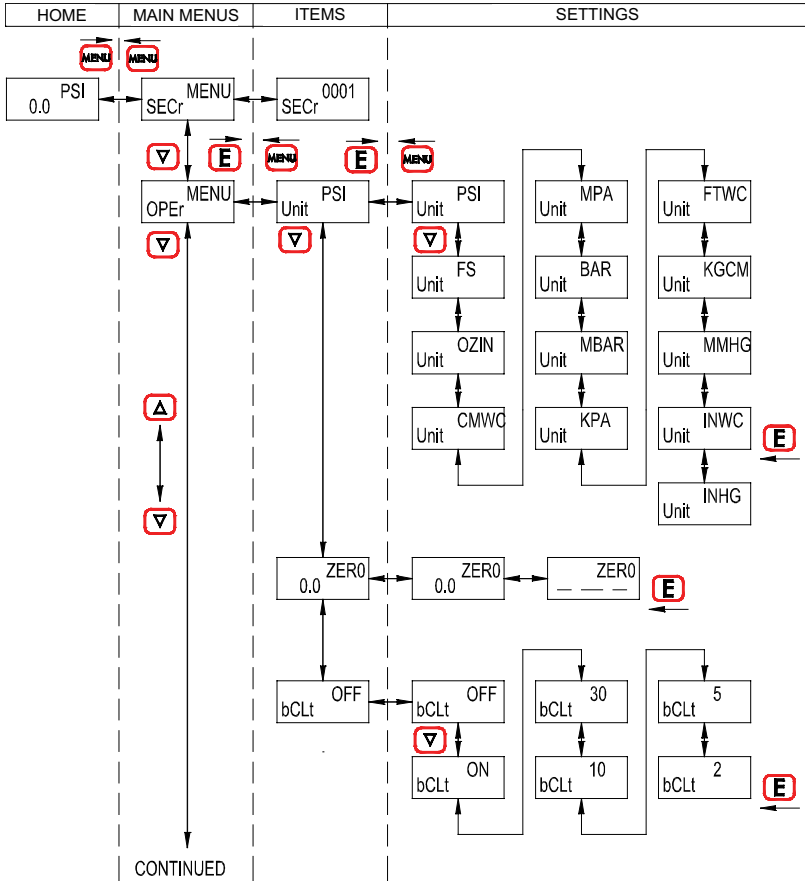

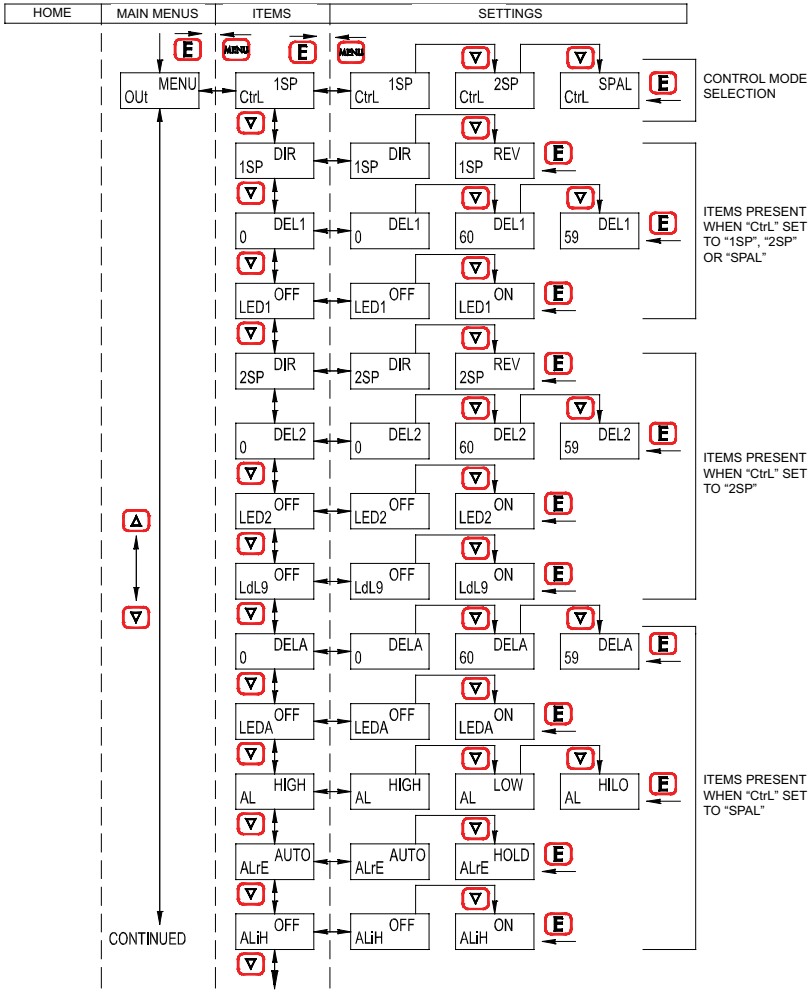

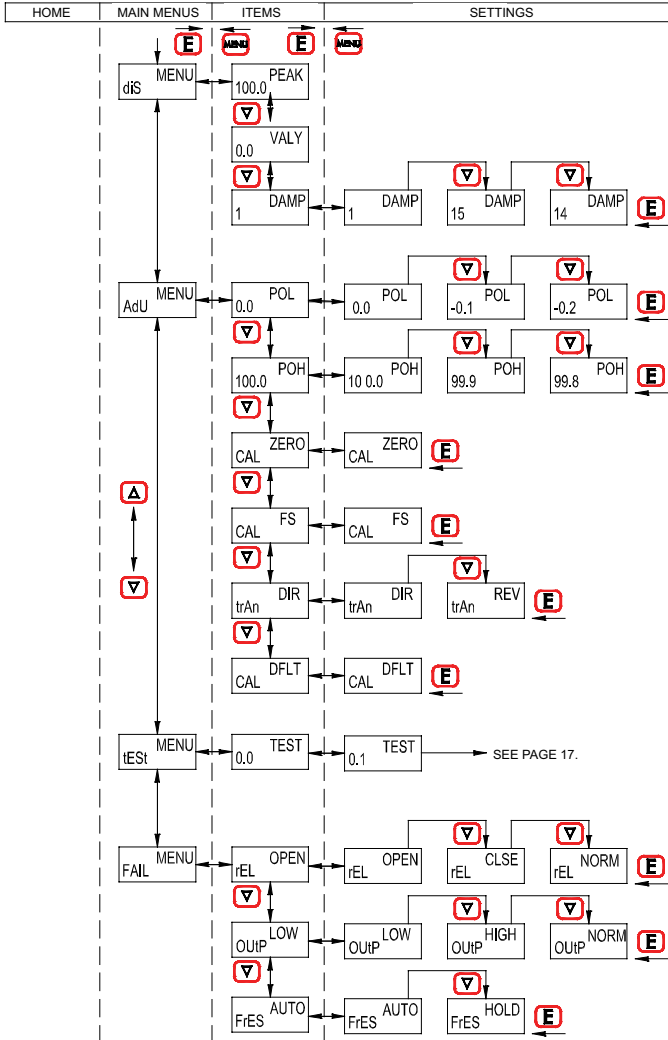

2.4 MAIN MENU SELECTIONS

Menu Selections

Press the **MENU** button to start the menu so that the upper right displays reads **MENU**. Press the **▼** key to advance to the next menu item. You can press the **▲** key to go back to the previous menu. Press the **E** key to enter a menu.

- SECr** Security Menu
Lock out access to set point and alarm settings, or lock out access to all settings.
- OPeR** Operation Menu
Select pressure units, zero the display, and turn the backlight on or off.
- Out** Output Menu
Select relay mode of operation, alternating function, time delay, and lamp indication.
- diS** Display Menu
Monitor and adjust display related settings: Peak, Valley and Dampening.
- AdU** Advanced Functions Menu
Modify advanced function parameters: transmitter output scaling, direct or reverse output setting, calibration, or restoring factory default calibration.
- tEst** Test Menu
Simulate input over the range without pressure to test switch and transmitter output function.
- FAIL** Failsafe Menu
Set the relay and transmitter outputs to certain preset values when failsafe conditions occur. Error codes will show on the display indicating the problem. User chooses if relay is de-energized, energized, or no action taken. With transmitter option, user chooses an output of 3.6 mA, 22 mA, or no action taken.

Menus and Values

- SECr** Security Menu
- SECr** When the security item is selected, the present security level is displayed in the upper right hand display. To change the security level, adjust the number displayed to the password value in the Password Table, shown below, by pressing the **▲** or **▼** key and then pressing the E key at the desired security level.

Security Level Displayed	Access	Password Value to Enter
1	All menu access	10
2	Menu access SP/AL locked	70
3	SP/AL access Menus locked	90
4	All settings locked	111

The password values shown in the table cannot be altered, so retain a copy of these pages for future reference.

OPeR Operation Menu

Unit Pressure Units

With the display reading Unit - PSI, press the E key. The upper display will blink. Press the ▼ key to change unit then press E key to save the new unit.

PSI Pounds per square inch
FS % of full scale
OZIN Ounces per square inch
CMWC Centimeters of water column
MPA Megapascals
BAR Bar
MBAR Millibar
KPA Kilopascals
FTWC Feet of water column
KGCM Kilograms per square centimeter
MMHG Millimeters of mercury
INWC Inches of water column
INHG Inches of mercury

Pressure Range vs. Available Units

PSI	KG/CM2	BAR	INHg	FTWC	KPA	MPA	INWC	MBAR	CMWC	MMHg	OZ/IN2	% FS
-14.70	-1.033	-1.013	-29.93	-33.94	-101.4	-0.101	-407.3	-1013	-1034	-761	-235.2	100
20.00	1.406	1.379	40.7	46.1	137.9	0.1379	554	1379	1406	1035	320.0	100
60.0	4.22	4.14	122.2	138.4	414	0.414	1663			3105	960	100
100.0	7.03	6.89	203.6	230.7	689	0.689	2771				1600	100
150.0	10.55	10.34	305.4	346.0	1034	1.034					2400	100
300.0	21.09	20.68	611	692	2068	2.068						100
600	42.2	41.4	1222	1384		4.14						100
1000	70.3	68.9	2036	2307		6.89						100
1500	105.5	103.4	3054	3460		10.34						100
3000	210.9	206.8				20.68						100
6000	422	414				41.4						100
8000	562	551				55.1						100

ZERO Auto Zero

Note: DO NOT apply any pressure when performing this function. With the display reading **xx - ZERO**, press the E key. The upper display will blink. Press E again to zero the display. The display will read 0.0 if the zero offset is less than ±5% of full-scale.

bCLt Backlight

ON Backlight always on.
OFF Backlight always off.
30 Backlight stays on for 30 minutes.
10 Backlight stays on for 10 minutes.
5 Backlight stays on for 5 minutes.
2 Backlight stays on for 2 minutes.

OUT Output Menu

Ctrl	Control Mode
1SP	Single set point.
2SP	Two fully independent set points.
SPAL	Single set point and alarm.
1SP	SP1 , Set Point 1, Reverse or Direct Acting
DIR	Direct. Relay turns on with increasing pressure.
REV	Reverse. Relay turns on with decreasing pressure.
DEL1	SP1 , Set Point 1, Time Delay Sets the amount of time a set point condition must be continuously met before the set point condition is recognized. The DEL1 delay is adjustable from 0-60 seconds.
LEd1	SP1 , Set Point 1, Lamp
OFF	The SP1 LED on the front panel turns OFF when the SP1 relay turns OFF. The SP1 LED on the front panel turns ON when the SP1 relay turns ON.
ON	The SP1 LED on the front panel turns ON when the SP1 relay turns OFF. The SP1 LED on the front panel turns OFF when the SP1 relay turns ON.
The following SP2 function values are only activated when Ctrl is set to 2SP :	
2SP	SP2 , Set Point 2, Reverse or Direct Acting
DIR	Direct. Relay turns on with increasing pressure.
REV	Reverse. Relay turns on with decreasing pressure.
DEL2	SP2 , Set Point 2, time delay Sets the amount of time a set point condition must be continuously met before the set point condition is recognized. The DEL2 delay is adjustable from 0-60 seconds.
LEd2	SP2 , Set Point 2, Lamp
OFF	The SP2 LED on the front panel turns OFF when the SP2 relay turns OFF. The SP2 LED on the front panel turns ON when the SP2 relay turns ON.
ON	The SP2 LED on the front panel turns ON when the SP2 relay turns OFF. The SP2 LED on the front panel turns OFF when the SP2 relay turns ON.
LdL9	Relay Alternation (See page 8)
OFF	There is no alternating function.
ON	Relays will alternate with set points SP1H/L and SP2H/L with every cycle of set points. 2SP control mode only.

The following alarm function menu items are activated when **CtrlL** is set to **SPAL**:

- DELA** Alarm Delay
Sets the amount of time an alarm condition must be continuously met before the alarm condition is recognized. The alarm delay is adjustable from 0 - 60 seconds.
- LEdA** Alarm Lamps
OFF The **ALLO** LED or **ALHI** LED on the front panel turns OFF when the alarm relay turns OFF.
 The **ALLO** LED or **ALHI** LED on the front panel turns ON when the alarm relay turns ON.
ON The **ALLO** LED or **ALHI** LED on the front panel turns ON when the alarm relay turns OFF. The **ALLO** LED or **ALHI** LED on the front panel turns OFF when the alarm relay turns ON.
- AL** Alarm Type (see Alarm Adjustment below)
HIGH High alarm only.
LOW Low alarm only.
HILO For a high and low guard band type alarm. Share the same relay output.

Alarm Adjustment

Alarm settings are dependent upon the selected alarm type. The EDA pressure controller alarm may be configured as a High Alarm, Low Alarm, or High/Low Alarm. Alarm settings may be set to anywhere within the range of the instrument. The dead bands of the alarms are fixed at 1% of full scale.

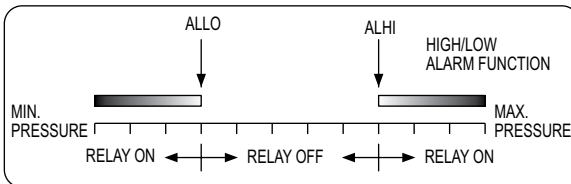
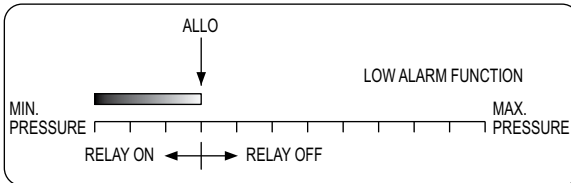
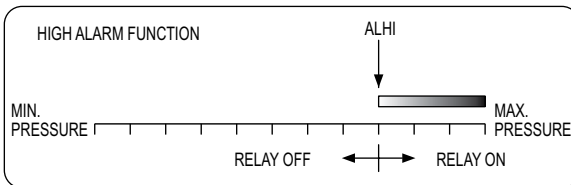

- ALrE** Alarm Reset
AUTO Automatic reset.
HOLD Manual reset. An alarm is reset by pressing the **RST** key on the front panel.

- ALiH** Low Alarm Inhibit
OFF Alarm inhibit is off.
ON Alarm inhibit is on.

Note: If **ALiH** is selected **ON**, a low alarm condition is suspended upon power up until the process value passes through the alarm set point once.

diS Display Menu

- PEAK** Peak
The Peak feature stores the highest pressure reading the instrument has measured since the last reset or power up. At power up **PEAK** is reset to the present pressure reading. To manually reset the **PEAK** value, press the **RST** (RESET) key while in **PEAK**.
- VALY** Valley
The Valley feature stores the lowest pressure reading the instrument has measured since the last reset or power up. At power up **VALY** is reset to the present pressure reading. To manually reset the **VALY** value, press the **RST** (RESET) key while in **VALY**.
- DAMP** Dampening
Adjust from 1-15. Dampening stabilizes the display from instabilities due to things such as vibration and excessive pressure fluctuations. The dampening setting adjusts the amount of readings that are averaged for each display update. Adjust the dampening value until the display reads a stable value for the application.

AdU Advanced Menu

POL, Process Output Low, and **POH**, Process Output High are used to scale the transmitter output for a unit with the output option of 4-20 mA, 0-5 VDC, 0-10 VDC, 1-5 VDC, or 1-6 VDC. Below shows with 4-20 mA output option.

- POL** Process Output Low
Set to the desired display reading for the 4 mA output. May be set from 2% below minimum scale up to **POH**.
- POH** Process Output High
Set to the desired display reading for the 20 mA output. May be set from **POL** to 2% above maximum scale.
- CAL – ZERO** Zero Calibration
DO NOT apply any pressure when performing this function. With the display reading **CAL - ZERO**, press the **E** key. The upper display will blink. Press the **E** key again to complete the zeroing of the instrument or press the **MENU** key to cancel.

- CAL – FS** Full-scale Calibration
With the display reading **CAL - FS**, apply full-scale pressure to the unit, press the **E** key. The upper display will blink. Press the **E** key again to complete the calibration or press the **MENU** key to cancel.

trAn sets the transmitter output option function for a unit with the output option of 4-20 mA, 0-5 VDC, 0-10 VDC, 1-5 VDC, or 1-6 VDC. Below shows with 4-20 mA output option.

- trAn**
- DIR** Direct Output. 4 mA output at zero, 20 mA output at full scale pressure.
REV Reverse Output. 20 mA output at zero, 4 mA output at full scale pressure.

- CAL - DFLT** Factory Default Calibration
With the display reading **CAL - DFLT**, press the **E** key. The upper display will blink. Press **E** again to restore the original factory calibration values or press the **MENU** key to cancel.

tESt Test Menu

tESt When selected the unit simulates a pressure input over the range to test the programming and output function. To start an automatic simulated cycling through the pressure range press the **E** key. This test will run continually until the **E** key is pressed again. To manually adjust the simulated pressure press the **▲** or **▼** key to adjust the pressure value. To exit **tESt** press the **MENU** key.

FAIL Failsafe Menu

The Failsafe menu is used to set the relay and transmitter outputs to certain preset values when failsafe conditions occur. Error codes will show on the display indicating the problem. See Diagnostic Error Messages on the next page.

rEL Relay Output Failsafe Condition

- OPEN** The relay is de-energized upon failsafe condition. The NO contacts will be opened, and the NC contacts will be closed.
- CLSE** The relay is energized upon failsafe condition. The NO contacts will be closed, and the NC contacts will be opened.
- NORM** No change applied to the relay upon failsafe condition.

OUTP sets the transmitter output option failsafe condition for a unit with the output option of 4-20 mA, 0-5 VDC, 0-10 VDC, 1-5 VDC, or 1-6 VDC. See below chart of transmitter output action according to output signal type.

OUTP Transmitter Output Failsafe Condition

- LOW** Transmitter output goes to low failsafe condition.
- HIGH** Transmitter output goes to high failsafe condition.
- NORM** No change applied to transmitter output upon failsafe condition.

Output Signal	4-20 mA	0-5 VDC	0-10 VDC	1-6 VDC	1-5 VDC
LOW	3.6 mA	-0.125 VDC	-0.250 VDC	0.875 VDC	0.9 VDC
HIGH	22 mA	5.625 VDC	11.250 VDC	6.625 VDC	5.5 VDC

FrEs Failsafe reset

- AUTO** Automatic reset - Failsafe is reset automatically when the failsafe error condition is removed.
- HOLD** Manual reset - Failsafe is reset when the **MENU** key is pressed.

4. DIAGNOSTIC ERROR MESSAGES

Display	Meaning
Err1	<u>Low temperature limit</u> A temperature below 0°F has been applied to the sensor
Err2	<u>High temperature limit</u> A temperature above 180°F has been applied to the sensor
Err3	<u>Sensor failure</u> The micro-controller is receiving invalid signal from the sensor
Err4	<u>Over pressure limit</u> Proof pressure have been exceeded
Err5	Keypad short

5. MAINTENANCE/REPAIR

Upon final installation of the Series EDA, inspect and clean with water or damp cloth at regular intervals. The Series EDA is not field serviceable and should be returned if repair is needed (field repair should not be attempted and may void warranty).



This symbol indicates waste electrical products should not be disposed of with household waste. Please recycle where facilities exist. Check with your Local Authority or retailer for recycling advice.

6. WARRANTY/RETURN

Refer to "Terms and Conditions of Sales" in our catalog and on our website. Contact customer service to receive a Return Goods Authorization number before shipping the product back for repair. Be sure to include a brief description of the problem plus any additional application notes.