



ADJUSTABLE SWITCHES SERIES

Installation & Operation Instructions

Part # A/ACS2, A/ACSX2, A/ASCS2, A/ASCS2-L, A/ASCSX2

Phone: 1-888-967-5224

Website: workaci.com

PRECAUTIONS

- This product is not intended to be used for Life or Safety applications.
- This product is not intended for use in any hazardous or classified locations.
- The A/ACS2, A/ACSX2, A/ASCS2 & A/ASCSX2 Series Adjustable Switches must be used on Insulated Conductors Only.

HIGH VOLTAGE

- Disconnect and lock out all power sources before installation as severe injury or death may result from electrical shock due to contact with high voltage wires.
- Never rely on the Red LED to determine whether power is present at the current switch. At very low monitored input currents the Red LED may not light to indicate the current is above the trip point.

GENERAL INFORMATION

The Adjustable Current Switches are designed for use in any AC current monitoring application in which you are looking to monitor a particular piece of equipment for equipment failure, preventative maintenance, status, and electrical load status. The current switches should be installed on the line side of the power to the electrical equipment. The current switches are available in both solid and split-core versions which also includes a Patented 35 mm Din Rail mounting foot for easy installation in panel mount applications. The adjustable current switch can be used to determine the run time of your equipment as well as basic load trending applications where you want to know when how long your piece of equipment runs when logging the contact closures on your building management system or PLC.

The current switches will not require external power because the power for the current switch is induced from the conductor being monitored.

INSTALLATION

Ensure all installations are in compliance with all national and local electrical codes. Only qualified individuals that are familiar with codes, standards, and proper safety procedures for high-voltage installations should attempt installation. The current switches will not require external power because the power for the current switch is induced from the conductor being monitored.

FIGURE 1: DIMENSIONS

Solid-Core

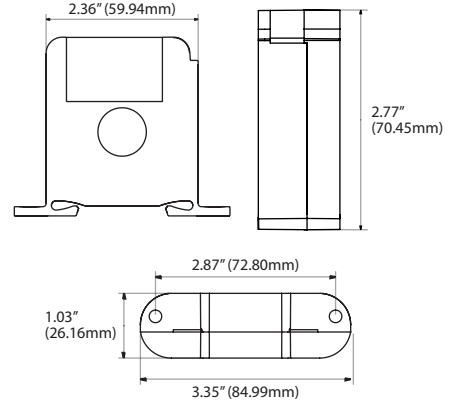

Split-Core

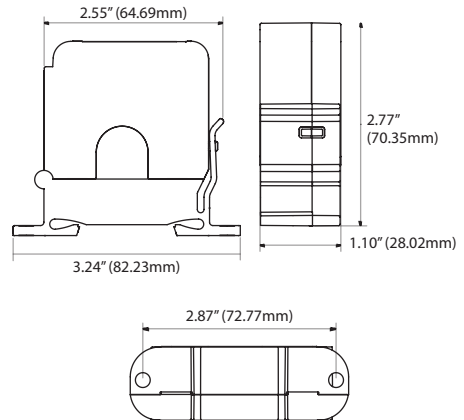

The current switch may be mounted in any position using the two #8 x 3/4" Tek screws and the mounting holes in the base, or snapped directly on to the 35mm DIN rail (See **Figure 3**). Leave a minimum distance of 1" (3 cm) between the current switch and any other magnetic devices such as contactors and transformers.

Latch Operation for A/ASCS2 Series

Press down on the side tab and swing the top of the unit up to open the split core current switch as shown in **Figure 2**. Press down firmly on the cover to close the current switch. An audible "click" will be heard as the tab slides over the tongue on the base.

CAUTION: Mating surfaces of the magnetic core are exposed when the sensor is open. Electrical contact grease, present on the cores to prevent corrosion, can capture grit and dirt if care is not exercised. Operation can be impaired if anything prevents good contact between pole pieces. Visually check the mating parts of the core before closing the current sensor.

LED

The Red LED will indicate whether the current is above (LED On) or below (LED Off) the fixed trip point. At very low monitored input currents the Red LED may not light to indicate the current is above the trip point.

FIGURE 2: OPENING A/SCS2 SERIES

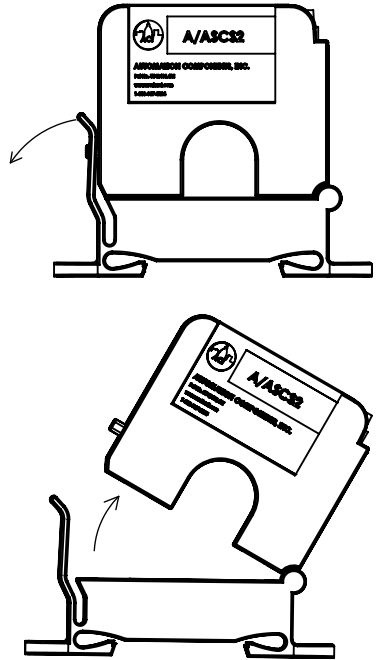

FIGURE 3: DIN RAIL INSTALLATION

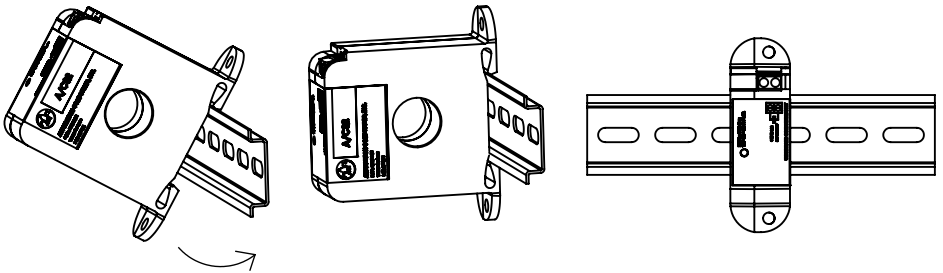
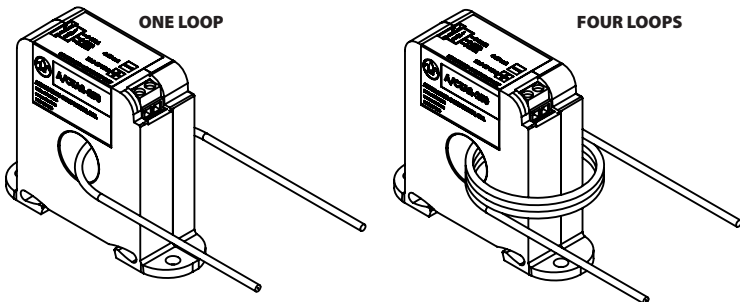

FIGURE 4: WIRES THROUGH SENSORS



APPLICATION NOTES

The conductor being monitored may be looped through the sensor multiple times. The loops increase the current measured by the current switch. Each time the conductor passes through the current switch window equals one loop (See **Figure 4** p. 2). To determine the proper number of loops required, take the rated Fixed Trip Point of the current switch and divide it by the Operating Current of the Monitored Device, add one (1), then round up to the nearest whole number. **Example:** When using the A/ACS2, a small fan operating at 0.1A should be wrapped through the sensor four times to give you a total operating current of 0.4 Amps flowing through the A/ACS2. Formula Example: $(0.25A/0.1A) = 2.5 + 1 = 3.5$, which rounded up equals 4 loops.

WIRING INSTRUCTIONS

ACI recommends the use of a two conductor 16 to 22 AWG shielded cable or twisted pair copper wire only, for all current switch applications. A maximum wire length of less than 30 meters (98.4 feet) should be used between the current switch and the Building Management System or controller.

Note: When using a shielded cable, be sure to connect only (1) end of the shield to ground at the controller. Connecting both ends of the shield to ground may cause a ground loop. When removing the shield from the sensor end, make sure to properly trim the shield to prevent any chance of shorting.

The current switch output terminals represent a solid-state switch for controlling both AC and DC loads and are not polarity sensitive. Tighten the screws at the terminal block connections to the recommended torque of 0.5 to 0.6 Nm (4.43 to 5.31 in-lbs.). The aperture (hole) size of the current switch is 0.75" (1.90 cm).

FIGURE 5: DIGITAL CIRCUIT

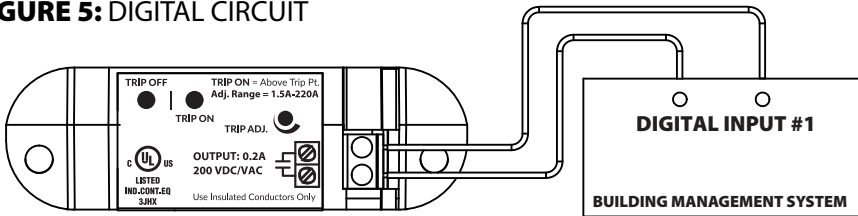
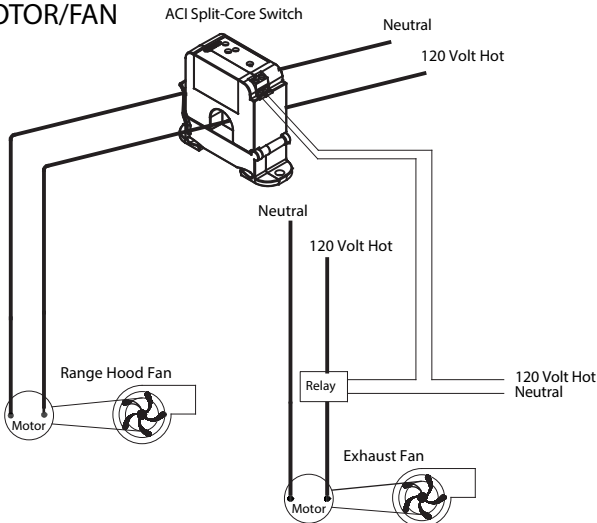

FIGURE 6: MOTOR/FAN CONTROL



APPLICATION EXAMPLES

See **Figure 5** (p.3) and **Figure 6** (p.3) for two different current switch applications. **Figure 5** (p.3) is showing the use of the Go/No Go Current Switch as a Digital Input to your BAS/PLC Controller. **Figure 6** (p.3) shows a Go/No/Go Current Switch in conjunction with a Contactor to control an exhaust fan.

Note: The ACI Go/No Go Current switches are only rated at 0.2A @ 200 VAC/VDC and must use an additional Contactor if controlling motor/fans.

CALIBRATION OF ADJUSTABLE TRIP POINT

The adjustable current switch has an operating range of 0-250 Amps, **Do not exceed!** The current switch has an adjustable trip point range of 0.50 - 220 Amps, 1.50 - 220 Amps, or 0.60 - 180 Amps depending on the model. See **Ordering Table** on p.5 to determine the adjustable trip point range per model number. The adjustable current switch comes with its fifteen-turn adjustment potentiometer set to the maximum trip point position. The adjustable current switch can monitor Underload, Normal Load, and Overload conditions, depending on how it's set. The procedure below is for the Normal load condition for part numbers A/ACS2, A/ASCS2 and A/ASCS2-L.

Normal Loads

With current flowing through the aperture of the adjustable current switches, first verify that the Blue LED is on. If the Blue LED is on, now slowly adjust the potentiometer clockwise until the Red LED just turns on and stop immediately. This will set the trip point at your normal operating load current.

If the RED LED is on after initial power up, this means that you will need to slowly adjust the potentiometer counter-clockwise until the Blue LED turns on and then slowly adjust the potentiometer clockwise until the Red LED just turns on and stop immediately. The adjustable current switch is now tripped. Now verify the output with an Ohmmeter to verify that the contacts of the switch are approximately 0.200 Ohms. The adjustable current switch Hysteresis (Dead Band) is typically 10% of the trip point.

Clockwise = Decrease Trip Point

Counter-clockwise = Increase Trip Point

TROUBLESHOOTING

PROBLEM	SOLUTION(S)
LED is on but the current switch didn't activate	Disconnect the wires from the current switch output. Measure the resistance across the contacts with an Ohmmeter. See Standard Ordering Table (p.5) for the actual resistance readings for an open or closed switch reading.
LED didn't turn on and the current switch didn't activate	Verify that the current flowing in the conductor being monitored is above the fixed trip point as listed in the operating specifications. If the sensor is monitoring less than the fixed trip point, see Figure 4 .
LED not on but the Current Switch is Activated	LED not indicating correctly, may have been damaged.
Current Switch is operating at a low-level current or failing to operate within the accuracy specifications	For A/ASCS2 Series, visually check the mating parts of the core to ensure there is no debris between the split contacts. Remove all debris or dust manually and close the current sensor, see Figure 2 . Retest the sensor in your application.

PRODUCT SPECIFICATIONS

SENSOR NON-SPECIFIC INFORMATION	
Monitored Current Type:	AC Current
Maximum AC Voltage:	600 VAC
Operating Frequency Range:	40 to 1 kHz
Core Style:	Solid-Core and Split-Core Versions available (See Ordering Grid)
Sensor Power:	Induced from the Monitored Conductor
Amperage Range:	See Ordering Grid
Isolation Voltage:	2200 VAC
Trip Point Style Trip Point:	Adjustable Trip Point See Ordering Grid
Contact Type:	Normally-Open "N/O" or Normally-Closed "N/C" (See ordering Grid)
"Status" Contact Rating:	0.2A @ 200 VAC/VDC
"Status" Contact "On" Resistance "Off" Resistance:	< 10 Ohms (tripped) > 1 Meg Ohms (Open)
Status LED Indication :	Red LED (Monitored current is above Trip Point)
Aperture Size:	0.75" (19.05 mm)
Din Rail Size:	35 mm (U.S. Patent No. 7,416,421)
Operating Temperature Range:	5 to 104°F (-15 to 40°C)
Operating Humidity Range:	0 to 95%, non-condensing
Wiring Connections:	2 Position Screw Terminal Block (Not Polarity Sensitive)
Wire Size:	16 to 22 AWG (1.31 mm ² to 0.33 mm ²) Copper Wires only
Terminal Block Torque Rating:	4.43 to 5.31 in.-lbs. (0.5 to 0.6 Nm)
Minimum Mounting Distance:	1" (2.6 cm) between current switch (Relays, Contactors, Transformers)

Note: The LED should not be used to determine if current is present. At low currents the LED may not be visible

STANDARD ORDERING

Model #	Item #	Trip Point Type	N/O	N/C	Solid-Core	Split-Core	Amp Range	Trip Point	Contact Rating
A/ACS2	142355	Adjustable	•		•		0 to 250A	0.5 to 220A	0.2A @ 200 VAC/VDC
A/ACSX2	142354	Adjustable		•	•		0 to 250A	0.5 to 220A	0.2A @ 200 VAC/VDC
A/ASCS2	142353	Adjustable	•			•	0 to 250A	1.5 to 220A	0.2A @ 200 VAC/VDC
A/ASCSX2	142370	Adjustable		•		•	0 to 250A	1.5 to 220A	0.2A @ 200 VAC/VDC
A/ASCS2-L	142352	Adjustable	•			•	0 to 250A	0.6 to 180A	0.2A @ 200 VAC/VDC

WARRANTY

The ACI Current Switch Series are covered by ACI's Five (5) Year Limited Warranty, which is located in the front of ACI'S SENSORS & TRANSMITTERS CATALOG or can be found on ACI's website: www.workaci.com.

W.E.E.E. DIRECTIVE

At the end of their useful life the packaging and product should be disposed of via a suitable recycling centre. Do not dispose of with household waste. Do not burn.

NOTES

NOTES



NOTES

NOTES



