

OPERATION

Step 1. Apply Power to the Instrument

When your device is first powered up it will display the ambient temperature (assume 75°F).

Step 2. Enter Setpoint 1 Menu

Press **⏏** one time from run mode to get to **SP1** Setpoint 1.

Step 3. Enter the Setpoint 1 Value Submenu

Press **⏏**. Display shows the previous selection of Setpoint 1.

Step 4. Change the Setpoint 1 Value

Press **▲** or **▼** until desired value is displayed.

Step 5. Store the Setpoint 1 Value

Set the Setpoint 1 to 10 degree higher than Process value (SP1 = 85) and press **⏏** to store, display flashes **SErD** message and advances to **SP2** Setpoint 2 Menu.

Step 6. Store the Setpoint 2 Value

Repeat steps 3 and 4. Set the Setpoint 2 to 5 degree higher than Process value (SP2 = 80) and press **⏏** to store, display flashes **SErD** message and advances to **ENFG** Configuration Menu.

Step 7. Enter the Reading Config Menu

Press **⏏** to enter **RdG** Reading Config Menu.

Step 8. Enter the submenu items of Rdg Config Menu

Press **⏏** to display **SNsr** Sensor submenu: Sensor selection for Autotune, Loop, or Ramp and Soak **F.TC** is for temperature and **o.PRH** is for Humidity

Step 9. Enter the submenu items of Rdg Config Menu

Press **⏏** to display Temp Unit submenu:

Step 10 Scroll thru selection for Temp Unit submenu

Press **⏏** to Scroll through the available selections of the Temperature Unit of your choice: **F** or **C**.

Step 11. Store the Temperature Unit

Press **⏏**, display momentarily shows **SErD** the Unit has been stored and the instrument will go automatically to the next menu item.

Step 12. Enter the Filter Constant Submenu

Display shows **FLtR** Filter Constant Submenu.

Step 13. Display the Filter Constant Value Submenu

Press **⏏** to display the flashing, previously selected Filter Constant.

Step 14. Scroll through available Filter Constants

Press **▲** to sequence thru Filter Constants **0001**, **0002**, **0004**, **0008**, **0016**, **0032**, **0064** and **0128**.

Step 15. Store the Filter Constant

Press **⏏** momentarily to store **0004** Filter Constant and the instrument will automatically go to the next menu item.

Step 16. Enter Alarm 1 Menu

The display will show **ALR1** the top menu for Alarm 1. In the following steps we are going to enable Alarm 1, Deviation, Unlatch, Normally Open, Active Above, Enable at power-on and +2°F High Alarm i.e. Process Value > Setpoint 1 Value +2°F will activate Alarm 1.

- If Analog Output Option is installed and enabled, the controller will skip Alarm 1 Menu item to Analog Output.
- Alarm must be DISABLED if Ramp is ENABLED.
- Alarm1 will only work for Humidity, not Temperature.

Alarm 1 is designed to monitor the humidity value around Setpoint 1 and Alarm 2 is designed to monitor the temperature value around Setpoint 2.

Step 17. Enter Alarm 1 Enable/Disable Submenu

Press **⏏** to display flashing **dsbl** / **ENBL**.

Step 18. Enable Alarm 1 Submenu

If flashing **ENBL** is displayed, press **⏏**, if **dsbl** is displayed, press **▲** until **ENBL** is displayed, then press **⏏** to store and go to the next menu item.

Step 19. Select the Deviation Control Type Submenu

Press **⏏**. If flashing **DEv** Deviation is displayed press **⏏**, otherwise press **▲** until flashing **DEv** is shown. Now press **⏏** to store and go to next menu item.

Step 20. Select the Latched Type Submenu

Press **⏏**. If flashing **UNL** Unlatched is displayed press **⏏**, otherwise press **▲** until **UNL** is displayed. Press **⏏** to store and advance to next menu item.

Step 21. Select the Normally Open Type of Contact Closure Submenu

Press **⏏**. If flashing **N.o.** Normally Open is displayed, press **⏏**, otherwise press **▲** until **N.o.** is displayed. Press **⏏** to store and advance to next menu item.

Step 22. Select the Above Type of Active Submenu

Press **⏏**. If flashing **Abv** Above is displayed, press **⏏**, otherwise press **▲** until **Abv** is displayed. Press **⏏** to store and advance to next menu item.

Step 23. Enable Alarm 1 at Power On (R.P.O.N)

Press **⏏**. If flashing **ENBL** is displayed, press **⏏**, otherwise press **▲** until **ENBL** is displayed. Press **⏏** to store and advance to next menu item.

Step 24. Enter Alarm 1 High Submenu

Press **⏏** twice to skip **ALR.L** Alarm 1 Low value. **ALR.L** is for below & **ALR.H** for above.

Step 25. Set the Alarm 1 High value (ALR.H)

Press **⏏**. Press **▲** or **▼** until value to set the display to **002.0**. Press **⏏** to save.

Step 26. Enter the Alarm 2 Menu

The display will show **ALR2** the top menu for Alarm 2. Repeat steps from 17 to 25 to set for Alarm 2 the same conditions as for Alarm 1.

Step 29. Configuration of Display Color Selection

Press **⏏** until the **COLR** Display Color Selection Menu appears on the Display. Configure **COLR** as **NCLR** / **GRN** (green), **ICLR** / **RED** (red), **ELCR** / **AMBR** (amber). Please refer to the operator's manual if needed.

For color change on Setpoints refer to Owners Manual Section 2.

SPECIFICATION

SENSOR SPECIFICATIONS

Relative Humidity Accuracy/Range:

±2% for 10 to 90%
±3% for 5 to 10% and 90 to 95%
±4% for 0 to 5% and 95 to 100%

Non-linearity: ±3%

Hysteresis: ±1% RH

Response Time:

8 sec, tau 63%

Repeatability: ±0.1%

Resolution: 0.1%, 12bit

Temperature Accuracy/Range*:

±0.5°C for 5 to 45°C (±1°F for 41 to 113°F);
up to ±1.5°C for -40 to 5°C and 45 to 124°C
(up to ±2.7°F for -40 to 41°F and 113 to 257°F)

*NOTE: extended temp range is for Probe only, the Controller's operating temp is 0-50°C

Response Time:

5 to 30 sec, tau 63%

Repeatability: ±0.1°C

Resolution: 0.1°C, 14 bit

METER SPECIFICATIONS

Display:

- 4-digit, 9-segment LED,
- 10.2 mm (0.40"): DPiTH-i8DV Dual Vertical
- 10.2 mm (0.40") and 21 mm (0.83") DPiTH-i8DH Dual Horizontal

Red, green, and amber programmable colors for setpoint and temperature units.

Output 1*:

Relay 250 Vac @ 3 A Resistive Load, SSR, Pulse

Output 2*:

Relay 250 Vac @ 3 A Resistive Load, SSR, Pulse

* Only with -AL Limit Alarm option

Options: Communication

RS-232 / RS-485 or 10BaseT

or Excitation: 24 Vdc @ 25 mA

Exc. not available for Low Power Option

Line Voltage/Power:

90 - 240 Vac ±10%, 50 - 400 Hz*,

or 110 - 375 Vdc, 5 W

* No CE compliance above 60 Hz

Low Voltage Power Option:

20 - 36 Vdc or 24 Vac** ±10%, 4 W

** Units can be powered safely with 24 Vac

but No Certification for CE/UL are claimed.

Dimensions:

Dual Horizontal: 48H x 96W x 127D mm

(1.89 x 3.78 x 5")

Dual Vertical: 48W x 96H x 127D mm

(1.89 x 3.78 x 5")

Weight:

295 g (0.65 lb)

Approvals:

CE per EN61010-1:2001

WARNING: These products are not designed for use in, and should not be used for, patient-connected applications.

This device is marked with the international caution symbol. It is important to read the Setup Guide before installing or commissioning this device, as the guide contains important information relating to safety and EMC.

It is the policy of OMEGA to comply with all worldwide safety and EMC/EMI regulations that apply. OMEGA is constantly pursuing certification of its products to the European New Approach Directives. OMEGA will add the CE mark to every appropriate device upon certification.

The information contained in this document is believed to be correct, but OMEGA Engineering, Inc. accepts no liability for any errors it contains, and reserves the right to alter specifications without notice.

TRADEMARK NOTICE:

Ω, **omega.com**, **Ω OMEGA**, and **i** are Trademarks of OMEGA ENGINEERING, INC.

WARRANTY/DISCLAIMER	
<p>OMEGA ENGINEERING, INC. warrants this unit to be free of defects in materials and workmanship for a period of one (1) year from the date of purchase. In addition to OMEGA's standard warranty period, OMEGA Engineering will extend the warranty period for four (4) additional years if the warranty card enclosed with each instrument is returned to OMEGA.</p> <p>If the unit malfunctions, it must be returned to the factory for evaluation. OMEGA's Customer Service Department will issue an Authorized Return (AR) number immediately upon phone or written request. Upon examination by OMEGA, if the unit is found to be defective, it will be repaired or replaced at no charge. OMEGA's WARRANTY does not apply to defects resulting from any action of the purchaser, including but not limited to mishandling, improper interfacing, operation outside of design limits, improper repair, or unauthorized modification. This WARRANTY is VOID if the unit shows evidence of having been tampered with or shows evidence of having been damaged as a result of excessive corrosion, or current, heat, moisture or vibration, improper specification, misapplication, misuse or other operating conditions outside OMEGA's control. Components which wear are not warranted, including but not limited to contact points, fuses, and triacs.</p> <p>OMEGA is pleased to offer suggestions on the use of its various products. However, OMEGA neither assumes responsibility for any omissions or errors nor assumes liability for any damages that result from the use of its products in accordance with information provided by OMEGA, either verbal or written. OMEGA warrants only that the parts manufactured by it will be as specified and free of defects. OMEGA MAKES NO OTHER WARRANTIES OR REPRESENTATIONS OF ANY KIND WHATSOEVER, EXPRESS OR IMPLIED, EXCEPT THAT OF TITLE, AND ALL IMPLIED WARRANTIES INCLUDING ANY WARRANTY OF MERCHANTABILITY AND FITNESS FOR A PARTICULAR PURPOSE ARE HEREBY DISCLAIMED. LIMITATION OF LIABILITY: The remedies of purchaser set forth herein are exclusive, and the total liability of OMEGA with respect to this order, whether based on contract, warranty, negligence, indemnification, strict liability or otherwise, shall not exceed the purchase price of the component upon which liability is based. In no event shall OMEGA be liable for consequential, incidental or special damages.</p> <p>CONDITIONS: Equipment sold by OMEGA is not intended to be used, nor shall it be used: (1) as a "Basic Component" under 10 CFR 21 (NRC), used in or with any nuclear installation or activity; or (2) in medical applications or used on humans. Should any Product(s) be used in or with any nuclear installation or activity, medical application, used on humans, or misused in any way, OMEGA assumes no responsibility as set forth in our basic WARRANTY/DISCLAIMER language, and, additionally, purchaser will indemnify OMEGA and hold OMEGA harmless from any liability or damage whatsoever arising out of the use of the Product(s) in such a manner.</p>	
RETURN REQUESTS/INQUIRIES	
<p>Direct all warranty and repair requests/inquiries to the OMEGA Customer Service Department. BEFORE RETURNING ANY PRODUCT(S) TO OMEGA, PURCHASER MUST OBTAIN AN AUTHORIZED RETURN (AR) NUMBER FROM OMEGA'S CUSTOMER SERVICE DEPARTMENT (IN ORDER TO AVOID PROCESSING DELAYS). The assigned AR number should then be marked on the outside of the return package and on any correspondence.</p> <p>The purchaser is responsible for shipping charges, freight, insurance and proper packaging to prevent breakage in transit.</p>	
<p>FOR WARRANTY RETURNS, please have the following information available BEFORE contacting OMEGA:</p> <ol style="list-style-type: none"> 1. Purchase Order number under which the product was PURCHASED, 2. Model and serial number of the product under warranty, and 3. Repair instructions and/or specific problems relative to the product. 	<p>FOR NON-WARRANTY REPAIRS, consult OMEGA for current repair charges. Have the following information available BEFORE contacting OMEGA:</p> <ol style="list-style-type: none"> 1. Purchase Order number to cover the COST of the repair, 2. Model and serial number of product, and 3. Repair instructions and/or specific problems relative to the product.
<p>OMEGA's policy is to make running changes, not model changes, whenever an improvement is possible. This affords our customers the latest in technology and engineering.</p> <p>OMEGA is a registered trademark of OMEGA ENGINEERING, INC.</p> <p>© Copyright 2011 OMEGA ENGINEERING, INC. All rights reserved. This document may not be copied, photocopied, reproduced, translated, or reduced to any electronic medium or machine-readable form, in whole or in part, without the prior written consent of OMEGA ENGINEERING, INC.</p> <p>PATENT AND TRADEMARK NOTICE: This product is covered by one or more of the following patents: U.S. Pat. No. Des. 336,895; 5,274,577; 6,243,021 / CANADA 2052599; 2052600 / ITALY 1249456; 1250938 / GERMANY DE 41 34398 C2 / SPAIN 2039150; 2048066 / UK Patent No. GB2 249 837; GB2 248 954 / FRANCE BREVET NO. 91 12756. The "Meter Bezel Design" is a trademark of Newport Electronics, Inc. USED UNDER LICENSE. Other U.S. and International Patents pending or applied for.</p>	

MQS4003/0611



DPiTH-i8DH, DPiTH-i8DV
Humidity + Temperature Monitor
CNiTH-i8DH-AL, CNiTH-i8DV-AL
Humidity + Temperature Limit Alarm

omega.com
Ω OMEGA

OMEGAnet® On-Line Service omega.com	Internet e-mail info@omega.com
--	-----------------------------------

Servicing North America:

USA: ISO 9001 Certified	One Omega Drive, P.O. Box 4047 Stamford CT 06907-0047 TEL: (203) 359-1660 e-mail: info@omega.com	FAX: (203) 359-7700
Canada:	976 Bergar Laval (Quebec) H7L 5A1 TEL: (514) 856-6928 e-mail: info@omega.ca	FAX: (514) 856-6886

For immediate technical or application assistance:

USA and Canada:	Sales Service: 1-800-826-6342 / 1-800-TC-OMEGA® Customer Service: 1-800-622-2378 / 1-800-622-BEST® Engineering Service: 1-800-872-9436 / 1-800-USA-WHEN®
------------------------	--

Mexico and Latin American:	TEL: (001) 203-359-7803 e-mail: espanol@omega.com	FAX: (001) 203-359-7807
-----------------------------------	--	-------------------------

Servicing Europe:

Benelux:	Managed by the United Kingdom Office TEL: +31 20 347 2121 Toll Free in Benelux: 0800 099 3344 e-mail: sales@omegaeng.nl	FAX: +31 20 643 4643
Czech Republic:	Frystatska 184, 733 01 Karviná TEL: +420 59 6311899 e-mail: info@omegashop.cz	FAX: +420 59 6311114
France:	Managed by the United Kingdom Office TEL: +33 1 61 37 29 00 Toll Free in France: 0800 466 342 e-mail: sales@omega.fr	FAX: +33 1 30 57 54 27
Germany/Austria:	Daimlerstrasse 26, D-75392 Deckenpfronn, Germany TEL: +49 7056 9398-0 Toll Free in Germany: 0800 639 7678 e-mail: info@omega.de	FAX: +49 7056 9398-29
United Kingdom: ISO 9001 Certified	One Omega Drive River Bend Technology Centre Northbank, Irlam Manchester M44 5BD United Kingdom TEL: +44 161 777 6611 Toll Free in England: 0800 488 488 e-mail: sales@omega.co.uk	FAX: +44 161 777 6622



This Quick Start Reference provides information on setting up your instrument for basic operation. The latest complete Communication and Operational Manual as well as free Software and ActiveX Controls are available at www.omega.com/specs/iseries or on the CD-ROM enclosed with your shipment.

SAFETY CONSIDERATION



This device is marked with the international Caution symbol.

The instrument is a panel mount device protected in accordance with EN61010-1:2001. Remember that the unit has no power-on switch. Building installation should include a switch or circuit-breaker that must be compliant to IEC 947-1 and 947-3.

SAFETY:

- Do not exceed voltage rating on the label located on the top of the instrument housing.
- Always disconnect power before changing signal and power connections.
- Do not use this instrument on a work bench without its case for safety reasons.
- Do not operate this instrument in flammable or explosive atmospheres.
- Do not expose this instrument to rain or moisture.

EMC:

- Whenever EMC is an issue, always use shielded cables.
- Never run signal and power wires in the same conduit.
- Use signal wire connections with twisted-pair cables.
- Install Ferrite Bead(s) on signal wire close to the instrument if EMC problems persist.

MOUNTING

Panel Mounting Instruction:

- Using the dimensions from the panel cutout shown in exploded views, cut an opening in the panel. 45mm +.61/-0.00 x 92mm +.81/-0.00 with R 1.5, 4 places (1.772" +.024/-0.000 x 3.622" +.032/-0.000 with R 0.06", 4 places) Panel thickness: 6.4mm (0.25") max / 0.8mm (0.03") min.
- Remove sleeve from the rear of the case by removing thumbnuts.
- Insert the unit into the opening from the front of the panel, so the gasket seals between the bezel and the front of the panel.
- Slip the sleeve over the rear of the case.
- Tighten the thumbnuts to hold the unit firmly in the panel.

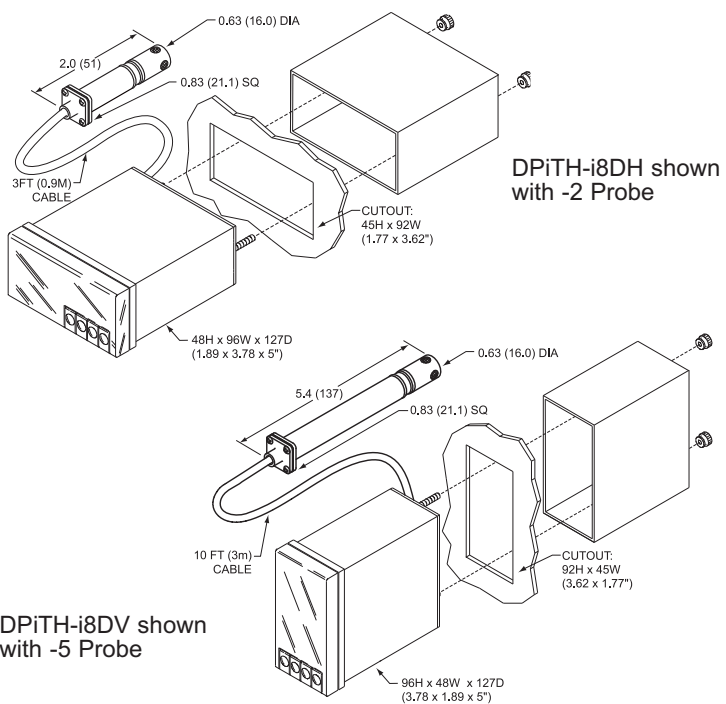

DPiTH-i8DV shown with -5 Probe

Disassembly Instruction:

If necessary, the unit may be removed from the panel and opened.



Warning: Disconnect all ac power from the unit before proceeding.

- Remove all wiring connections from the rear of the instrument, by unplugging the power and input connectors.
- The meter is front removable from the case
- Pull the board assembly out of the case.

WIRING

Wire the instrument according to the figure shown below.



Warning: Do not connect ac power to your device until you have completed all input and output connections. This device must only be installed by a specially trained electrician with corresponding qualifications. Failure to follow all instructions and warnings may result in injury!

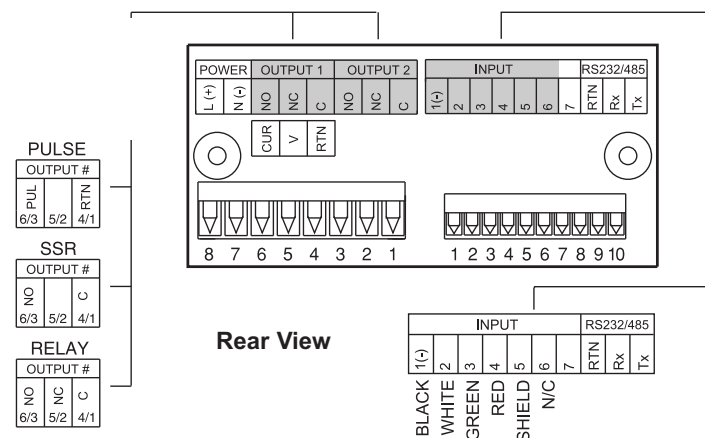

Refer to Operator's Manual for important Input Probe Shield wiring notes

Connect the main power connections as shown in the figure below.

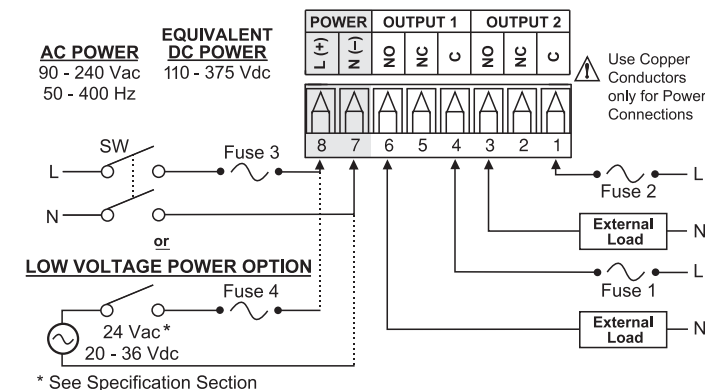

FUSE	Connector	Output Type	For 115Vac	For 230Vac	DC
FUSE 1	Output 1	Relay	3 A(T)	3 A(T)	-
FUSE 2	Output 2	Relay	3 A(T)	3 A(T)	-
FUSE 3	Power	N/A	100 mA(T)	100 mA(T)	100 mA(T)
FUSE 4	Power	N/A	N/A	N/A	400 mA(T)

Output 1 and 2 are for -AL Limit Alarm Option only.

DESCRIPTION OF FRONT PANEL

The upper display may be RH, Temperature or Dewpoint readings depending on your Reading Configuration selections. Factory defaults are shown. The Dual Display allows the user to observe the Relative Humidity or Dewpoint (upper display) and Temperature Value (lower display), at the same time.

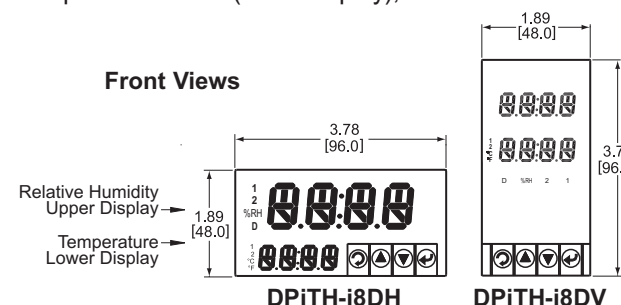

1	Output 1/Setpoint 1/ Alarm 1 indicator
2	Output 2/Setpoint 2/ Alarm 2 indicator
°C	°C unit indicator for Temperature or Dewpoint
°F	°F unit indicator for Temperature or Dewpoint
%RH	Display shows the Percent Relative Humidity
D	Display shows the Dewpoint
↻	Changes display to Configuration Mode and advances through menu items*
⏪	Used in Program Mode:
⏩	Used in Program Mode:
⏴	Accesses submenus in Configuration Mode and stores selected values*

CONFIGURATION

The instrument has two different modes of operation. **Run Mode:** used to display Temperature and Relative Humidity. **Menu Configuration Mode:** used to navigate through the menu options and configure the controller.

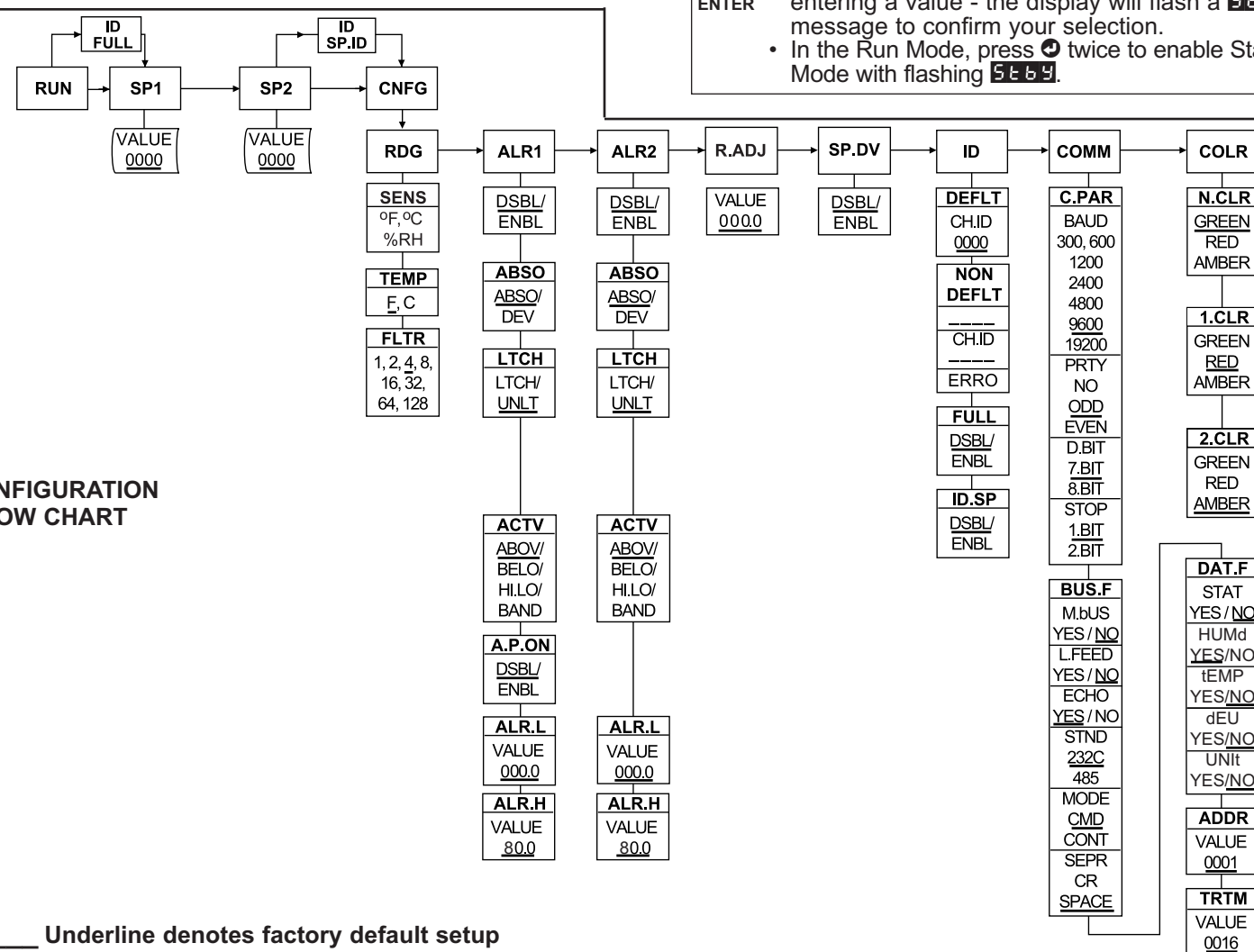

Underline denotes factory default setup

Button Function in Configuration Mode

- MENU**
 - To enter the Menu, the user must first press **↻** button.
 - Use this button to advance/navigate to the next menu item. The user can navigate through all the top level menus by pressing **↻**.
 - While a parameter is being modified, press **↻** to escape without saving the parameter.
- (UP)**
 - Press the up **⏩** button to scroll through "flashing" selections. When a numerical value is displayed press this key to increase value of a parameter that is currently being modified.
 - Pressing the **⏩** button for approximately 3 seconds will speed up the rate at which the set point value increments.
 - In the Run Mode, pressing the **⏩** button changes display from RH readings to Temperature readings.
- (DOWN)**
 - Press the down **⏪** button to go back to a previous Top Level Menu item.
 - Press this button twice to reset the controller to the Run Mode.
 - When a numerical value is flashing (except set point value) press **⏪** to scroll digits from left to right allowing the user to select the desired digit to modify.
 - When a setpoint value is displayed press **⏪** to decrease value of a setpoint that is currently being modified. Pressing the **⏪** button for approximately 3 seconds will speed up the rate at which the setpoint value is decremented.
 - In the Run Mode, pressing the **⏪** button changes from RH readings to Dewpoint readings.
- ENTER**
 - Press the enter **↵** button to access the submenus from a Top Level Menu item.
 - Press **↵** to store a submenu selection or after entering a value - the display will flash a **ST.RD** message to confirm your selection.
 - In the Run Mode, press **↵** twice to enable Standby Mode with flashing **STBY**.