

HHC280 Differential Manometer

M5515/0418

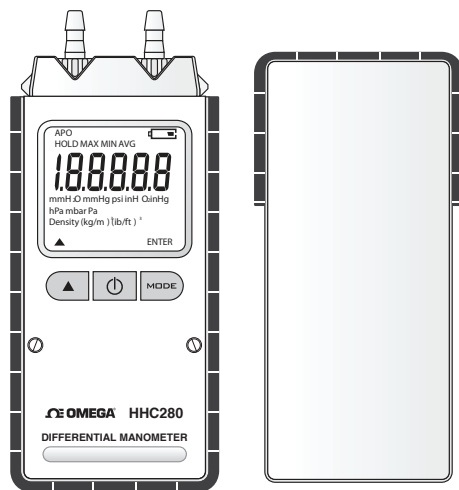

Shop online at omega.com e-mail: info@omega.com
For latest product manuals: omegamanual.info



SPECIFICATIONS

Unit	Range	Resolution
mmH ₂ O	0 to 1019.7	0.1
mmHg	0 to 75.00	0.01
psi	0 to 1.450	0.001
inH ₂ O	0 to 40.14	0.01
inHg	0 to 2.953	0.001
hPa	0 to 100.00	0.01
mbar	0 to 100.00	0.01
Pa	0 to 10000	1
fpm	*	1
m/s	*	0.1

Accuracy: Nominal temperature 22°C, ±1dgt)
±0.03 hPa(0 to 0.30 hPa),
±0.05 hPa(0.31 to 1.00 hPa),
±(0.1 hPa+1.5% of reading) (rest of range)
±0.3 mmH₂O(0 to 3.0 mmH₂O),
±0.5 mmH₂O(3.1 to 10.2 mmH₂O),
±(1.02 mmH₂O + 1.5% of reading) (rest of range)

Measurement rate: 2 times/second.

Auto power off: 10 minutes.

Low battery indication: The “” is displayed when the battery voltage drops below the operating level.

Operating Environment: 0°C to 50°C (32°F to 122°F) at < 70% R.H.

Storage Temperature: -20°C to 60°C (-4°F to 140°F), 0 to 80% R.H. with battery removed from meter.

Battery: 1.5Vx2pcs AAA size.

Battery Life: 85 hours typical.

Dimensions: 24.7mm(T) x 50.9mm(W) x 132.9mm(H).

Weight: Approx. 113g. (Including batteries)

OPERATIONS

There are 3 operation modes, namely Measurement Mode, Set Mode and Hold Mode.

1. Turning on and off the meter:

When power is off, a short push on “” key turns on the meter and enter Measurement Mode.

When power is on press and hold “” key for 2 seconds turns the power off.

Right after power on, all the indicators on the LCD display lights up for one second.

2. Measurement Mode:

Before start measuring, disconnect the meter from pressure sources, press “” key to zero the meter. (When there is a measurement > 10hpa, Zeroing function is disabled).

Connect the meter to the pressure sources, the meter start measuring and refresh every 0.5 seconds.

Backlight:

In measurement mode, a short push on “” key turns on the backlight for dark environment, it goes off automatically after 15 seconds if without further operation.

3. Set Mode:

In set mode, user can select Unit, Density of Medium and turn on/off APO function.(APO = Auto Power Off, when APO is ON, the meter power off automatically if no operation in 10 minutes.)

When power is off, press and hold “” key for 2 seconds to enter Set Mode.

3.1 Unit setting: Press “” key to change unit (press and hold “” key, to scroll units), press “MODE” to selection the unit and enter next setting. If unit of air speed (fpm or m/s) is selected, then next setting is density setting otherwise APO setting.

3.2 Density of the medium setting: Press “” key to change value (press and hold “” key to scroll values), press “MODE” key to select and enter APO On/Off setting (Max. Density: 0.624lb/ft³ or 9.999kg/m³)

3.3 APO ON/OFF: short push on “” key switches

between ON and OFF. Push “MODE” key to select, exit Set Mode and Enter Measurement Mode.

(Please refer to the section of Measurement Mode.)

※**Note:** To turn off power in Set Mode abandon the current setting and previous settings remain unchanged. If “” indicator appeared, the setting value can works till power off but did not save to meter.

4. Hold Mode:

In Measurement Mode, short push “Mode” key to enter Hold Mode with indicator “HOLD” shows at upper left corner of LCD.

Right after entering this mode, shown in the LCD is the last measurement and the reading will not be updated with new measurement.

Push “Mode” key each time the display changes in following sequence:

4.1 Last Measurement: with indicator “HOLD”.

4.2 Maximum value recorded: with indicator “HOLD” + “MAX”.

4.3 Minimum value recorded: with indicator “HOLD” + “MIN”.

4.4 Maximum-Minimum value recorded: with indicator “HOLD” + “MAX-MIN”.

4.5 Average of values recorded: with indicator “HOLD” + “AVG”. (only for wind speed)

4.6 Exit the Hold Mode and return to Measurement Mode.

To clear the recorded values:

In Hold Mode and during viewing MAX, MIN, MAX-MIN or AVG, press and hold “Mode” key for 2 seconds, to clear the recorded data and return to measurement mode.

Installing and Replacing Battery

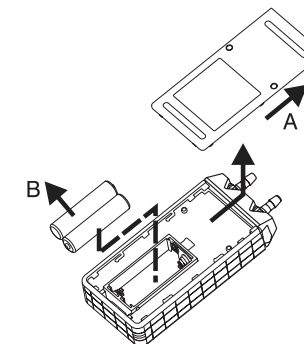

A. Battery Cover
B. Battery

- Power is supplied by 2pcs 1.5V (AAA SIZE).
- The “” appears in the display when battery replacement is needed.
- Push the Battery Cover and lift it in the direction as shown in the figure.
- Remove the batteries from battery compartment.
- Replace with 2 new AAA batteries with polarity as indicated on the bottom of Battery Compartment.
- Replace the Battery Cover.

※**Note:** When not use for long time remove battery and don't keep in place with high Temp, or high humidity.

Cleaning

Periodically wipe the case with a damp cloth and detergent, do not use abrasives or solvents.

INTRODUCTION

This instrument is design to measure the difference between the pressures applied on the two ports of the meter. With a Pitot tube (separate purchasing) the meter also measures air speed.

Besides displaying result of current measurement, and hold function the meter also store max / min / max-min / avg values.

SAFETY INFORMATION

Only operate the measuring instrument properly, for its intended purpose and within the units specified in the technical data. Do not use force.

Never store the product together with solvents, acids or other aggressive substances.

Only carry out the maintenance and repair work that is described in the documentation. Follow the prescribed steps when doing so.

WARRANTY/DISCLAIMER

OMEGA ENGINEERING, INC. warrants this unit to be free of defects in materials and workmanship for a period of **13 months** from date of purchase. OMEGA's WARRANTY adds an additional one (1) month grace period to the normal **one (1) year product warranty** to cover handling and shipping time. This ensures that OMEGA's customers receive maximum coverage on each product.

If the unit malfunctions, it must be returned to the factory for evaluation. OMEGA's Customer Service Department will issue an Authorized Return (AR) number immediately upon phone or written request. Upon examination by OMEGA, if the unit is found to be defective, it will be repaired or replaced at no charge. OMEGA's WARRANTY does not apply to defects resulting from any action of the purchaser, including but not limited to mishandling, improper interfacing, operation outside of design limits, improper repair, or unauthorized modification. This WARRANTY is VOID if the unit shows evidence of having been tampered with or shows evidence of having been damaged as a result of excessive corrosion; or current, heat, moisture or vibration; improper specification; misapplication; misuse or other operating conditions outside of OMEGA's control. Components in which wear is not warranted, include but are not limited to contact points, fuses, and triacs.

OMEGA is pleased to offer suggestions on the use of its various products. However, OMEGA neither assumes responsibility for any omissions or errors nor assumes liability for any damages that result from the use of its products in accordance with information provided by OMEGA, either verbal or written. OMEGA warrants only that the parts manufactured by the company will be as specified and free of defects. OMEGA MAKES NO OTHER WARRANTIES OR REPRESENTATIONS OF ANY KIND WHATSOEVER, EXPRESSED OR IMPLIED, EXCEPT THAT OF TITLE, AND ALL IMPLIED WARRANTIES INCLUDING ANY WARRANTY OF MERCHANTABILITY AND FITNESS FOR A PARTICULAR PURPOSE ARE HEREBY DISCLAIMED. LIMITATION OF LIABILITY: The remedies of purchaser set forth herein are exclusive, and the total liability of OMEGA with respect to this order, whether based on contract, warranty, negligence, indemnification, strict liability or otherwise, shall not exceed the purchase price of the component upon which liability is based. In no event shall OMEGA be liable for consequential, incidental or special damages.

CONDITIONS: Equipment sold by OMEGA is not intended to be used, nor shall it be used: (1) as a "Basic Component" under 10 CFR 21 (NRC), used in or with any nuclear installation or activity; or (2) in medical applications or used on humans. Should any Product(s) be used in or with any nuclear installation or activity, medical application, used on humans, or misused in any way, OMEGA assumes no responsibility as set forth in our basic WARRANTY/DISCLAIMER language, and, additionally, purchaser will indemnify OMEGA and hold OMEGA harmless from any liability or damage whatsoever arising out of the use of the Product(s) in such a manner.

RETURN REQUESTS/INQUIRIES

Direct all warranty and repair requests/inquiries to the OMEGA Customer Service Department. BEFORE RETURNING ANY PRODUCT(S) TO OMEGA, PURCHASER MUST OBTAIN AN AUTHORIZED RETURN (AR) NUMBER FROM OMEGA'S CUSTOMER SERVICE DEPARTMENT (IN ORDER TO AVOID PROCESSING DELAYS). The assigned AR number should then be marked on the outside of the return package and on any correspondence.

The purchaser is responsible for shipping charges, freight, insurance and proper packaging to prevent breakage in transit.

FOR **WARRANTY** RETURNS, please have the following information available BEFORE contacting OMEGA:

1. Purchase Order number under which the product was PURCHASED,
2. Model and serial number of the product under warranty, and
3. Repair instructions and/or specific problems relative to the product.

FOR **NON-WARRANTY** REPAIRS, consult OMEGA for current repair charges. Have the following information available BEFORE contacting OMEGA:

1. Purchase Order number to cover the COST of the repair,
2. Model and serial number of the product, and
3. Repair instructions and/or specific problems relative to the product.

OMEGA's policy is to make running changes, not model changes, whenever an improvement is possible. This affords our customers the latest in technology and engineering.

OMEGA is a trademark of OMEGA ENGINEERING, INC.

© Copyright 2018 OMEGA ENGINEERING, INC. All rights reserved. This document may not be copied, photocopied, reproduced, translated, or reduced to any electronic medium or machine-readable form, in whole or in part, without the prior written consent of OMEGA ENGINEERING, INC.



omega.com info@omega.com

Servicing North America:

U.S.A.
Headquarters:

Omega Engineering, Inc.
Toll-Free: 1-800-826-6342 (USA & Canada only)
Customer Service: 1-800-622-2378 (USA & Canada only)
Engineering Service: 1-800-872-9436 (USA & Canada only)
Tel: (203) 359-1660 Fax: (203) 359-7700
e-mail: info@omega.com

For Other Locations Visit omega.com/worldwide

Where Do I Find Everything I Need for
Process Measurement and Control?
OMEGA...Of Course!
Shop online at omega.com

TEMPERATURE

- Thermocouple, RTD & Thermistor Probes, Connectors, Panels & Assemblies
- Wire: Thermocouple, RTD & Thermistor
- Calibrators & Ice Point References
- Recorders, Controllers & Process Monitors
- Infrared Pyrometers

PRESSURE, STRAIN AND FORCE

- Transducers & Strain Gages
- Load Cells & Pressure Gages
- Displacement Transducers
- Instrumentation & Accessories

FLOW/LEVEL

- Rotameters, Gas Mass Flowmeters & Flow Computers
- Air Velocity Indicators
- Turbine/Paddlewheel Systems
- Totalizers & Batch Controllers

pH/CONDUCTIVITY

- pH Electrodes, Testers & Accessories
- Benchtop/Laboratory Meters
- Controllers, Calibrators, Simulators & Pumps
- Industrial pH & Conductivity Equipment

DATA ACQUISITION

- Communications-Based Acquisition Systems
- Data Logging Systems
- Wireless Sensors, Transmitters, & Receivers
- Signal Conditioners
- Data Acquisition Software

HEATERS

- Heating Cable
- Cartridge & Strip Heaters
- Immersion & Band Heaters
- Flexible Heaters
- Laboratory Heaters

ENVIRONMENTAL MONITORING AND CONTROL

- Metering & Control Instrumentation
- Refractometers
- Pumps & Tubing
- Air, Soil & Water Monitors
- Industrial Water & Wastewater Treatment
- pH, Conductivity & Dissolved Oxygen Instruments