

1 YEAR
WARRANTY

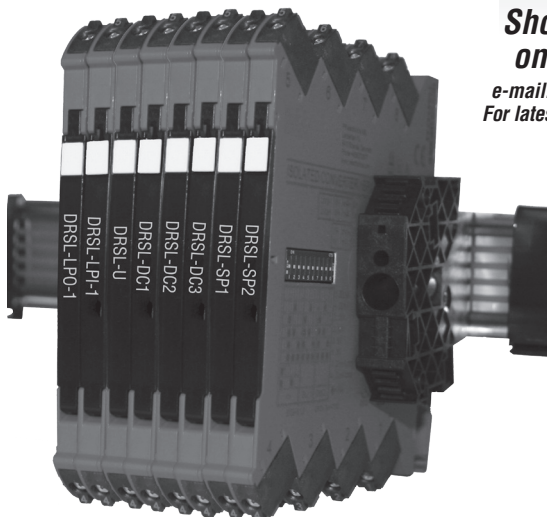

OMEGA® User's Guide



*Shop online at
omega.com®*

*e-mail: info@omega.com
For latest product manuals:
omegamanual.info*

DRSL-DC4
Bipolar Isolated DIN Rail
Signal Conditioner



omega.com info@omega.com

Servicing North America:

U.S.A.: Omega Engineering, Inc., One Omega Drive, P.O. Box 4047
Stamford, CT 06907-0047 USA
Toll-Free: 1-800-826-6342 (USA & Canada only)
Customer Service: 1-800-622-2378 (USA & Canada only)
Engineering Service: 1-800-872-9436 (USA & Canada only)
Tel: (203) 359-1660 Fax: (203) 359-7700
e-mail: info@omega.com

For Other Locations Visit omega.com/worldwide

The information contained in this document is believed to be correct, but OMEGA accepts no liability for any errors it contains, and reserves the right to alter specifications without notice.

WARNING: These products are not designed for use in, and should not be used for, human applications.

DRSL SERIES BIPOLAR ISOLATED SIGNAL CONDITIONER

DRSL-DC4

CONTENTS

Warning.....	2
Safety instructions.....	3
Mounting and demounting of system DRSL Series.....	5
Installation on DIN rail.....	6
Marking.....	6
Side label.....	7
Applications.....	8
Technical characteristics.....	8
Mounting / installation.....	8
Specifications.....	9
DIP-switch configuration.....	11
Front LED indication (green).....	11
Connections.....	12



GENERAL



**HAZARD-
OUS
VOLTAGE**



CAUTION

WARNING

To avoid the risk of electric shock and fire, the safety instructions of this guide must be observed and the guidelines followed. The specifications must not be exceeded, and the device must only be applied as described in the following. Prior to the commissioning of the device, this installation guide must be examined carefully. Only qualified personnel (technicians) should install this device. If the equipment is used in a manner not specified by the manufacturer, the protection provided by the equipment may be impaired. Until the device is fixed, do not connect hazardous voltages to the device.

Repair of the device must be done by OMEGA Engineering only.

In applications where hazardous voltage is connected to in-/outputs of the device, sufficient spacing or isolation from wires, terminals and enclosure - to surroundings (incl. neighbouring devices), must be ensured to maintain protection against electric shock.

Potential electrostatic charging hazard. To avoid the risk of explosion due to electrostatic charging of the enclosure, do not handle the units unless the area is known to be safe, or appropriate safety measures are taken to avoid electrostatic discharge.

SYMBOL IDENTIFICATION



Triangle with an exclamation mark: Read the manual before installation and commissioning of the device in order to avoid incidents that could lead to personal injury or mechanical damage.



The CE mark proves the compliance of the device with the essential requirements of the directives.

SAFETY INSTRUCTIONS

RECEIPT AND UNPACKING

Unpack the device without damaging it. The packing should always follow the device until this has been permanently mounted. Check at the receipt of the device whether the type corresponds to the one ordered.

ENVIRONMENT

Avoid direct sunlight, dust, high temperatures, mechanical vibrations and shock, as well as rain and heavy moisture. If necessary, heating in excess of the stated limits for ambient temperatures should be avoided by way of ventilation.

All devices can be used for Measurement / Overvoltage Category II and Pollution Degree 2.

The device is designed to be safe at least under an altitude up to 2 000 m.

MOUNTING

Mounting and connection of the device should comply with national legislation for mounting of electric materials, i.e. wire cross section, protective fuse, and location. Descriptions of input / output and supply connections are shown in this installation guide and on the side label.

The device is provided with field wiring terminals and shall be supplied from a Power Supply having double / reinforced insulation. A power switch should be easily accessible and close to the device. The power switch shall be marked as the disconnecting unit for the device.

DRSL Series must be mounted on a DIN rail according to EN 60715.

UL installation

Use 60/75°C copper conductors only.

Wire size AWG 26-12

UL file number..... E70366

The device is an Open Type Listed Process Control Equipment. To prevent injury resulting from accessibility to live parts the equipment must be installed in an enclosure.

The power Supply unit must comply with NEC Class 2, as described by the National Electrical Code® (ANSI / NFPA 70).

Cleaning

When disconnected, the device may be cleaned with a cloth moistened with distilled water.

MOUNTING AND DEMOUNTING OF DRSL SERIES

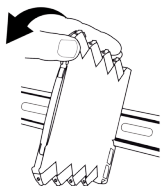

Picture 1:

Mounting on DIN rail.

Click the device onto the rail.

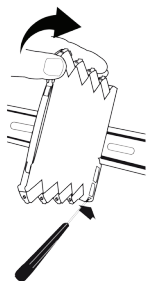

Picture 2:

Demounting from DIN rail

First, remember to demount the connectors with hazardous voltages.

Detach the device from the DIN rail by lifting the bottom lock.

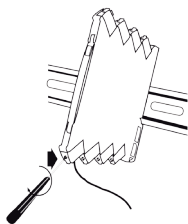

Picture 3:

Wire size AWG 26-12 / $0.13 \times 2.5 \text{ mm}^2$ stranded wire.

Screw terminal torque 0.5 Nm.

INSTALLATION ON DIN RAIL

To avoid short circuit between the power rail connectors on the DRSL devices and the screws holding the 7.5 mm DIN rail, the head of the screws shall be no more than 3.5 mm high.

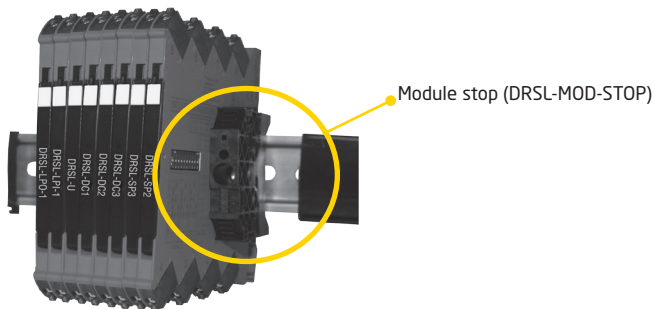
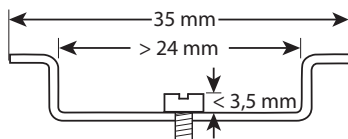

MARKING

The front cover of the DRSL series has been designed with an area for affixation of a click-on marker. The area assigned to the marker measures 5 x 7.5 mm. Markers from Weidmüller's MultiCard System, type MF 5/7.5, are suitable.

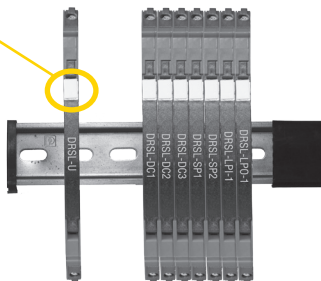

SIDE LABEL

Terminal numbers

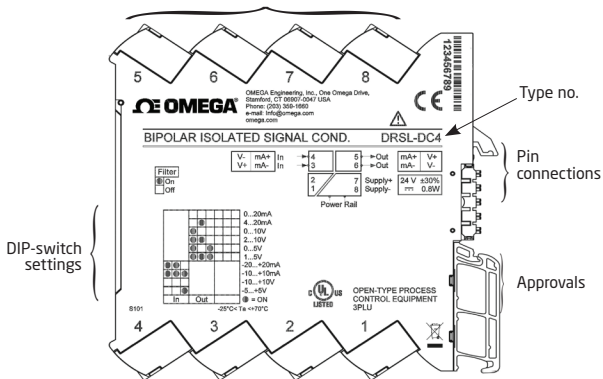

DRSL-DC4: BIPOLAR ISOLATED SIGNAL CONDITIONER

- *Conversion of voltage and current bipolar process signals to unipolar signals*
- *Multiple signal ranges are selectable via DIP-switches*
- *Fast response time and high output load stability*
- *Excellent accuracy, better than 0.05 % of selected range*
- *Slimline 6 mm housing*

Applications

- The DRSL-DC4 is an isolating converter which can be used for signal conversion of standard bipolar analog process signals into a unipolar analog signal.
- The unit offers 3-port isolation and provides surge suppression and protects control systems from transients and noise.
- The DRSL-DC4 also eliminates ground loops and can be used for measuring floating signals.

Technical characteristics

- Flexible 24 VDC ($\pm 30\%$) supply via power rail or connectors.
- Excellent conversion accuracy, better than 0.05% of selected range.
- Inputs and outputs are floating and galvanically separated.
- A green front LED indicate operation status for the device.
- All terminals are protected against overvoltage and polarity error.
- Meeting the NAMUR NE21 recommendations, the DRSL-DC4 ensures top measurement performance in harsh EMC environments.
- High galvanic isolation of 2.5 kVAC.
- Fast response time $< 7 \text{ ms}$ / $> 100 \text{ Hz}$ bandwidth.
– 10 Hz bandwidth damping possible via DIP-switch.
- Excellent signal/noise ratio $> 60 \text{ dB}$.

Mounting / installation

- Fast and easy configuration of factory calibrated measurement ranges via DIP-switches.
- A very low power consumption allows DIN rail mounting with up to 165 units per meter without the need for any air gap.
- Wide temperature operation range: $-25\dots+70^\circ\text{C}$.

Order codes for DRSL-DC4:

Type	Specifications
DRSL-DC4	Bipolar isolated signal conditioner

Accessories for DRSL-DC4:

Type	Function
DRSL-PCU	Power rail connector unit
DRSL-PWR-RAIL	Power rail
DRSL-MOD-STOP	Module stop

Specifications

Environmental conditions:

Specifications range	-25°C to +70°C
Storage temperature	-40°C to +85°C
Calibration temperature	20...28°C
Relative humidity	< 95% RH (non-cond.)
Protection degree	IP20
Installation in pollution degree 2 & measurement / overvoltage category II	

Mechanical specifications:

Dimensions (HxWxD).....	113 x 6.1 x 115 mm
Weight approx.....	70 g
DIN rail type.....	DIN EN 60715 - 35 mm
Wire size	0.13...2.5 mm ² / AWG 26...12 stranded wire
Screw terminal torque	0.5 Nm

Common electrical specifications:

Supply voltage, DC	16.8...31.2 VDC
Internal consumption, typ./max.....	0.4 W / 0.65 W
Power consumption, max.	0.8 W
Isolation voltage, test.....	2.5 kVAC
Working isolation voltage.....	300 VAC
MTBF, acc. to IEC 61709 (SN29500).....	> 241 years
Signal / noise ratio	> 60 dB
Cut-off frequency (3 dB)	> 100 Hz or 10 Hz (selectable via DIP-switch)
Response time (0...90%, 100...10%).....	< 7 ms or < 44 ms

Input specifications:

Current input:

Programmable ranges	± 10 and ± 20 mA
Functional range	-23 ... +23 mA
Input voltage drop	< 1 VDC @ 23 mA

Voltage input:

Programmable ranges	± 5 and ± 10 V
Functional range	-11.5 ... +11.5 V
Input resistance	≥ 1 M Ω

Output specifications:

Current output:

Programmable ranges	0...20 and 4...20 mA
Functional range	0...23 mA
Load (max.)	23 mA / 600 Ω
Load stability	$\leq 0.002\%$ of span / 100 Ω
Current limit	≤ 28 mA

Voltage output:

Programmable ranges	0...5, 1...5, 0...10, 2...10 V
Functional range	0...11.5 V
Load	> 10 k Ω

of span = of the selected range













Accuracy values		
Input type	Absolute accuracy	Temperature coefficient
All	$\leq \pm 0.05\%$ of span	$\leq \pm 0.01\%$ of span / $^{\circ}$ C

EMC immunity influence	< $\pm 0.5\%$ of span
Extended EMC immunity: NAMUR NE 21, A criterion, burst	< $\pm 1\%$ of span

Approvals:

EMC 2004/108/EC	EN 61326-1
LVD 2006/95/EC.....	EN 61010-1
UL, Standard for Safety.....	UL 61010-1
Safe Isolation.....	EN 61140

DIP-switch configuration

Filter ON Bandwidth 10 Hz 	Output Current 0...20 mA 
Filter OFF Bandwidth > 100 Hz 	Output Current 4...20 mA 
Input Current -10...+10 mA 	Output Voltage 0...10 V 
Input Current -20...+20 mA 	Output Voltage 2...10 V 
Input Voltage -5...+5 V 	Output Voltage 0...5 V 
Input Voltage -10...+10 V 	Output Voltage 1...5 V 

DIP-switch positions are only read at power up

Front LED indication (green)

LED	Condition	Output	Action required
OFF	No supply/device error	De-energized	Connect supply/replace device
1 flash 0.5 s ON and OFF	Power-up or Restart	De-energized	-
Flashing 13 Hz / 15 ms ON	Device OK	Energized	-
Flashing 1 Hz / 15 ms ON	Incorrect DIP-sw setting	De-energized	Correct setting and repower
Flashing 13 Hz / 0.5 s ON	Supply or hardware error	De-energized	Check supply/replace device

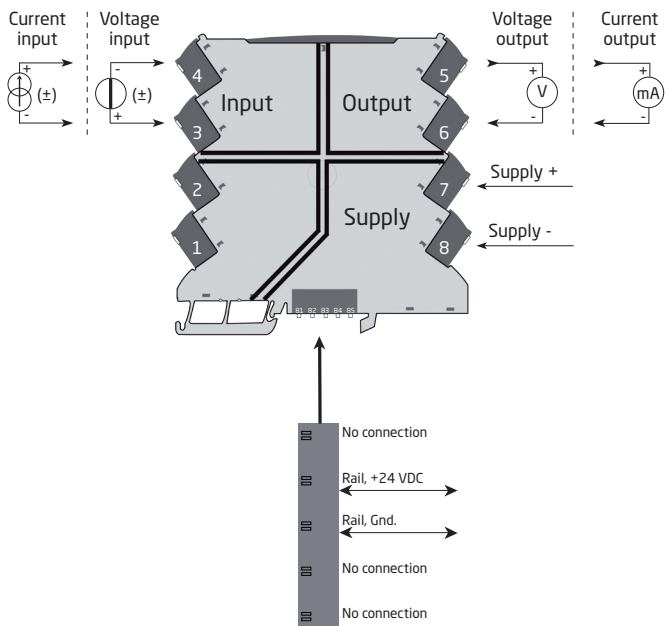

WARRANTY/DISCLAIMER

OMEGA ENGINEERING, INC. warrants this unit to be free of defects in materials and workmanship for a period of **13 months** from date of purchase. OMEGA's Warranty adds an additional one (1) month grace period to the normal **one (1) year product warranty** to cover handling and shipping time. This ensures that OMEGA's customers receive maximum coverage on each product.

If the unit malfunctions, it must be returned to the factory for evaluation. OMEGA's Customer Service Department will issue an Authorized Return (AR) number immediately upon phone or written request. Upon examination by OMEGA, if the unit is found to be defective, it will be repaired or replaced at no charge. OMEGA's WARRANTY does not apply to defects resulting from any action of the purchaser, including but not limited to mishandling, improper interfacing, operation outside of design limits, improper repair, or unauthorized modification. This WARRANTY is VOID if the unit shows evidence of having been tampered with or shows evidence of having been damaged as a result of excessive corrosion; or current, heat, moisture or vibration; improper specification; misapplication; misuse or other operating conditions outside of OMEGA's control. Components in which wear is not warranted, include but are not limited to contact points, fuses, and triacs.

OMEGA is pleased to offer suggestions on the use of its various products. However, OMEGA neither assumes responsibility for any omissions or errors nor assumes liability for any damages that result from the use of its products in accordance with information provided by OMEGA, either verbal or written. OMEGA warrants only that the parts manufactured by the company will be as specified and free of defects. OMEGA MAKES NO OTHER WARRANTIES OR REPRESENTATIONS OF ANY KIND WHATSOEVER, EXPRESSED OR IMPLIED, EXCEPT THAT OF TITLE, AND ALL IMPLIED WARRANTIES INCLUDING ANY WARRANTY OF MERCHANTABILITY AND FITNESS FOR A PARTICULAR PURPOSE ARE HEREBY DISCLAIMED. LIMITATION OF LIABILITY: The remedies of purchaser set forth herein are exclusive, and the total liability of OMEGA with respect to this order, whether based on contract, warranty, negligence, indemnification, strict liability or otherwise, shall not exceed the purchase price of the component upon which liability is based. In no event shall OMEGA be liable for consequential, incidental or special damages.

CONDITIONS: Equipment sold by OMEGA is not intended to be used, nor shall it be used: (1) as a "Basic Component" under 10 CFR 21 (NRC), used in or with any nuclear installation or activity; or (2) in medical applications or used on humans. Should any Product(s) be used in or with any nuclear installation or activity, medical application, used on humans, or misused in any way, OMEGA assumes no responsibility as set forth in our basic WARRANTY/DISCLAIMER language, and, additionally, purchaser will indemnify OMEGA and hold OMEGA harmless from any liability or damage whatsoever arising out of the use of the Product(s) in such a manner.

RETURN REQUESTS/INQUIRIES

Direct all warranty and repair requests/inquiries to the OMEGA Customer Service Department. **BEFORE RETURNING ANY PRODUCT(S) TO OMEGA, PURCHASER MUST OBTAIN AN AUTHORIZED RETURN (AR) NUMBER FROM OMEGA'S CUSTOMER SERVICE DEPARTMENT (IN ORDER TO AVOID PROCESSING DELAYS).** The assigned AR number should then be marked on the outside of the return package and on any correspondence. The purchaser is responsible for shipping charges, freight, insurance and proper packaging to prevent breakage in transit.

FOR **WARRANTY** RETURNS, please have the following information available BEFORE contacting OMEGA:

1. Purchase Order number under which the product was PURCHASED,
2. Model and serial number of the product under warranty, and
3. Repair instructions and/or specific problems relative to the product.

FOR **NON-WARRANTY** REPAIRS, consult OMEGA for current repair charges. Have the following information available BEFORE contacting OMEGA:

1. Purchase Order number to cover the COST of the repair,
2. Model and serial number of the product, and
3. Repair instructions and/or specific problems relative to the product.

OMEGA's policy is to make running changes, not model changes, whenever an improvement is possible. This affords our customers the latest in technology and engineering.

OMEGA is a registered trademark of OMEGA ENGINEERING, INC.

© Copyright 2014 OMEGA ENGINEERING, INC. All rights reserved. This document may not be copied, photocopied, reproduced, translated, or reduced to any electronic medium or machine-readable form, in whole or in part, without the prior written consent of OMEGA ENGINEERING, INC.

Where Do I Find Everything I Need for Process Measurement and Control? **OMEGA...Of Course!**

Shop online at omega.comSM

TEMPERATURE

- ☑ Thermocouple, RTD & Thermistor Probes, Connectors, Panels & Assemblies
- ☑ Wire: Thermocouple, RTD & Thermistor
- ☑ Calibrators & Ice Point References
- ☑ Recorders, Controllers & Process Monitors
- ☑ Infrared Pyrometers

PRESSURE, STRAIN AND FORCE

- ☑ Transducers & Strain Gages
- ☑ Load Cells & Pressure Gages
- ☑ Displacement Transducers
- ☑ Instrumentation & Accessories

FLOW/LEVEL

- ☑ Rotameters, Gas Mass Flowmeters & Flow Computers
- ☑ Air Velocity Indicators
- ☑ Turbine/Paddlewheel Systems
- ☑ Totalizers & Batch Controllers

pH/CONDUCTIVITY

- ☑ pH Electrodes, Testers & Accessories
- ☑ Benchtop/Laboratory Meters
- ☑ Controllers, Calibrators, Simulators & Pumps
- ☑ Industrial pH & Conductivity Equipment

DATA ACQUISITION

- ☑ Data Acquisition & Engineering Software
- ☑ Communications-Based Acquisition Systems
- ☑ Plug-in Cards for Apple, IBM & Compatibles
- ☑ Data Logging Systems
- ☑ Recorders, Printers & Plotters

HEATERS

- ☑ Heating Cable
- ☑ Cartridge & Strip Heaters
- ☑ Immersion & Band Heaters
- ☑ Flexible Heaters
- ☑ Laboratory Heaters

ENVIRONMENTAL MONITORING AND CONTROL

- ☑ Metering & Control Instrumentation
- ☑ Refractometers
- ☑ Pumps & Tubing
- ☑ Air, Soil & Water Monitors
- ☑ Industrial Water & Wastewater Treatment
- ☑ pH, Conductivity & Dissolved Oxygen Instruments