

1 YEAR  
WARRANTY

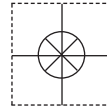

# Ω OMEGA® User's Guide



HX93BD WALL MOUNT



HX93BD(\*)-D DUCT MOUNT

**Shop online at  
[omega.com](http://omega.com)®**

**e-mail: [info@omega.com](mailto:info@omega.com)  
For latest product manuals:  
[www.omegamanual.info](http://www.omegamanual.info)**

EASY M12  
CONNECTION



HX93B(\*)



TH-RP remote  
probe with 3 m  
(10') cable and  
M12 connector.

## HX93B SERIES Temperature/Relative Humidity Transmitters



omega.com info@omega.com

**Servicing North America:**

**U.S.A.:**

Omega Engineering, Inc., One Omega Drive, P.O. Box 4047  
Stamford, CT 06907-0047 USA  
Toll-Free: 1-800-826-6342 (USA & Canada only)  
Customer Service: 1-800-622-2378 (USA & Canada only)  
Engineering Service: 1-800-872-9436 (USA & Canada only)  
Tel: (203) 359-1660 Fax: (203) 359-7700  
e-mail: info@omega.com

**For Other Locations Visit [omega.com/worldwide](http://omega.com/worldwide)**

---

The information contained in this document is believed to be correct, but OMEGA accepts no liability for any errors it contains, and reserves the right to alter specifications without notice.

**WARNING:** These products are not designed for use in, and should not be used for, human applications.

**Patented:** Covered by U.S. and International Patents and Patents Pending.



## Table of Contents

Section	Page
1. General Description .....	1-1
2. Unpacking .....	2-1
3. Electrical Connection and Temperature Measuring Range Selection .....	3-1
3.1 Electrical Connection .....	3-1
3.2 Temperature Measuring Range Selection .....	3-1
4. Mounting .....	4-1
5. Temperature Output Calculations .....	5-1
6. Relative Humidity Output Calculations .....	6-1
7. Calibration .....	7-1
8. Maintenance .....	8-1
9. Specifications .....	9-1



## List of Figures

Figure	Description	Page
Figure 1-1	Transmitter Internal Diagram .....	1-1
Figure 3-1	Electrical Connection Diagram .....	3-1
Figure 3-2	Temperature Measuring Range Selection Diagram .....	3-1
Figure 4-1	Wall Mount Model Dimensions .....	4-1
Figure 4-2	Duct Mount Model Dimensions .....	4-2
Figure 4-3	Remote Probe Model Dimensions .....	4-2
Figure 8-1	Sensor Probe Replacement .....	8-1

## Section 1 - General Description

The OMEGA® HX93B and HX93BD Series Temperature/Relative Humidity Transmitters provides a linearized and temperature compensated output signal of 4 to 20mA, 0 to 1 Vdc, 0 to 5 Vdc or 0 to 10 Vdc depending upon the model selected for both temperature/relative humidity measurement. The output signals have been calibrated and scaled  $-30^{\circ}\text{C}$  to  $75^{\circ}\text{C}$  for temperature and 0 to 100% for relative humidity. The digital temperature and relative humidity sensor is protected by a stainless steel filter that is easily removed for cleaning. The NEMA rated polycarbonate enclosure and cable entry connection provides weathertight protection. Screws are provided for mounting via internal holes inside the enclosure.

The HX93BD Series has a dual display with backlit to display both Temperature and Relative Humidity readings. An on-board slide switch allows the user to change the temperature reading from  $^{\circ}\text{C}$  to  $^{\circ}\text{F}$  as shown in figure 1-1 below.

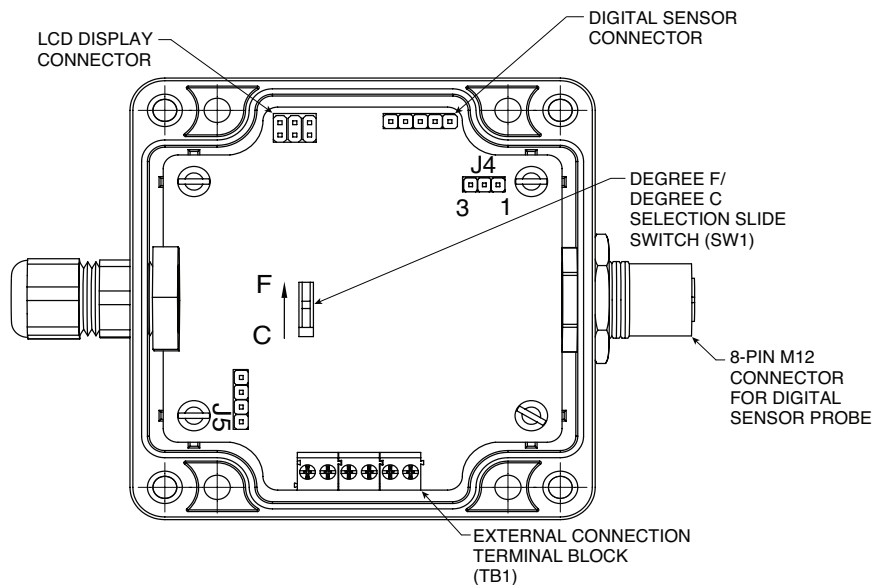

Figure 1-1. Transmitter Internal Diagram

Most of the models come with a replaceable sensor probe; the process of replacing the sensor probe is very simple using an M12 connector. See the "Maintenance" section for details.

**The models with a replaceable Sensor Probe are:**

HX93BDC, HX93BDV0, HX93BDV1, HX93BDV2, HX93BDC-RP1, HX93BDV0-RP1, HX93BDV1-RP1, HX93BDV2-RP1, HX93BC, HX93BV0, HX93BV1, HX93BV2, HX93BC-RP1, HX93BV0-RP1, HX93BV1-RP1, HX93BV2-RP1.

**The models without a replaceable sensor probe are:**

HX93BDC-D, HX93BDV0-D, HX93BDV1-D, HX93BDV2-D, HX93BC-D, HX93BV0-D, HX93BV1-D, HX93BV2-D.

## Section - 2 Unpacking

Remove the packing list and verify that you have received all your equipment. If you have any questions about the shipment, please call our Customer Service Department at

1-800-622-2378 or 203-359-1660. On the web you can find us at:

www.omega.com      e-mail: cservice@omega.com

When you receive the shipment, inspect the container and equipment for any signs of damage. Note any evidence of rough handling in transit. Immediately report any damage to the shipping agent.

---

**NOTE:**

The carrier will not honor any damage claims unless all shipping material is saved for inspection. After examining and removing contents, save packing material and carton in the event reshipment is necessary.

---

The following items are supplied in the box with your HX93B Series transmitter.

- HX93B Series Quick Start Manual, MQS5340 (1 ea.)
- #6 Wall Anchor and #6 Mounting Screw (2 ea.)
- Dew point Card (1 ea.)

## 2.1 HX93B available models and functional description

Model number	Description
<b>HX93BDC</b>	Digital Display Wall Mount Temperature/Relative Humidity Transmitter, 4 to 20mA.
<b>HX93BDV0</b>	Digital Display Wall Mount Temperature/Relative Humidity Transmitter, 0 to 1 volt.
<b>HX93BDV1</b>	Digital Display Wall Mount Temperature/Relative Humidity Transmitter, 0 to 5 volt.
<b>HX93BDV2</b>	Digital Display Wall Mount Temperature/Relative Humidity Transmitter, 0 to 10 volt.
<b>HX93BDC-D</b>	Digital Display Duct Mount Temperature/Relative Humidity Transmitter, 4 to 20mA.
<b>HX93BDV0-D</b>	Digital Display Duct Mount Temperature/Relative Humidity Transmitter, 0 to 1 volt.
<b>HX93BDV1-D</b>	Digital Display Duct Mount Temperature/Relative Humidity Transmitter, 0 to 5 volt.
<b>HX93BDV2-D</b>	Digital Display Duct Mount Temperature/Relative Humidity Transmitter, 0 to 10 volt.
<b>HX93BDC-RP1</b>	Digital Display Remote Probe Temperature/Relative Humidity Transmitter, 4 to 20mA Output with 3 m (10') cable.
<b>HX93BDV0-RP1</b>	Digital Display Remote Probe Temperature/Relative Humidity Transmitter, 0 to 1 volt output with 3 m (10') cable.
<b>HX93BDV1-RP1</b>	Digital Display Remote Probe Temperature/Relative Humidity Transmitter, 0 to 5 volt out put with 3 m (10') cable.
<b>HX93BDV2-RP1</b>	Digital Display Remote Probe Temperature/Relative Humidity Transmitter, 0 to 10 volt output with 3 m (10') cable.
<b>HX93BC</b>	Wall Mount Temperature/Relative Humidity Transmitter, 4 to 20mA.
<b>HX93BV0</b>	Wall Mount Temperature/Relative Humidity Transmitter, 0 to 1 volt.
<b>HX93BV1</b>	Wall Mount Temperature/Relative Humidity Transmitter, 0 to 5 volt.
<b>HX93BV2</b>	Wall Mount Temperature/Relative Humidity Transmitter, 0 to 10 volt.
<b>HX93BC-D</b>	Duct Mount Temperature/Relative Humidity Transmitter, 4 to 20mA.
<b>HX93BV0-D</b>	Duct Mount Temperature/Relative Humidity Transmitter, 0 to 1 volt.
<b>HX93BV1-D</b>	Duct Mount Temperature/Relative Humidity Transmitter, 0 to 5 volt.
<b>HX93BV2-D</b>	Duct Mount Temperature/Relative Humidity Transmitter, 0 to 10 volt.
<b>HX93BC-RP1</b>	Remote Probe Temperature/Relative Humidity Transmitter, 4 to 20mA output with 3m (10') cable.
<b>HX93BV0-RP1</b>	Remote Probe Temperature/Relative Humidity Transmitter, 4 to 20mA output with 3m (10') cable.
<b>HX93BV1-RP1</b>	Remote Probe Temperature/Relative Humidity Transmitter, 4 to 20mA output with 3m (10') cable.
<b>HX93BV2-RP1</b>	Remote Probe Temperature/Relative Humidity Transmitter, 4 to 20mA output with 3m (10') cable.
<b>TH-RP</b>	Field replaceable remote probe with 3 m (10') cable and M12 connector.
<b>TH-SP</b>	Field replaceable 71.88 L mm (2.83") short probe with M12 connector.
<b>HX92-CAL</b>	Calibration Kit and 75% relative humidity standards.
<b>IND-KIT</b>	Spare duct mount kit for HX93B(*)-D, HX93B(*)-RP1, HX93BD(*)-D, HX93BD(*)-RP1

## Section 3 – Electrical Connection and Temperature Measuring Range Selection

### NOTE:

All electrical connections and wiring should be performed by a suitably trained professional only.

### 3.1 Electrical Connection

Follow the electrical connection diagram shown in figure 3-1 below to set up your Temperature/Relative Humidity Transmitter.

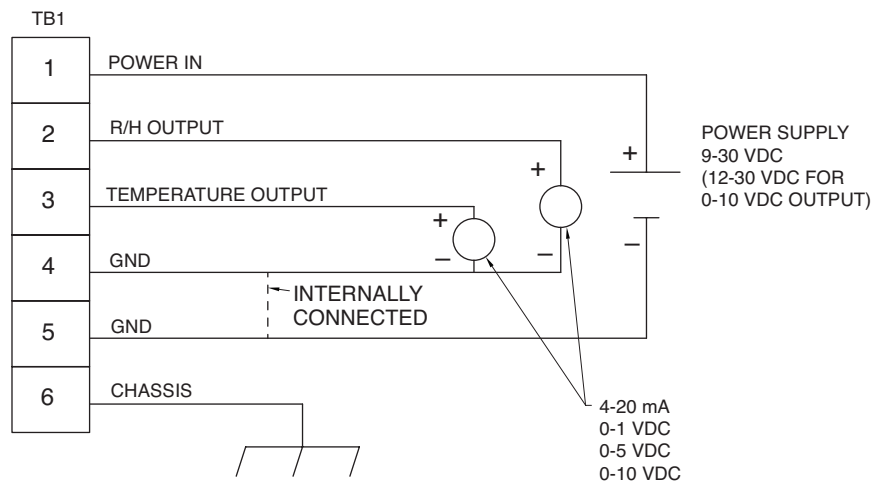

Figure 3-1 Electrical Connection Diagram

### 3.2 Temperature Measuring Range Selection:

The temperature measuring range of the HX93B can be modified by making a minor change to a connector J4. The standard temperature measuring range is  $-30$  to  $75^{\circ}\text{C}$  ( $-22$  to  $167^{\circ}\text{F}$ ) without adding any jumper on connector J4. If you would like to change the range to  $-20$  to  $75^{\circ}\text{C}$  ( $-4$  to  $167^{\circ}\text{F}$ ), add a jumper on connector J4 pin 1 to pin 2. See the diagram below for the location of the connector and its pins.

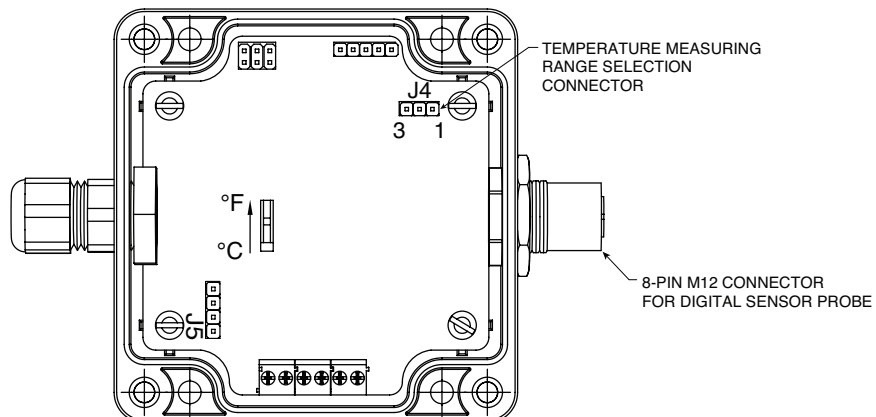

Figure 3-2 Temperature Measuring Range Selection Diagram



## Section 4 - Mounting

The HX93B and HX93BD series transmitters are designed for wall, duct or remote probe mounting depending upon the model. Plastic wall anchors and mounting screws are included for wall mounting and remote probe models. A duct mounting kit is included with duct mount models.

See figure 4-1, figure 4-2 and figure 4-3 for the wall mount, duct mount and remote probe model dimension for your mounting reference.

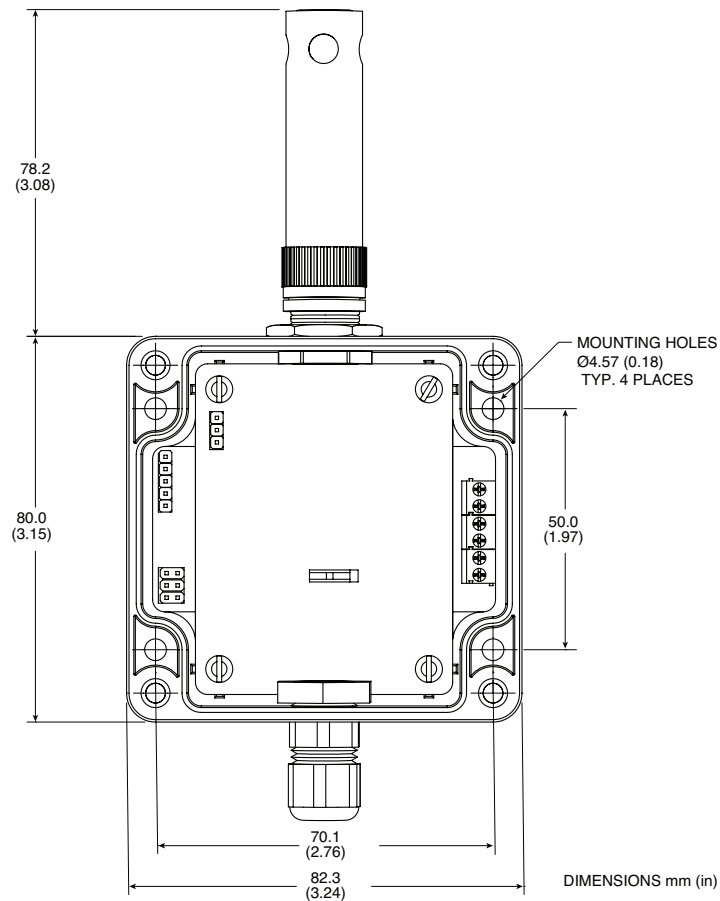

Figure 4-1 Wall Mount Model Dimensions

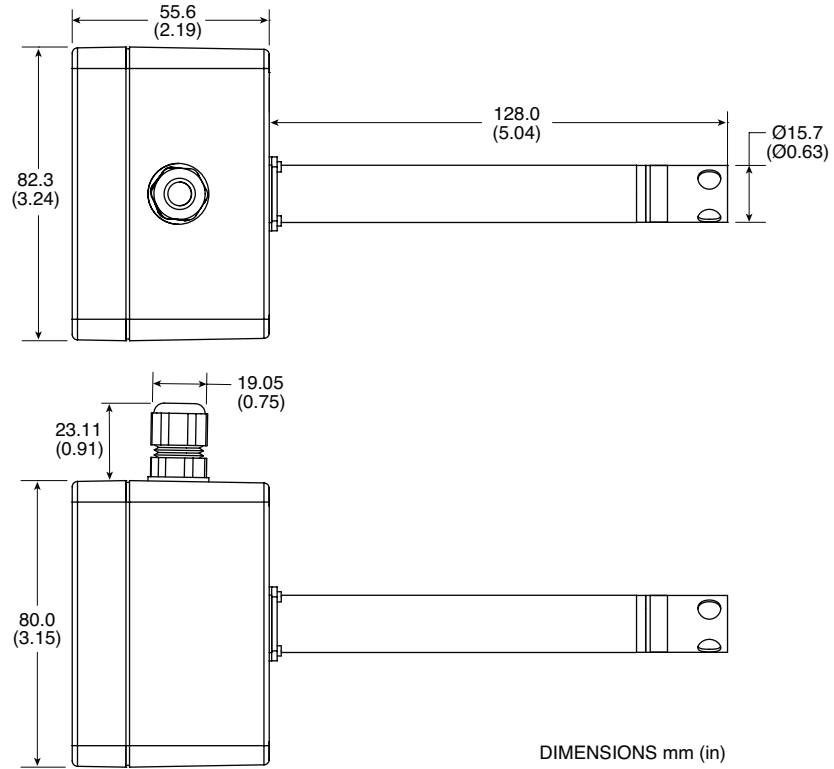

Figure 4-2 Duct Mount Model Dimensions

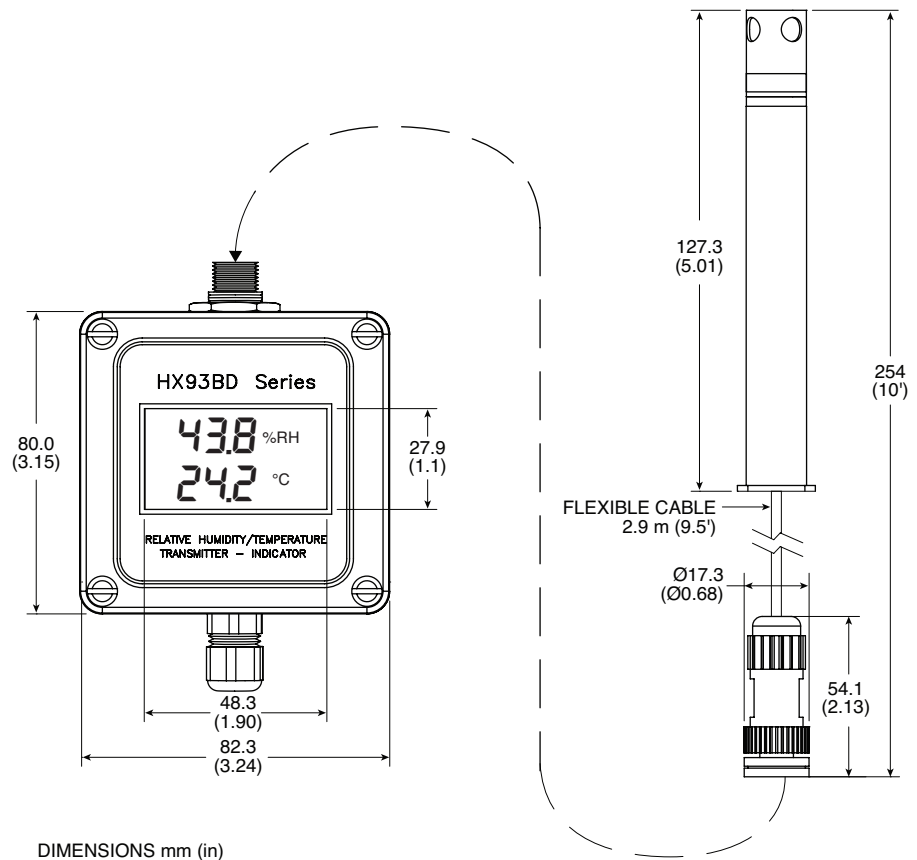

Figure 4-3 Remote Probe Model Dimensions

## Section 5 - Temperature Output Calculations

To calculate Temperature by measuring the current or voltage output, use the following formulas.

- a) To calculate temperature in °C from a 4 to 20mA current output in °C for the temperature range of -30 to 75°C**

Formula:

$$\text{Temperature in } ^\circ\text{C} = [(\text{Output current measured in milliamp} - 4) \div (0.1524)] - 30$$

Where: 4 = Offset current in mA

30 = Offset temperature in °C

0.1524 is the sensitivity, which derived from the following:

(Full scale current limit)/(total temperature range)

$$16 \text{ mA} / 105^\circ\text{C} = 0.1524\text{mA}/^\circ\text{C}$$

- b) To Calculate temperature in °F from a 4 to 20mA current output in °F for the temperature range of -22 to 167°F**

Formula:

$$\text{Temperature in } ^\circ\text{F} = (\text{Output current measured in milliamps} - 4) \div (0.0847)] - 22$$

Where 4 = Offset current in mA

22 = Offset temperature in °F

0.0847 is the sensitivity, which derived from the following:

(Full scale current limit)/(total temperature range)

$$16 \text{ mA} / 189^\circ\text{F} = 0.0847\text{mA}/^\circ\text{F}$$

- c) To calculate temperature in °C from a 0 to 1 volt output for the temperature range of -30 to 75°C**

Formula:

$$\text{Temperature in } ^\circ\text{C} = (\text{Output voltage measured} \div 0.0095) - 30$$

Where: 30 = offset temperature in °C

0.0095 is sensitivity, which derived from the following:

(Total out put voltage range)/(out temperature range)

$$1.0 \text{ v} / 105^\circ\text{C} = 0.0095 \text{ V}/^\circ\text{C}$$

- d) To calculate temperature in °F for 0 to 1 volt output for the temperature range of -22°F to 167°F**

Formula:

$$\text{Temperature in } ^\circ\text{F} = (\text{Output measured in volts} \div 0.0053) - 22$$

Where 22 = Offset temperature in °F

0.0053 is sensitivity, which derived from the following:

(Total out put voltage range)/(out temperature range)

$$1.0 \text{ v} / 189^\circ\text{F} = 0.0053 \text{ V}/^\circ\text{F}$$

The same calculation method will apply to the 0 to 5 volt and 0 to 10 volts models.

**e) To calculate temperature in °C from a 0 to 5 volt output for the temperature range of -30 to 75°C**

Formula:

$$\text{Temperature in } ^\circ\text{C} = (\text{Output voltage measured} \div 0.0476) - 30$$

Where: 30 = offset temperature in °C

0.0476 is sensitivity, which derived from the following:

$$(\text{Total out put voltage range}) / (\text{out temperature range})$$

$$5.0 \text{ v} / 105^\circ\text{C} = 0.0476 \text{ V}/^\circ\text{C}$$

**f) To calculate temperature in °F for 0 to 5 volt output for the temperature range of -22°F to 167°F**

Formula:

$$\text{Temperature in } ^\circ\text{F} = (\text{Output measured in volts} \div 0.0265) - 22$$

Where 22 = Offset temperature in °F

0.0265 is sensitivity, which derived from the following:

$$(\text{Total out put voltage range}) / (\text{out temperature range})$$

$$5.0 \text{ v} / 189^\circ\text{F} = 0.0265 \text{ V}/^\circ\text{F}$$

**g) To calculate temperature in °C from a 0 to 10 volt output for the temperature range of -30 to 75°C**

Formula:

$$\text{Temperature in } ^\circ\text{C} = (\text{Output voltage measured} \div 0.0952) - 30$$

Where: 30 = offset temperature in °C

0.0952 is sensitivity, which derived from the following:

$$(\text{Total out put voltage range}) / (\text{out temperature range})$$

$$10.0 \text{ v} / 105^\circ\text{C} = 0.0952 \text{ V}/^\circ\text{C}$$

**h) To calculate temperature in °F for 0 to 10 volt output for the temperature range of -22°F to 167°F**

Formula:

$$\text{Temperature in } ^\circ\text{F} = (\text{Output measured in volts} \div 0.0529) - 22$$

Where 22 = Offset temperature in °F

0.0529 is sensitivity, which derived from the following:

$$(\text{Total out put voltage range}) / (\text{out temperature range})$$

$$10.0 \text{ v} / 189^\circ\text{F} = 0.0529 \text{ V}/^\circ\text{F}$$

## Section 6 - Relative Humidity Output Calculations

To calculate % Relative Humidity by measuring the current or voltage output, use the following formulas.

For current output:

$$\%RH = (\text{Current measured in milliamps} - 4) \div 0.16$$

Where:

4 = offset current in mA.

0.16 = Full scale current limit in percent (%).

For voltage output:

Formula:  $\%RH = (\text{voltage measured in volts}) \times 100$

a) 1 volt output

$$\%RH = (\text{voltage measured in volts}) \times 100$$

b) 5 volts output:

$$\%RH = (\text{voltage measured in volts} / 5) \times 100$$

c) 10 volts output:

$$\%RH = (\text{voltage measured in volts} / 10) \times 100$$

**Section 7 - Calibration**

Your transmitter has been digitally calibrated and tested to meet or exceed the specifications outlined in this manual in our factory. The transmitter must be sent back to the factory for any re-calibration request.

## Section 8 - Maintenance

The Sensor can be replaced quickly for the wall mount and remote models.

Procedure to replace the Sensor:

- a. Loosen up the Sensor Probe nut, and pull out the sensor probe.
- b. Insert the new sensor probe to the M12 connector, and tighten the secure nut to secure the connection.

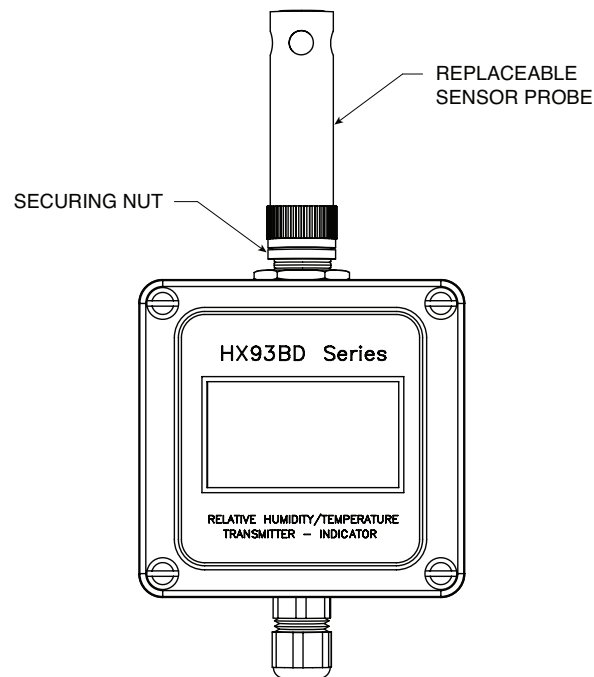

Figure 8-1 Sensor Probe Replacement

If your Humidity transmitter is used in a dusty environment, the protective sensor filter (if clogged) may be removed for cleaning.

Unscrew the protective cover and gently blow compressed air through the filter screen. A soft brush may also be used to remove dirt particles from the screen.

If the sensor is subjected to 100% condensation, it must be dried to obtain correct readings. There will be no permanent damage or calibration shift to the unit.

Units should not be exposed to high concentrations of ammonia or alcohol vapors.

**For the Duct mount model Transmitter, it must be sent back to factory for sensor re-placement and re-calibration.**

## Section 9 - Specifications

### TEMPERATURE

#### Measuring Range

##### Standard:

-30 to 75°C (-22 °F to 167°F) without jumper on connector J4

##### Special:

-20 to 75°C (-4 to 167°F) with jumper added on connector J4 pin 1 to 2. See figure 3-2.

#### Accuracy:

±0.6°C from 0 to 50°C (32 to 122°F),  
±1.25°C from -30 to 0°C (-22 to 32°F) and  
50 to 75°C (122 to 167°F)

#### Repeatability:

±0.2°C (0.4°F)

#### Resolution:

0.1°C

#### Response Time:

5 Seconds min., 30 seconds max.

#### Sample Rate:

1 Sample every 4 seconds

### RELATIVE HUMIDITY

#### Measuring Range:

0 to 100%

#### Accuracy Range:

±2.5 % from 20 to 80% RH, ±3.5% from 5 to 20%  
and 80 to 95% RH, ±4% from 0 to 5% and 95 to  
100% RH

#### Hysteresis:

±1%

#### Repeatability:

±0.1%

#### Resolution:

0.1%

#### Response Time:

8 Seconds typical

#### Sample Rate:

1 Sample every 4 seconds

#### Operating Temperature Range:

-30 to 75°C

#### Input Power:

9 to 30 Vdc @ 100mA:  
4 to 20mA, 0-1 volt, 0-5 volt output  
12 to 30 Vdc @ 100mA:  
0 to 10 volts output

#### Max Loop Resistance: (4 to 20 mA Output)

200 Ohms @ 9 Vdc supply voltage  
1,250 Ohms @ 30 Vdc supply  
voltage Ohms = [(V supply - 4V) / 0.02A] - 50

#### Max. Load Resistance: (min. resistance)

1.25 K (For all outputs: 0-1 Vdc, 0-5 Vdc,  
0-10 Vdc)

#### Sensor Type:

Digital Sensor

#### Enclosure Housing:

Gray Polycarbonate,  
NEMA 13 (IP54)



---

<b>Connections</b>	Liquid-tight nylon with neoprene gland, for 2.50 to 8.00 mm (0.09 to 0.315") diameter cable, internal 6 position terminal block accepts 14 to 22 gauge wire
<b>Dimensions:</b>	See "Mounting" Section
<b>Weight:</b>	
HX93B (*):	151 g (8.9 oz)
HX93B (*) - D:	256 g (9.0 oz)
HX93B (*) - RP1:	352 g (12.4 oz)
<b>Display (HX93BD Series only)</b>	
<b>Indicator:</b>	Two 4 digit digital back-lit LCD
<b>Display:</b>	1 Reading per second

\*4 to 20 mA, 0-1 volt, 0-5 volts, or 0-10 volts output. See page 2.2 for model number information.

## WARRANTY/DISCLAIMER

OMEGA ENGINEERING, INC. warrants this unit to be free of defects in materials and workmanship for a period of **13 months** from date of purchase. OMEGA's WARRANTY adds an additional one (1) month grace period to the normal **one (1) year product warranty** to cover handling and shipping time. This ensures that OMEGA's customers receive maximum coverage on each product.

If the unit malfunctions, it must be returned to the factory for evaluation. OMEGA's Customer Service Department will issue an Authorized Return (AR) number immediately upon phone or written request. Upon examination by OMEGA, if the unit is found to be defective, it will be repaired or replaced at no charge. OMEGA's WARRANTY does not apply to defects resulting from any action of the purchaser, including but not limited to mishandling, improper interfacing, operation outside of design limits, improper repair, or unauthorized modification. This WARRANTY is VOID if the unit shows evidence of having been tampered with or shows evidence of having been damaged as a result of excessive corrosion; or current, heat, moisture or vibration; improper specification; misapplication; misuse or other operating conditions outside of OMEGA's control. Components in which wear is not warranted, include but are not limited to contact points, fuses, and triacs.

**OMEGA is pleased to offer suggestions on the use of its various products. However, OMEGA neither assumes responsibility for any omissions or errors nor assumes liability for any damages that result from the use of its products in accordance with information provided by OMEGA, either verbal or written. OMEGA warrants only that the parts manufactured by the company will be as specified and free of defects. OMEGA MAKES NO OTHER WARRANTIES OR REPRESENTATIONS OF ANY KIND WHATSOEVER, EXPRESSED OR IMPLIED, EXCEPT THAT OF TITLE, AND ALL IMPLIED WARRANTIES INCLUDING ANY WARRANTY OF MERCHANTABILITY AND FITNESS FOR A PARTICULAR PURPOSE ARE HEREBY DISCLAIMED. LIMITATION OF LIABILITY: The remedies of purchaser set forth herein are exclusive, and the total liability of OMEGA with respect to this order, whether based on contract, warranty, negligence, indemnification, strict liability or otherwise, shall not exceed the purchase price of the component upon which liability is based. In no event shall OMEGA be liable for consequential, incidental or special damages.**

CONDITIONS: Equipment sold by OMEGA is not intended to be used, nor shall it be used: (1) as a "Basic Component" under 10 CFR 21 (NRC), used in or with any nuclear installation or activity; or (2) in medical applications or used on humans. Should any Product(s) be used in or with any nuclear installation or activity, medical application, used on humans, or misused in any way, OMEGA assumes no responsibility as set forth in our basic WARRANTY/DISCLAIMER language, and, additionally, purchaser will indemnify OMEGA and hold OMEGA harmless from any liability or damage whatsoever arising out of the use of the Product(s) in such a manner.

## RETURN REQUESTS/INQUIRIES

Direct all warranty and repair requests/inquiries to the OMEGA Customer Service Department. BEFORE RETURNING ANY PRODUCT(S) TO OMEGA, PURCHASER MUST OBTAIN AN AUTHORIZED RETURN (AR) NUMBER FROM OMEGA'S CUSTOMER SERVICE DEPARTMENT (IN ORDER TO AVOID PROCESSING DELAYS). The assigned AR number should then be marked on the outside of the return package and on any correspondence.

The purchaser is responsible for shipping charges, freight, insurance and proper packaging to prevent breakage in transit.

FOR **WARRANTY** RETURNS, please have the following information available BEFORE contacting OMEGA:

1. Purchase Order number under which the product was PURCHASED,
2. Model and serial number of the product under warranty, and
3. Repair instructions and/or specific problems relative to the product.

FOR **NON-WARRANTY** REPAIRS, consult OMEGA for current repair charges. Have the following information available BEFORE contacting OMEGA:

1. Purchase Order number to cover the COST of the repair,
2. Model and serial number of the product, and
3. Repair instructions and/or specific problems relative to the product.

OMEGA's policy is to make running changes, not model changes, whenever an improvement is possible. This affords our customers the latest in technology and engineering.

OMEGA is a registered trademark of OMEGA ENGINEERING, INC.

© Copyright 2014 OMEGA ENGINEERING, INC. All rights reserved. This document may not be copied, photocopied, reproduced, translated, or reduced to any electronic medium or machine-readable form, in whole or in part, without the prior written consent of OMEGA ENGINEERING, INC.

# Where Do I Find Everything I Need for Process Measurement and Control? **OMEGA...Of Course!** *Shop online at [omega.com](http://omega.com)<sup>SM</sup>*

## **TEMPERATURE**

- ☑ Thermocouple, RTD & Thermistor Probes, Connectors, Panels & Assemblies
- ☑ Wire: Thermocouple, RTD & Thermistor
- ☑ Calibrators & Ice Point References
- ☑ Recorders, Controllers & Process Monitors
- ☑ Infrared Pyrometers

## **PRESSURE, STRAIN AND FORCE**

- ☑ Transducers & Strain Gages
- ☑ Load Cells & Pressure Gages
- ☑ Displacement Transducers
- ☑ Instrumentation & Accessories

## **FLOW/LEVEL**

- ☑ Rotameters, Gas Mass Flowmeters & Flow Computers
- ☑ Air Velocity Indicators
- ☑ Turbine/Paddlewheel Systems
- ☑ Totalizers & Batch Controllers

## **pH/CONDUCTIVITY**

- ☑ pH Electrodes, Testers & Accessories
- ☑ Benchtop/Laboratory Meters
- ☑ Controllers, Calibrators, Simulators & Pumps
- ☑ Industrial pH & Conductivity Equipment

## **DATA ACQUISITION**

- ☑ Data Acquisition & Engineering Software
- ☑ Communications-Based Acquisition Systems
- ☑ Plug-in Cards for Apple, IBM & Compatibles
- ☑ Data Logging Systems
- ☑ Recorders, Printers & Plotters

## **HEATERS**

- ☑ Heating Cable
- ☑ Cartridge & Strip Heaters
- ☑ Immersion & Band Heaters
- ☑ Flexible Heaters
- ☑ Laboratory Heaters

## **ENVIRONMENTAL MONITORING AND CONTROL**

- ☑ Metering & Control Instrumentation
- ☑ Refractometers
- ☑ Pumps & Tubing
- ☑ Air, Soil & Water Monitors
- ☑ Industrial Water & Wastewater Treatment
- ☑ pH, Conductivity & Dissolved Oxygen Instruments