

User's Guide



Shop online at

omega.com[®]

Ω OMEGA[®]

omega.com

e-mail: info@omega.com

*For latest product manuals:
omegamanual.info*

ISO 9001
CERTIFIED
CORPORATE QUALITY

STAMFORD, CT

ISO 9002
CERTIFIED
CORPORATE QUALITY

MANCHESTER, UK

FTB-1300 Series **Turbine Flow Meters**



OMEGAnet® Online Service
omega.com

Internet e-mail
info@omega.com

Servicing North America:

U.S.A.:
ISO 9001 Certified

One Omega Drive, Box 4047
Stamford, CT 06907-0047
Tel: (203) 359-1660
FAX: (203) 359-7700
e-mail: info@omega.com

Canada:

976 Bergar
Laval (Quebec) H7L 5A1, Canada
Tel: (514) 856-6928
FAX: (514) 856-6886
e-mail: info@omega.ca

For immediate technical or application assistance:

U.S.A. and Canada: Sales Service: 1-800-826-6342/1-800-TC-OMEGA®
Customer Service: 1-800-622-2378/1-800-622-BEST®
Engineering Service: 1-800-872-9436/1-800-USA-WHEN®

Mexico:

En Español: (001) 203-359-7803
e-mail: espanol@omega.com
FAX: (001) 203-359-7807
info@omega.com.mx

Servicing Europe:

Czech Republic:

Frystatska 184, 733 01 Karviná, Czech Republic
Tel: +420 (0)59 6311899
FAX: +420 (0)59 6311114
Toll Free: 0800-1-66342
e-mail: info@omegashop.cz

Germany/Austria:

Daimlerstrasse 26, D-75392 Deckenpfronn, Germany
Tel: +49 (0)7056 9398-0
FAX: +49 (0)7056 9398-29
Toll Free in Germany: 0800 639 7678
e-mail: info@omega.de

United Kingdom:
ISO 9002 Certified

One Omega Drive, River Bend Technology Centre
Northbank, Irlam, Manchester
M44 5BD United Kingdom
Tel: +44 (0)161 777 6611
FAX: +44 (0)161 777 6622
Toll Free in United Kingdom: 0800-488-488
e-mail: sales@omega.co.uk

It is the policy of OMEGA Engineering, Inc. to comply with all worldwide safety and EMC/EMI regulations that apply. OMEGA is constantly pursuing certification of its products to the European New Approach Directives. OMEGA will add the CE mark to every appropriate device upon certification.

The information contained in this document is believed to be correct, but OMEGA accepts no liability for any errors it contains, and reserves the right to alter specifications without notice.

WARNING: These products are not designed for use in, and should not be used for, human applications.

FTB-1300 Series - Turbine Flow Meters

General Description	2
Installation Instructions	3
Operational Start Up	4
Trouble Shooting Guide	5
Repair Kit Information	6
Installation and Technical Data Guide	7-8
FTB-1301 through FTB-1308	
Installation and Technical Data Guide	9-10
FTB-1311 through FTB-1318	



FTB-1300 Series Turbine Flow Meter

General Description:

The FTB-1300 series of turbine flow meters is designed with a wear resistant rotor assembly to provide trouble free operation and a long service life. Fluid moving through the flow meter causes the rotor to turn at a speed proportional to the flow rate, and as the rotor blades cut through the magnetic field of the pickup, an electronic pulse is generated.

The pulse train is used to represent the actual flow or total amount of fluid passing through the flow meter. The number of electronic pulses generated per unit volume is known as a K-factor. The value is constant over each flow meter's operating range, and is unique to each meter.

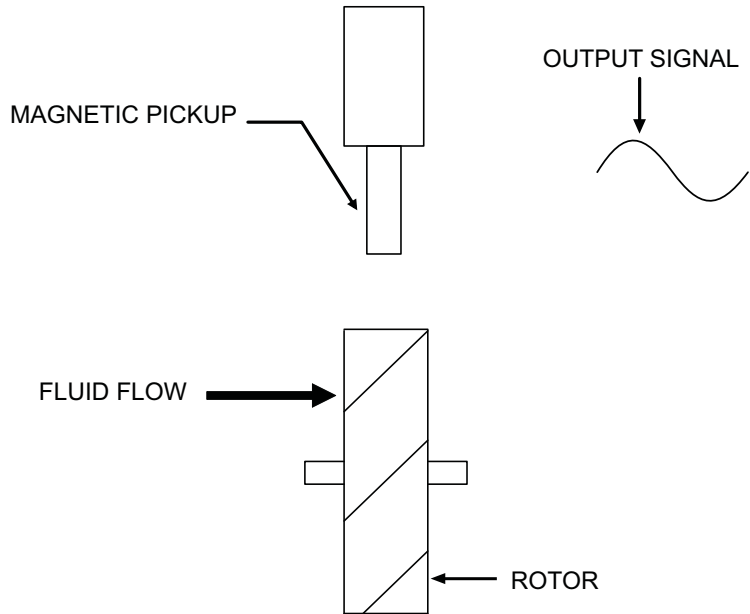

Operating Limitations of the FTB-1300 Series Turbine Flow Meters:

- 1) **Pressure** - 5,000 PSI max

WARNING: Pressure in excess of allowable rating may cause the housing to burst and cause serious personal injury.

- 2) **Corrosion** - The internal parts of the meter are constructed of stainless steel (316L & 1.4122) and carbide with nickel binder. Be sure that the operating fluid is compatible with these materials. Incompatible fluids will deteriorate internal parts, and cause the meter to read inaccurately.
- 3) **Pulsation** - Severe pulsation will affect accuracy, and shorten the life of your meter.
- 4) **Vibration & Shock** - Severe mechanical vibration may decrease service life of the meter.
- 5) **Filtration** - A strainer should be installed upstream of the meter if small particles are present (see Table 1 for filtration requirements)

Installation Instructions:

Before installation, the flow meter should be checked internally for foreign material and to ensure that the rotor spins freely. Fluid lines should also be cleared of all debris.

Warning: Make sure that fluid flow has been shut off and pressure in the line released before attempting to install the meter in an existing system.

The flow meter must be installed with the flow indication arrow, etched on the exterior of the meter body, pointing in the correct direction of flow. The preferred mounting orientation is to have the meter installed in horizontal piping, with the pickup facing upward. However, the meter will function in any position.

The liquid that is to be measured must be free from any large particles that may obstruct rotation of the rotor. If particles are present, a mesh strainer should be installed upstream before operation of the flow meter. (See Table 1)

Table 1

New Model Number	Strainer Mesh
FTB-1301 & FTB-1311	140 x 140
FTB-1302 & FTB-1312	140 x 140
FTB-1303 & FTB-1313	140 x 140
FTB-1304 & FTB-1314	50 x 50
FTB-1305 & FTB-1315	50 x 50
FTB-1306 & FTB-1316	50 x 50
FTB-1307 & FTB-1317	50 x 50
FTB-1308 & FTB-1318	50 x 50

Note: Select appropriate strainer for your turbine model by your turbine part number.

The preferred plumbing setup is one containing a bypass line that allows meter inspection and repair without interrupting flow. If a bypass line is not utilized, it is important that all control valves be located downstream of the flow meter.

It is recommended that a minimum length, equal to ten (10) pipe diameters of straight pipe be installed on the upstream side and five (5) diameters on the downstream side of the flow meter. Otherwise meter accuracy may be affected. Piping should be the same size as the meter bore or the thread port size.

Do not locate the flow meter or the connection cable close to electric motors, transformers, sparking devices, high voltage lines or place connecting cable in conduit with wire furnishing power for such devices. These devices can induce false signals in the flow meter coil or cable, causing the meter to read inaccurately.

Operational Start Up:

The following practices should be observed when installing and starting the meter.

- 1) After meter installation, close the isolation valves, and open the bypass valve. Flow liquid through the bypass valve for sufficient time to eliminate any air or gas in the flow line.

Caution: Damage can be caused by striking an empty meter with a high velocity flow stream.

- 2) Open upstream isolating to eliminate hydraulic shock while charging the meter with the liquid. Open the valve to full open.
- 3) Open downstream isolating valve to permit meter to operate.
- 4) Close the bypass valve to a full closed position.
- 5) Adjust the downstream valve to provide the required flow rate through the meter.

NOTE: the downstream valve may be used as a control valve.

If problems arise with the flow meter, consult the Trouble Shooting Guide (Appendix A). If further problems arise, consult the factory. Turbine meter repair kits are also available. See appendix B & C.

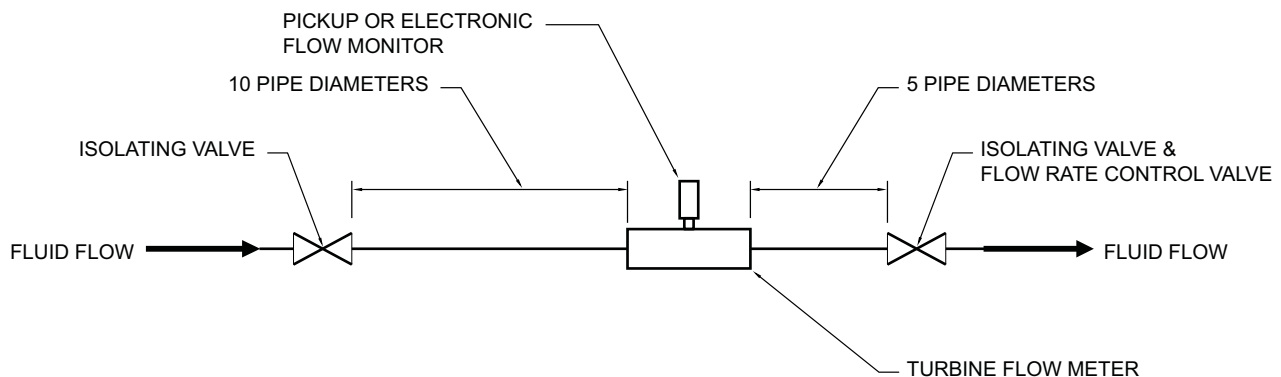
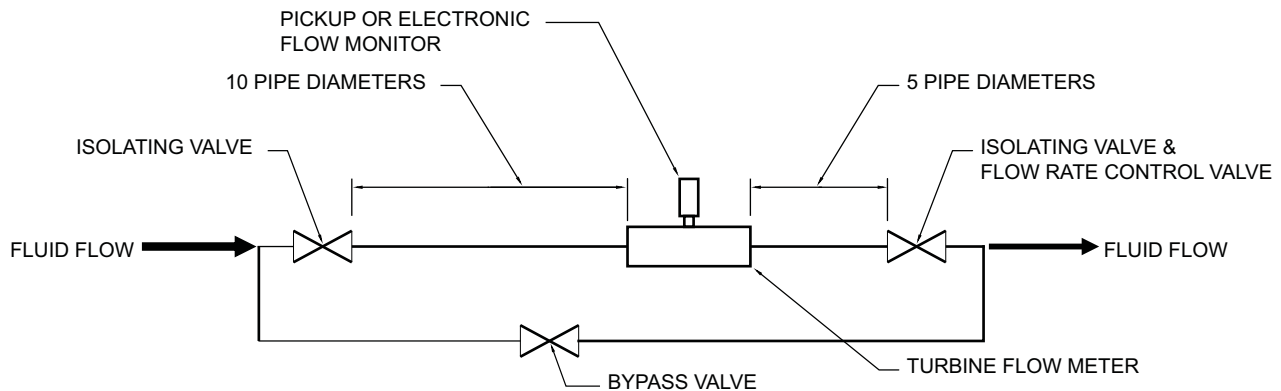

Trouble Shooting Guide:

Trouble	Possible Cause	Remedy
Meter indicates higher than actual flow rate	Cavitation	Increase back pressure
	Debris on rotor support	Remove debris
	Build up of foreign material on the meter bore	Clean meter
	Gas in liquid	Install gas eliminator ahead of meter
Meter indicates lower than actual flow rate	Debris on rotor	Clean meter and add filter
	Worn bearing	Clean meter, add filter and replace bearing
	Viscosity higher than calibrated	Recalibrate monitor (Appendix A)
Erratic system indication, meter alone works well (remote monitor application only)	Ground loop in shielding	Ground shield one place only. Look for internal electronic instrument ground. Reroute cables away from electrical noise.
Indicator shows flow when shut off	Mechanical vibration causes rotor to oscillate without turning	Isolate meter
No flow indication. Full or partial open position.	Fluid shock, full flow into dry meter or impact caused bearing separation or broken rotor shaft.	Rebuild meter with repair kit and recalibrate monitor. Move to location where meter is full on start-up or add downstream flow control valve.
Erratic indication at low flow, good indication at high flow.	Rotor has foreign material wrapped around it.	Clean meter and add filter.
No flow indication.	Faulty pickup.	Replace pickup.
System works perfect, except indicates lower flow over entire range.	Bypass flow, leak.	Repair bypass valves, or faulty solenoid valves.
Meter indicating high flow, upstream piping at meter smaller than meter bore.	Fluid jet impingement on rotor.	Change piping.
Opposite affects as above.	Viscosity lower than calibrated.	Change temperature, change fluid or recalibrate meter.

Repair Kit Information

Line Sizes 1/8" up to 2"

Flow meter size	Repair kit fits meter model #	Repair kit part number
1/8"	FTB-1301 & FTB-1311	FTB-131-RK
1/4"	FTB-1302 & FTB-1312	FTB-132-RK
3/8"	FTB-1303 & FTB-1313	FTB-133-RK
1/2"	FTB-1304 & FTB-1314	FTB-134-RK
5/8"	FTB-1305 & FTB-1315	FTB-135-RK
7/8"	FTB-1306 & FTB-1316	FTB-136-RK
1-1/2"	FTB-1307 & FTB-1317	FTB-137-RK
2"	FTB-1308 & FTB-1318	FTB-138-RK

Caution: Always reassemble rotor supports. Rotor and meter body are all marked with flow arrows, which must all point in the same direction.

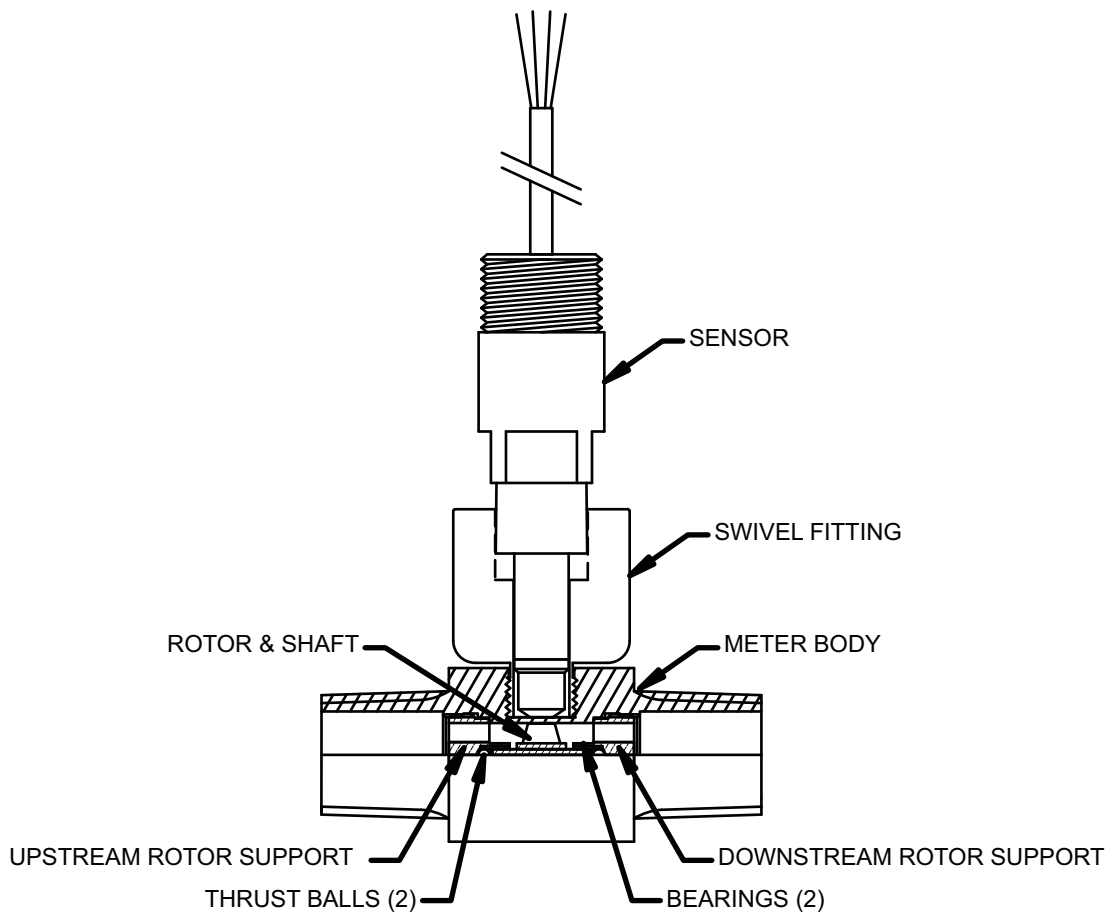

FTB-1301 to FTB-1308 Hall Effect Pickup

Installation and Technical Data Guide

Description:

The FTB-1301 - 1308 Hall Effect sensors are compatible with Positive Displacement gear flow meters and turbine flow meters. The sensor detects the rotation of the flow meter's gears and emits a frequency signal proportional to flow. The output signal is a square wave pulse which has a duty cycle of approximately 50%.

Signal outputs are protected with a self-resetting fuse. This fuse has a 50mA nominal trip point. When a trip occurs, turn off power to the sensor and remove output load to reset fuse.

Installation:

- Ensure that the flowmeter sensor cavity is free of debris prior to installing pickup
- Swivel fitting is required for sensor mounting. **Note:** In order to receive correct swivel fitting with your sensor - you must specify meter part number when ordering
- 4 Steps to properly install sensor:
 - 1- Securely fasten swivel fitting on flow meter
 - 2- Turn set screws counter clockwise until they are not visible inside the swivel fitting
 - 3- Install sensor into swivel fitting until sensor bottoms out in the sensor hole
 - 4- Tighten set screws by turning clockwise

NOTE: DO NOT OVER TIGHTEN SET SCREWS OR SENSOR DAMAGE WILL OCCUR!

NOTE: WIRING SHOULD BE INSTALLED BY A QUALIFIED INSTRUMENTATION TECHNICIAN

Wiring Color Code:

MAG-PB	Wire Color
NC	Green
Output	White
Ground	Black
Supply	Red

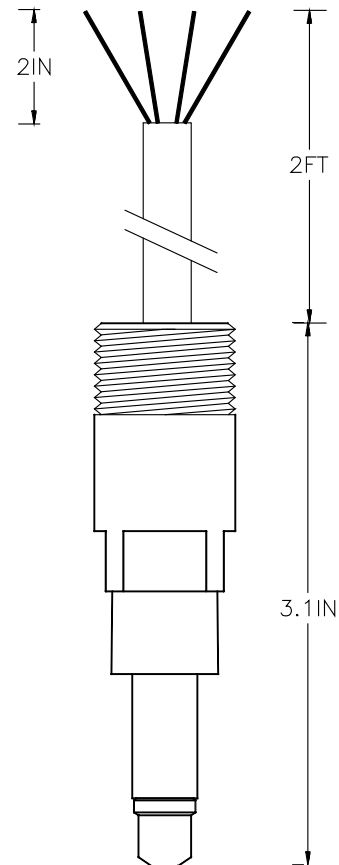

FTB-1301 to FTB-1308 Hall Effect Pickup

Installation and Technical Data Guide

Technical Data:

Supply Voltage:	+10 to 28 Volt DC
Supply Current:	8 mA @ 12 VDC, 12mA @ 24 VDC
Duty Signal:	50% ± 15%
Minimum Signal:	0.5 Hz
Frequency Output:	Flow dependent, up to 2,000 Hz
Driving Capacity:	50 mA Max resistive load
Output Impedance:	~ 40 Ohm - analog switch and self-resetting fuse
Temperature Range:	-40° F to 185° F (-40° C to 85° C)

MAG-PB Sourcing Output Circuit

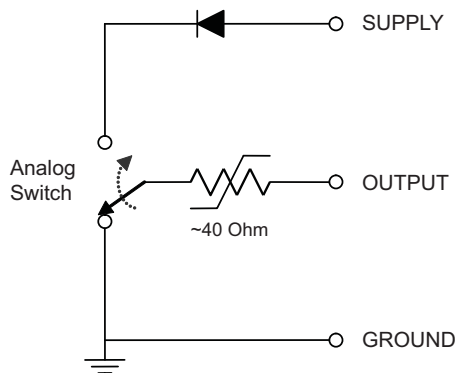

- Signal output square wave :
 $V_{high} = \text{Supply} - 1V$ @ no output load
 $V_{low} = 0.1V$
- Max sourced output voltage: Supply -0.5V
- Max current sourcing capabilities: 50mA

FTB-1311 to FTB-1318 Analog Output Pickup

Installation and Technical Data Guide

Description:

The FTB-1311-1318 are microprocessor based, meter mounted, analog output sensors. Each unit has a sensor, amplifier and converter module built into an Ex housing. The transmitter is designed to handle frequencies up to 5,000 Hz. The operational frequency range is user defined via four BCD rotary switches, where the high flow rate in frequency is set to 20 mA and the output signal is automatically scaled. End connection is a 3-pin male connector.

NOTE: This is a 3 wire hookup and is not suitable for a 2 wire installation.

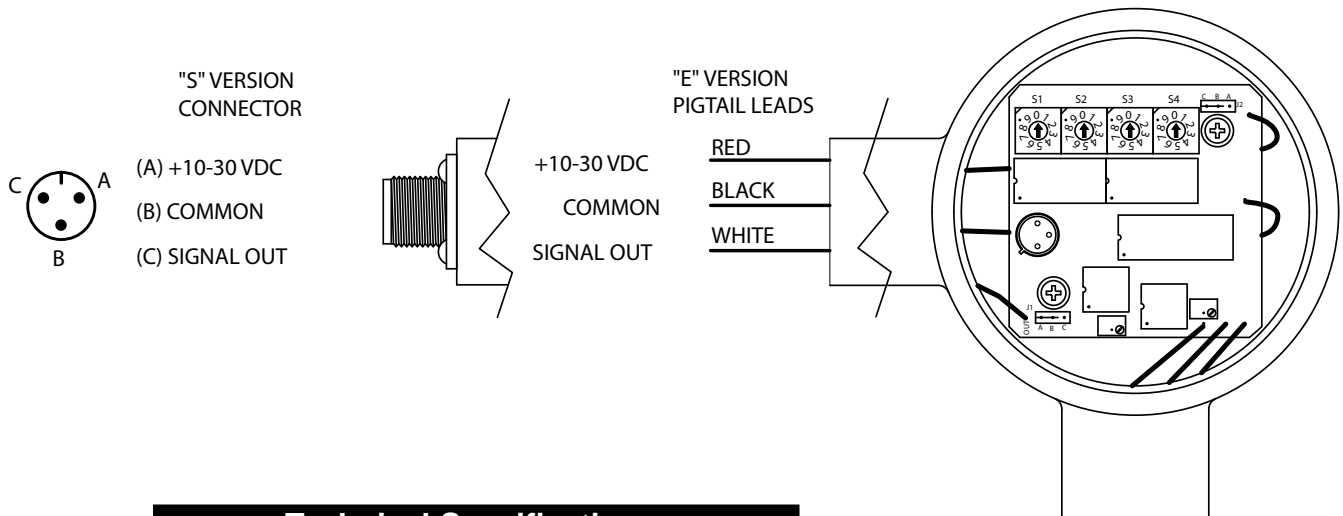

Technical Specifications:

Supply Voltage:	10-30 VDC
Supply Current:	60 mA max
Signal Output:	4-20mA or
Maximum Load Impedance ($V_{cc}/0.02$):	275 ohm (for mA out)
Temperature Range:	0-185° F

Jumper Settings:

J1	AB: Analog Output BC: Frequency Output
J2	AB: Housing Ground
CB:	Signal ground
Response Time:	1/F + 25 msec
Frequency Input:	5 KHz max
Diagnostics:	A glowing LED indicates the unit is working. The LED will blink to show an active frequency.

Scaling Analog Output:

On the front panel there are four rotary switches which are adjustable with a small screwdriver. It is not necessary to power the unit down to change the settings. The switches are read from left to right in order of decreasing value as shown in the figure to the right.

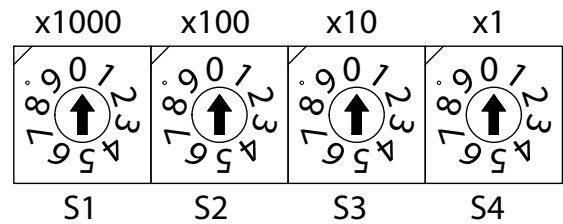

If the maximum frequency is known at which the resulting output should be 20mA, set the switches to this frequency. The output will automatically scale itself. If the maximum frequency is not known, the correct switch settings can be determined in 2 ways.

The following equation can be used to determine what the switch setting should be for any particular meter and flow rate.

$$\text{Switch Setting} = \frac{\text{K Factor} * \text{Max Flow Rate}}{60}$$

Where: K Factor is the flow meter scaling factor in pulses / volume (found on calibration sheet)

Max. Flow Rate is the flow rate at which the analog output should be at it's max.

Note: K-Factor and Max flow rate **MUST** have same units, ie: gallon/GPM, liter/LPM

60 is the scaling factor when max. flow rate is in volume/minute. Use 3600 for volume/hour

Ex: K Factor = 89,100 pulses/gallon (for a FTB-1301), Max flow rate = 0.2 GPM

$$\text{Switch Setting} = \frac{89,100 * 0.2}{60} = 297$$

If the numerical flow rate is not known, the unit can be calibrated in systems with the following:

- 1) Adjust system flow to the rate at which analog output should read 20 mA.
- 2) Set scaling switches to a value known to be above the maximum frequency (ex. 9, 49, 799, 2999) if unsure, use 4999
- 3) If S1 is 0, go to step 4. Decrease S1 until output shows 20 mA. Then increase its setting by one unless value is 4, in which case value should remain 4. If the switch value is 0 and the output is below 20 mA, leave switch at 0 and go to next switch.
- 4) If S2 is 0, go to step 5. Decrease S2 until output shows 20 mA. Then increase its setting by one unless value is 9, in which case value should remain 9. If the switch value is 0 and the output is below 20 mA, leave switch at 0 and go to next switch.
- 5) If S3 is 0, go to step 6. Decrease S3 until output shows 20 mA. Then increase its setting by one unless value is 9, in which case value should remain 9. If the switch value is 0 and the output is below 20 mA, leave switch at 0 and go to next switch.
- 6) Decrease S4 until output shows 20 mA and leave setting. **DO NOT** increase this setting by one. The switches are now set at the frequency which will result in a 20 mA output.

When setting switches in step 1, try to use numbers ending in 9 for example: 9, 39, 299 and 2999. Any switch setting above 5000 Hz is read as 4999 Hz.

Example: Actual maximum input frequency is 538 Hz. Switches are set to 0999 Hz, a value known to be above actual maximum input frequency. The output shows 12.64 mA.

Starting with the switch of highest order, in this case S2 since S1 is 0, its value is decreased until the output shows 20 mA (**S2 shows 4**). The switch is then increased by 1 (**S2 is set to 5**). S3 is then decreased until the output shows 20 mA (**S3 shows 2**). The switch is then increased by 1 (**S3 is set to 3**). Finally, S4 is decreased until the output shows 20 mA and left as such (**S4 set at 8**) the switches are now set to 538 Hz, the frequency which will cause maximum output current / voltage.

WARRANTY/DISCLAIMER

OMEGA ENGINEERING, INC. warrants this unit to be free of defects in materials and workmanship for a period of **13 months** from date of purchase. OMEGA's WARRANTY adds an additional one (1) month grace period to the normal **one (1) year product warranty** to cover handling and shipping time. This ensures that OMEGA's customers receive maximum coverage on each product.

If the unit malfunctions, it must be returned to the factory for evaluation. OMEGA's Customer Service Department will issue an Authorized Return (AR) number immediately upon phone or written request. Upon examination by OMEGA, if the unit is found to be defective, it will be repaired or replaced at no charge. OMEGA's WARRANTY does not apply to defects resulting from any action of the purchaser, including but not limited to mishandling, improper interfacing, operation outside of design limits, improper repair, or unauthorized modification. This WARRANTY is VOID if the unit shows evidence of having been tampered with or shows evidence of having been damaged as a result of excessive corrosion; or current, heat, moisture or vibration; improper specification; misapplication; misuse or other operating conditions outside of OMEGA's control. Components in which wear is not warranted, include but are not limited to contact points, fuses, and triacs.

OMEGA is pleased to offer suggestions on the use of its various products. However, OMEGA neither assumes responsibility for any omissions or errors nor assumes liability for any damages that result from the use of its products in accordance with information provided by OMEGA, either verbal or written. OMEGA warrants only that the parts manufactured by the company will be as specified and free of defects. OMEGA MAKES NO OTHER WARRANTIES OR REPRESENTATIONS OF ANY KIND WHATSOEVER, EXPRESSED OR IMPLIED, EXCEPT THAT OF TITLE, AND ALL IMPLIED WARRANTIES INCLUDING ANY WARRANTY OF MERCHANTABILITY AND FITNESS FOR A PARTICULAR PURPOSE ARE HEREBY DISCLAIMED. LIMITATION OF LIABILITY: The remedies of purchaser set forth herein are exclusive, and the total liability of OMEGA with respect to this order, whether based on contract, warranty, negligence, indemnification, strict liability or otherwise, shall not exceed the purchase price of the component upon which liability is based. In no event shall OMEGA be liable for consequential, incidental or special damages.

CONDITIONS: Equipment sold by OMEGA is not intended to be used, nor shall it be used: (1) as a "Basic Component" under 10 CFR 21 (NRC), used in or with any nuclear installation or activity; or (2) in medical applications or used on humans. Should any Product(s) be used in or with any nuclear installation or activity, medical application, used on humans, or misused in any way, OMEGA assumes no responsibility as set forth in our basic WARRANTY/DISCLAIMER language, and, additionally, purchaser will indemnify OMEGA and hold OMEGA harmless from any liability or damage whatsoever arising out of the use of the Product(s) in such a manner.

RETURN REQUESTS/INQUIRIES

Direct all warranty and repair requests/inquiries to the OMEGA Customer Service Department. BEFORE RETURNING ANY PRODUCT(S) TO OMEGA, PURCHASER MUST OBTAIN AN AUTHORIZED RETURN (AR) NUMBER FROM OMEGA'S CUSTOMER SERVICE DEPARTMENT (IN ORDER TO AVOID PROCESSING DELAYS). The assigned AR number should then be marked on the outside of the return package and on any correspondence.

The purchaser is responsible for shipping charges, freight, insurance and proper packaging to prevent breakage in transit.

FOR **WARRANTY** RETURNS, please have the following information available BEFORE contacting OMEGA:

1. Purchase Order number under which the product was PURCHASED,
2. Model and serial number of the product under warranty, and
3. Repair instructions and/or specific problems relative to the product.

FOR **NON-WARRANTY** REPAIRS, consult OMEGA for current repair charges. Have the following information available BEFORE contacting OMEGA:

1. Purchase Order number to cover the COST of the repair,
2. Model and serial number of the product, and
3. Repair instructions and/or specific problems relative to the product.

OMEGA's policy is to make running changes, not model changes, whenever an improvement is possible. This affords our customers the latest in technology and engineering.

OMEGA is a registered trademark of OMEGA ENGINEERING, INC.

© Copyright 2007 OMEGA ENGINEERING, INC. All rights reserved. This document may not be copied, photocopied, reproduced, translated, or reduced to any electronic medium or machine-readable form, in whole or in part, without the prior written consent of OMEGA ENGINEERING, INC.

Where Do I Find Everything I Need for Process Measurement and Control? **OMEGA...Of Course!** *Shop online at omega.com*

TEMPERATURE

- ☑ Thermocouple, RTD & Thermistor Probes, Connectors, Panels & Assemblies
- ☑ Wire: Thermocouple, RTD & Thermistor
- ☑ Calibrators & Ice Point References
- ☑ Recorders, Controllers & Process Monitors
- ☑ Infrared Pyrometers

PRESSURE, STRAIN AND FORCE

- ☑ Transducers & Strain Gages
- ☑ Load Cells & Pressure Gages
- ☑ Displacement Transducers
- ☑ Instrumentation & Accessories

FLOW/LEVEL

- ☑ Rotameters, Gas Mass Flowmeters & Flow Computers
- ☑ Air Velocity Indicators
- ☑ Turbine/Paddlewheel Systems
- ☑ Totalizers & Batch Controllers

pH/CONDUCTIVITY

- ☑ pH Electrodes, Testers & Accessories
- ☑ Benchtop/Laboratory Meters
- ☑ Controllers, Calibrators, Simulators & Pumps
- ☑ Industrial pH & Conductivity Equipment

DATA ACQUISITION

- ☑ Data Acquisition & Engineering Software
- ☑ Communications-Based Acquisition Systems
- ☑ Plug-in Cards for Apple, IBM & Compatibles
- ☑ Datalogging Systems
- ☑ Recorders, Printers & Plotters

HEATERS

- ☑ Heating Cable
- ☑ Cartridge & Strip Heaters
- ☑ Immersion & Band Heaters
- ☑ Flexible Heaters
- ☑ Laboratory Heaters

ENVIRONMENTAL MONITORING AND CONTROL

- ☑ Metering & Control Instrumentation
- ☑ Refractometers
- ☑ Pumps & Tubing
- ☑ Air, Soil & Water Monitors
- ☑ Industrial Water & Wastewater Treatment
- ☑ pH, Conductivity & Dissolved Oxygen Instruments